



X-Series 1992-2004 Mustang GT/Cobra/Mach 1 EFI Single Nozzle System Part # 22-82001

INSTALLATION INSTRUCTIONS

INTRODUCTION

Thank you for purchasing the highest quality nitrous system on the market. Nitrous Outlet strives to offer the best product with the best price and customer service available. Nitrous Outlet has trained professionals on staff to help with any technical questions you may have before and after your installation. You can contact Nitrous Outlet at 1-866-648-7637 or sales@nitrousoutlet.com. All Nitrous Outlet systems are carefully designed to work on specific applications. We suggest contacting the tech department to learn what modifications, if any, are needed for this kit to work properly on your application. It is the purchaser's responsibility to follow all installation instruction guidelines and safety procedures supplied with the product. It is up to the customer to determine the compatibility of the product with the application the purchaser intends to install the product on. Nitrous Outlet assumes no responsibility or liability for damages incurred by these products manufactured or sold by Nitrous Outlet. Nitrous Outlet neither recommends nor condones the use of products manufactured or sold by Nitrous Outlet on vehicles, which may be driven on public roads or highways, and assumes no responsibility for damages incurred by such use. Nitrous Outlet accepts no responsibilities of knowing your state laws, and recommends that all products should be used for off road use only. These instructions will guide you through the installation of your Nitrous Outlet nitrous system. For the best results please follow the directions in order and step by step. This way you can insure you have a safe and properly installed system. Use red loc-tite or Teflon paste on all pipe thread connections. Do NOT use any type of sealer on the AN fittings (Flare, hose, and bottle connections) AN Fittings are designed to use the tapered seat to seal. NEVER USE TEFLON TAPE. If you use loc-tite you will need to heat the connector to loosen. Before starting your installation, disconnect the negative battery cable. See your owner's manual for information if needed.



Your system should come with everything you see here, the fuel feed/adaptor fitting may vary for vehicle specific systems. You will have everything you need to install a nitrous system on your vehicle; main feed line, fuel adapter fitting, nitrous and fuel lines, solenoids and brackets, electrical fittings and wire, relay and harness, bottle brackets, wide open throttle switch, toggle switch for system arm, nozzle and nozzle adapter, jetting for up to 200HP.

WWW.NITROUSOUTLET.COM

IMPORTANT—All appropriate safety equipment (i.e., gloves, tools) must be used during the installation of this product(s). Nitro Dave's LLC accepts no responsibility for injuries resulting in the installation of any product(s).



X-Series 1992-2004 Mustang GT/Cobra/Mach 1 EFI Single Nozzle System Part # 22-82001

INSTALLATION INSTRUCTIONS

Bottle placement is critical to the performance of your nitrous system. It is important to mount your nitrous bottle properly in order to ensure that the siphon tube located in the nitrous bottle picks up liquid nitrous.

If mounting the bottle in lay-down position, the bottle valve must be towards the front of the vehicle with the label facing up.

If mounting the bottle vertically, the valve handle and label must face toward the front of the vehicle. This position will orientate the siphon tube at the back of the bottle where the liquid nitrous will be during acceleration.

If mounting the bottle sideways in the vehicle the valve handle and label must be angled around 45° toward the front of the vehicle. This position will orientate the siphon tube at the back of the bottle where the liquid nitrous will be during acceleration.



1. Insert the bottle nipple into the bottle nut and tighten on to the bottle valve. Fasten bottle brackets around the bottle. Use the illustration as a guide for proper bottle and bracket orientation.
2. Place the bottle, still in the brackets, in a mounting location that will provide easy access. Using the brackets as a pattern, mark and drill four 3/8" holes.
3. Remove the bottle from the brackets and bolt the brackets down using the supplied hardware.

NOTE: Before drilling check for fuel tank, lines, wiring, etc. Secure bracket using the four supplied 5/16 bolts.

MOUNTING THE NOZZLE

The location of the nozzle will determine the solenoid placement. This system will come with plenty of line to run from the solenoid to the nozzle. Be sure to mock everything up to get a good idea of where you will mount your solenoids. On a wet single nozzle system the recommended nozzle location will be mounted into the inlet tube 2-6" in front of the throttle body. On a single nozzle dry system the nozzle will be placed in the air box before the mass air meter. Certain custom applications will dictate other nozzle location.

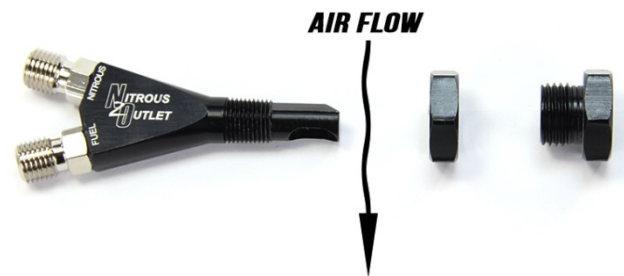

1. Determine the nozzle location. This area should be as flat as possible and free from obstruction. Mark and drill a 9/16" hole in the inlet tube.
2. Using a silicone RTV type sealant, apply a thin bead around the nozzle adapter surface. Insert adaptor from the inside of the inlet tube and snug the locking lug from the outside, the nozzle only fits in the adapter one way.
3. Thread the nozzle into the adaptor and position so that the discharge point is pointed towards the throttle body.

WWW.NITROUSOUTLET.COM

IMPORTANT—All appropriate safety equipment (i.e., gloves, tools) must be used during the installation of this product(s). Nitro Dave's LLC accepts no responsibility for injuries resulting in the installation of any product(s).



X-Series 1992-2004 Mustang GT/Cobra/Mach 1 EFI Single Nozzle System Part # 22-82001

INSTALLATION INSTRUCTIONS

- Using the supplied jet card choose the lowest horsepower jets available. Place jets into nozzle. It is always best to start small and work your way up to larger jets. Attach the black stainless line to the nozzle fitting marked "N2O" and the red line to the side marked "FUEL".

NOTE: Always check the jets for obstruction before using.

SOLENOID MOUNTING

The solenoids can be mounted vertically, horizontally or upside down.

- Nitrous Outlet nitrous solenoids are designed with 1/4 NPT inlets and 1/8NPT discharge ports. The nitrous solenoid has 2 1/8 NPT discharges, the side discharge is for a purge and the bottom location is the main nitrous discharge port. If you are not using a purge there is an included 1/8 plug to block off the purge port. Install all solenoid fitting using Teflon paste or loc-tite. NEVER USE TEFLON TAPE. The 1/4 x -4 fitting will go in the nitrous solenoid inlet. The 1/8 x-3 will go in the bottom discharge. One 1/8 x -3 will go in the fuel solenoid inlet, and the other 1/8 x -3 will go in the fuel side discharge port.
- The solenoid mounting brackets are designed to be universal. Start by mounting the bracket to the solenoids. Do not tighten, as you may have to flip the bracket over to align the solenoid for proper orientation. Try to locate an existing screw or bolt to mount the brackets. Remember you will need to locate the solenoids within reach of the nozzle lines. Tighten all mounting screws.
- Thread the black 3AN line onto the nitrous discharge and the red 3AN line to the fuel discharge port. The nitrous main feed line will attach to the nitrous solenoid inlet.

NOTE: Before attaching remove the tape and purge the feed line to remove any debris from the line. You can do this by blowing compressed air into the line while having an assistant hold the other end away from the car and any bystanders. Immediately after purging attach the feed line to the nitrous solenoid and the bottle nipple.

FUEL SUPPLY

Always open the fuel tank to relieve pressure from your fuel system first.

There are several ways to tap into the factory fuel supply. If your system is vehicle specific it will come with the correct fuel adapter fitting you will use to tap into the fuel rail.

Remove the fuel pressure sensor and place the fuel rail adapter in between the fuel rail and sensor with the fitting facing outward. Using the supplied hardware you can bolt the assembly back together.

NOTE: Care should be taken to confirm that the port you have selected is a fuel fitting, as there are several test ports in the engine bay.



ELECTRICAL

WWW.NITROUSOUTLET.COM

IMPORTANT—All appropriate safety equipment (i.e., gloves, tools) must be used during the installation of this product(s). Nitro Dave's LLC accepts no responsibility for injuries resulting in the installation of any product(s).



X-Series 1992-2004 Mustang GT/Cobra/Mach 1 EFI Single Nozzle System Part # 22-82001

INSTALLATION INSTRUCTIONS

Mount the toggle switch in the desired location in the cab. Using the blue wire provided, connect the switch to a switched 12-volt source. Connect a ground wire to the ground terminal on the toggle switch. Assemble the WOT switch to the supplied bracket using the 4-40 screws and nuts. Be careful to not over tighten as you can crack the WOT switch. The mounting bracket can bend to place the switch in the proper location. The activation arm is long enough to twist, bend, or cut to aid in installation. Run a wire from the remaining terminal to one side of the WOT switch. Wire the other side of the WOT switch to the red wire on the relay. Connect the supplied red wire to a 12-volt constant source and the black wire on the relay. Attach one wire from each solenoid to the green wire on the relay. Run the remaining wires to ground. Attach the white wire on the relay to ground. Reconnect the battery cable. At this point the system is ready for testing. Make sure Nitrous bottle is off and there is no pressure on the main feed line. With the key in the on position turn the toggle switch to the "on" position and push the WOT; you should hear the solenoids click. If no sound is heard or only one of the solenoids is clicking, check all connections and the wiring schematic for proper connection.

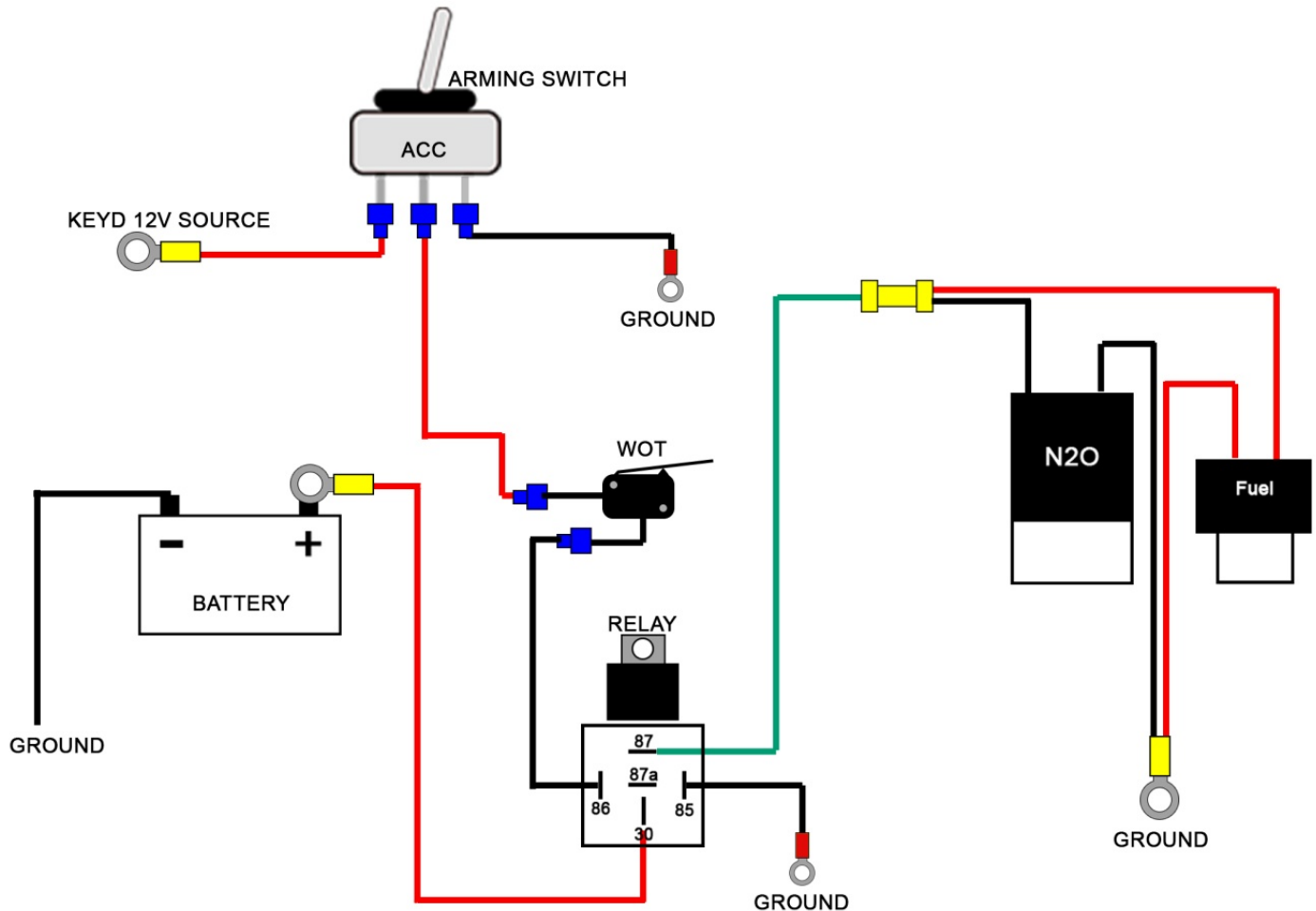



**X-Series 1992-2004 Mustang GT/Cobra/Mach 1
EFI Single Nozzle System
Part # 22-82001**

INSTALLATION INSTRUCTIONS

ROUTING THE MAIN FEED LINE

NOTE: Place a piece of tape over the end of the line before routing to prevent debris from entering the line.

The 16' 4AN nitrous feed line may be routed to the engine either through the passenger compartment or underneath the vehicle.

If routing the main feed line under the vehicle route the line as to avoid kinks, possible abrasion points or exhaust components. Drill a ¼" hole in a suitable area near the bottle valve. Starting at the bottle (do not attach line to nipple) route the line to the engine bay. Following the factory fuel line is usually the best route. Make sure to keep a safe distance from any moving parts, suspension components, and hot engine parts. Make sure to secure the line where possible. Avoid any electrical connections as sparks can destroy the lining and cause a nitrous leak. If routing the main feed line inside of the vehicle, route the main feed line from the back of the vehicle to the front exiting through the firewall into the engine bay, avoiding kinks, possible abrasion points, or electrical components.

CONCLUSION

With all components mounted, feed line and electrical connections completed, connect the feed line to the bottle and fully open the valve. Carefully check all connections for leaks and retighten fittings as needed. When there are no leaks detected start the engine and check for fuel leaks. After a complete inspection and verification that there are no leaks or shorts, it is time to SPRAY IT!