

Nitrous Outlet Stand Alone Do-It-Yourself (DIY) Remote Bottle Opener Wiring Harness Installation Instructions

PART NUMBER: 12-11500-RBO



The Nitrous Outlet Remote Bottle Opener, Stand Alone Pro Wiring Harness provides the perfect solution to simplifying the wiring process associated with remote bottle opener installations.

This harness comes complete with color coded wiring diagrams, step by step installation instructions, two way momentary rocker switch, Deutsch connector, harness grommet, ring terminal, heat shrink, expandable sleeving, 10 amp resetting circuit breaker, and 40/60 amp relays.

Table of Contents

Installation Instructions	2-8
Deutsch Connector Assembly	9
Deutsch Quick Disconnect Assembly	10
Wiring Diagram	11
Detailed Pinout Sheet	13

NITROUS OUTLET

IMPORTANT: All appropriate safety equipment (gloves, tools etc.) must be used during the installation of this product(s).

Nitro Dave's LLC accepts NO responsibility for injuries or damages resulting during and/or from the installation of any product(s). Nitrous oxide is for off-road use only.

WWW.NITROUSOUTLET.COM/INSTALLATION-GUIDES



Stand Alone DIY Remote Bottle Opener Wiring Harness

PART NUMBERS: 12-11500-RBO

INSTALLATION INSTRUCTIONS

This Nitrous Outlet DIY Wiring Harness is designed to simplify the wiring process associated with nitrous system bottle opener installs. If you need assistance with this wiring harness, call our Tech Help Line at (254) 848-4300.

Tools Needed for Installation:

- Drill
- 27/32" Hole Saw
- Small file
- Center Punch
- Marker
- Hot Knife
- Heat Gun
- Wire Crimping Tool

Additional Materials Needed for Installation:

- Electrical Tape

These are the basic tools required for installation of this harness. Your vehicle may require additional tools.



Relay Installation

- Once your remote bottle opener is installed, open the hood and disconnect the battery by removing the cables from the negative and positive terminals.

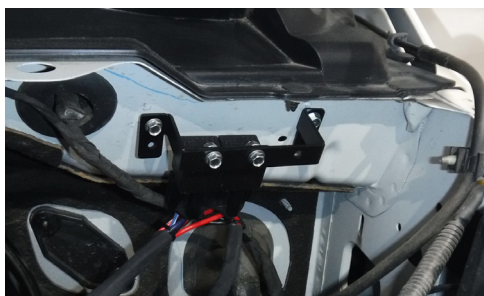

- This harness is designed for the relay to mount under the hood, close to the battery for positive and negative connections.



Routing the Harness

- Route the 10ga red and black wires from the relay to the battery. Make certain when installing the harness it is free from any extreme heat sources or moving parts that can damage the harness.



- Install the provided inline 10 amp circuit breaker with fuse holder to the red power source wire. Strip a small section off the end of the wire, crimp into the provided connector, and heat shrink the connection. Do not connect to the battery at this time.

IMPORTANT: All appropriate safety equipment (gloves, tools etc.) must be used during the installation of this product(s).

Nitro Dave's LLC accepts NO responsibility for injuries or damages resulting during and/or from the installation of any product(s). Nitrous oxide is for off-road use only.

WWW.NITROUSOUTLET.COM/INSTALLATION-GUIDES



Stand Alone DIY Remote Bottle Opener Wiring Harness

PART NUMBERS: 12-11500-RBO

INSTALLATION INSTRUCTIONS



Routing the Harness

The Harness is separated into 2 main leads traveling from the relay. These leads are labeled to their specific destinations.

Interior - Switch panel - 4 wire lead



Nitrous Bottle Location - Bottle opener - 2 wire lead



- Route the individual wires in each section to its connection point and secure them in place.

****NOTE - Do not cut any length of harness wiring at this time.**



- In the event that the harness needs to route through a drilled hole in the firewall use the supplied grommet to protect the wires from being damaged.

****NOTE - The grommet size included with your DIY harness requires a 9/16" panel hole.**



- The wires in each section of the harness will have several component leads that terminate in different destinations. Make sure when mounting a harness lead that you are properly securing it so it is avoiding any extreme heat or any moving parts that can damage the harness.

IMPORTANT: All appropriate safety equipment (gloves, tools etc.) must be used during the installation of this product(s).

Nitro Dave's LLC accepts NO responsibility for injuries or damages resulting during and/or from the installation of any product(s). Nitrous oxide is for off-road use only.

WWW.NITROUSOUTLET.COM/INSTALLATION-GUIDES



Stand Alone DIY Remote Bottle Opener Wiring Harness

PART NUMBERS: 12-11500-RB0

INSTALLATION INSTRUCTIONS

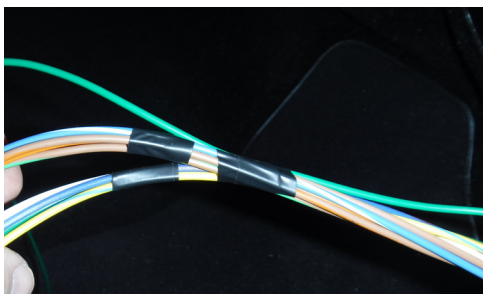

Disclaimer - The sleeving steps are generic instructions that apply to all harness installations. Wire colors will vary.

- Once the routing and securing the harness in its permanent location you will need to mark the point of branch off with a piece of electrical tape. 1-1 ½ times around the harness is all that is necessary.
- You do not have to fully remove the harness from the vehicle for sleeving. You can leave the relay mounted and remove the 2 main branches if desired. With the harness out of the vehicle, stretch it to full length.

- Start at the harness branches coming from the relay and every 16-18 inches, wrap electrical tape 1-1 ½ times around the harness.

IMPORTANT: All appropriate safety equipment (gloves, tools etc.) must be used during the installation of this product(s).

Nitro Dave's LLC accepts NO responsibility for injuries or damages resulting during and/or from the installation of any product(s). Nitrous oxide is for off-road use only.

WWW.NITROUSOUTLET.COM/INSTALLATION-GUIDES



Stand Alone DIY Remote Bottle Opener Wiring Harness

PART NUMBERS: 12-11500-RB0

INSTALLATION INSTRUCTIONS

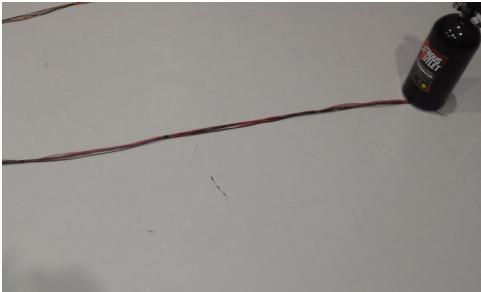

- Continue doing this for the length of the harness until you have reached the end of each lead.



- At the end of each lead, use a piece of tape to tightly group the wire ends so that the sleeving will easily slide over.

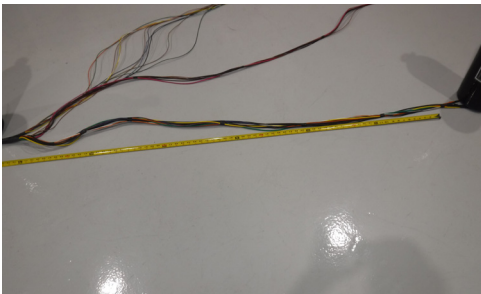

- To cut a specific length of sleeving, begin with one of the harness branches closest to the relay and measure up to the next branch. Make sure to add 6 to 8 inches to the measured length due to the fact that the sleeving will shorten as it expands over the harness.



- Cut all sections of sleeving with a hot knife. This will melt the fibers of the sleeving together so that it does not unravel while installing it on the harness.



- Feed the section of sleeving from the component end of the harness toward the relay. The best procedure for this is to feed all the sleeving onto the end of the harness. It will look like a compressed spring on the harness.

IMPORTANT: All appropriate safety equipment (gloves, tools etc.) must be used during the installation of this product(s).

Nitro Dave's LLC accepts NO responsibility for injuries or damages resulting during and/or from the installation of any product(s). Nitrous oxide is for off-road use only.

WWW.NITROUSOUTLET.COM/INSTALLATION-GUIDES



Stand Alone DIY Remote Bottle Opener Wiring Harness

PART NUMBERS: 12-11500-RB0

INSTALLATION INSTRUCTIONS

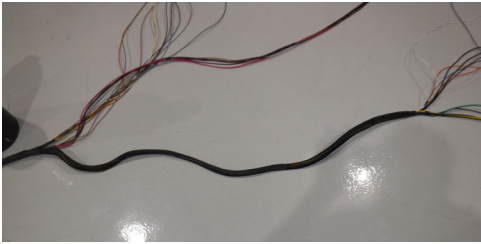

- Slide the sleeving to the measured section of the harness. Evenly distribute the sleeving along this section of the harness in both directions until it has fully expanded.

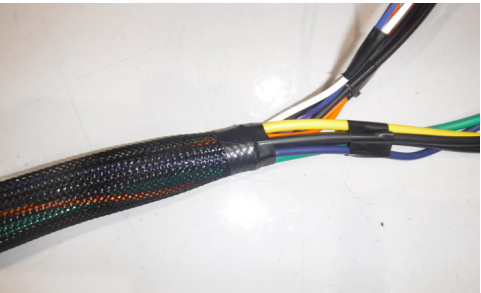

- Using electrical tape, tightly anchor each end using no more than 1 ½ rounds.



- Secure the taped ends of the sleeving to the harness with heat shrink. The heat shrink should cover the tape and a couple inches on both sides of the tape ring.

****NOTE - Do not hold the heat gun too close to the sleeving, this will cause it to melt and expose the wiring. Use extra precaution with the heat gun and being aware of wires and leads that can be damaged.**



- Repeat this process until you reach each component destination of the harness.



- Using heat shrink, cover the breakout or the branch off to ensure you have no exposed wires. This length will need to cover the end of the sleeving on the first section of wires to the start of the sleeving on the next section of the harness.

IMPORTANT: All appropriate safety equipment (gloves, tools etc.) must be used during the installation of this product(s).

Nitro Dave's LLC accepts NO responsibility for injuries or damages resulting during and/or from the installation of any product(s). Nitrous oxide is for off-road use only.

WWW.NITROUSOUTLET.COM/INSTALLATION-GUIDES



Stand Alone DIY Remote Bottle Opener Wiring Harness

PART NUMBERS: 12-11500-RB0

INSTALLATION INSTRUCTIONS



- After you have completed sleeving and heat shrink for each lead, reinstall the harness in its permanent mounting place.



Component Connection

- Determine how much wire you need from the harness lead to the designated component. Some components will have wire leads, such as the switch panel. Either the harness or component leads can be cut to length before the actual installation of the pins, connectors, or solder.

****NOTE - Connector assembly instructions are on pages 8 & 9 at the end of these instructions.**



- Using a 27/32" hole saw, drill a hole for the provided opener switch. Using a small file, cut a small notch (approximately 1/16") on the left side of the drilled hole for the alignment tab on the switch.



- A detailed color wire identification and connection chart and full color diagram have been provided with the harness to ensure proper connections. Follow these steps and chart to complete all component connections.

IMPORTANT: All appropriate safety equipment (gloves, tools etc.) must be used during the installation of this product(s).

Nitro Dave's LLC accepts NO responsibility for injuries or damages resulting during and/or from the installation of any product(s). Nitrous oxide is for off-road use only.

WWW.NITROUSOUTLET.COM/INSTALLATION-GUIDES



Stand Alone DIY Remote Bottle Opener Wiring Harness

PART NUMBERS: 12-11500-RBO

INSTALLATION INSTRUCTIONS

Final Checkover

Refer to the connectivity charts to ensure the proper pin location in each connector and the color and gauge size of each wire being connected.



- Double check all connections that you completed by giving a slight tug on both ends of the connection after the heat shrink is complete or the pins and connectors have been installed. The goal on installing the harness is to complete this process with a clean and secure attachment of all wiring connections, making sure they are not subject to damage due to heat or moving parts.



- Connect the orange 12ga wire from the 10 amp circuit breaker with fuse holder to the positive battery terminal or positive voltage supply.



- Connect the black 10ga wire leading out of the relay to the negative battery terminal or a known good ground.



- Once the installation steps have been completed, test the harness for functionality. Press the Opener switch, the bottle should fully open and close.

CONCLUSION

You have finished the installation of the DIY harness.

IMPORTANT: All appropriate safety equipment (gloves, tools etc.) must be used during the installation of this product(s).

Nitro Dave's LLC accepts NO responsibility for injuries or damages resulting during and/or from the installation of any product(s). Nitrous oxide is for off-road use only.

WWW.NITROUSOUTLET.COM/INSTALLATION-GUIDES



Deutsch Connector Assembly Instructions

INSTALLATION INSTRUCTIONS

Deutsch Connector Assembly:

To assemble Deutsch terminal ends you can use a special crimper, or if done cautiously, this can be done with a pair of needle nose pliers.

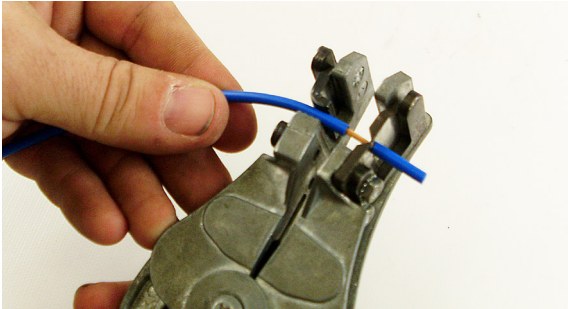

Step 1:

Strip the end of the wire you want to place the connector on about 3/8".

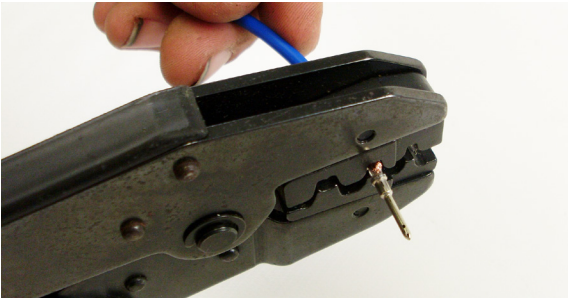

Step 2:

Using a crimp tool or needle nose pliers, crimp the connector down. First the smaller crimp and then the larger crimp, make sure the weather pack seal gets crimped with the larger side.



Step 3:

Once your sure you have a good crimp slide the pins into the connector housing being sure to match the wires correctly on each side. Push the pin in the housing until you feel a positive click and the wire cannot be pulled back out of the connector.

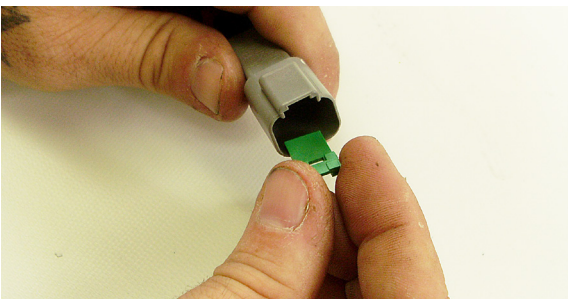

Step 4:

Install the provided pin retainer lock in the connector body. It simply snaps in to place.

IMPORTANT: All appropriate safety equipment (gloves, tools etc.) must be used during the installation of this product(s).

Nitro Dave's LLC accepts NO responsibility for injuries or damages resulting during and/or from the installation of any product(s). Nitrous oxide is for off-road use only.

WWW.NITROUSOUTLET.COM/INSTALLATION-GUIDES



Wire Quick Disconnect Assembly Instructions

INSTALLATION INSTRUCTIONS

Quick Disconnect Assembly:

To assemble terminal ends you can use a standard wire crimper/cutter, or if done cautiously, this can be done with a pair of needle nose pliers.



Step 1:

Slide a piece of heat shrink on to the connecting wire.

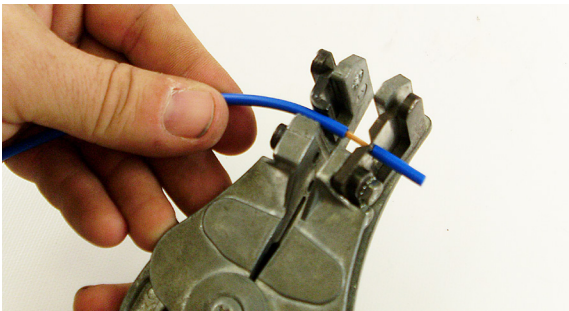

Step 2:

Strip about 3/8" off the end of the end of the connecting wire.



Step 3:

Using a crimp tool or needle nose pliers, crimp the connector on to the end of the connecting wire.



Step 4:

Once you are sure you have a good crimp slide the piece of heat shrink over the crimped end of the connector and seal it with a heat gun.

****NOTE - Do not hold the heat gun too close to the sleeving, this will cause it to melt and expose the wiring. Use extra precaution with the heat gun and being aware of wires and leads that can be damaged.**

IMPORTANT: All appropriate safety equipment (gloves, tools etc.) must be used during the installation of this product(s). Nitro Dave's LLC accepts NO responsibility for injuries or damages resulting during and/or from the installation of any product(s). Nitrous oxide is for off-road use only.

WWW.NITROUSOUTLET.COM/INSTALLATION-GUIDES

12-11500-RB0 DO-IT-YOURSELF REMOTE BOTTLE OPENER WIRING DIAGRAM

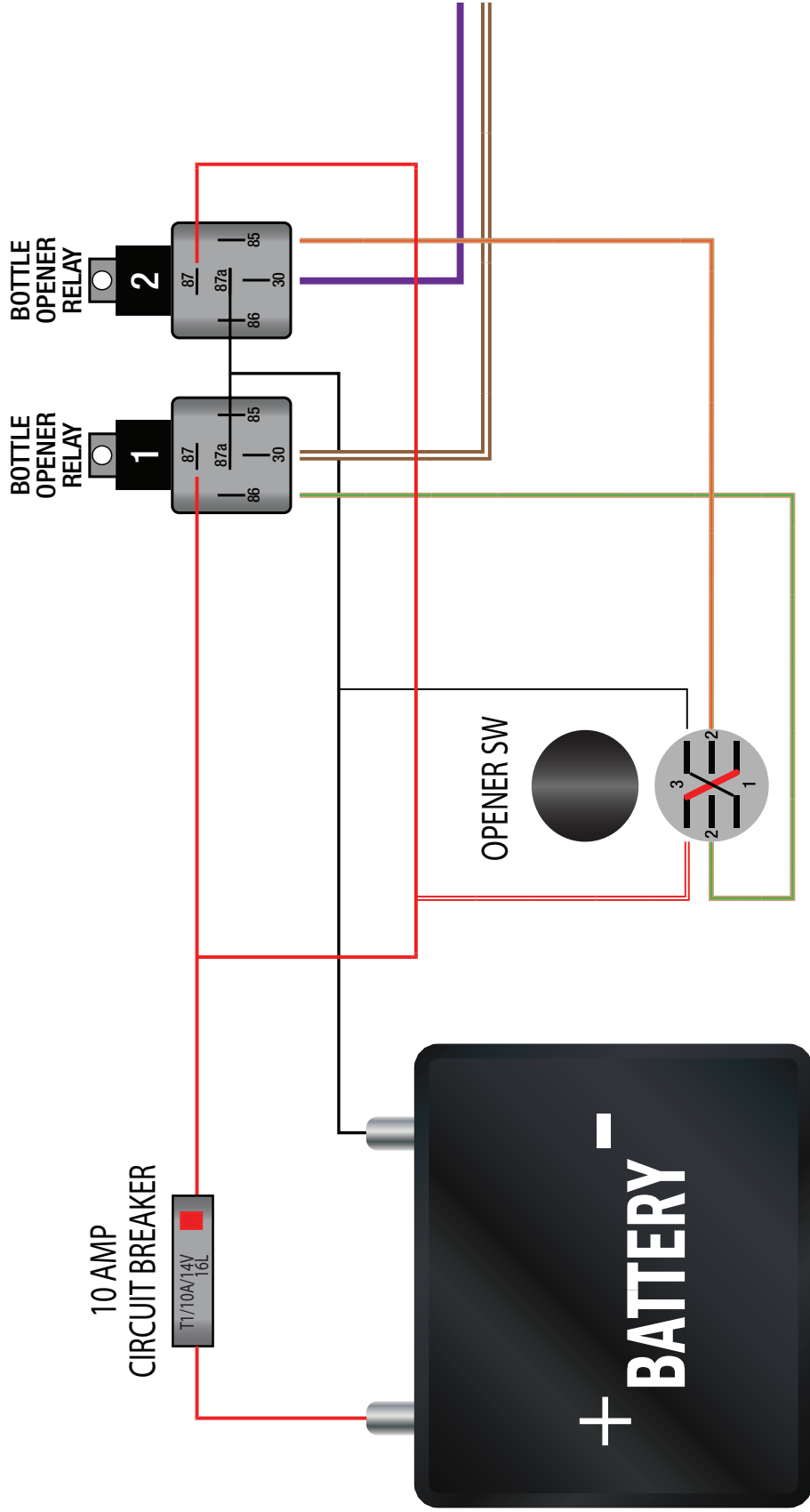

IMPORTANT: All appropriate safety equipment (gloves, tools etc.) must be used during the installation of this product(s). Nitro Dave's LLC accepts NO responsibility for injuries resulting in the installation of any product(s). Nitrous oxide is for off-road use only.

WWW.NITROUSOUTLET.COM/INSTALLATION-GUIDES

NITROUS OUTLET | 305 SOUTH 28TH STREET | WACO, TX 76710 | P: 254-848-4300 | WWW.NITROUSOUTLET.COM



12-11500-RB0 DO-IT-YOURSELF REMOTE BOTTLE OPENER WIRING DIAGRAM

BOTTLE OPENER

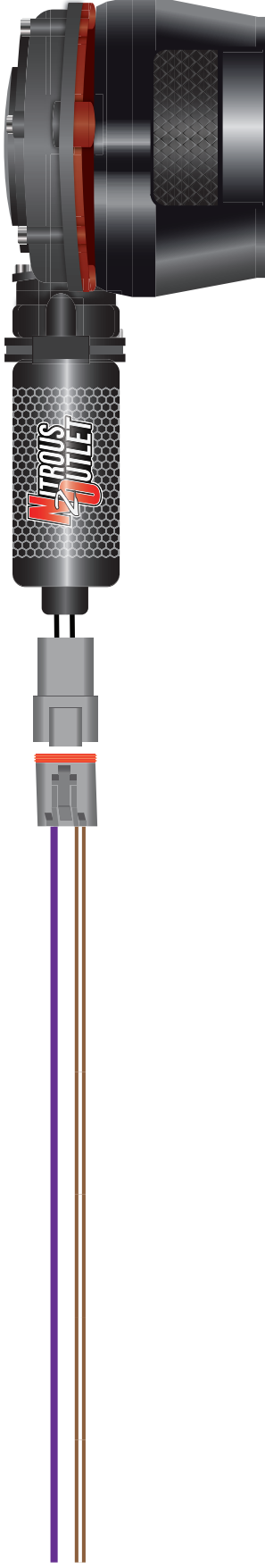

IMPORTANT: All appropriate safety equipment (gloves, tools etc.) must be used during the installation of this product(s). Nitro Dave's LLC accepts NO responsibility for injuries resulting in the installation of any product(s). Nitrous oxide is for off-road use only.

WWW.NITROUSOUTLET.COM/INSTALLATION-GUIDES

NITROUS OUTLET | 305 SOUTH 28TH STREET | WACO, TX 76710 | P: 254-848-4300 | WWW.NITROUSOUTLET.COM

©N20050422 12



12-11500-RB0 DO-IT-YOURSELF REMOTE BOTTLE OPENER WIRING DIAGRAM PINOUT SHEET



BOTTLE OPENER RELAYS		
BROWN/WHITE	12GA	PIN 30 RELAY 1 - BOTTLE OPENER
VIOLET	12GA	PIN 30 RELAY 2 - BOTTLE OPENER
RED	12GA	PIN 87 RELAY 1&2 - BATTERY POSITIVE
BLACK	12GA	PIN 87a,85,86,87a - BATTERY GROUND
TAN/GREEN	16GA	PIN 85 RELAY 1 - SWITCH PANEL
TAN/ORANGE	16GA	PIN 86 RELAY 2 - SWITCH PANEL
BATTERY		
RED	12GA	PIN 87 RELAY1&2 - BATTERY POSITIVE
BLACK	12GA	PIN 87a,85,86,87a - BATTERY GROUND
SWITCH PANEL/SWITCH(S)		
RED/WHITE	16GA	SWITCH - JUMPER PIN 87
BLACK	16GA	SWITCH - JUMPER - BATTERY GROUND
TAN/GREEN	16GA	SWITCH - RELAY 1 PIN 85
TAN/ORANGE	16GA	SWITCH - RELAY 2 PIN 86
BOTTLE OPENER LOCATION		
BROWN/WHITE	12GA	BOTTLE OPENER - PIN 30 RELAY 1
VIOLET	12GA	BOTTLE OPENER - PIN 30 RELAY 2

IMPORTANT: All appropriate safety equipment (gloves, tools etc.) must be used during the installation of this product(s). Nitro Dave's LLC accepts NO responsibility for injuries resulting in the installation of any product(s). Nitrous oxide is for off-road use only.

WWW.NITROUSOUTLET.COM/INSTALLATION-GUIDES

NITROUS OUTLET | 305 SOUTH 28TH STREET | WACO, TX 76710 | P: 254-848-4300 | WWW.NITROUSOUTLET.COM