

NITROUS OUTLET SERIES



Cut Installation Time in Half with the X-Series Stage 1 Plug and Play Wiring Harness

PART NUMBER: 12-11000-S1

The X-Series Stage 1 Harness was designed to provide a quick and easy solution for the do-it-yourself enthusiast. This harness is user friendly and can be used by beginners and pros alike. The end result is a professional built harness that will simplify system installation saving you time and money. This basic harness provides everything needed to wire in a X-series nitrous system, purge kit and WOT Switch.

Table of Contents

Installation Instructions	2-4
Deutsch Connector Assembly	5
Complete Color Wiring Diagram	6-8
Wire Color Identification Chart	9
Detailed Pin Out Sheet	10



IMPORTANT: All appropriate safety equipment (gloves, tools etc.) must be used during the installation of this product(s).

Nitro Dave's LLC accepts NO responsibility for injuries or damages resulting during and/or from the installation of any product(s). Nitrous oxide is for off-road use only.

WWW.NITROUSOUTLET.COM/INSTALLATION-GUIDES



X-Series Plug and Play Wiring Harness - Stage 1

PART NUMBER: 12-11000-S1

INSTALLATION INSTRUCTIONS

This Nitrous Outlet Wiring Harness is designed specifically for the X-Series Systems. If you need any assistance during installation or if you have questions about this wiring harness, call our Tech Help Line at (254) 848-4300.



- Open the hood and disconnect the battery by removing the cables from the negative and positive terminals.

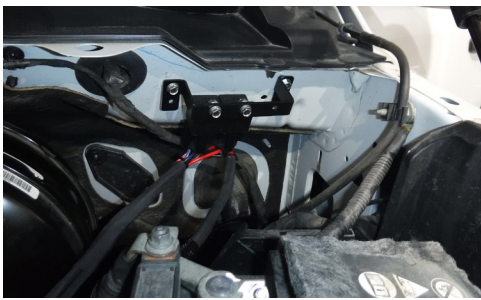

- This harness is designed for the relay center to mount under the hood, close to the battery for positive and negative connections. Applications that have the battery in the rear of the vehicle will require connection to the positive terminal and known ground terminal or stud under the hood.



- Route the switch panel wiring to the cabin of the vehicle. You may need to drill a 9/16" hole and use the provided grommet for this step.



IMPORTANT: All appropriate safety equipment (gloves, tools etc.) must be used during the installation of this product(s).

Nitro Dave's LLC accepts NO responsibility for injuries or damages resulting during and/or from the installation of any product(s). Nitrous oxide is for off-road use only.

WWW.NITROUSOUTLET.COM/INSTALLATION-GUIDES



X-Series Plug and Play Wiring Harness - Stage 1

PART NUMBER: 12-11000-S1

INSTALLATION INSTRUCTIONS

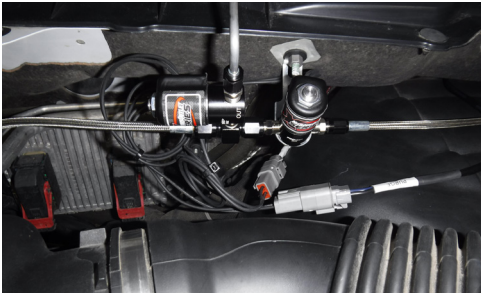

- Once your engine compartment components are installed, connect the harness to the system and purge solenoids. Each lead of the harness is labeled and terminated for the attaching component. Connector installation instructions are located on page 4 of these instructions. The solenoid wires can be installed into either side of the Deutsch connector. Make certain when installing the harness it is free from any extreme heat sources or moving parts that can damage the harness.



- If you have a system that includes a nitrous and fuel solenoid, connect the nitrous and fuel solenoid leads into the same connector. Make sure to have one wire from each solenoid in one side of the connector and the remaining wire from each solenoid in the other side of the connector. Connector installation instructions are located on page 4 of these instructions. Make certain when installing the harness it is free from any extreme heat sources or moving parts that can damage the harness.

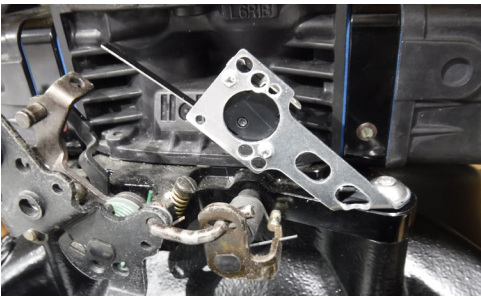

- Connect the WOT switch. For under-hood applications, the WOT switch should be installed on the carburetor or cable operated throttle body. For vehicles with a drive-by-wire throttle actuator, the WOT switch should be mounted under the gas pedal. Connect the provided WOT extension kit to the WOT wires on the harness, then route them into the interior of your vehicle. Each lead of the harness is labeled and terminated for the attaching component. The WOT switch wires can be installed on to either side of the switch. Make certain when installing the harness it is free from any extreme heat sources or moving parts that can damage the harness.



- Once all of your leads are plugged in to the under hood components, move to the interior and connect the switch panel leads at the switch panel. Follow the wire identification chart provided in the wiring schematics for the proper connection of your leads.



- Install the switch panel in your vehicle. The bolt holes in the switch panel are designed for #10 mounting hardware.

IMPORTANT: All appropriate safety equipment (gloves, tools etc.) must be used during the installation of this product(s).

Nitro Dave's LLC accepts NO responsibility for injuries or damages resulting during and/or from the installation of any product(s). Nitrous oxide is for off-road use only.

WWW.NITROUSOUTLET.COM/INSTALLATION-GUIDES



X-Series Plug and Play Wiring Harness - Stage 1

PART NUMBER: 12-11000-S1

INSTALLATION INSTRUCTIONS

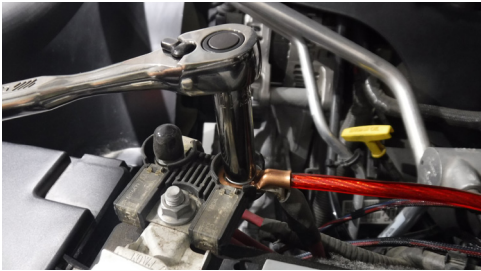

- Reconnect the battery cables, include the wiring harness ground and power wires.



TESTING & CONCLUSION

Once the installation steps have been completed, test the harness for functionality. Before connecting the nitrous feed line, flip the ARM switch to the on position. The red LED light should illuminate. Next, press the PURGE button. The purge solenoid should make a clicking sound. Lastly, when the WOT switch is actuated, the nitrous solenoid should make a clicking sound.

You have finished your installation.

IMPORTANT: All appropriate safety equipment (gloves, tools etc.) must be used during the installation of this product(s).

Nitro Dave's LLC accepts NO responsibility for injuries or damages resulting during and/or from the installation of any product(s). Nitrous oxide is for off-road use only.

WWW.NITROUSOUTLET.COM/INSTALLATION-GUIDES



X-Series Plug and Play Wiring Harness - Stage 1

PART NUMBER: 12-11000-S1

INSTALLATION INSTRUCTIONS

Deutsch Connector Assembly:

To assemble Deutsch terminal ends you can use a special crimper, or if done cautiously, this can be done with a pair of needle nose pliers.

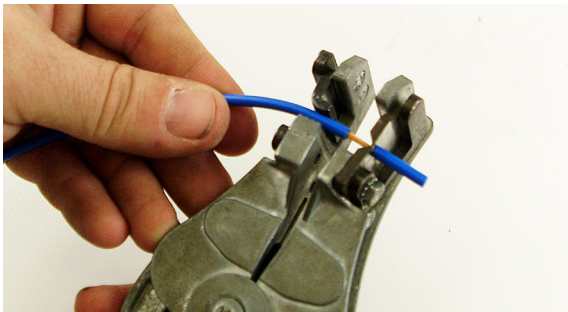

Step 1:

- Strip the end of the wire you want to place the connector on about 3/8".

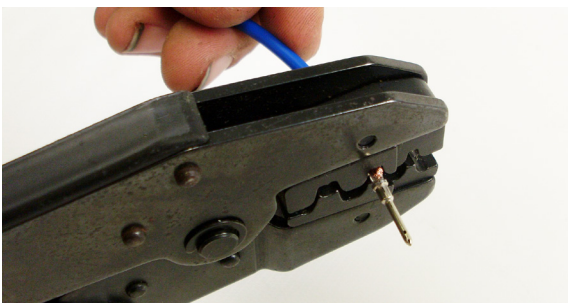

Step 2:

- Using a crimp tool or needle nose pliers, crimp the connector down. First the smaller crimp and then the larger crimp, make sure the weather pack seal gets crimped with the larger side.

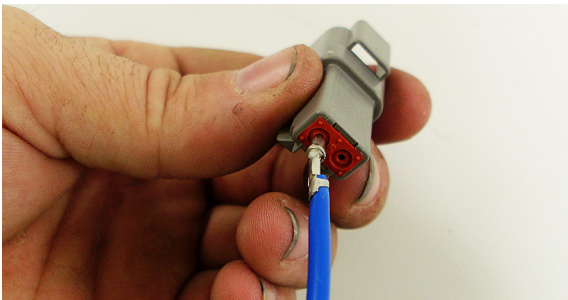

Step 3:

- Once your sure you have a good crimp slide the pins into the connector housing being sure to match the wires correctly on each side. Push the pin in the housing until you feel a positive click and the wire cannot be pulled back out of the connector.

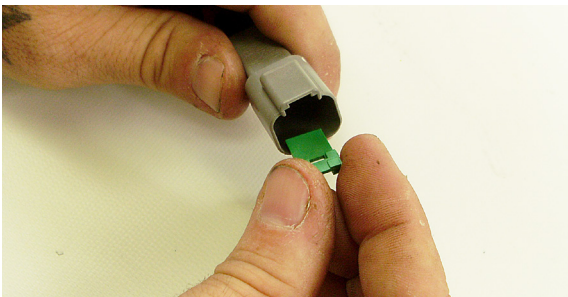

Step 4:

- Install the provided pin retainer lock in the connector body. It simply snaps in to place.

IMPORTANT: All appropriate safety equipment (gloves, tools etc.) must be used during the installation of this product(s).

Nitro Dave's LLC accepts NO responsibility for injuries or damages resulting during and/or from the installation of any product(s). Nitrous oxide is for off-road use only.

WWW.NITROUSOUTLET.COM/INSTALLATION-GUIDES



X-SERIES STAGE 1 WIRING HARNESS - 12-11000-S1

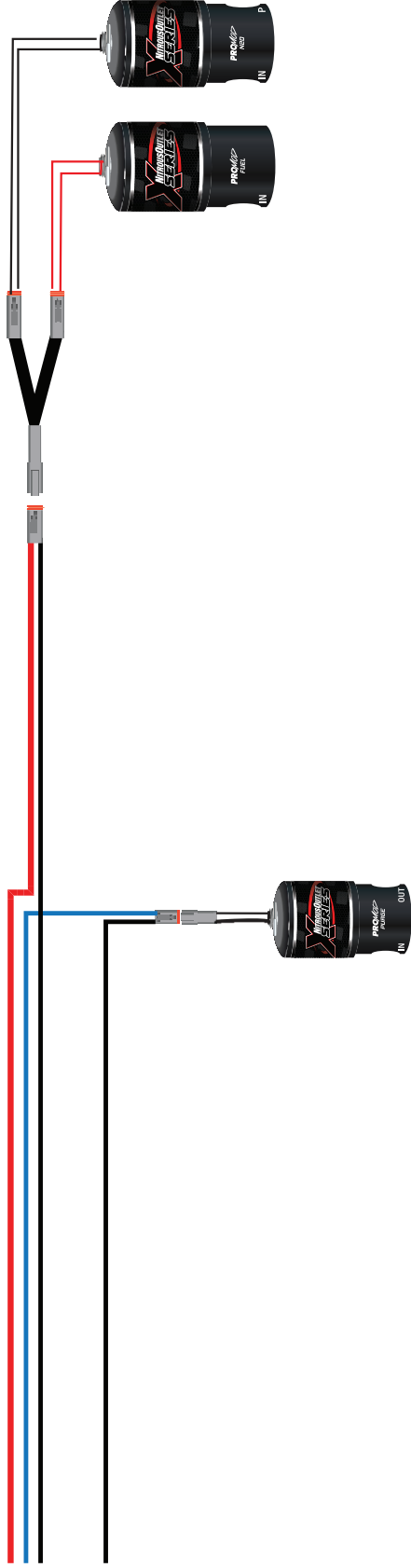

IMPORTANT: All appropriate safety equipment (gloves, tools etc.) must be used during the installation of this product(s). Nitro Dave's LLC accepts NO responsibility for injuries resulting in the installation of any product(s). Nitrous oxide is for off-road use only.

WWW.NITROUSOUTLET.COM/INSTALLATION-GUIDES

NITROUS OUTLET | 305 SOUTH 28TH STREET | WACO, TX 76710 | P: 254-848-4300 | WWW.NITROUSOUTLET.COM



X-SERIES STAGE 1 WIRING HARNESS - 12-11000-S1

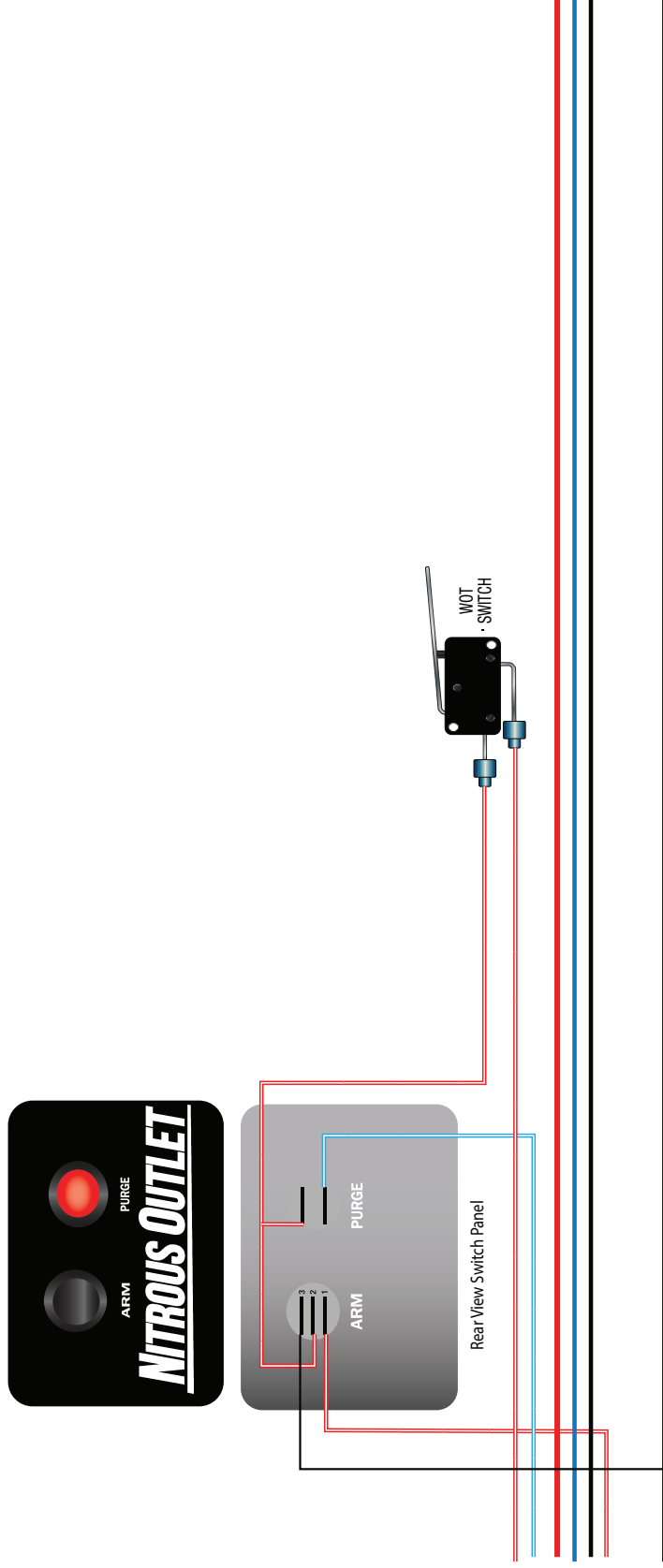

IMPORTANT: All appropriate safety equipment (gloves, tools etc.) must be used during the installation of this product(s). Nitro Dave's LLC accepts NO responsibility for injuries resulting in the installation of any product(s). Nitrous oxide is for off-road use only.

WWW.NITROUSOUTLET.COM/INSTALLATION-GUIDES

NITROUS OUTLET | 305 SOUTH 28TH STREET | WACO, TX 76710 | P: 254-848-4300 | WWW.NITROUSOUTLET.COM



X-SERIES STAGE 1 WIRING HARNESS - 12-11000-S1

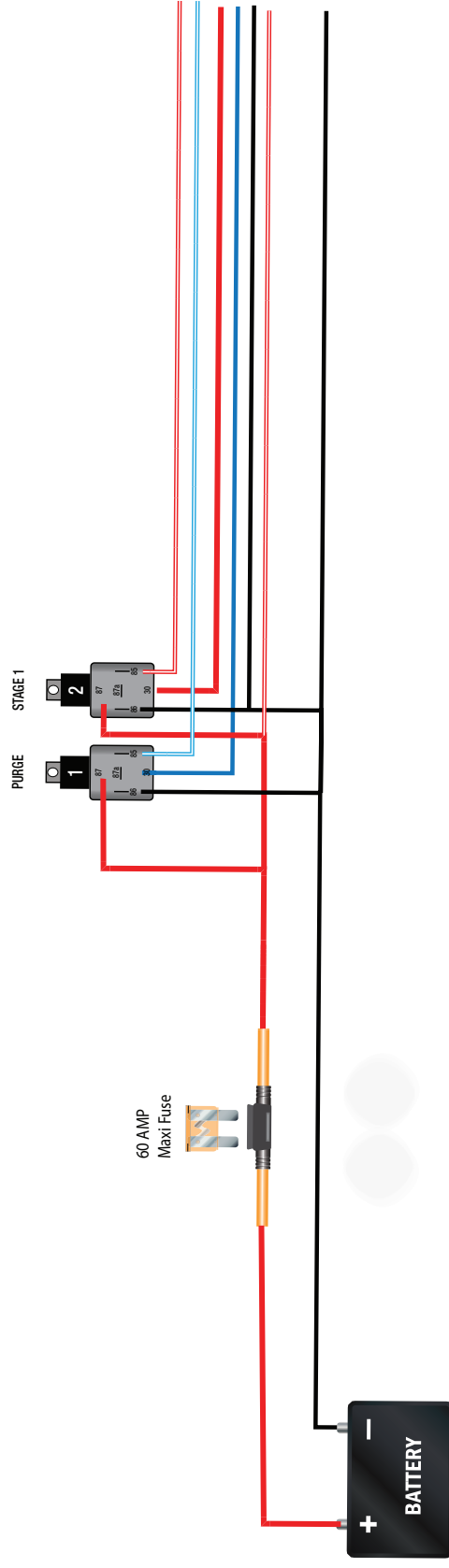

IMPORTANT: All appropriate safety equipment (gloves, tools etc.) must be used during the installation of this product(s). Nitro Dave's LLC accepts NO responsibility for injuries resulting in the installation of any product(s). Nitrous oxide is for off-road use only.

WWW.NITROUSOUTLET.COM/INSTALLATION-GUIDES

NITROUS OUTLET | 305 SOUTH 28TH STREET | WACO, TX 76710 | P: 254-848-4300 | WWW.NITROUSOUTLET.COM



X-SERIES STAGE 1 WIRING HARNESS - 12-11000-S1 WIRE COLOR IDENTIFICATION CHART

Power Source Battery



Battery Ground



12v Switched



Purge Power



Purge Relay from Switch



IMPORTANT: All appropriate safety equipment (gloves, tools etc.) must be used during the installation of this product(s). Nitro Dave's LLC accepts NO responsibility for injuries resulting in the installation of any product(s). Nitrous oxide is for off-road use only.

WWW.NITROUSOUTLET.COM/INSTALLATION-GUIDES

NITROUS OUTLET | 305 SOUTH 28TH STREET | WACO, TX 76710 | P: 254-848-4300 | WWW.NITROUSOUTLET.COM



X-SERIES STAGE 1 WIRING HARNESS - 12-11000-S1 PIN OUT SHEET

Relay Center	
Relay 1 Purge	
Red	10GA Pin 87 - Battery Positive
Black	10GA Pin 86 - Battery Negative
Lt Blue/White	16GA Pin 85 - Purge Button Switch Panel
Blue	12GA Pin 30 - Purge Solenoid
Red/White	14GA Pin 87 - Arm Switch Power
Relay 2 Stage 1	
Red	10GA Pin 87 - Batter Positive
Black	10gGA Pin 86 - Battery Negative
Red	12GA Pin 30 - N2O/Fuel Solenoid(s)
Red/White	14GA Pin 85 - WOT Switch
Switch Panel	
Red/White	14GA Arm Switch - Pin 87 Purge Relay Jumper
Red/White	14GA Arm Switch - WOT Switch Jmpr to Purge Button
Lt Blue/White	16GA Purge Button - Pin 85 Purge Relay
Black	16GA Arm Switch - Establish Interior Ground
WOT Switch	
Red/White	14GA WOT Switch - Arm Switch
Red/White	14GA WOT Switch - Pin 86 Stage 1 Relay
Stage 1 Solenoid(s)	
Red	12GA Stage 1 - Pin 30 Stage 1 Relay
Black	12GA Stage 1 - Battery Negative
Purge Solenoid	
Blue	12GA Purge Solenoid - Pin 30 Purge Relay
Black	12GA Purge Solenoid - Battery Negative

IMPORTANT: All appropriate safety equipment (gloves, tools etc.) must be used during the installation of this product(s). Nitro Dave's LLC accepts NO responsibility for injuries resulting in the installation of any product(s). Nitrous oxide is for off-road use only.

WWW.NITROUSOUTLET.COM/INSTALLATION-GUIDES