



USER MANUAL

SE-1 PORTABLE DIGITAL PIANO HOME BUNDLE

CONTENTS

Body Assembly Instructions	01-02
Important Items	03
Preface	03
Product Parameters	03
Packing List	03
Note	04
Power Connection	05
Volume Adjustment.....	05
Sockets On The Back of The Host	05
Single Pedal (Standard)	06
Three-pedal (Choosable)	06
Chord.....	07
Start / Stop Sync Start.....	07
Menu	07-08
Function Control	08
Reverb Level Setting	09
Chorus Level Setting	09
Dual Voice	09-10
Split Note.....	10
Percussion Setting	11
Memory Set of Voice / Rhythm	11
Data Selection	11
Demo Song	11
Tone / Rhythm	12
Intro / End.....	12
A / Fill 1 B / Fill 2.....	12
Metronome / Tempo.....	12
Record / Play.....	13
USB / Bluetooth.....	13
Headphone Jack	13
Voice List	14
Rhythm List	15
Demo Song List.....	16
Trouble Shooting	17

BODY ASSEMBLY INSTRUCTIONS

- To ensure the correct assembly of the Piano, read this manual carefully before assembly and place the manual where it is readily available for inspection.
- Please remove the main unit from the box and remove the protective cover and foam box. (Packaging and packaging materials must be kept for half a month).
- During assembly or handling, keep the device raised horizontally. Be careful of handling, be careful not to pinch your hands, or drop the device to your feet.
- Before you screw the screw to the final position, gently tighten the screw slightly more easily. Wait until the screw has entered about normal time and then increase the force. Do not use excessive force when screwing to the final position of the screw, which may damage the screw.
- After tightening the screws, place the device in a flat and stable place. Do not place it in a fluffy stall or on the ground. In this case, the pedals are easily swayed, resulting in skin lesions.
- Do not place the main body of the device directly on the floor. This will damage the bottom of the interface and bracket, and damage the host's bottom panel.
- Open the box, check the box items, such as the screw package is complete.
- Caution: Be sure to install the pedal to support the bolt. The black plum plastic part of the pedal support handle bolt should be unscrewed until it touches the ground (This largest bolt is to play the role of supporting the pedal force).

Accessories

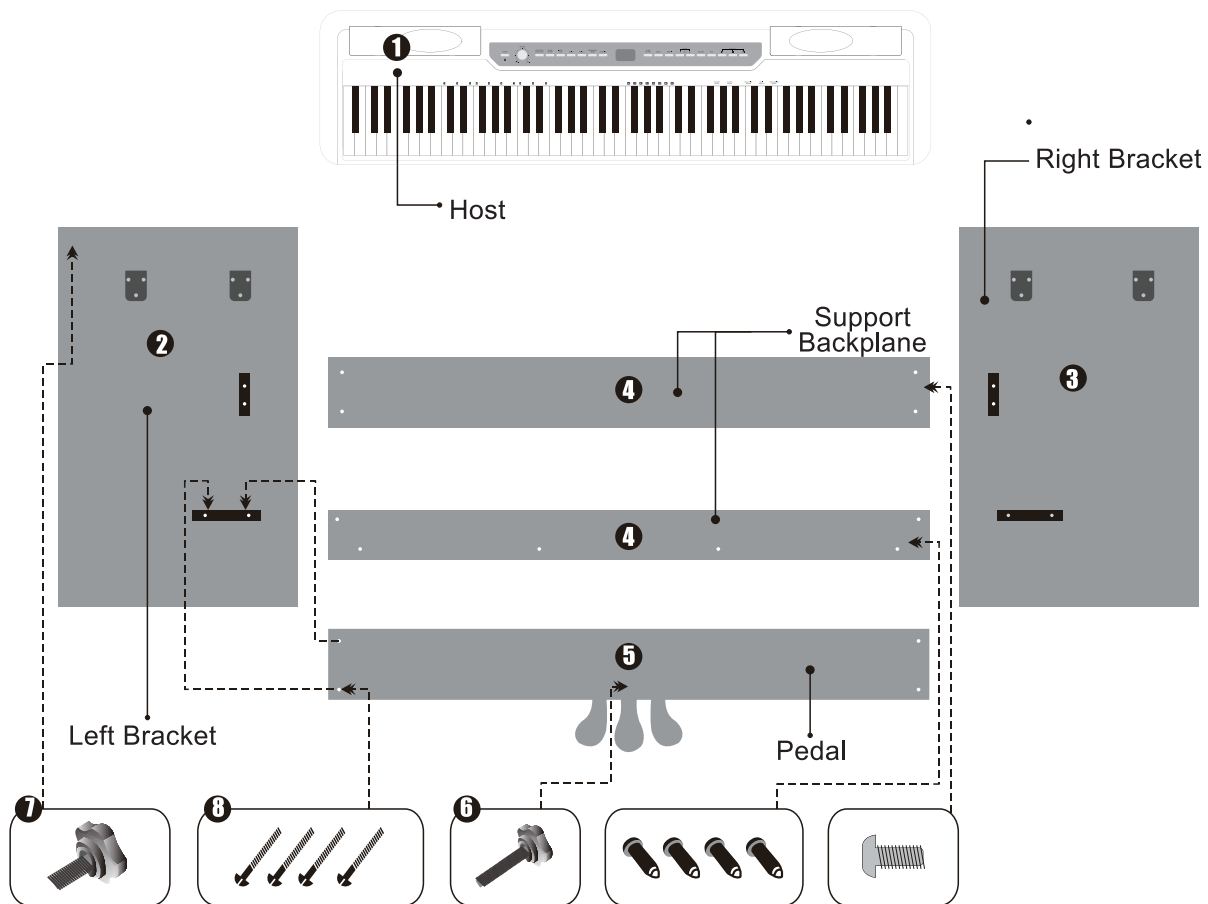

- | | |
|---------------------------|--|
| ① Host | ⑤ Pedal Bar |
| ② Left Bracket | ⑥ Plum-shaped Foot Support Screw:1 Pcs |
| ③ Right Bracket | ⑦ Plum-shaped Handle Screw:4 Pcs |
| ④ Support Backplane:2 Pcs | ⑧ Large Screws:4 Pcs |

Schematic diagram

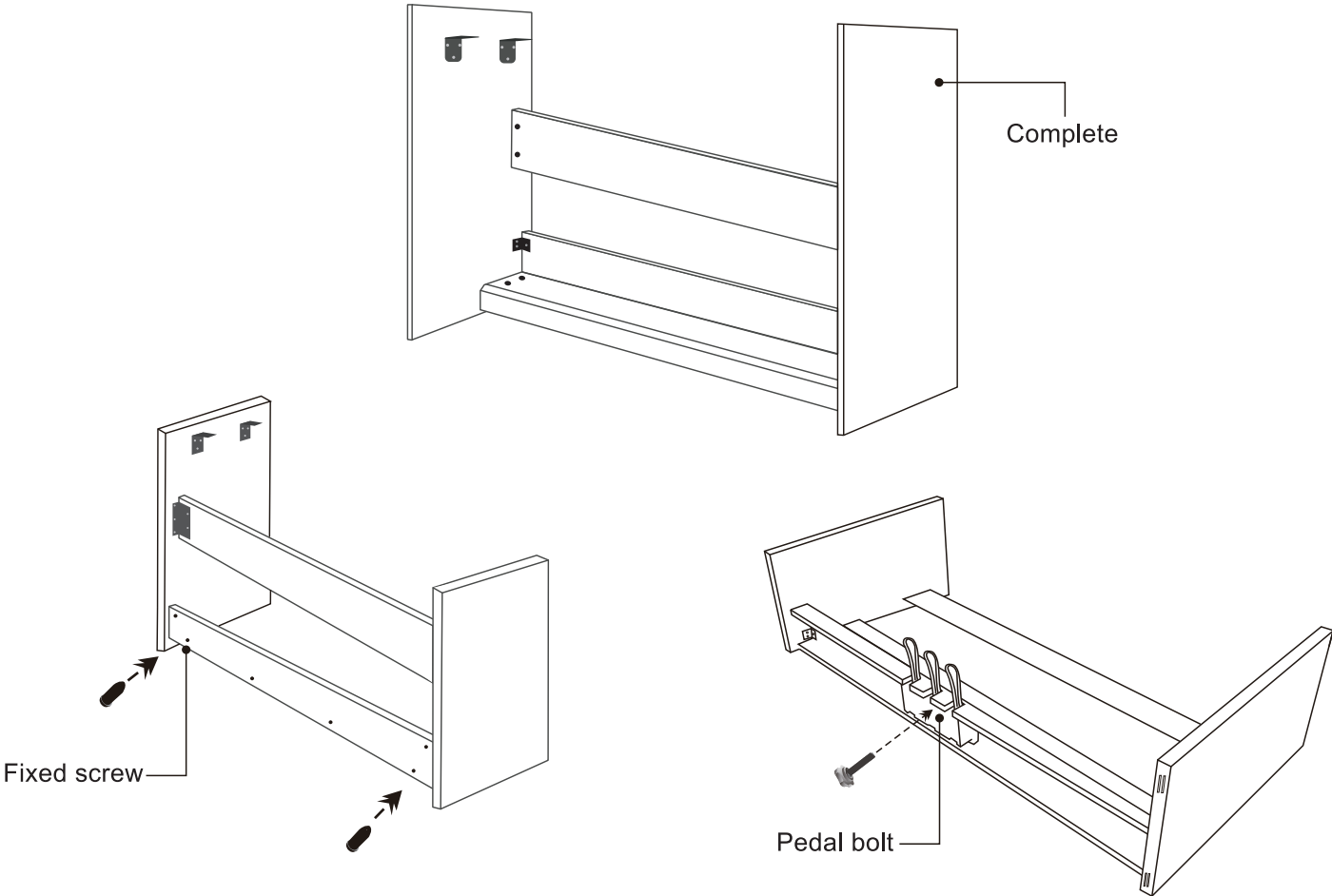

IMPORTANT ITEMS

Before using this product, please read the following important items.

- Before using the AC transformer to power the product, you must check whether the AC transformer has any damage.
- Please check the power code carefully to see if it is broken, bare or has other damage. Do not let children use seriously damaged AC transformer.
- Children under 3 years old are not allowed to use the product.
- AC transformer is not a toy.
- Before cleaning, you must remove the AC transformer.

PREFACE

Dear users:

Congratulations on your new SE-1 digital piano. It has advanced functions and good acoustic quality. With its help, you will start your musical journey. SE-1 electronic piano will bring you a new playing experience.

Please read the instructions carefully, so that you can make better use of it and play its performance.

Please keep it in a safe place, so that you can use it in the future.

PRODUCT PARAMETERS

Imported 88-key progressive keyboard with hammer touch

200 kinds of voice

100 kinds of rhythm

The maximum polyphony 128

Metronome

Key separation

Dual

Reverb

Automatic temperament stabilization system (tuning-free)

Split

USB/MIDI interface

Audio input/output

Stereo dual headphone jack

Record/Play

Connect to Apple products/ Android products/ Windows products

Transpose

Bluetooth

Touch curve

60 pieces of demonstration music

Output power 15W×2

Accessories: host, piano rack, three-pedal instructions, power adapter

Color: Black

Dimension: Length 1280mm x Width 330mm x Height 120mm

PACKING LIST

Dear users, please check whether the following items are complete after choosing.

HOST	SINGLE- PEDAL	INSTRUCTIONS
POWER ADAPTER	PIANO RACK / THREE-PEDAL (CHOOSABLE)	

Before using, please read the following items carefully, and keep the document in a safe place for future reference.

Warning

- When using the product, please comply with the following items to operate, so as to avoid serious injuries or death to users due to electric shock, short circuit, accident, fire or other dangers.
The items that users need to pay attention to:
- Do not open the electric piano or attempt to disassemble the components, and do not make any changes to the inside. This product does not have the parts that users can repair themselves.(If there is dysfunction, please contact qualified repairers for checking and maintenance.)
- Avoid exposing the electronic piano to rain, or using it near watery and humid places. Do not place containers with water on the electronic piano, because moisture may flow into the interior of the electronic piano.
- If the power cord or plug is worn or damaged, or if power is suddenly cut off during use, and you smell a strange odor or the electronic piano emits smoke, you should turn off the power immediately, remove the power plug, and ask a qualified repairer to check and maintain.
- Please ensure that the power supply voltage is 220 V \pm 10% AC, too high or too low voltage will cause damage to the piano.
- Before cleaning the electronic piano, you should turn off the power, remove the power plug. Do not operate with wet hands while the electricity is used. Do not wipe and clean the electronic piano with corrosive solvents.
- Regularly check the power switch and the power cord. When changing the fuse, be sure that you have removed the power plug, and ensure the use of the same fuse with the original specifications.

Warning

- Users should also obey the following rules during use, which can avoid the damage to the users or others, and the electronic piano or other external devices. The items that users need to pay attention to:
- Do not place the AC power cord near heat sources, such as a heater. Do not over-bend the power cord, put heavy objects on the power cord, place the power cord in a place where people go and wrap other things on the power cord to avoid damaging the power cord.
- When removing the power plug of the product, please take the plug itself, instead of pulling the cord.
Please remove the power plug if the electronic piano will not be used for a long time or when it thunders.
- Do not place this electronic piano in a dusty, vibrating, cold or hot environment (such as under the impact of direct sunlight, near the heating device or in the transportation tool in the sun) to avoid damaging the appearance of the electronic piano and the internal components.
- Before moving the electronic piano, you should remove the power cord and the wires connected to other equipment.
- When cleaning the electronic piano, please wipe it with a dry and soft cloth. Do not use paint thinner, organic solvents, detergents, or other chemicals with erosion effect to wipe the electronic piano, so as not to discolor the panel or keyboard.
- When the user connects the electronic piano to other devices, firstly, please turn off all the power switches. Before turning off the power switch, please set the volume to its minimum. When using the instrument, first set the electronic piano's volume to its minimum then gradually increase the volume until it fits.
- Do not place the electronic piano near other appliances, such as TV, radios, speakers, etc. Placing it near other appliances may cause interference between electrical appliances.
- Do not place the electronic piano in an unstable place so as not to cause the electric piano to fall down.
- Do not put heavy objects on the electronic piano, do not use excessive force to press the keys and toggle the control switch.
- In order to apply to the classroom, auditorium and other occasions, this electronic piano has been designed to have enough volume redundancy. The volume can be adjusted. You should adjust it to the proper value. If you use unreasonable excessive volume for a long time, this doesn't conform to the common sense of music, but also may cause hearing loss.
Avoid the electronic piano encounter a strong collision. Collisions may cause damage to the electronic piano and cause personal injury.

PREPARE BEFORE USE

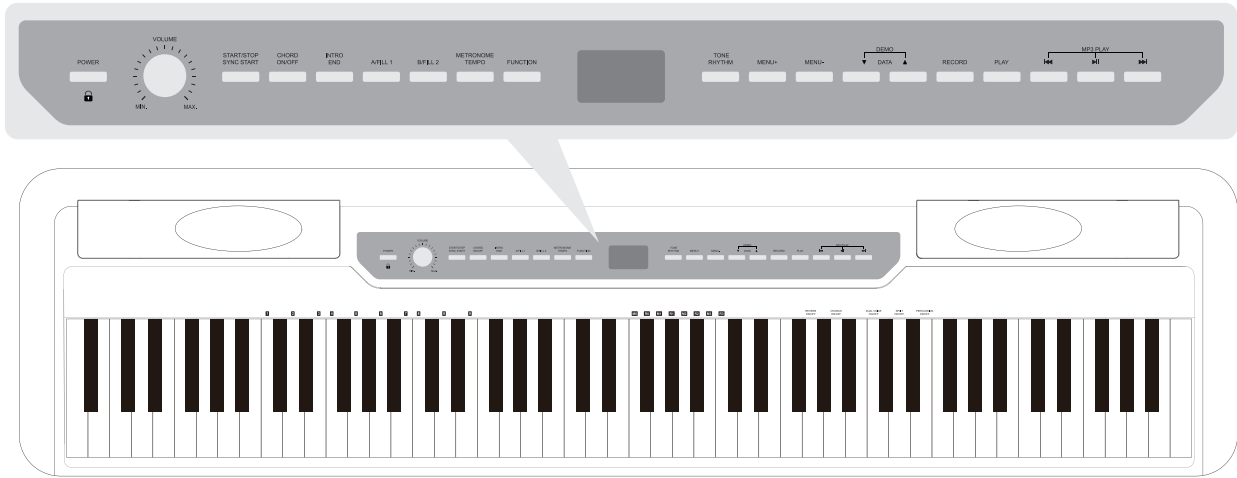

POWER CONNECTION

As shown in the picture, Connect the AC power adapter, if do not use it for a long time, please unplug the AC power plug from the socket.

1. Press [POWER] button to connect the power supply, the button light on, default voice is GrandPiano.
2. Long press [POWER] for 2 seconds to turn off the power.
3. Without any operation, it will turn off after 30 minutes.

VOLUME ADJUSTMENT

Adjust [VOLUME] on the control panel to set the volume.

Clockwise turns up, anticlockwise turns down.

Warning

When you don't use the digital piano or it thunders, please unplug the plug.

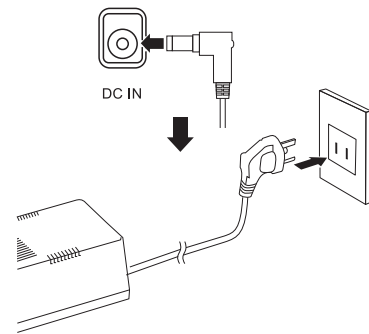
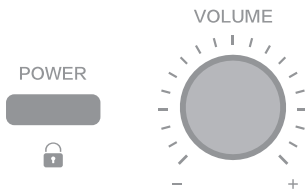

SOCKETS ON THE BACK OF THE HOST

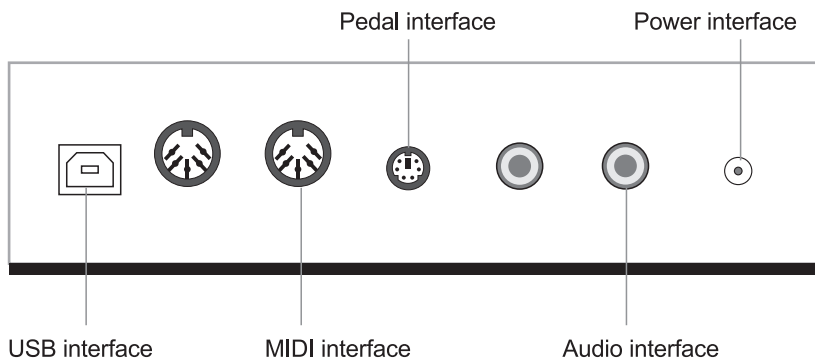

SINGLE PEDAL (STANDARD)

Connect standard single-pedal to PEDAL interface, press the pedal can extend the notes.

THREE-PEDAL (CHOOSABLE)

According to the traditional grand piano, the digital piano use the same damper pedal, sostenuto pedal and soft pedal as the traditional grand piano. press the pedal to turn on; Release the pedal to turn off.

Please connect the pedal wire to the pedal socket of the bottom of the host.

DAMPER PEDAL

(Right) After pressing the damper pedal, notes will be extended; Release the pedal to turn off.

Damper pedal illustration

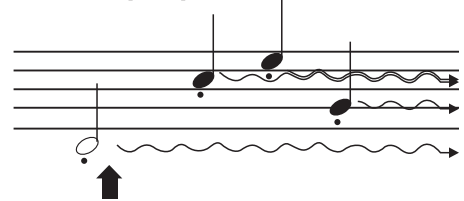

If you press the damper pedal there, the note and the note that you played before releasing the pedal will extend longer.

SOSTENUTO PEDAL

(Middle) Press and hold the note key while pressing the pedal, which can extend the pressed note (as if pressing the damper pedal) but the subsequent notes will not be extended.

Sostenuto pedal illustration

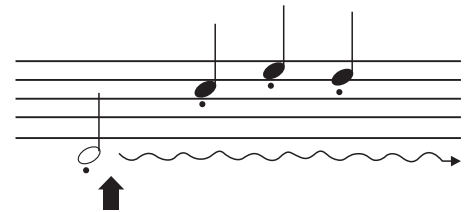

If you press and hold the note, while pressing the sostenuto pedal, this can extend the note until the pedal is released.

SOFT PEDAL

(Left) Press the soft pedal to down the volume of the note that you are playing, at this time, the voice changes. The notes played before pressing the pedal are not affected.



Before depressing the pedal, be sure that you have installed the pedal support screw and it is fully grounded.

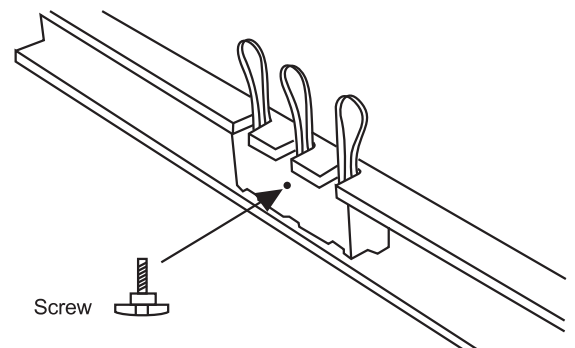

CHORD

1. Press [CHORD ON / OFF], indicator light on, turn on Automatic chords.
2. Press [CHORD ON / OFF] again ,indicator light off, turn off Automatic chords.

START / STOP SYNC START

1. Press [START/STOP, SYNC START] to turn on automatic accompaniment, start to play the selected accompaniment at present.
2. Press [START/STOP, SYNC START] for 2 seconds, indicator light shine, enter SYNC state.

■ How to use SYNC function

- a. Press [CHORD ON / OFF] to enter the state of chords, long press [START/STOP, SYNC START] to enter the state of SYNC, enter the standby mode of synchronous start.
- b. Play chord and the accompaniment starts automatically.
- c. Press [START/STOP, SYNC START] to cancel the state of SYNC.

START/STOP
SYNC START



CHORD
ON/OFF



MENU

1. Press [MENU+] to enter function menu, select to adjust or quit different functions circularly by pressing [MENU +], [MENU -].
2. In the function menu state, press [TONE / RHYTHM] to quit and get back to the original piano voice.

TONE
RHYTHM



MENU+



MENU-



Adjust the content	LCD Display	Adjust extent
Rhythm volume	Rhythm Volume	000-127
Transpose	Transpose	+/-12
Touch	Touch	001-003
Balance	Balance	000-127
Split note	Split note	045-096
Reverb level	Reverb level	001-008
Chorus level	Chorus level	001-008
Beat selection	Singnature	1/4,2/4,3/4,4/4,5/4,6/4,3/8,6/8,12/8

A. Rhythm volume adjustment

After selecting the rhythm volume, adjust the volume by "▼ DATA ▲". Adjust extent: 000-127.

B. Transpose

This can make notes to be moved up or down 12 semitones within an octave extent by pressing "▼ DATA ▲". Adjust extent: -12 to +12.

C. Touch

The digital piano has three touch curves. Adjust it by "▼ DATA ▲". Adjust extent: 001-003.

D. Balance

Adjust the dual voice by pressing "▼ DATA ▲" under the balance state. Adjust extent: 001-127.

E. Split note

Adjust the split note by pressing "▼ DATA ▲". Adjust extent: 045-096.

F. Reverb level

Adjust reverb level by pressing "▼ DATA ▲". Adjust extent: 001-008.

G. Chorus level

Select the chorus level by pressing "▼ DATA ▲". Adjust extent: 001-008.

H. Beat selection

Select the beat by pressing "▼ DATA ▲". There are nine kinds of beat can be selected: 1/4, 2/4, 3/4, 4/4, 5/4, 6/4, 3/8, 6/8, 12/8.

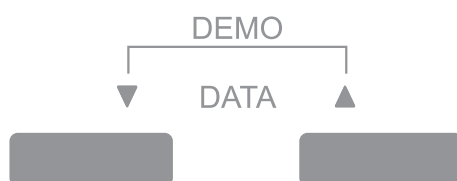

FUNCTION CONTROL

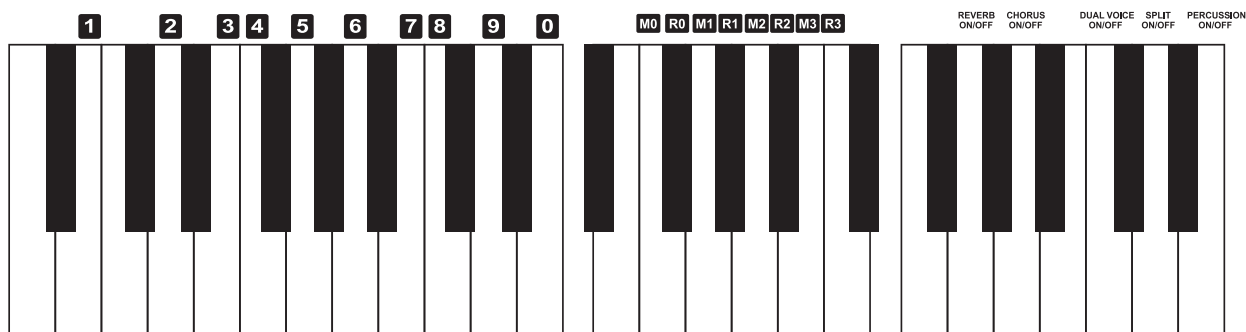

1. Press [FUNCTION], the indicator light shine. Press the corresponding key on the keyboard in 6 seconds to select the corresponding function.
2. Press [FUNCTION] again, the indicator off or without any operation in 6 seconds, the function state quits.

Attention:

The selected function will be displayed on the LCD screen . When entering the function setting state, the key is silent.

REVERB LEVEL SETTING

- Press [FUNCTION], the indicator light shine. Press corresponding [REVERB ON/OFF] on the keyboard in 6 seconds to activate the reverb level. The sound of playing a digital piano has a reverberation effect.
- Press [FUNCTION], the indicator light shine. Press corresponding [REVERB ON/OFF] on the keyboard again in 6 seconds to turn off reverb level.
- Select [Reverb level] from [MENU], and then adjust the reverb level 001-008(8 kinds) by " ▼DATA▲".

Attention: We can recognize whether the reverb function is off or not from the icon symbol on the screen.

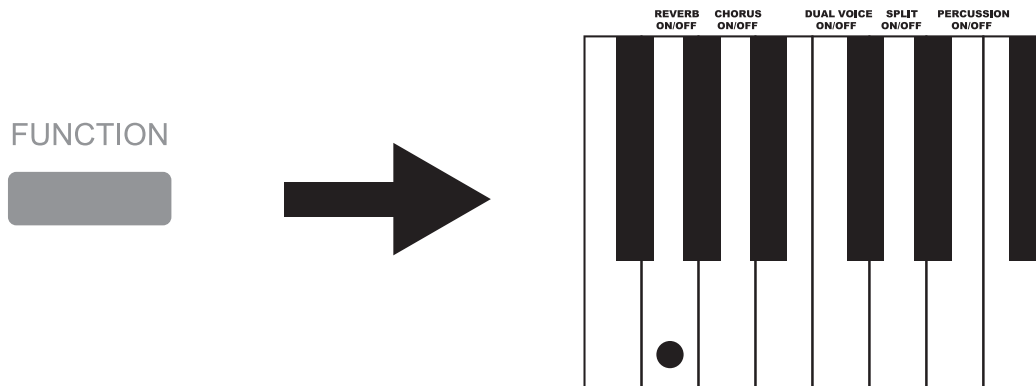

CHORUS LEVEL SETTING

- Press [FUNCTION], the indicator light shine. press corresponding [CHORUS ON/OFF] on the keyboard in 6 seconds to activate the chorus level;
- Press [FUNCTION], the indicator light shine. press corresponding [CHORUS ON/OFF] on the keyboard again in 6 seconds to turn off chorus level.
- Select [Chorus level] from [MENU], and then adjust the chorus level 001-008(8 kinds) by " ▼DATA▲".

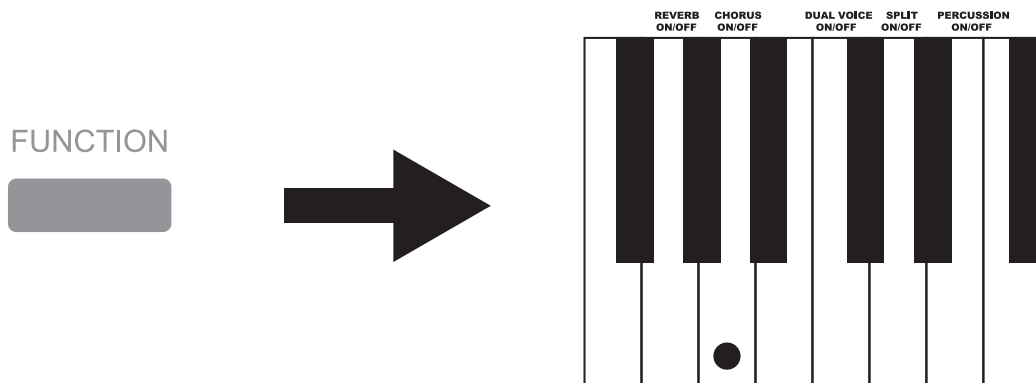

DUAL VOICE

- Press [FUNCTION], the indicator light shine. press corresponding [DUAL VOICE ON/OFF] on the keyboard in 6 seconds to activate Dual Voice;
- Press [FUNCTION], the indicator light shine. press corresponding [DUAL VOICE ON/OFF] on the keyboard again in 6 seconds to turn off Dual Voice.

■ How to use dual voice

- ① Enter voice mode and select an instrument as the main voice;
- ② Press [DUAL VOICE ON/OFF]
- ③ Select another instrument by [DATA] or number keys and then dual voice can be played.
- ④ Select [Balance] from [MENU], and then adjust the dual by [▼ DATA ▲].

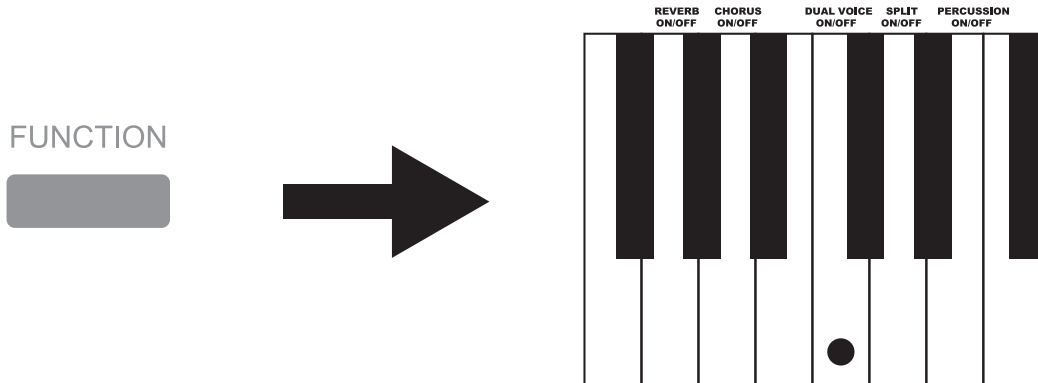

SPLIT NOTE

- a. Press [FUNCTION], the indicator light shine. press corresponding [SPLIT ON/OFF] on the keyboard in 6 seconds to activate the Split note;
- b. Press [FUNCTION], the indicator light shine. press corresponding [SPLIT ON/OFF] on the keyboard again in 6 seconds to turn off Split note.

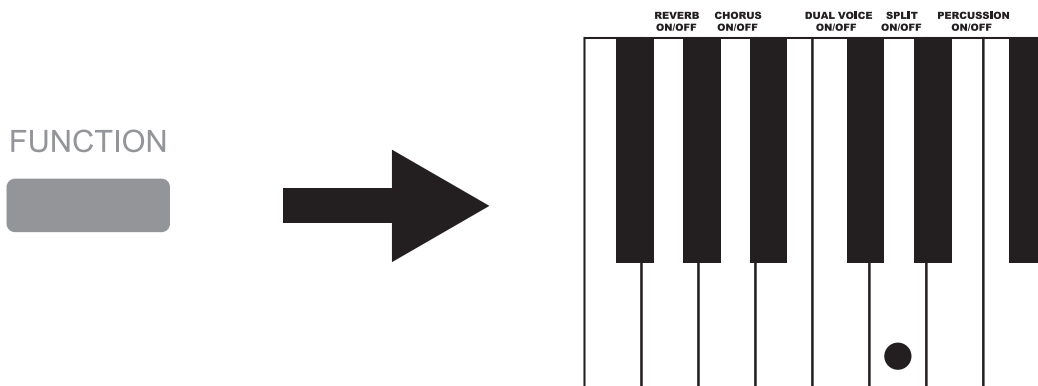

■ How to use Split note

- ① Enter voice mode and select an instrument as the main voice;
- ② Press [SPLIT ON/OFF] to enter the second kind of split voice selection, the default second kind of voice is 049 STRINGS2
- ③ Select another instrument by [▼DATA▲] or number keys;
- ④ Select [Split note] from [MENU],and then adjust the split note by [▼DATA▲].

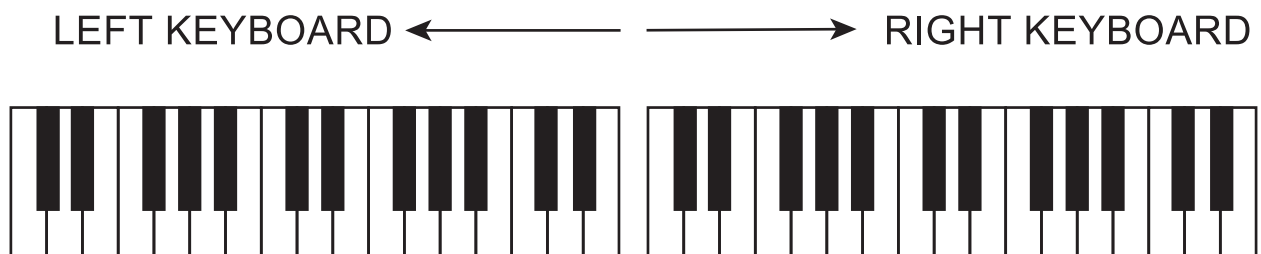

PERCUSSION SETTING

- Press [FUNCTION], the indicator light shine, press corresponding [PERCUSSION ON/OFF] on the keyboard in 6 seconds to activate percussion;
- Press [FUNCTION], the indicator light shine, press corresponding [PERCUSSION ON/OFF] on the keyboard again in 6 seconds to turn off Percussion.

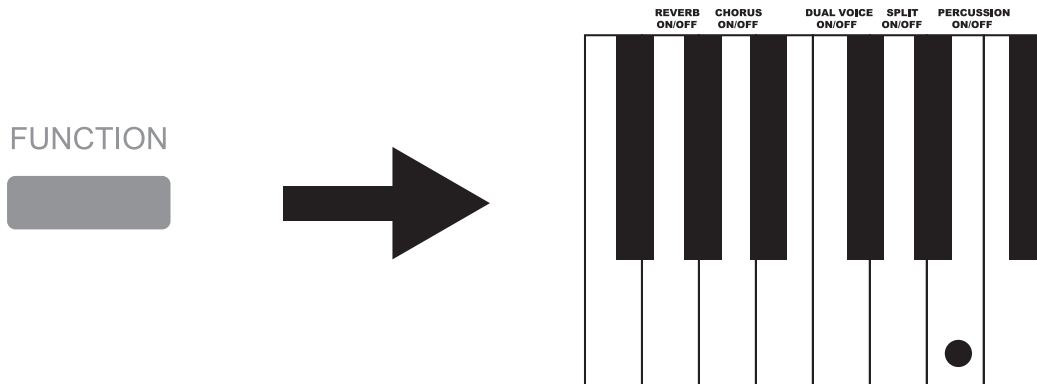

MEMORY SET OF VOICE / RHYTHM

- Select the voice/rhythm you need, press [FUNCTION], the indicator light shine, press any of the keys from [M0-M3], the screen display "Save", means save successfully;
- The instrument saves the current panel function at present on the setting key, press corresponding [R0-R3] to use next time.

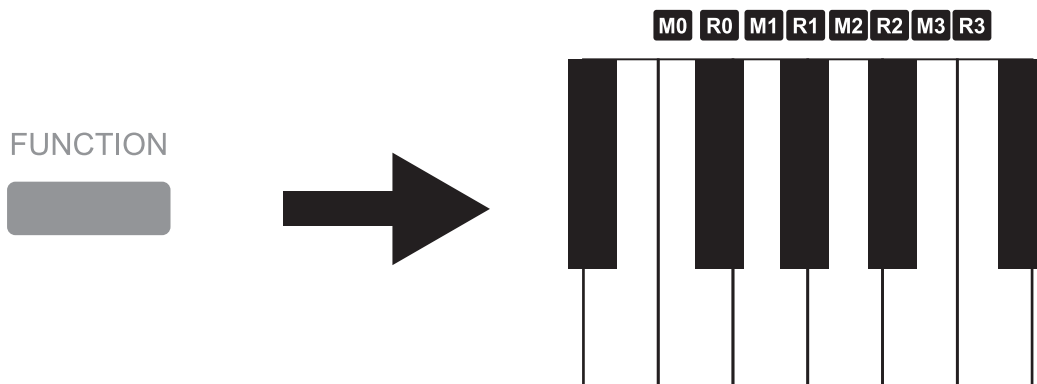

DATA SELECTION

Select voice/rhythm/demo and so on by [▼ DATA ▲], press [▼ DATA ▲] at the same time to enter demo state.

DEMO SONG

60 demo songs

- Press [▼ DATA ▲] at the same time to enter demo state, press at the same time again to stop playing demo songs;
- Press [FUNCTION], the indicator light shine, input 3 digits to display "000-059" and select the corresponding number on the keyboard, the selected demo song will be displayed on the screen, press [FUNCTION] again or without any operation in 6 seconds to play demo song.

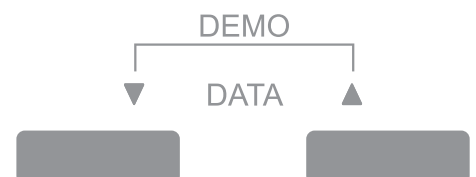

TONE / RHYTHM

1.Voice selection(200 kinds of voice)

- Press [TONE RHYTHM], LCD displays corresponding voice icon, select the voice by [▼ DATA ▲];
- Press [FUNCTION], the indicator light shine, input 3 digits to display "000-199" and select the corresponding number on the keyboard, the selected voice will be displayed on the screen, press [FUNCTION] again or without any operation in 6 seconds to enter the selected voice.

TONE
RHYTHM



2.Rhythm selection

- Press [TONE RHYTHM] again, LCD displays corresponding rhythm icon, select the rhythm by [▼ DATA ▲];
- Press [FUNCTION], the indicator light shine, input 3 digits to display "000-099" and select the corresponding number on the keyboard, the selected rhythm will be displayed on the screen, press [FUNCTION] again or without any operation in 6 seconds to enter the selected rhythm.

TONE
RHYTHM



Attention: long press [TONE RHYTHM] for 2 seconds to get back the grand piano interface.

INTRO / END

- Press [INTRO/END] to enter intro state;
- Press [INTRO/END] again to enter end state.

■ How to use Intro /End

- Press [TONE /RHYTHM] first to select the rhythm you need;
- Press [INTRO/END] to enter intro state, and then press [START/STOP SYNC START] to insert intro for rhythm;
- Press [INTRO/END] when the rhythm is playing, the indicator light shine, insert finished end for the being used rhythm.

INTRO
END



A/FILL 1 B/FILL 2

- Press [VOICE/RHYTHM] first to select the rhythm you need;
- And then press [START / STOP SYNC START] to start to play rhythm;
- 2 kinds of interlude, insert interlude for the being used rhythm by [A/FILL 1][B/FILL 2].

A/FILL 1



B/FILL 2



METRONOME / TEMPO

- Press [METRONOME /TEMPO] to start metronome, default tempo is the tempo of the first rhythm, press [METRONOME /TEMPO] again to quit.

Attention: Restarting the digital piano will restore the default tempo.

- Long press [METRONOME /TEMPO], the indicator light shine to enter metronome tempo, adjust the tempo by [▼ DATA ▲], Adjust extent:20-280 beat/minute;

Attention: Restarting the digital piano will restore the default beat.

METRONOME
TEMPO



RECORD / PLAY

- Press [RECORD], the indicator light on, default to start the metronome to record.
press [METRONOME / TEMPO] to turn off. after recording , press [RECORD], the indicator light off, quit the record state.
- Press [PLAY] , the indicator light on, play the recorded the audio frequency;
- Automatically quits after playing, the indicator off.

RECORD



PLAY



USB / BLUETOOTH

- Insert the USB flash drive to enter read state, select music by [MP3 PLAY] this moment.
- After the digital piano is turned on, it is in Bluetooth standby state by default. After using the phone to search and match the Bluetooth device (PIANO AUDIO) successfully, the music can be played;
- Select music by [⏮], [⏪], press [⏩] to stop playing. Long press [⏮] to turn down the volume; long press [⏩] to turn up the volume.



HEADPHONE JACK

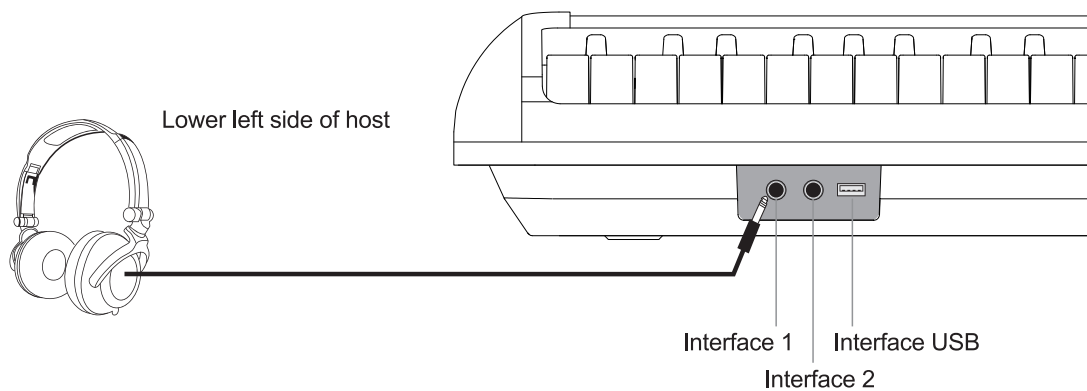

VOICE LIST

N/A	LCD Display
Piano	
000	GrandPno
001	BritePno
002	E,G,Pno
003	HnkyTonk
004	ElecPno1
005	ElecPno2
006	Harpschd
007	Clavi
Mallet	
008	Celesta
009	Glocken
010	MusicBox
011	VbPhone
012	Marimba
013	Xylophon
014	TubBells
015	Dulcimer
Organ	
016	HamndOrg
017	Perc Org
018	Rock Org
019	ChrchOrg
020	ReedOrgn
021	Acordion
022	Harmnica
023	TgAccord
Guitar	
024	GtrNylon
025	GtrSteel
026	Gtr Jazz
027	GtrClean
028	GtrMuted
029	GtrOvrdr
030	Gtr Dist
031	GtrHarmo
Bass	
032	Aco Bass
033	Fig Bass
034	PickBass
035	Fre Bass
036	SlapBas1
037	SlapBas2
038	SynBass1
039	SynBass2
String	
040	Violin
041	Viola
042	Cello
043	Cnt Bass
044	Str trem
045	Str Pizz
046	Harp
047	Timpani
Ensemble	
048	Strings1
049	Strings2

N/A	LCD Display
050	Str Syn1
051	Str Syn2
052	ChoirAah
053	VoiceDoo
054	VoiceSyn
055	Orch Hit
Brass	
056	Trumpet
057	Trombone
058	Tuba
059	Mute Tpt
060	Fr Horn
061	BrassSec
062	BrasSyn1
063	BrasSyn2
Reed	
064	SopraSax
065	Alto Sax
066	Teno Sax
067	Bton Sax
068	Oboe
069	Eng Horn
070	Bassoon
071	Clarinet
Pipe	
072	Piccolo
073	Flute
074	Recorder
075	PanFlute
076	Btl Blow
077	ShkHachi
078	Whistle
079	Ocarina
Lead	
080	SqurWave
081	SawTooth
082	Calliope
083	Chiff
084	Charang
085	VoicLead
086	5th Lead
087	BassLead
Pad	
088	New Age
089	Warm Pad
090	PlySynth
091	ChoirPad
092	BowGlass
093	MetalPad
094	HaloPad
095	Sweep
Effects	
096	Rain
097	SoundTrk
098	Crystal
099	Atmosph
100	Bright

N/A	LCD Display
101	Goblin
102	Echo
103	Sci-Fi
Ethnic	
104	Sitar
105	Banjo
106	Shamisen
107	Koto
108	Kalimba
109	Bagpipe
110	Fiddle
111	Shanai
Percussive	
112	TinkBell
113	Agogo
114	SteelDrm
115	WoodBlk
116	TaikoDrm
117	Melod Tm
118	SynthDrm
119	Revrscym
Sound Effects	
120	GtrNoise
121	Breath
122	SeaShore
123	BrdTweet
124	TelPhone
125	Helicptr
126	Applause
127	GunShot
Folk Percussive	
128	Luo 1
129	Luo 2
130	Luo 3
131	Luo 4
132	Pai Gu
133	Qin
134	BianZho
135	Yang Qin
Folk Plucked	
136	Liu Qin
137	Pi Pa
138	Zho Ruan
139	Da Ruan
140	Yue Qin
141	San Xian
142	Gu Zheng
143	Gu Qin
Folk Wind	
144	Shen 1
145	Shen 2
146	Na Zi 1
147	Na Zi 2
148	Bi Li
149	Guan Zi1
150	Guan Zi2
151	Ba Wu

N/A	LCD Display
Folk Wind 2	
152	Di Zi 1
153	Di Zi 2
154	Hu Lu Si
155	Pai Xiao
156	S Xiao
157	Xiao
158	Kou Di
159	Xun
Folk Bowed String	
160	Gao Hu
161	Er Hu
162	Zhong Hu
163	MaTouQin
164	Ban Hu
165	Jing Hu
166	Hu Ense1
167	Hu Ense2
Piano Group 2	
168	Piano W
169	Piano D
170	HnkTk W
171	DetunEP
Organ 2	
172	DetunOr
173	Organ
174	Bandoneo
Guitar 2	
175	Ukulele
176	Mandolin
177	MellowGt
178	HawaiiGt
179	ChorusGt
180	Funk Gt
181	Feed Gt
Bass & Electronic Music	
182	Synth 1
183	Synth 2
184	Synth 3
185	Synth 4
186	Synth 5
Synthetic	
187	SpacVioc
188	Syn Malt
189	EchoBell
190	Echo Pan
Percussive 2	
191	Castanet
192	ConcerBD
193	808 Tom
194	ElecPerc
Sound Effects	
195	Wind
196	Stream
197	Dog
198	Horse
199	Door

RHYTHM LIST

N/A	Name
000	8 BEAT 1
001	8 BEAT 2
002	8 BEAT 3
003	8 BEAT 4
004	8 BEAT 5
005	8 BEAT 6
006	8 BEAT 7
007	8 BEAT 8
008	16BEAT 1
009	16BEAT 2
010	16 EAT 3
011	16BEAT 4
012	16BEAT 5
013	16BEAT 6
014	16BEAT 7
015	16BEAT 8
016	POP 1
017	POP 2
018	POP 3
019	POP 4
020	BALLAD 1
021	BALLAD 2
022	BALLAD 3
023	BALLAD 4
024	SWINJAZZ
025	JAZZ 1
026	JAZZ 2
027	LANGE
028	SWING
029	RAGTIME
030	68BLUES
031	4.4BLUES
032	5.4BEAT
033	BOOGIE

N/A	Name
034	SOULSHFF
035	BEBOP
036	GOSPLE
037	SW WALTZ
038	B BOOGIE
039	ROCK 1
040	ROCK 2
041	ROCK 3
042	ROCK 4
043	ROCK 5
044	ROCK 6
045	ROCK 7
046	FUNK 1
047	FUNK 2
048	FUNK 3
049	FUNK 4
050	FUNK 5
051	FUNK 6
052	EDANCE 1
053	EDANCE 2
054	DANCE 1
055	DANCE 2
056	DANCE 3
057	DISCO
058	R&B 1
059	R&B 2
060	R&B 3
061	R&B 4
062	RAP 1
063	RAP 2
064	FOXTROT1
065	FOXTROT2
066	FOXTROT3
067	FOXTROT4

N/A	Name
068	FOXTROT5
069	LATIN 1
070	LATIN 2
071	REGGAE
072	MODERN
073	SAMBA
074	CHACHA
075	TANGO
076	RUMBA
077	MAMBO
078	SALSA
079	ARABIAN1
080	MACARENA
081	MUSETTE
082	XINJIANG
083	YUNNAN
084	XIZANG
085	COUNTRY 1
086	COUNTRY 2
087	C BALLAD
088	CBROTHER
089	CON POP
090	SHUFFLE
091	C SWING
092	CTWOSTEP
093	C WALTZ
094	WALTZ 1
095	WALTZ 2
096	TR WALTZ
097	VN WALTZ
098	MARCH
099	POLKA

DEMO SONG LIST

N/A	Name	N/A	Name
000	2-INVENT	030	WIGNLIED
001	PIZZPOLK	031	MERCY
002	ARABE	032	DRMINSMR
003	UNDERSEA	033	MINUET
004	HAVANERA	034	JTTWORLD
005	MUSICBOX	035	HOLYHALL
006	HGRDANCE	036	SONG SPR
007	SL AMOUR	037	JAMBALAY
008	LEAF RAG	038	AVEMARIA
009	ANNIELAU	039	DUCKS
010	JUNESMBA	040	PLSDANCE
011	MACARENA	041	LONDONHON
012	FUNK	042	GRENSLEV
013	WALTZ	043	HORSERAC
014	ARIRANG	044	SOMALI
015	BINGO	045	SUNNYDAY
016	HOMETOWN	046	LAZYBIRD
017	WEELSBUS	047	CHRYSAN
018	REGGAE	048	SATNDOLL
019	TEMPANI	049	DSYPUPPY
020	LEMON TR	050	SOMEWHERE
021	G ISLAND	051	DONNALEE
022	OCSUITE	052	CHERRY
023	DERRYAIR	053	EARLYAUT
024	RONDO BR	054	BLUES
025	NUTCRACK	055	RUNSUMER
026	JMFLOWER	056	DANCEYOU
027	ROSESONG	057	GRAYMARE
028	CHILDBOR	058	SYMPHONY
029	DANSE NP	059	TURKEY

Problem	Reasons / Solution
When the power is turned on or turned off, a sound calling "pu" is produced.	This is normal and there is no need to worry.
When the power is turned on, pressing the keys do not make any sound.	Make sure that the main volume is in the appropriate position and no devices connect to the output jack. Both can cause the speaker system disconnects.
Note quality is slightly different from note quality under the same voice.	This is normal. This is because the voice samples from different range and produces different sound quality.
While using the damper function, some notes sustain long but some sustain short.	This is normal. The damper of different voice of this instrument has been set to the best length.
Low volume	Make sure that the main volume control button is set in the appropriate position.
Some MIDI data can not be send exactly (even though MIDI connection is absolutely right)	This is normal. It is related to the initial setting state of the instrument.
When using a phone or the phone is near, there will be some noises from the horn of the instrument.	Phones can cause interference. To avoid the noise, turn off the phone or stay away from the instrument to use it.
The pitch does not match the position of the key on the keyboard when you are playing.	Maybe you have turned on split or transpose. If so, you can turn off split or transpose; or you can turn off the power to restart.
The voice can not be changed and the pitch does not match the position of the key on the keyboard when you are playing.	Maybe you have turned on split. If so, you can turn off split or turn off the power to restart.
Playing demo songs, sound distortion or discontinuous.	Maybe you have played loudly for a long time. The power amplifier is too hot to start the self protection system. Turn down or turn off for a while.
Two kinds of voice sound at the same time, when playing.	Maybe you have turned on dual. If so, turn off dual, it will be OK.

Attention:

The equipment has been tested. Conform to national safety regulations and EMC and so on. Radio communications may interfere with the device, or the device may interfere with radio or television reception, Users may take one or more of the following measures to correct interference:

- Reposition or change the receiving antenna.
- Increase direct isolation between the equipment and receiver.
- Try to change a socket.
- Consult dealers or experienced radio and television technicians.

 **Warning**

Improper changes or modifications may affect the normal operation.

