

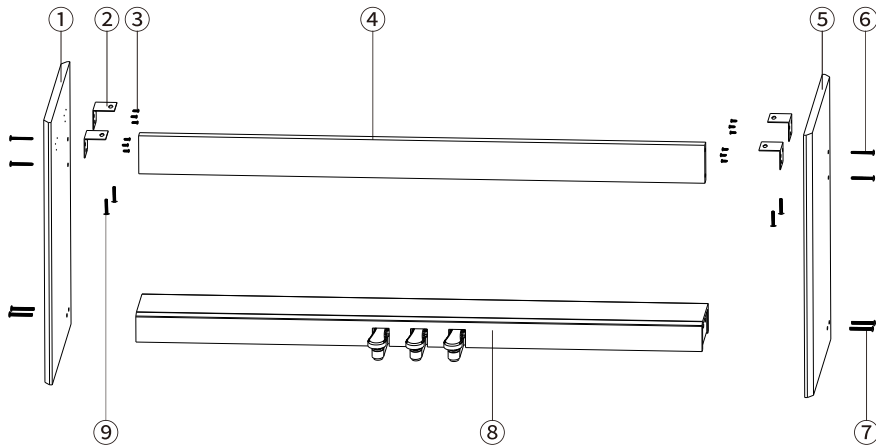

First of all, please check and confirm whether the components are complete.
Please prepare a cross screwdriver for the piano stand assembly.

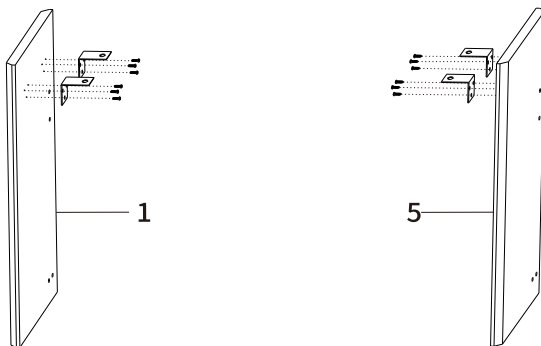

No.	Name	Quantity
1	Left stand plate	1 PCS
2	L-shaped brackets	4 PCS
3	M4x12mm Screw	12 PCS
4	Back plate	1 PCS
5	Right stand plate	1 PCS
6	M5x50mm Screw	4 PCS
7	M6x50mm Screw	4 PCS
8	Pedal box	1 PCS
9	M5x30mm screw	4 PCS



① Use 12 pcs M4x12mm screws to fix the 4 pcs L-shaped brackets on the left and right stand plate (1, 5) with the cross screwdriver.

Graph	NO.	Quantity
	2	4
	3	12

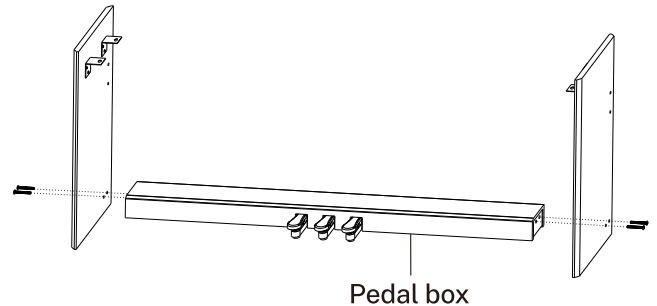

② Use 4 pcs M6x50mm screws to fix the pedal box with left and right stand plate.

Graph	NO.	Quantity
	7	4

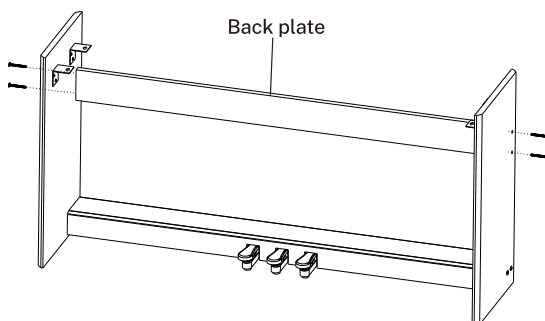

③ Use 4 pcs M5x50mm screws to fix back plate with left and right stand plate. Then, the piano stand is completed.

Graph	NO.	Quantity
	6	4

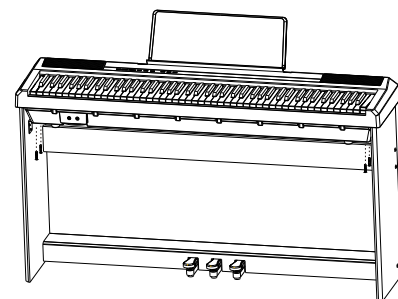

④ Fixed digital piano on the piano stand with 4 pcs M5X30mm screws.

Graph	NO.	Quantity
	9	4



Donner Technology Co., Ltd.

Email: donnerdeal@gmail.com

Facebook: <http://facebook.com/Donnerdeal.com>

www.idonner.com / www.donnerdeal.com