

# Goldair™



## Operating Instructions

### USB Desk Fan



Model: GCPDF120

# General Care and Safety Guide

**Thank you for choosing this Goldair product. This Goldair appliance has been designed and manufactured to high standards of engineering and with proper use and care, as described in this leaflet, will give you years of useful service. Please read these instructions carefully and keep them for future reference.**

1. This appliance is not intended for use by persons (including children) with reduced physical, sensory or mental capabilities, or lack of experience and knowledge, unless they have been given supervision or instruction concerning use of the appliance by a person responsible for their safety.
2. Children should be supervised to ensure that they do not play with the appliance.
3. The appliance must only be supplied at safety extra low voltage corresponding to the marking on the appliance.
4. Ensure that the fan is switched off from the supply mains before removing the guard.
5. Use only the voltage specified on the rating plate of the appliance.
6. Keep all objects at least 300mm from the front, sides and rear of the appliance
7. This appliance is intended for household use only and not for commercial or industrial use.
8. Use this appliance only as described in this manual. Any other use is not recommended by the manufacturer and may cause fire, electric shock or injury.
9. The common cause of overheating is deposits of dust or fluff in the appliance. Ensure these deposits are removed regularly by unplugging the appliance and vacuum cleaning the air vents and grills.
10. Always unplug appliance when not in use.
11. When the appliance has been unpacked, check it for transport damage and ensure all parts have been delivered. If parts are missing or the appliance has been damaged, contact the Goldair Customer Services Team.
12. If your appliance does not work, or is not working properly, contact the place of purchase. Repair work on the appliance by unqualified persons can cause serious risk to the user.
13. Ensure hands are dry before handling the plug or the main unit.
14. Carry out regular checks of the USB supply cord to ensure no damage is evident.
15. Ensure that the cord is fully extended (not coiled) while in use.
16. Avoid contact with the moving parts. Keep hands, hair, clothing, away from blade of the fan during operation to reduce the risk of injury to person and/or damage to the unit.
17. Switch off when moving.
20. Never place appliance close to radiant heat source.
21. Never operate in areas where petrol, paint or other flammable liquids are used or stored.
22. Never insert or allow foreign objects to enter any ventilation or exhaust opening, as this may cause an electric shock, fire or damage to the appliance.

# General Care and Safety Guide

23. Never use abrasive cleaning products on this appliance. Clean with a damp cloth (not wet) rinsed in hot soapy water only. Always remove The USB plug from the power supply before cleaning.
24. Never connect the appliance to USB power supply until completely assembled and adjusted.
25. Never remove plug from the USB power supply until the appliance has been switched off.
26. Never remove plug from the USB power supply by pulling cord – always grip plug.
27. Never use this appliance in the immediate surrounds of a bath, a shower, or a swimming pool or other liquids. The appliance must not be immersed in any liquids.
28. Due to the risk of injury, never use this appliance for any purpose other than its intended use. This appliance is intended for use in household and similar applications such as staff kitchen areas in shops, offices and other working environments; farm houses, by clients in hotels, motels, bed and breakfast type environments and other residential type environments
29. Never use this appliance outdoors.
30. Never operate the appliance with a damaged cord or plug, after it malfunctions, or if it has been damaged in any manner. Have the appliance checked and repaired by a qualified electrician if repair is necessary.
31. Never place the unit in wardrobes or other enclosed spaces as this may cause fire hazards.

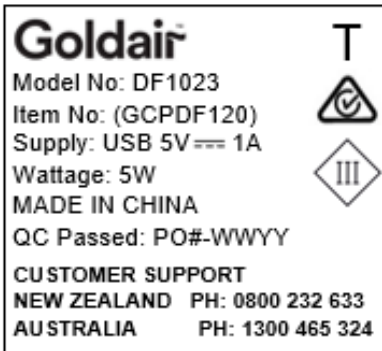

# Operating your Fan

Always choose a safe location for the fan, keeping in mind the safety precautions outlined. Ensure all packaging has been removed from the unit before use. This appliance requires no installation, it should be used solely as a portable appliance.

**WARNING:** Keep all objects at least 300mm from the front, sides and rear of the appliance

**IMPORTANT! NEVER COVER THIS APPLIANCE!**

## CHARGING YOUR FAN

The fan can be charged using the USB cable provided and a compatible electronic device or DC 5V 1.5A USB power adaptor. Using chargers with incorrect power delivery (voltage and current) can cause damage to the battery, including overheating, that can lead to fires.

1. Place the fan on a flat surface, close to a USB power outlet port.
2. Connect the fan to the USB power outlet port by using the USB cable supplied. Ensure the cable is fully unwound.
3. Disconnect the USB cable from the USB power outlet and the fan once charged. If using a USB power adaptor, switch off the power from the power point and unplug the USB power adaptor prior to disconnecting the USB cable.

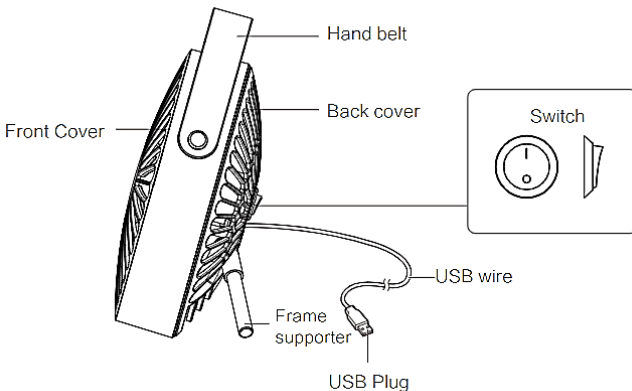

Ensure the speed control is at OFF position before plugging the power cord into the USB power supply.

Move the frame holders (legs) to an appropriate angle and place the fan onto a stable surface.

## Fan control switch

The control switch positions are:

0 = OFF

I = ON

# Operating your Fan

## WARNING

- Don't charge or store batteries or devices on combustible or insulating surfaces such as beds, sofas, or carpet, and keep them away from highly flammable materials such as blankets, clothing, and paper.
- To protect against electric shock, do not immerse the USB cable, USB power adaptor or fan in water or any other liquid or allow moisture to come in contact with any parts unless it is recommended in the cleaning instructions.
- It is recommended to regularly inspect the fan, USB cable for any signs of wear, damage or overheating.
- Do not use the fan, USB cable and power adaptor if they become damaged in any way.
- During electrical storms, while charging, the USB adaptor should be disconnected from the power source at the wall socket to prevent any electrical surges that may arise during a storm and which may inadvertently cause damage to the USB adaptor and electronic componentry inside the fan.

## WARNING! This product contains lithium-ion batteries.

### **DO NOT DISPOSE OF LITHIUM-ION BATTERIES IN ORDINARY RUBBISH.**

*Batteries must be recycled or disposed of properly.*

*Consult your local council for information regarding available recycling and/or disposal options.*

Separate Collection Symbol (Batteries)



- Li-ion batteries are generally safe, but if they are mistreated or used incorrectly, they can catch fire or explode.
- Do not place battery appliances or their batteries near fire or heat. This will reduce the risk of explosion and possibly injury.
- Charge only with a battery charger that meets the specification of the appliance - USB 1.5A
- Do not attempt to destroy or disassemble battery pack or remove any of its components.
- Never touch both terminals with metal objects and/or body parts as short circuit may result
- Keep away from children.
- Failure to comply with these warnings could result in fire and or serious injury.

# Cleaning

The fan requires regular cleaning to ensure trouble free operation.

Unplug the fan from the mains supply before cleaning.

Use a damp cloth (not wet) to wipe the exterior of the fan to remove dust and dirt.

Use a vacuum cleaner to remove dust and fluff from around the grills.

Ensure the fan is dry before plugging back into the mains supply.

To clean the fan, turn the back cover in an anti-clockwise direction and pull the cover out (as shown in below pictures).

Reassemble by placing the back cover on to the front cover and lock in position in a clockwise direction.

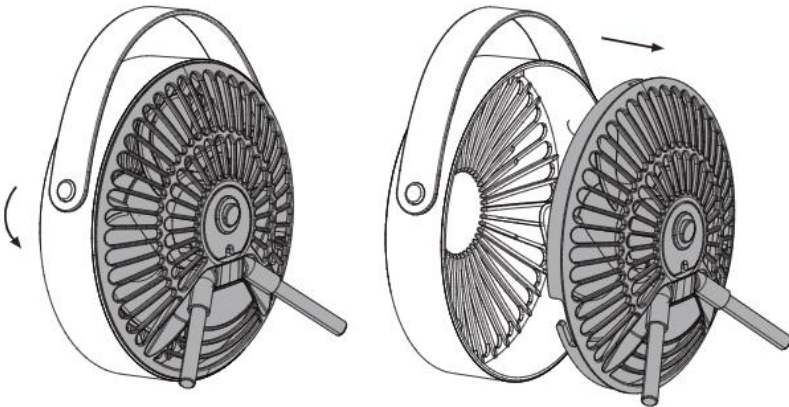

## PROOF OF PURCHASE

To receive warranty retain receipt as proof of purchase. (Refer to back of booklet).

# Goldair™

## SUPPORT AND TECHNICAL ADVICE

**Goldair – New Zealand**  
Monday – Friday 8am-5pm  
Phone +64 (0)9 917 4000  
Phone 0800 232 633  
info@cdb.co.nz

**Goldair – Australia**  
Monday – Friday 8am-5pm  
Phone +61 (0)3 9365 5100  
Phone 1300 465 324  
info@cdbgoldair.com.au



# One Year Warranty

Thank you for purchasing this Goldair product. Your product is warranted against faults and manufacture when used in normal domestic use for a period of **one year**. In non-domestic use Goldair limits the voluntary warranty to **three months**.

Goldair undertake to repair or replace this product at no charge if found to be defective due to a manufacturing fault during the warranty period.

This warranty excludes damage caused by misuse, neglect, shipping accident, incorrect installation, or work carried out by anyone other than a qualified electrical service technician.

PLEASE KEEP YOUR RECEIPT AS THIS WILL HELP VERIFY YOUR WARRANTY.

The benefits to you given by this warranty are in addition to other rights and remedies available to you under a law in relation to the goods or services to which this warranty relates.

In Australia, our goods come with guarantees that cannot be excluded under the Australian Consumer Law. You are entitled to a replacement or refund for a major failure and compensation for any other reasonably foreseeable loss or damage. You are also entitled to have the goods repaired or replaced if the goods fail to be of acceptable quality and the failure does not amount to a major failure.

In New Zealand this warranty is additional to the conditions and guarantees of the Consumers Guarantee Act (1993).

**Goldair – New Zealand**

CDB Goldair  
PO Box 100-707  
N.S.M.C  
Auckland , 0745

Phone +64 (0)9 917 4000  
Phone 0800 232 633  
[www.goldair.co.nz](http://www.goldair.co.nz)

**Goldair – Australia**

CDB Goldair Australia Pty  
PO Box 574  
South Morang  
Victoria, 3752

Phone +61 (0)3 9365 5100  
Phone 1300 GOLDAIR (1300 465 324)  
[www.goldair.com.au](http://www.goldair.com.au)

**Goldair One Year Warranty** (IMPORTANT: Please complete and retain this warranty card)

Name \_\_\_\_\_  
\_\_\_\_\_

Address \_\_\_\_\_  
\_\_\_\_\_  
\_\_\_\_\_  
\_\_\_\_\_

Place Of Purchase \_\_\_\_\_ Date of Purchase \_\_\_\_\_

Name Of Product \_\_\_\_\_ Model Number \_\_\_\_\_

Attach a copy of the purchase receipt to this warranty card

Due to continual design improvements, the product illustrated in this User Manual may differ slightly from the actual product.

# Goldair™



CDB  Goldair™

New Zealand  
PO Box 100707,  
North Shore Mail Centre,  
Auckland, 0745  
[www.goldair.co.nz](http://www.goldair.co.nz)

Australia  
PO Box 574,  
South Morang,  
Victoria, 3752  
[www.goldair.com.au](http://www.goldair.com.au)