

MERCEDES-BENZ
METRIS



UPFIT GUIDE



**THE PERFECT FIT
FOR YOUR
TOUGHEST JOBS**

HELPING MOBILE TECHNICIANS WORK MORE EFFECTIVELY BY PROVIDING ORGANIZED STORAGE SOLUTIONS

AT RANGER DESIGN, WE BELIEVE MORE IS POSSIBLE.

We believe work vehicles and the technicians that drive them can become more organized, more efficient, more productive and more profitable. At Ranger Design we're committed to bringing you the products and services that make that possible.

More means helping you choose the right work van for your application, as well as giving you engineering support and expert advice to help design the most efficient work space in your new vehicle.

More also means getting that new van outfitted and on the road faster, so you can start using it for the reason you bought it.

We're committed to bringing you more, because we believe more is possible.





CONTRACTOR
P. 6 – 7



SERVICE
P. 8 – 9



ELECTRICAL
P. 10 – 11



HVAC
P. 12 – 13



DELIVERY
P. 14 – 15



ALUMINUM
P. 16 – 17



DRAWERS
P. 18



ACCESSORIES
P. 19 – 21



LADDER RACKS
P. 22

Large Distributor Network Across the Continent

Buy Ranger Design Quickship service is available through your local distributor. rangerdesign.com/find-distributor

Lead Time Quickship orders placed with Ranger Design before 1PM EST, will ship from our factory in the next business day.



All products shown in this upfit guide are available on Quickship

HOW TO USE THE LAYOUT GUIDE

INSIDE ROOF HEIGHT

To determine the maximum shelf height that can be used in the van.

PARTITION DEPTH

This indicates the space taken up by our partition for this vehicle. Please note that this measurement is determined by the partition that encroaches the most. Some partitions may take up less space. Take note that this measurement may not necessarily be on the floor.

DOOR OPENING

To determine where shelving will land in relation to the door opening. Use this measurement to determine the space available for drawer units.

DIMENSIONS IN RED

These dimensions indicate unique measurements for each wheelbase. Use red dimensions to determine the exact wheelbase of your van.

FLOOR SPACE

This area is usable floor space but due to curvature of the van there may not be the same available area at the roof. Please measure actual van for specific measurement at roof.

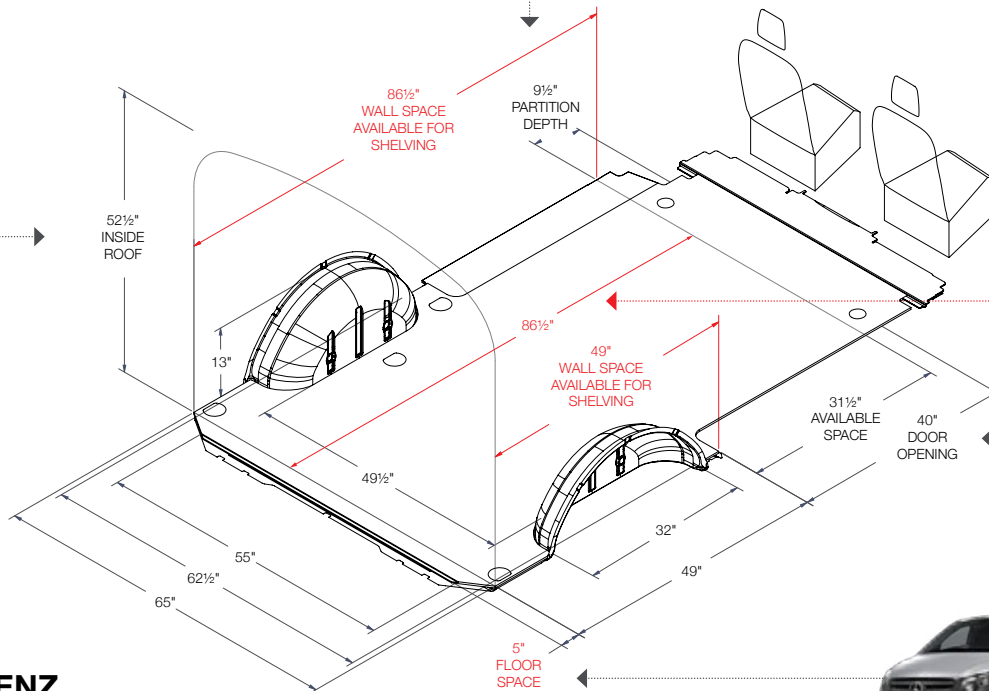

MERCEDES-BENZ METRIS

Regular 126" Wheelbase



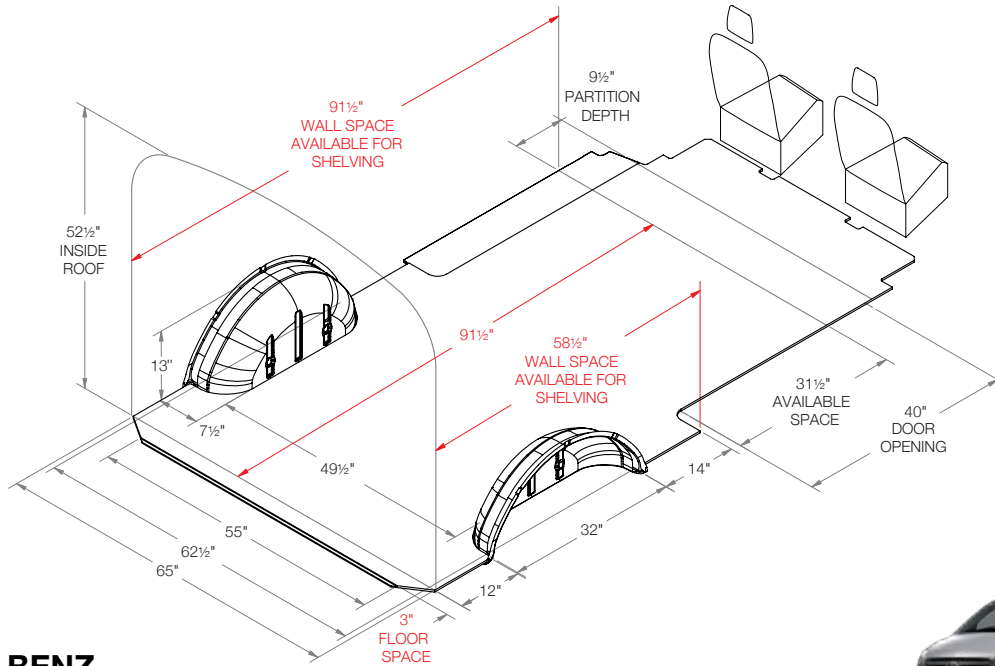

MERCEDES-BENZ METRIS

Long 135" Wheelbase

Storage zones

- A** - Driver Side Rear
- B** - Driver Side Front
- C** - Partition and Slide Door
- D** - Passenger Side
- E** - Roof
- F** - Partition

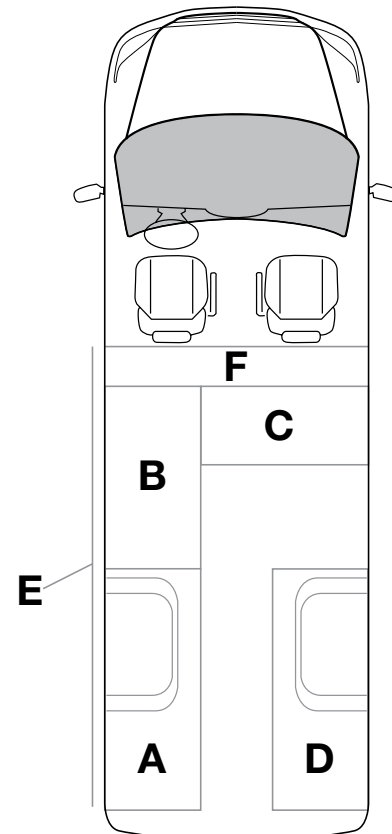

Regular

CONTRACTOR

CONTRACTOR

MMR-10

126" OR 135" WHEELBASE



> Standard Roof

Qty	Part #	Description
1	6070	6" Hook, 3" opening, painted
1	C10-MM	Contoured steel partition with perforated window
2	N4-RS36-3	Steel shelving unit for low roof van 14" D x 36" W x 44.5" H

The Base package is designed to fit in a Metris with dual sliding doors.

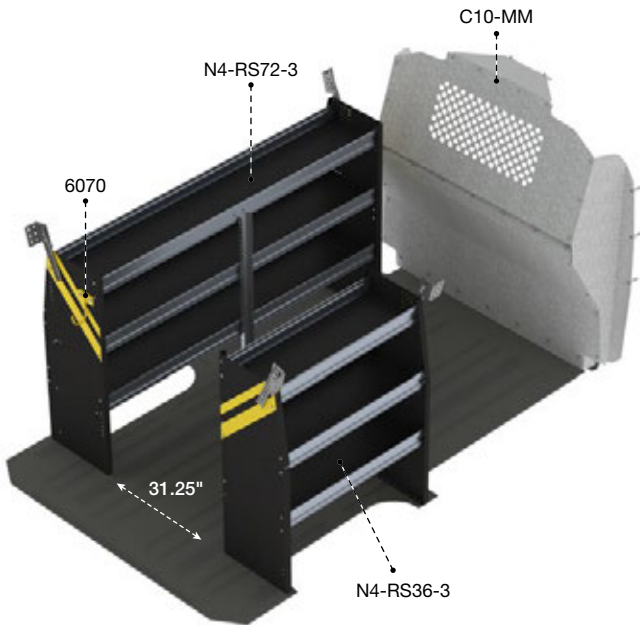
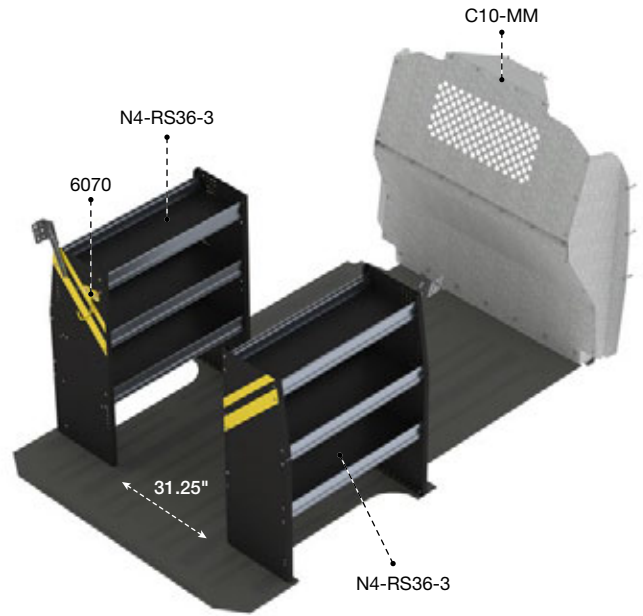

MML-10

126" OR 135" WHEELBASE



> Standard Roof

Qty	Part #	Description
1	6070	6" Hook, 3" opening, painted
1	C10-MM	Contoured steel partition with perforated window
1	N4-RS36-3	Steel shelving unit for low roof van 14" D x 36" W x 44.5" H
1	N4-RS72-3	Steel shelving unit for low roof van 14" D x 72" W x 44.5" H

The Deluxe package is designed to fit in a Metris with a single sliding door.



VISIT OUR WEBSITE FOR
OUR FULL-LINE OF PARTITIONS

MML-10

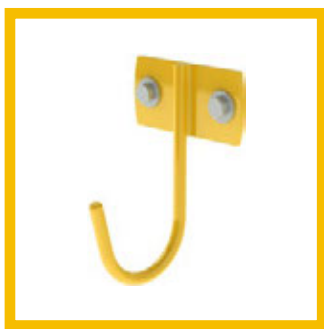

6070

6" Hook,
3" opening,
painted



MMR-16

126" OR 135" WHEELBASE

> Standard Roof



Qty	Part #	Description
1	6070	6" Hook, 3" opening, painted
1	6072	8" Swivel hook, 4" opening, painted
3	62-U1114	14" Deep plastic bin
1	62-UDR12	Set of 5 dividers for a 12" shelf
1	62-UDR14	Set of 5 dividers for a 14" shelf
1	C10-MM	Contoured steel partition with perforated window
2	N4-RS36-3	Steel shelving unit for low roof van 14" D x 36" W x 44.5" H
1	X50-B	Compact 2-drawer unit

The Base package is designed to fit in a Metris with dual sliding doors.

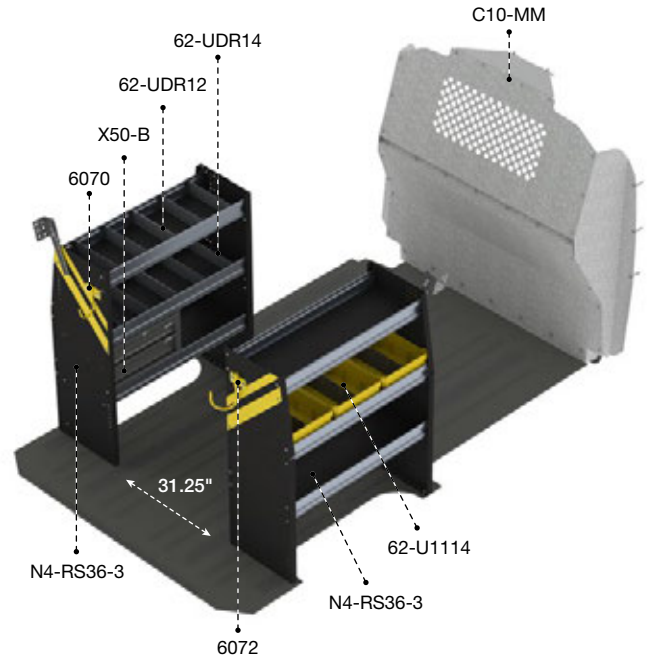

SERVICE

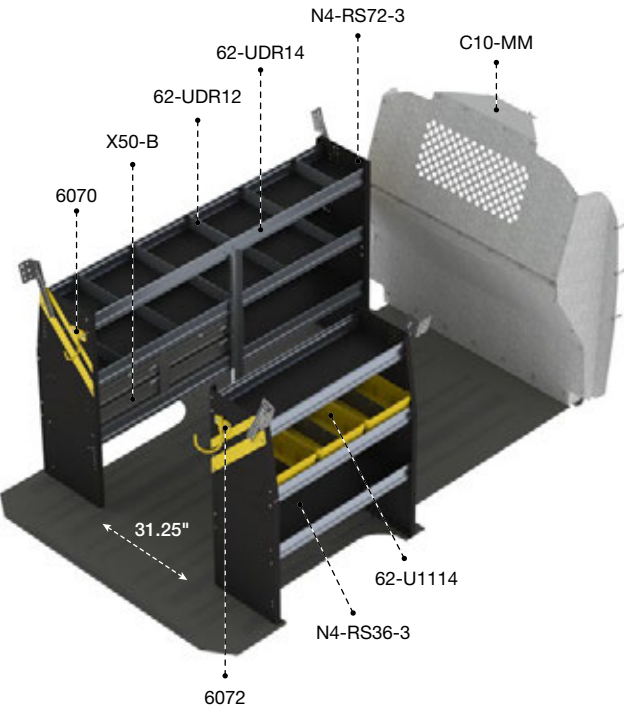

MML-16

126" OR 135" WHEELBASE

> Standard Roof



Qty	Part #	Description
1	6070	6" Hook, 3" opening, painted
1	6072	8" Swivel hook, 4" opening, painted
3	62-U1114	14" Deep plastic bin
1	62-UDR12	Set of 5 dividers for a 12" shelf
1	62-UDR14	Set of 5 dividers for a 14" shelf
1	C10-MM	Contoured steel partition with perforated window
1	N4-RS36-3	Steel shelving unit for low roof van 14" D x 36" W x 44.5" H
1	N4-RS72-3	Steel shelving unit for low roof van 14" D x 72" W x 44.5" H
2	X50-B	Compact 2-drawer unit

The Deluxe package is designed to fit in a Metris with a single sliding door.



VISIT OUR WEBSITE FOR
OUR FULL-LINE OF PARTITIONS

MML-16



6072

8" Swivel hook,
4" opening, painted



X50-B

2 Drawer cabinet



62-U1114

14" Deep plastic bin
with a center divider

FOR MORE ACCESSORIES, SEE PAGE 20.

MMR-11

126" OR 135" WHEELBASE



> Standard Roof

Qty	Part #	Description
1	6063	Paper holder, extra deep, 5 slots
1	6070	6" Hook, 3" opening, painted
1	6072	8" Swivel hook, 4" opening, painted
3	62-U1112	12" Deep plastic bin
2	62-UDR14	Set of 5 dividers for a 14" shelf
1	7124	Reel holder with two 5/8" diameter rods
1	77-U1036	Adjustable shelving door unit - 33" W - for 36" & 72" shelves
1	C10-MM	Contoured steel partition with perforated window
2	N4-RS36-3	Steel shelving unit for low roof van 14" D x 36" W x 44.5" H
1	X50-C	Compact 3-drawer unit

The Base package is designed to fit in a Metris with dual sliding doors.

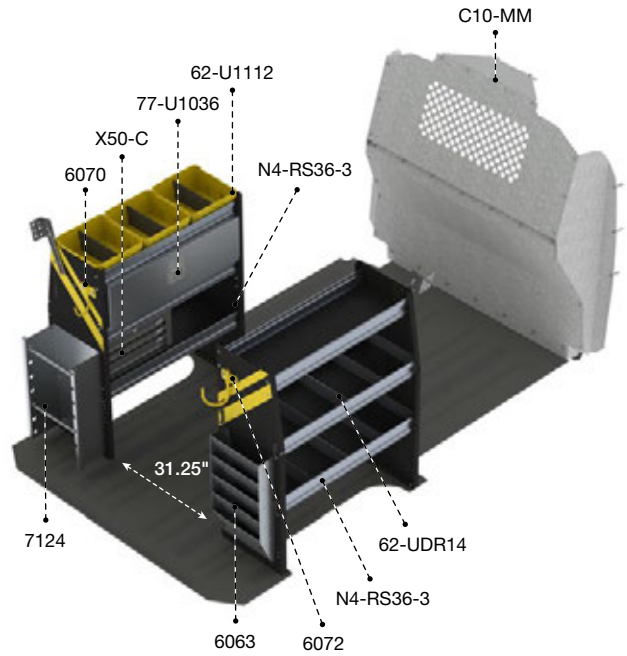

ELECTRICAL

MML-11

126" OR 135" WHEELBASE



> Standard Roof

Qty	Part #	Description
1	6063	Paper holder, extra deep, 5 slots
1	6070	6" Hook, 3" opening, painted
1	6072	8" Swivel hook, 4" opening, painted
6	62-U1112	12" Deep plastic bin
2	62-UDR14	Set of 5 dividers for a 14" shelf
1	7124	Reel holder with two 5/8" diameter rods
2	77-U1036	Adjustable shelving door unit - 33" W - for 36" & 72" shelves
1	C10-MM	Contoured steel partition with perforated window
1	N4-RS36-3	Steel shelving unit for low roof van 14" D x 36" W x 44.5" H
1	N4-RS72-3	Steel shelving unit for low roof van 14" D x 72" W x 44.5" H
1	X50-B	Compact 2-drawer unit
1	X50-C	Compact 3-drawer unit

The Deluxe package is designed to fit in a Metris with a single sliding door.

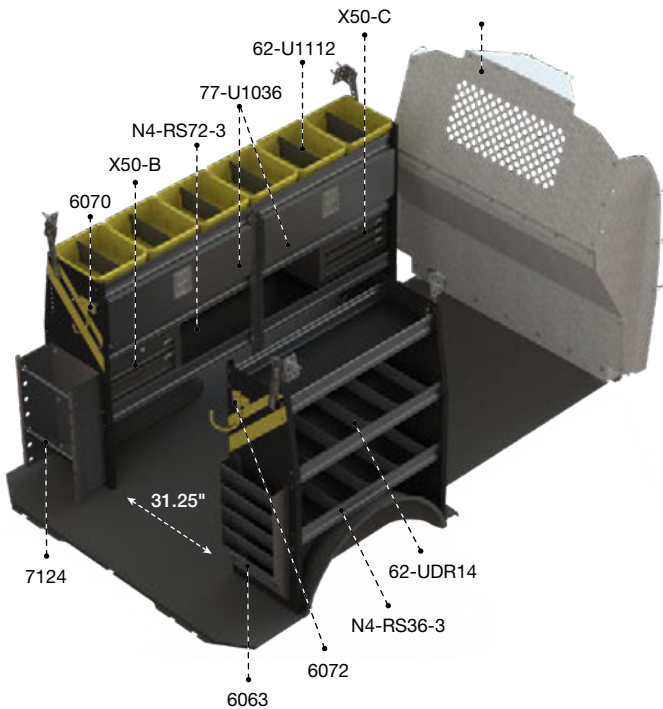



VISIT OUR WEBSITE FOR
OUR FULL-LINE OF PARTITIONS

MML-11



**62-U1110, 62-U1112,
62-U1114**

Plastic bins with a center divider
Available in 10", 12" or 14" depths



62-U1212

2 Cross dividers for bin
Fits all size bins



77-U1042

Adjustable shelving door
unit 39" wide for a 84" shelf

FOR MORE ACCESSORIES, SEE PAGE 20.

MMR-12

126" OR 135" WHEELBASE

> Standard Roof



Qty	Part #	Description
1	6008	3 Tier refrigerant rack for large bottles
1	6063	Paper holder, extra deep, 5 slots
1	6070	6" Hook, 3" opening, painted
1	6072	8" Swivel hook, 4" opening, painted
1	6088	Large aluminum bottle holder, with two black nylon straps
2	62-UDR14	Set of 5 dividers for a 14" Shelf
3	62-U1112	12" deep plastic bin
1	77-U1036	Adjustable shelving door unit - 33" W - for 36" & 72" shelves
1	C10-MM	Contoured steel partition with perforated window
2	N4-RS36-3	Steel shelving unit for low roof van 14" D x 36" W x 44.5" H
1	X50-B	2 Drawer Cabinet

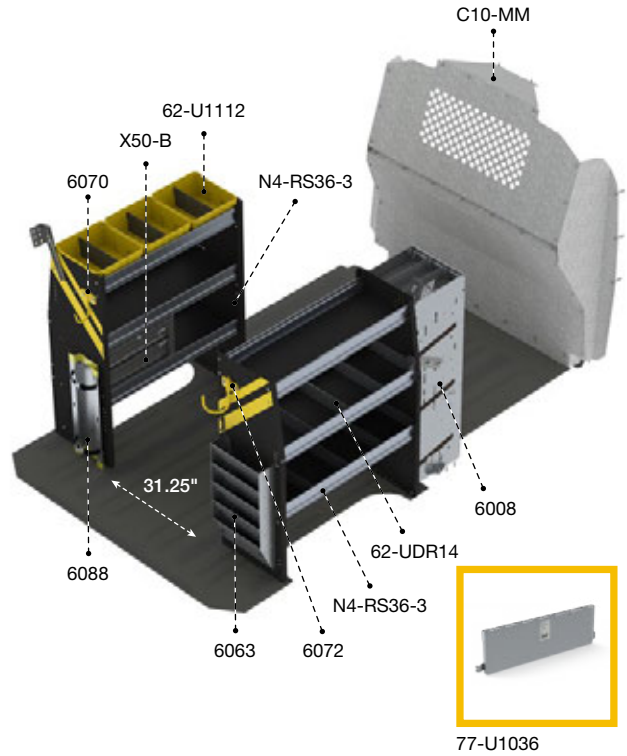

The Base package is designed to fit in a Metris with dual sliding doors.

HVAC

MML-12

126" OR 135" WHEELBASE

> Standard Roof

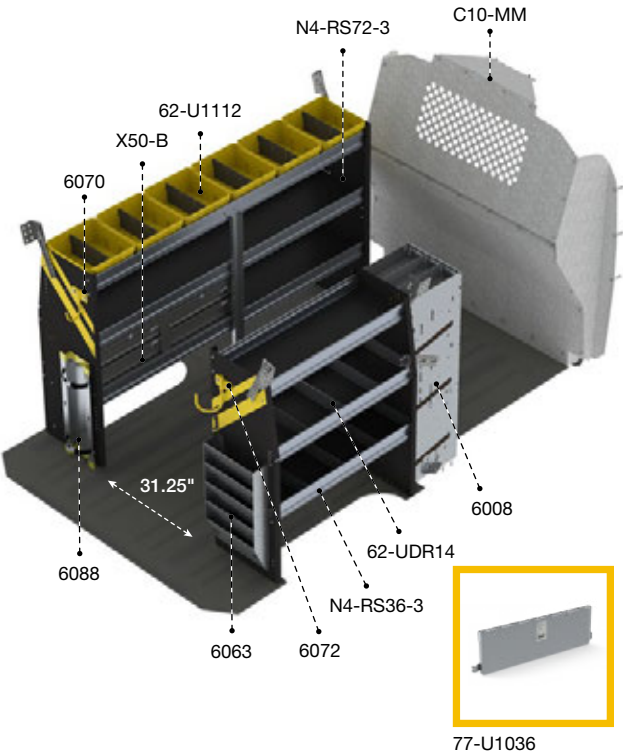

Qty	Part #	Description
1	6008	3 Tier refrigerant rack for large bottles
1	6063	Paper holder, extra deep, 5 slots
1	6070	6" Hook, 3" opening, painted
1	6072	8" Swivel hook, 4" opening, painted
1	6088	Large aluminum bottle holder, with two black nylon straps
2	62-UDR14	Set of 5 dividers for a 14" Shelf
6	62-U1112	12" deep plastic bin
1	77-U1036	Adjustable shelving door unit - 33" W - for 36" & 72" shelves
1	C10-MM	Contoured steel partition with perforated window
1	N4-RS36-3	Steel shelving unit for low roof van 14" D x 36" W x 44.5" H
1	N4-RS72-3	Steel shelving unit for low roof van 14" D x 72" W x 44.5" H
2	X50-B	2 Drawer Cabinet

The Deluxe package is designed to fit in a Metris with a single sliding door.



HVAC



VISIT OUR WEBSITE FOR OUR FULL-LINE OF PARTITIONS

MML-12



62-UDR10, 62-UDR12, 62-UDR14

Set of 5 dividers for a 10", 12" or 14" shelf

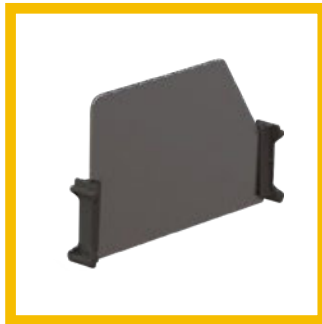

62-UDH14

Set of 5 high dividers for a 14" shelf



6088

Large aluminum bottle holder, with two black nylon straps



6008

3 Tier refrigerant rack for large bottles

FOR MORE ACCESSORIES, SEE PAGE 20.

MMR-19
 126" OR 135" WHEELBASE
 > Standard Roof



Qty	Part #	Description
1	C13-MM	Wire mesh partition
2	F4-RA36-2	Fold-away unit, 2 levels, 22" D x 36" W x 47" H

The Base package is designed to fit in a Metris with dual sliding doors.

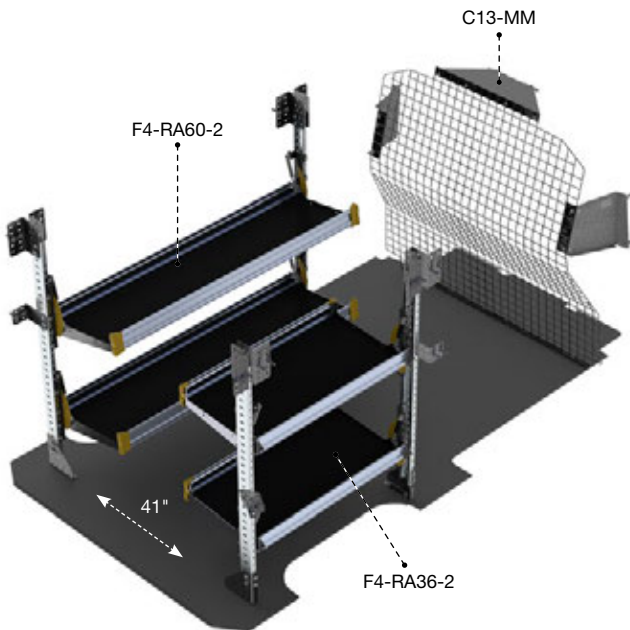
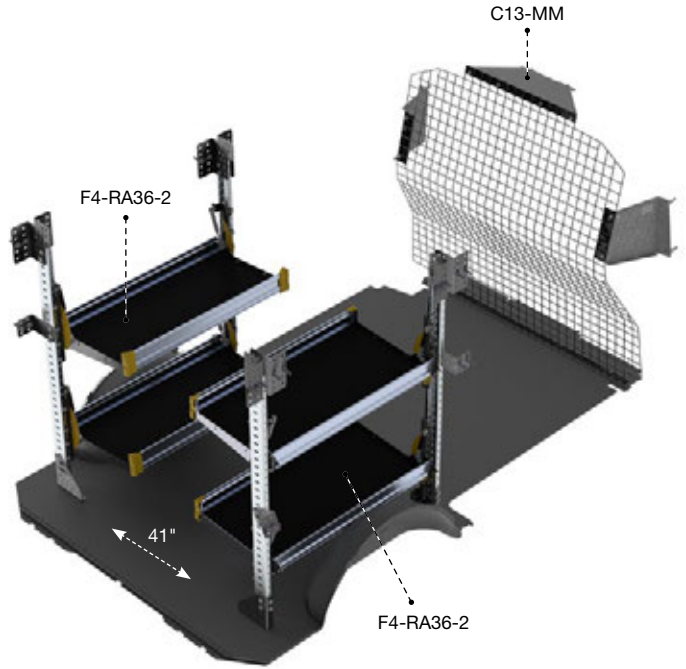

MML-19
 126" OR 135" WHEELBASE
 > Standard Roof



Qty	Part #	Description
1	C13-MM	Wire mesh partition
1	F4-RA60-2	Fold-away unit, 2 levels, 22" D x 60" W x 47" H
1	F4-RA36-2	Fold-away unit, 2 levels, 22" D x 36" W x 47" H

The Deluxe package is designed to fit in a Metris with a single sliding door.



VISIT OUR WEBSITE FOR
OUR FULL-LINE OF PARTITIONS

MML-19

DELIVERY

YOUR PERSONAL **FLEX SPACE**

Our fold-away shelves are designed to give you the ultimate in cargo flexibility

- Flexible
- Easy to use
- Tough



THE BENEFITS OF **ALUMINUM**

Weight saving equipment reduces total cost of ownership



Optimize fuel economy by decreasing overall van mass



Reduce vehicle maintenance and repairs caused by weight overload



Increase payload without sacrificing quality – it's a benefit offered only by aluminum

**Did you know that for every 100 lbs reduction,
you increase fuel economy by 1%?**

www.fueleconomy.gov

**Ranger Design is the leader for
aluminum upfits in North America**



MMR-27

126" OR 135" WHEELBASE
 > Standard Roof



Qty	Part #	Description
1	3320-MM	Max view contoured safety partition
1	5011	Partslider 36" D
1	5021	Tool drawer 36" D x 14" W x 16" H
1	5051	Top edge
2	62-U5070	Partskeeper carry case with holder
1	6070	6" Hook, 3" opening, painted
3	62-U1112	14" Deep plastic bin
6	62-U1114	14" Deep plastic bin
1	62-UDR12	Set of 5 dividers for a 12" shelf
1	62-UDR14	Set of 5 dividers for a 14" shelf
1	77-U1036	Adjustable shelving door unit - 33" W - for 36" & 72" shelves
2	N4-RA36-3	Aluminum shelving unit for low roof van 14" D x 36" W x 44.5" H

The Base package is designed to fit in a Metris with dual sliding doors.

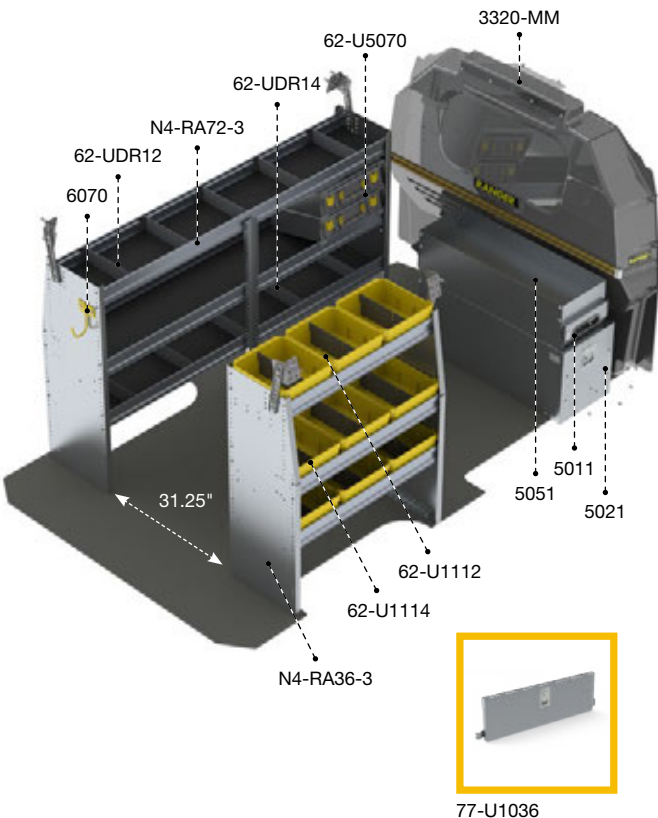
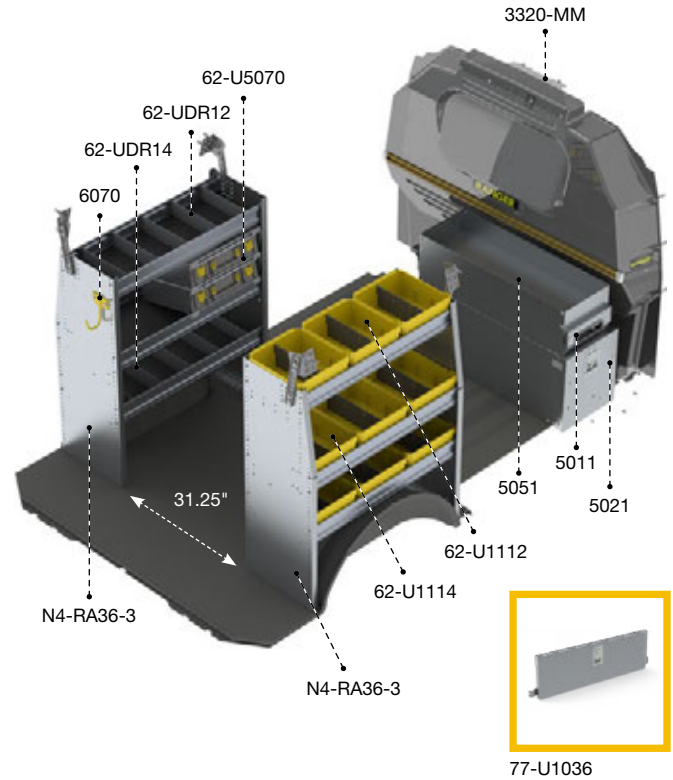

MML-27

126" OR 135" WHEELBASE
 > Standard Roof



Qty	Part #	Description
1	3320-MM	Max view contoured safety partition
1	5011	Partslider 36" D
1	5021	Tool drawer 36" D x 14" W x 16" H
1	5051	Top edge
2	62-U5070	Partskeeper carry case with holder
1	6070	6" Hook, 3" opening, painted
3	62-U1112	12" Deep plastic bin
6	62-U1114	14" Deep plastic bin
1	62-UDR12	Set of 5 dividers for a 12" shelf
1	62-UDR14	Set of 5 dividers for a 14" shelf
1	77-U1036	Adjustable shelving door unit - 33" W - for 36" & 72" shelves
1	N4-RA36-3	Aluminum shelving unit for low roof van 14" D x 36" W x 44.5" H
1	N4-RA72-3	Aluminum shelving unit for low roof van 14" D x 72" W x 44.5" H

The Deluxe package is designed to fit in a Metris with a single sliding door.

DRAWERS

DRAWERS

Increase storage and organization with Ranger Design's line of drawer units



5051
Top Edge for drawers



5011
Partslider Organizer 36"D x 12"W x 6"H



5021
Tool Drawer 36"D x 14"W x 16"H



5026
Jumbo tool drawer 36"D x 16"W x 19"H

TOOL DRAWER TIP
Stack these drawers for
the ultimate efficiency



STORAGE UNITS

Ergonomic storage solutions for the cargo space in your vehicle.



62-U5079
Partskeeper carry case



CAN BE INSTALLED EITHER WAY



62-U5070
Partskeeper carry case with holder, universal



62-U5074
Partskeeper floor mount cabinet with 4 carry cases, universal



N4-PS20-8
Partskeeper cabinet with 8 carry cases



N4-LS16-1
Locker with top shelf, universal (Comes with 2 hooks)



S2-WA48-0
Workbench, with hardwood top, one end panel, Universal (drawer cabinet not included)



5067-6
Workbench with hardwood top, one end panel (Drawer cabinet not included)



S2-WA48-1
Workbench, aluminum with hardwood top, 1 shelf tray, Universal

ACCESSORIES

Choose the finishing details to tailor the upfit to your specific needs.



CARGO HOLDERS

Increase organization by giving a specific spot to store your equipment. Instead of being loose on the floor, your reels, cans etc. can be secured within easy reach from the door.



6010
Two level adjustable bottle holder



6057
Can holder



6068
Hard hat holder, painted wire



7124
Reel holder with two 5/8" diameter rods

STORAGE HOOKS

Keep frequently used items such as hats, vests and extension cords hanging within easy reach while on the road.



6070
6" Hook, 3" opening, painted



6073
Large aluminum movable hook, 6.5" opening

FLETTNER VENT

Guard yourself against any smells or vapors that may build up in the cargo area. The Flettner vent is a simple way to stay healthy while on the job.

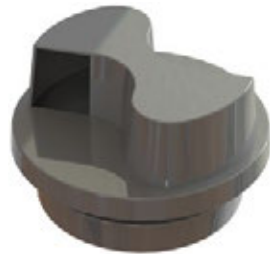

6050
Flettner vent, rotary design

SEAT COVERS

Keep your cab looking just like new with tight custom fit seat covers. The water & stain resistant fabric keeps your seats looking clean and increases resale value.



6258
Seat covers

LED LIGHTING

Keeps the cargo space bright, making visibility easy, no matter what time of day or night. Eliminate any chance of injury when searching through your tools in the dark.



6092-42
Universal LED light kit for trucks and vans (12V DC / 1200 Lm / 10W)

WIRE GRILLS

Protect your van against theft and prevent damage to the van during loading or unloading, with Ranger Design's window grills.

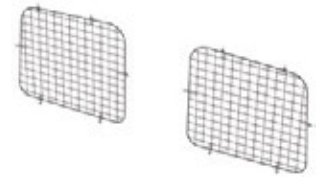

6126
Set of 2 rear window grills

GRAB HANDLE

It is always useful to have something to hold onto when climbing into your van. Grab handles can also be used to tie down extra cargo during transport.



6093-27
Large grab handle



6093
Grab handle

**STAY SAFE
WITH RANGER
DESIGN'S
COMMERCIAL
VEHICLE
ACCESSORIES**

LADDER RACKS



Cargo + rack

Aluminum			
1506-MM	126"	Standard	—
1506-M	135"	Standard	—



Combination Rack – 2 bar

Aluminum			
1625-MM	126", 135"	Standard	28 ft



Cargo rack

Aluminum			
1605-MM	126", 135"	Standard	—



Double clamp ladder rack

Aluminum			
1630-MM	126", 135"	Standard	28 ft
1630-MM3 – 3 Bar	126", 135"	Standard	28 ft



Cargo rack – 3 bar

Aluminum			
1605-MM3	126", 135"	Standard	—



Max rack low roof

Aluminum			
1840-MM – Single	126", 135"	Standard	28 ft
1850-MM – Double	126", 135"	Standard	28 ft

VISIT OUR WEBSITE FOR OUR FULL-LINE OF LADDER RACKS

Models may vary to those shown. Please visit our website for all images.

Turn-Key Fleet Services



A Leader in Fleet Upfitting in North America

Our Proven Process to Deliver a Better Experience for Fleets:

1. Analysis

- › Cargo Needs Analysis
- › Custom 3D CAD Layouts
- › Hands-on Equipment Demo

2. Testing

- › Test Fitting
- › Pilot Build and Review
- › Package optimization based on technician feedback

3. Delivery

- › Delivery, production, installation planning and scheduling
- › Vehicle Status Tracking

4. Service

- › Dedicated Fleet Account Management Team
- › Ranger Design Distributor Service Support Network
- › Live Customer Service

Ship Through or Local Installation Across the continent for all Types of Cargo Vans

THE PERFECT FIT
FOR YOUR
TOUGHEST JOBS

When you want the **perfect upfit solution** for your work vehicle, turn to Ranger Design. **Tested for toughness**, Ranger Design's shelving and upfits will take whatever abuse you can dish out. Their **unsurpassed craftsmanship**, combined with ideal fit and finish, provide **a quiet ride with no rattles**.



RANGERTM
DESIGN

CUSTOMER SERVICE

cs@rangerdesign.com
1-800-565-5321

rangerdesign.com

