

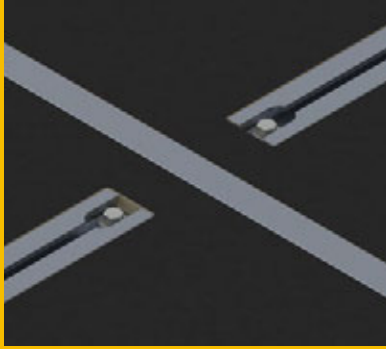

VAN UPFIT PREP

Preparing for the installation of your upfit made easier



EFFICIENCY

Incorporated mounting tracks for most Ranger Design products.



SAFETY

Extruded aluminum joints where floor pieces meet.

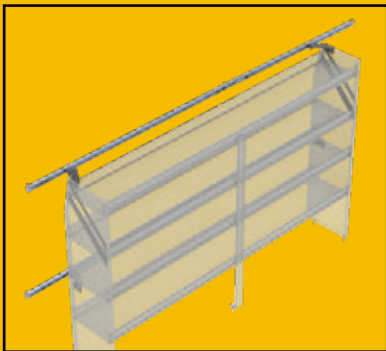

QUICK INSTALL

Our install kits simplify your installation.

VAN UPFIT PREP

VAN FLOORS

CHEVROLET EXPRESSP. 24
 FORD TRANSIT P. 24
 FORD TRANSIT CONNECT P. 25
 GMC SAVANA P. 25
 MERCEDES-BENZ SPRINTER P. 25
 NISSAN NV P. 26
 NISSAN NV200 P. 26
 RAM PROMASTER P. 26
 RAM PROMASTER CITY P. 26

INSTALL KITS

DRIVERP. 28
 PASSENGER P. 29

VAN FLOORS

- › Easy to install with integrated mounting tracks
- › Compatible with Ranger Design’s shelving packages
- › Custom fit for almost all vans
- › Includes aluminum sills at the side and rear doors
- › No thermal expansion
- › Much safer due to load distribution
- › Quieter ride – reduces noise for the cargo area
- › 3 year warranty



VAN UPFIT PREP – FLOORS

VAN UPFIT PREP

IT'S MORE THAN A FLOOR!



CHEVROLET EXPRESS

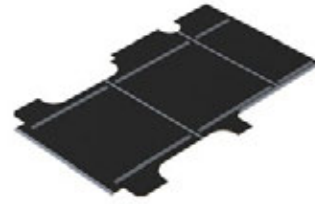

6540-GSR

Chevrolet Express Floor

Marine-Grade Plywood

135"

74 lbs

1 hr

Yes

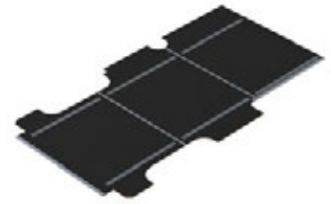

6540-GSX

Chevrolet Express Floor

Marine-Grade Plywood

155" Ext.

89 lbs

1 hr

Yes



FORD TRANSIT

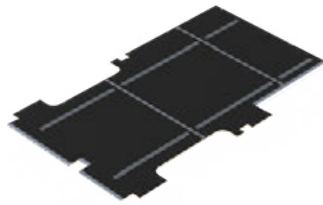

6540-FTS

Ford Transit Floor

Marine-Grade Plywood

130"

70 lbs

1 hr

Yes

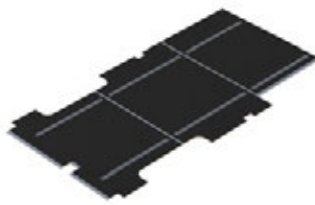

6540-FTL

Ford Transit Floor

Marine-Grade Plywood

148"

88 lbs

1 hr

Yes

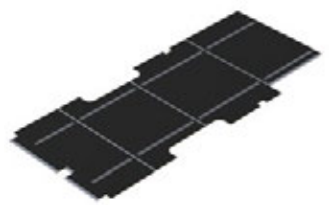

6540-FTX

Ford Transit Floor

Marine-Grade Plywood

148" Ext.

109 lbs

1.3 hrs

Yes

Not designed for DRW (Dual Rear Wheel)





FORD
TRANSIT CONNECT ▶



6540-FCS
Ford Transit Connect Floor

Marine-Grade Plywood	
105"	
33 lbs	
0.7 hr	
Yes	



6540-FCL
Ford Transit Connect Floor

Marine-Grade Plywood	
120.5"	
42 lbs	
0.7 hr	
Yes	

Impact and puncture resistant floors preserve the cargo van interior

Incorporated mounting tracks means easy install for most Ranger Design products.



GMC
SAVANA ▶

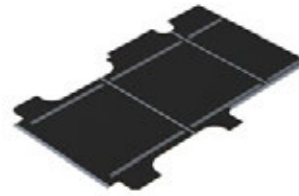

6540-GSR
GMC Savana Floor

Marine-Grade Plywood	
135"	
74 lbs	
1 hr	
Yes	

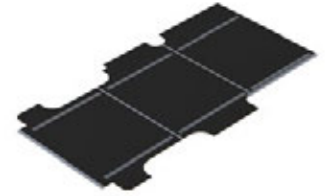

6540-GSX
GMC Savana Floor

Marine-Grade Plywood	
155"	
89 lbs	
1 hr	
Yes	



MERCEDES-BENZ
SPRINTER ▶

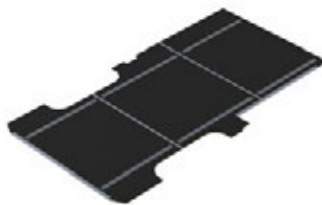

6540-DR
Mercedes-Benz Sprinter Floor

Marine-Grade Plywood	
144"	
86 lbs	
1 hr	
Yes	

Not designed for DRW (Dual Rear Wheel)



PROTECTION
Rigid floor covering protects cargo van floors from impact damage and scratches.

VAN UPFIT PREP – FLOORS

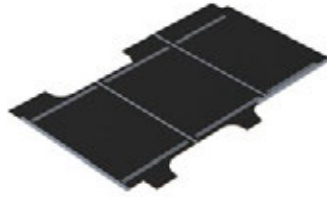

6540-NV

Nissan NV Floor

Marine-Grade Plywood

146"

73 lbs

1 hr

Yes

NISSAN
NV

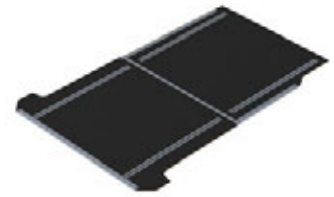

6540-NS

Nissan NV200 Floor

Marine-Grade Plywood

115"

43 lbs

1 hr

Yes

NISSAN
NV200

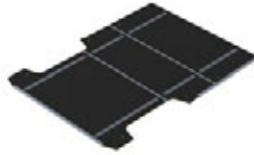

6540-PS

RAM ProMaster Floor

Marine-Grade Plywood

118"

71 lbs

1 hr

Yes

RAM
PROMASTER

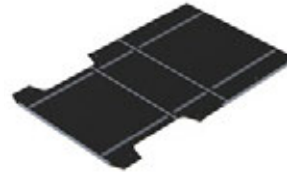

6540-PM

RAM ProMaster Floor

Marine-Grade Plywood

136"

83 lbs

1 hr

Yes

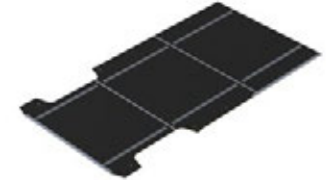

6540-PL

RAM ProMaster Floor

Marine-Grade Plywood

159"

100 lbs

1 hr

Yes

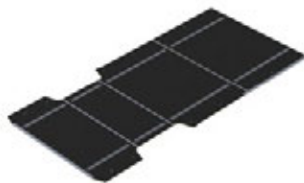

6540-PX

RAM ProMaster Floor

Marine-Grade Plywood

159" Ext.

112 lbs

1.3 hrs

Yes



RAM
PROMASTER CITY

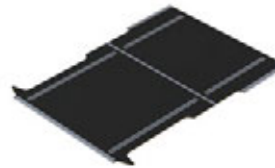

6540-PC

RAM ProMaster City Floor

Marine-Grade Plywood

122"

46 lbs

0.7 hr

Yes

The 6540-PC does not fit the 2020 and 2021 ProMaster City



Safer due to the integrated track, improved load distribution and noise reduction.

IT'S MORE THAN A FLOOR

Ranger Design's unique flooring system with integrated aluminum mounting tracks provides a flush surface, making it easy to install a variety of Ranger Design shelving, equipment and accessories.

Ranger Design's custom-fit rigid flooring system is available for most service vans. Designed to provide added safety and a quieter ride. The floors are also impact and puncture resistant giving your van a professional look. Unique benefits of these flooring products include:

- **Economical** – because the flooring has integrated mounting tracks for the price of a regular floor
- **Safer** – due to the integrated track, improved load distribution and noise reduction
- **Improved van resale value** – durable professional looking and protects the vehicle
- **Efficient** – 3 panel floor installed in 45 minutes by one person and easy to maintain



VAN UPFIT PREP – INSTALL KITS

INSTALL KITS



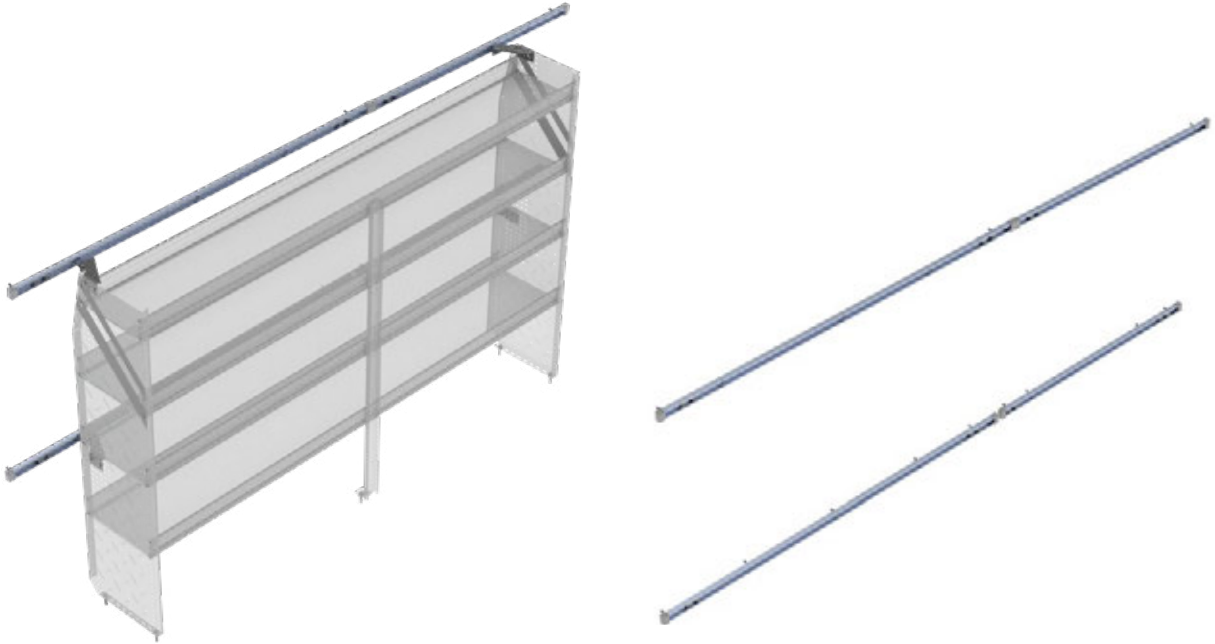

VAN UPFIT PREP



Install kits are optional and sold without the shelving unit

6550-FTL SHOWN HERE.

Install Kit – Driver

PART	VEHICLE		DESCRIPTION			
6550-FTL	FORD TRANSIT	148"	Shelving install kit, driver side	13 lbs	0.3 hr	Yes
6550-FTS	FORD TRANSIT	130"	Shelving install kit, driver side	12 lbs	0.3 hr	Yes
6550-FTX	FORD TRANSIT	148" Ext	Shelving install kit, driver side	16 lbs	0.3 hr	Yes
6550-NVL	NISSAN NV	Universal	Install track kit, driver side	5.2 lbs	–	Yes
6550-PC	RAM PROMASTER CITY	Universal	Install track kit, driver side, passenger side	4.9 lbs	–	Yes
6550-PL	RAM PROMASTER	159"	Install track kit, driver side	13 lbs	–	Yes
6550-PM	RAM PROMASTER	136"	Install track kit, driver side	11 lbs	–	Yes
6550-PS	RAM PROMASTER	118"	Install track kit, driver side	8.9 lbs	–	Yes
6550-PX	RAM PROMASTER	159" Ext	Install track kit, driver side	14 lbs	–	Yes





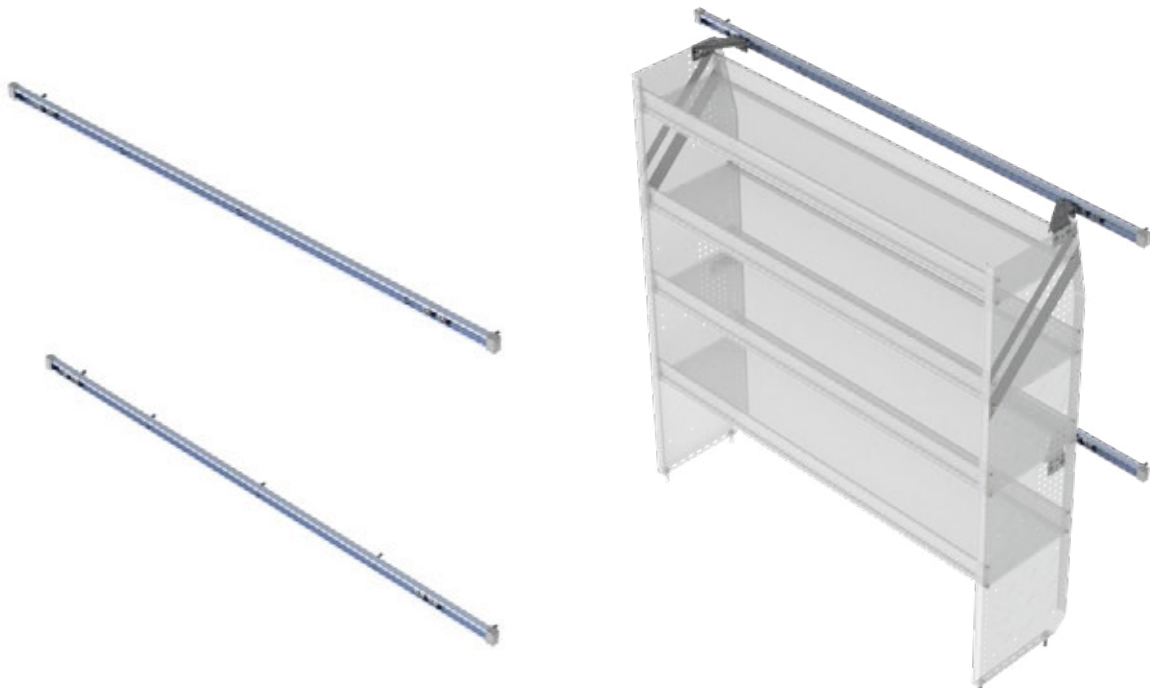

VAN UPFIT PREP – INSTALL KITS



6555-FTL SHOWN HERE.

Install kits are optional and sold without the shelving unit

Install Kit – Passenger						
PART	VEHICLE	 Wheelbase	DESCRIPTION	 Weight	 Estimated Install Time	 Quickship
6555-FTL	FORD TRANSIT	148"	Shelving install kit, passenger side	7.7 lbs	0.4 hr	Yes
6555-FTS	FORD TRANSIT	130"	Shelving install kit, passenger side	6 lbs	0.4 hr	Yes
6555-FTX	FORD TRANSIT	148" Ext	Shelving install kit, passenger side	11 lbs	0.4 hr	Yes
6555-NVL	NISSAN NV	Universal	Shelving install kit, passenger side	2.7 lbs	–	Yes
6555-PL	RAM PROMASTER	159"	Shelving install kit, passenger side	7.5 lbs	–	Yes
6554-PM	RAM PROMASTER	136"	Shelving install kit, passenger side	5.5 lbs	–	Yes
6555-PS	RAM PROMASTER	118"	Shelving install kit, passenger side	4.5 lbs	–	Yes
6555-PX	RAM PROMASTER	159" Ext	Shelving install kit, passenger side	8.6 lbs	–	Yes

