

BOX TRUCK

STEP VAN & TRAILER



UPFIT GUIDE



**THE PERFECT FIT
FOR YOUR
TOUGHEST JOBS**

HELPING MOBILE TECHNICIANS WORK MORE EFFECTIVELY BY PROVIDING ORGANIZED STORAGE SOLUTIONS

AT RANGER DESIGN, WE BELIEVE MORE IS POSSIBLE.

We believe work vehicles and the technicians that drive them can become more organized, more efficient, more productive and more profitable. At Ranger Design we're committed to bringing you the products and services that make that possible.

More means helping you choose the right work van for your application, as well as giving you engineering support and expert advice to help design the most efficient work space in your new vehicle.

More also means getting that new van outfitted and on the road faster, so you can start using it for the reason you bought it.

We're committed to bringing you more, because we believe more is possible.



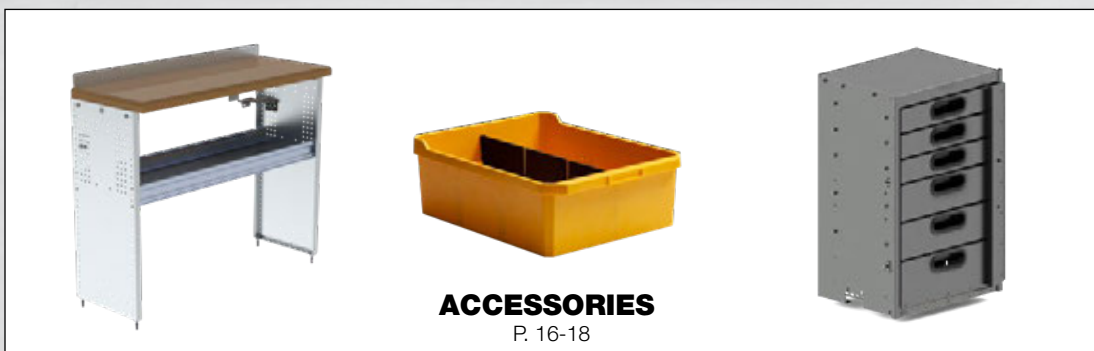
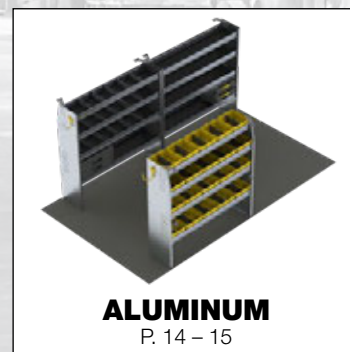
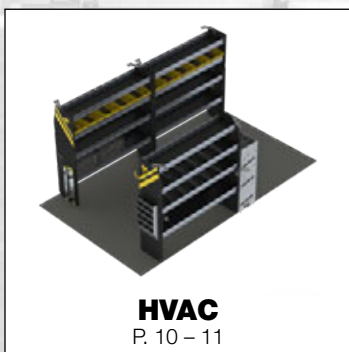
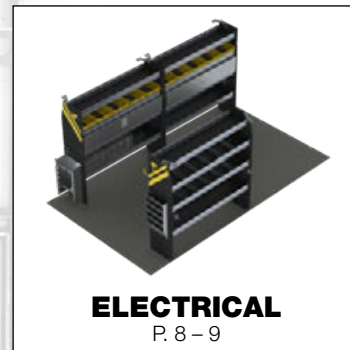

Large Distributor Network Across the Continent

Buy Ranger Design Quickship service is available through your local distributor. rangerdesign.com/find-distributor

Lead Time Quickship orders placed with Ranger Design before 1PM EST, will ship from our factory in the next business day.



All products shown in this upfit guide are available on Quickship

BTS-10

SHORT 10+

Qty	Part #	Description
1	6070	6" Hook, 3" opening, painted
1	N5-RS60-4	Steel shelving unit for high roof van, 14" D x 60" W x 62" H
1	N5-RS96-4	Steel shelving unit for high roof van, 14" D x 96" W x 62" H

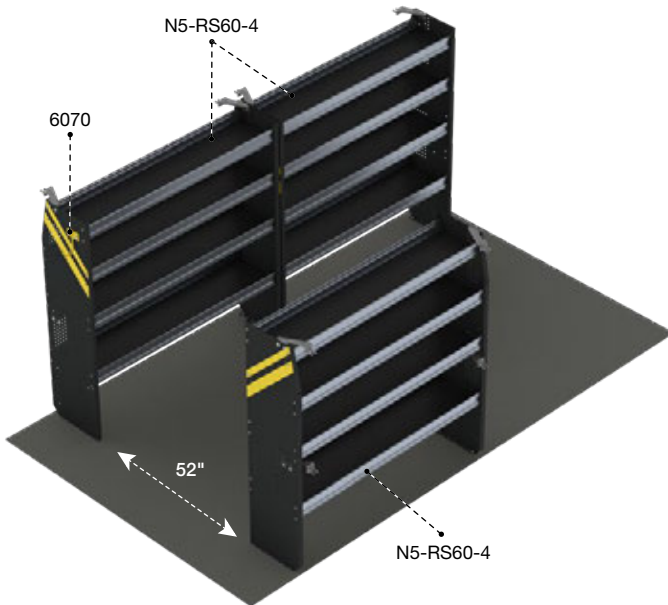
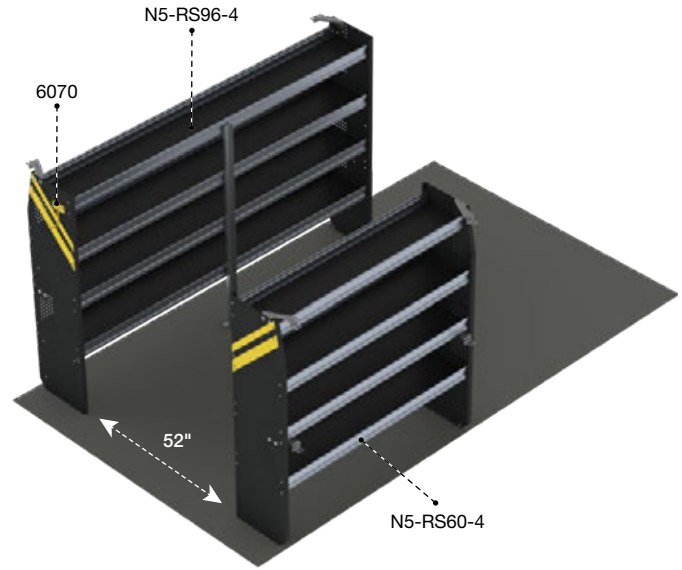

BTL-10

LONG 14+

Qty	Part #	Description
1	6070	6" Hook, 3" opening, painted
3	N5-RS60-4	Steel shelving unit for high roof van, 14" D x 60" W x 62" H

Aisle space calculated in this catalog is based on an 84" wide box.



BTL-10

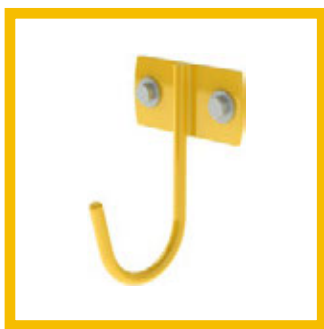

6070

6" Hook,
3" opening,
painted



BTS-16

SHORT 10+

Qty	Part #	Description
1	6070	6" Hook, 3" opening, painted
1	6072	8" Swivel hook, 4" opening, painted
5	62-U1114	14" Deep plastic bin
2	62-UDR14	Set of 5 dividers for a 14" shelf
1	N5-RS60-4	Steel shelving unit for high roof van, 14" D x 60" W x 62" H
1	N5-RS96-4	Steel shelving unit for high roof van, 14" D x 96" W x 62" H
2	X50-B	Compact 2-drawer unit

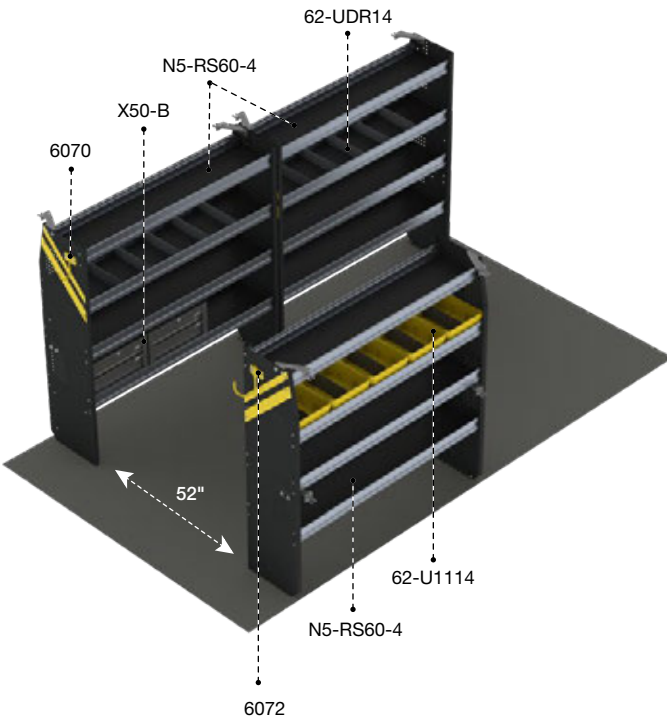
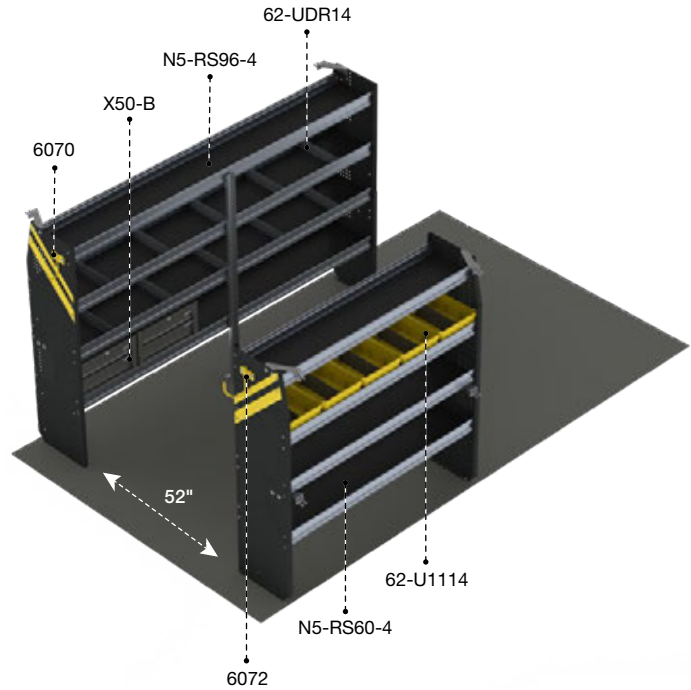

BTL-16

LONG 14+

Qty	Part #	Description
1	6070	6" Hook, 3" opening, painted
1	6072	8" Swivel hook, 4" opening, painted
5	62-U1114	14" Deep plastic bin
2	62-UDR14	Set of 5 dividers for a 14" shelf
3	N5-RS60-4	Steel shelving unit for high roof van, 14" D x 60" W x 62" H
2	X50-B	Compact 2-drawer unit

Aisle space calculated in this catalog is based on an 84" wide box.



BTL-16



6072

8" Swivel hook,
4" opening, painted

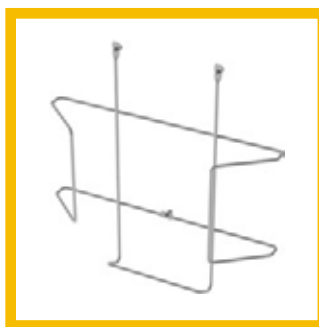

6068

Hard hat holder,
painted wire



6050

Flettner vent, rotary design

BTS-11

SHORT 10+

Qty	Part #	Description
1	6063	Paper holder, extra deep, 5 slots
1	6070	6" Hook, 3" opening, painted
1	6072	8" Swivel hook, 4" opening, painted
8	62-U1114	14" Deep plastic bin
2	62-UDR14	Set of 5 dividers for a 14" shelf
1	7124	Reel holder with two 5/8" diameter rods
2	77-U1048	Adjustable shelving door unit - 45" W - for 48" & 96" shelves
1	N5-RS60-4	Steel shelving unit for high roof van, 14" D x 60" W x 62" H
1	N5-RS96-4	Steel shelving unit for high roof van, 14" D x 96" W x 62" H
1	X50-B	Compact 2-drawer unit
1	X50-C	Compact 3-drawer unit

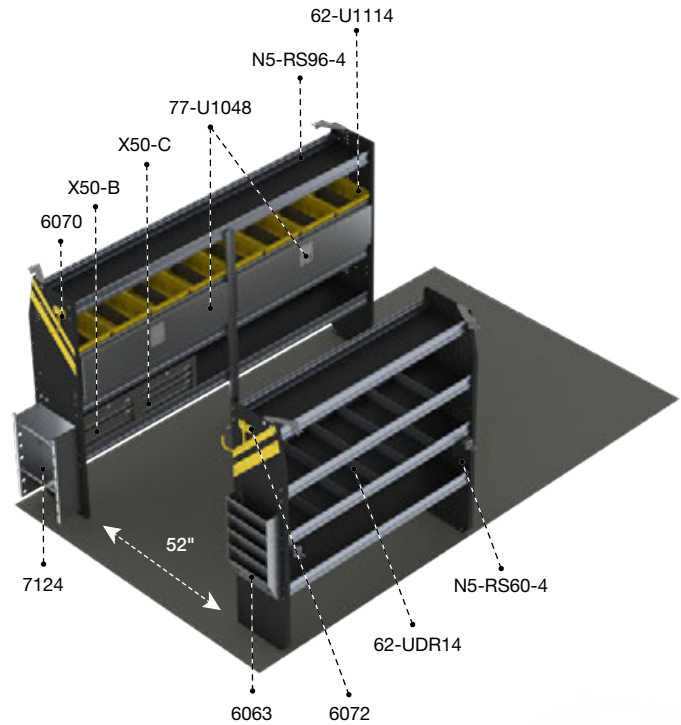

ELECTRICAL

BTL-11

LONG 14+

Qty	Part #	Description
1	6063	Paper holder, extra deep, 5 slots
1	6070	6" Hook, 3" opening, painted
1	6072	8" Swivel hook, 4" opening, painted
10	62-U1114	14" Deep plastic bin
2	62-UDR14	Set of 5 dividers for a 14" shelf
1	7124	Reel holder with two 5/8" diameter rods
2	77-U1060	Adjustable shelving door unit - 57" W - for 60" shelves
3	N5-RS60-4	Steel shelving unit for high roof van, 14" D x 60" W x 62" H
1	X50-B	Compact 2-drawer unit
1	X50-C	Compact 3-drawer unit

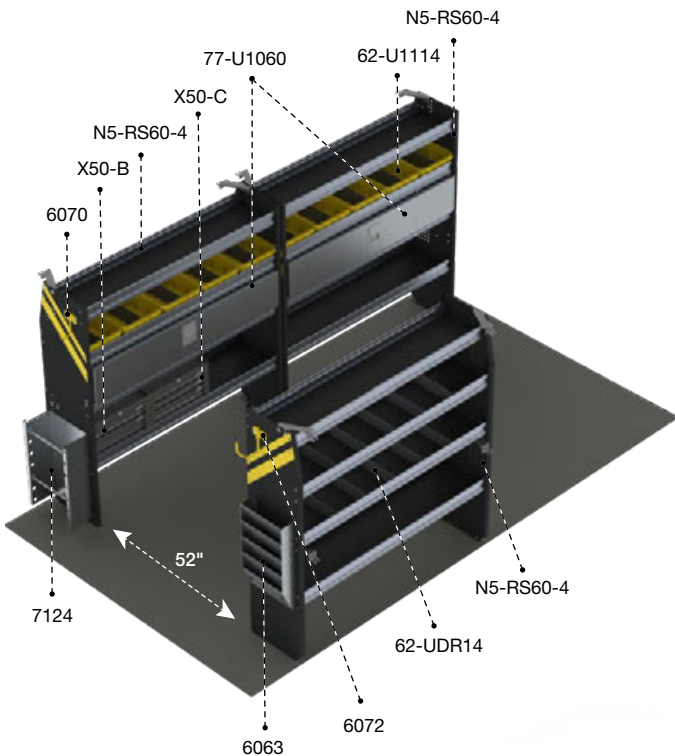

Aisle space calculated in this catalog is based on an 84" wide box.



BTL-11



**62-U1110, 62-U1112,
62-U1114**

Plastic bins with a center divider
Available in 10", 12" or 14" depths



62-U1212

2 Cross dividers for bin
Fits all size bins



77-U1048

Adjustable shelving door unit
45" wide for a 48" or 96" shelf

BTS-12

SHORT 10+

Qty	Part #	Description
1	6008	3 Tier refrigerant rack for large bottles
1	6063	Paper holder, extra deep, 5 slots
1	6070	6" Hook, 3" opening, painted
1	6072	8" Swivel hook, 4" opening, painted
1	6088	Large aluminum bottle holder, with two black nylon straps
8	62-U1114	14" Deep plastic bin
2	62-UDR14	Set of 5 dividers for a 14" shelf
1	77-U1060	Adjustable shelving door unit - 57" W - for 60" shelves
1	N5-RS60-4	Steel shelving unit for high roof van, 14" D x 60" W x 62" H
1	N5-RS96-4	Steel shelving unit for high roof van, 14" D x 96" W x 62" H
2	X50-B	Compact 2-drawer unit

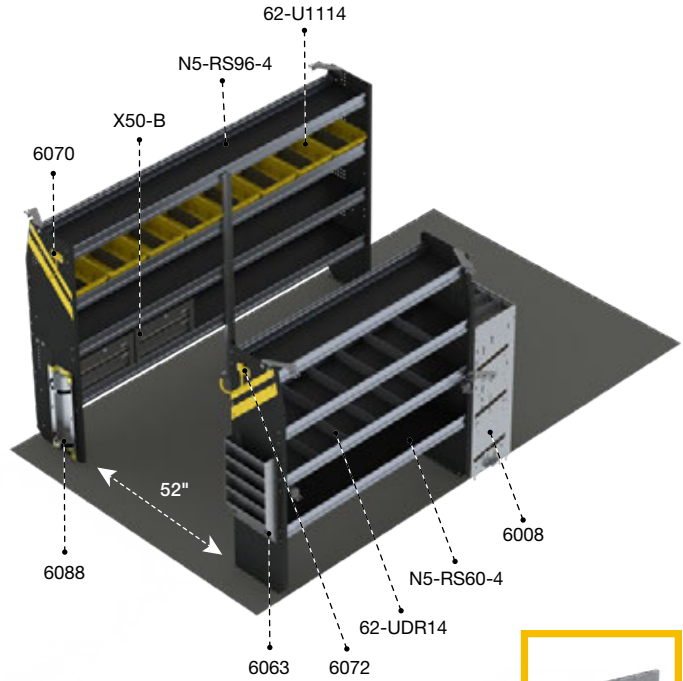

77-U1060

Packages BTS-12 and BTL-12 are designed for boxes with side access. For boxes with no side access, it is recommended to reposition the 6008 bottle rack.

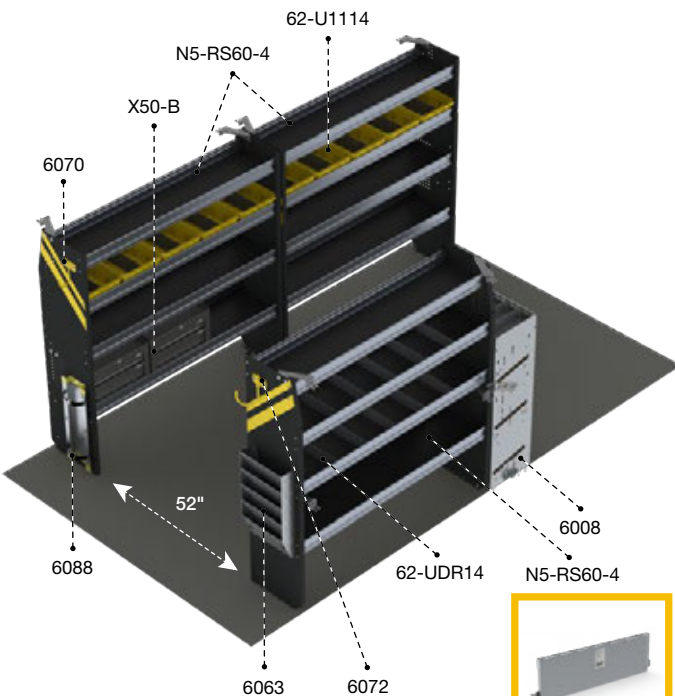

77-U1060

BTL-12

LONG 14+

Qty	Part #	Description
1	6008	3 Tier refrigerant rack for large bottles
1	6063	Paper holder, extra deep, 5 slots
1	6070	6" Hook, 3" opening, painted
1	6072	8" Swivel hook, 4" opening, painted
1	6088	Large aluminum bottle holder, with two black nylon straps
10	62-U1114	14" Deep plastic bin
2	62-UDR14	Set of 5 dividers for a 14" shelf
1	77-U1060	Adjustable shelving door unit - 57" W - for 60" shelves
3	N5-RS60-4	Steel shelving unit for high roof van, 14" D x 60" W x 62" H
2	X50-B	Compact 2-drawer unit

Aisle space calculated in this catalog is based on an 84" wide box.



BTL-12



**62-UDR10, 62-UDR12,
62-UDR14**

Set of 5 dividers for a
10", 12" or 14" shelf

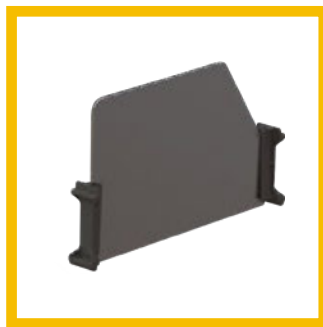

62-UDH14

Set of 5 high dividers
for a 14" shelf



6088

Large aluminum bottle holder,
with two black nylon straps



6008

3 Tier refrigerant
rack for large bottles

FOR MORE ACCESSORIES, SEE PAGE 17.

BTS-19

SHORT 10+

Qty	Part #	Description
1	84-U0063	Post assembly for fold-away shelving 63"
2	84-U2036	Fold-away shelf tray, 20" D x 36" W
2	F5-RA60-2	Fold-away unit, 2 levels, 25" D x 60" W x 63" H

Aisle space calculated for this package is based on an 84" wide box.

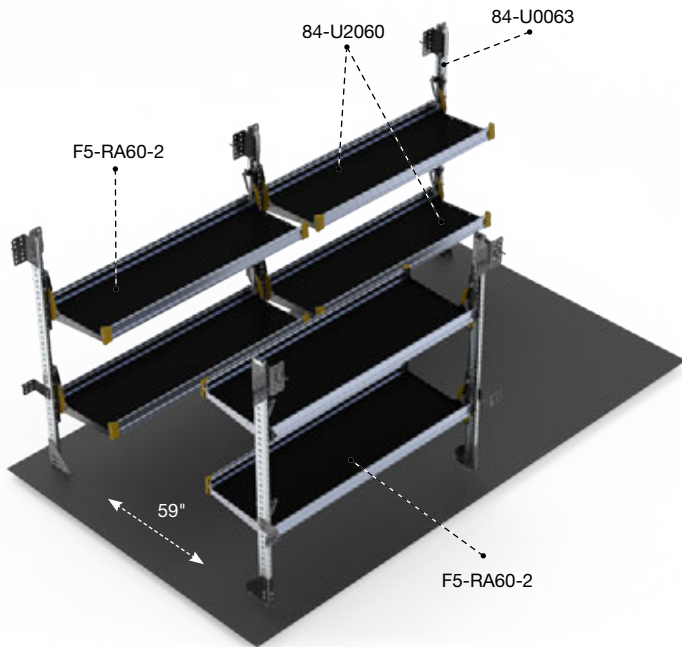
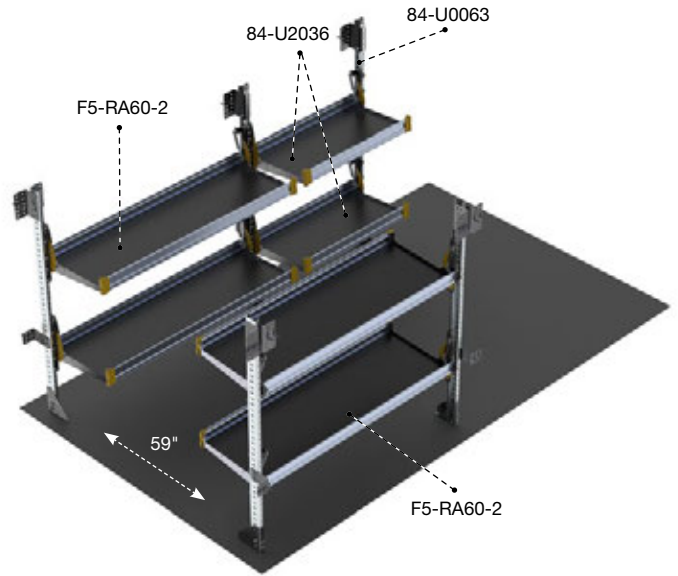

BTL-19

LONG 14+

Qty	Part #	Description
1	84-U0063	Post assembly for fold-away shelving 63"
2	84-U2060	Fold-away shelf tray, 60" W x 20" D
2	F5-RA60-2	Fold-away unit, 2 levels, 25" D x 60" W x 63" H

Aisle space calculated for this package is based on an 84" wide box.

Aisle space calculated in this catalog is based on an 84" wide box.

**BTL-19**

YOUR PERSONAL **FLEX SPACE**

Our fold-away shelves are designed to give you the ultimate in cargo flexibility

- Flexible
- Easy to use
- Tough



THE BENEFITS OF **ALUMINUM**

Weight saving equipment reduces total cost of ownership



Optimize fuel economy by decreasing overall van mass



Reduce vehicle maintenance and repairs caused by weight overload



Increase payload without sacrificing quality – it's a benefit offered only by aluminum

**Did you know that for every 100 lbs reduction,
you increase fuel economy by 1%?**

www.fueleconomy.gov

**Ranger Design is the leader for
aluminum upfits in North America**



BTS-27

SHORT 10+

Qty	Part #	Description
1	5069-2	2 Drawer cabinet
2	62-U5070	Partskeeper carry case with holder
1	6070	6" Hook, 3" opening, painted
1	6072	8" Swivel hook, 4" opening, painted
5	62-U1112	12" Deep plastic bin
15	62-U1114	14" Deep plastic bin
1	62-UDR12	Set of 5 dividers for a 12" shelf
2	62-UDR14	Set of 5 dividers for a 14" shelf
1	77-U1060	Adjustable shelving door unit - 57" W - for 60" shelves
1	N5-RA60-4	Aluminum shelving unit high roof van, 60", 14"D x 60" W x 62"H
1	N5-RA96-4	Aluminum shelving unit high roof van, 96", 14"D x 96" W x 62"H

Aisle space calculated for this package is based on an 84" wide box.

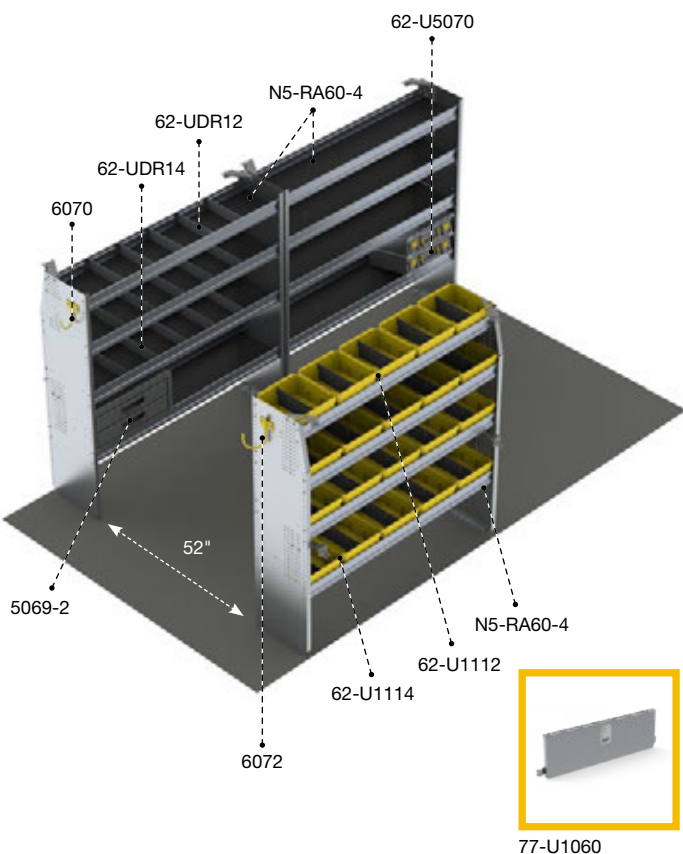
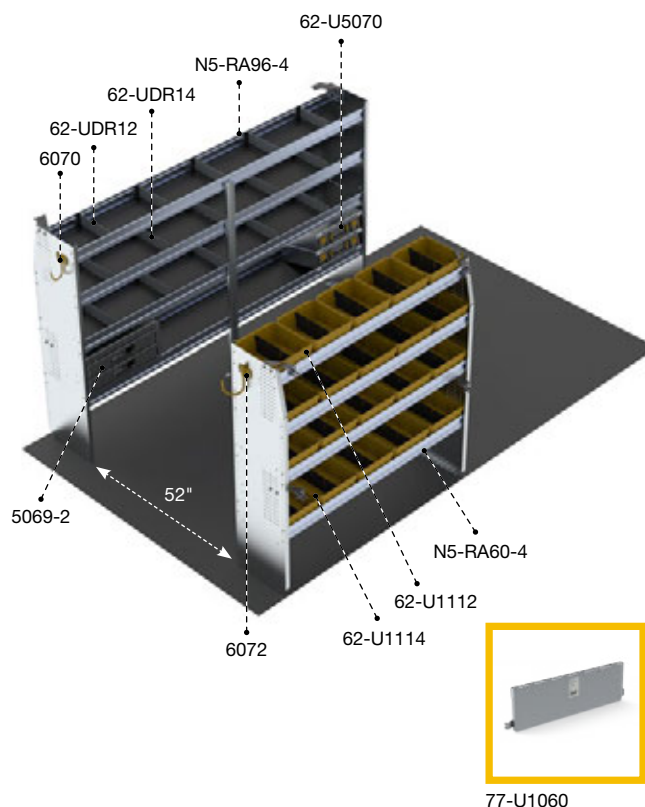

BTL-27

LONG 14+

Qty	Part #	Description
1	5069-2	2 Drawer cabinet
2	5070	Partskeeper carry case with holder
1	6070	6" Hook, 3" opening, painted
1	6072	8" Swivel hook, 4" opening, painted
5	62-U1112	12" Deep plastic bin
15	62-U1114	14" Deep plastic bin
1	62-UDR12	Set of 5 dividers for a 12" shelf
2	62-UDR14	Set of 5 dividers for a 14" shelf
1	77-U1060	Adjustable shelving door unit - 57" W - for 60" shelves
3	N5-RA60-4	Aluminum shelving unit high roof van, 60", 14"D x 60" W x 62"H

Aisle space calculated for this package is based on an 84" wide box.w

Aisle space calculated in this catalog is based on an 84" wide box.

STORAGE UNITS

STORAGE UNITS

Ergonomic storage solutions for the cargo space in your vehicle.



62-U5079

Partskeeper carry case



CAN BE INSTALLED EITHER WAY



62-U5070

Partskeeper carry case with holder, universal



62-U5074

Partskeeper floor mount cabinet with 4 carry cases, universal



N5-PS20-8

Partskeeper cabinet with 8 carry cases & 2 shelves, universal

STORAGE UNITS



N5-LS16-1

Locker with top shelf, 16" D x 16" W x 63" H



S3-WA48-0

Workbench, with hardwood top, one end panel, Universal (drawer cabinet not included)



5060-5



S3-WA48-1

Workbench, aluminum with hardwood top, 1 shelf tray, Universal

ACCESSORIES

Choose the finishing details to tailor the upfit to your specific needs.



CARGO HOLDERS

Increase organization by giving a specific spot to store your equipment. Instead of being loose on the floor, your reels, cans etc. can be secured within easy reach from the door.



6010
Two level adjustable bottle holder



6057
Can holder



6068
Hard hat holder, painted wire



7124
Reel holder with two 5/8" diameter rods

STORAGE HOOKS

Keep frequently used items such as hats, vests and extension cords hanging within easy reach while on the road.



6070
6" Hook, 3" opening, painted



6073
Large aluminum movable hook, 6.5" opening

PAPER HOLDERS

Keep your paperwork and files all together and in a safe place where they won't get ripped or crumpled.



6063

Paper Holder, extra deep,
5 slots



6067

Paper Holder, regular
depth, 2 slots



6069

Paper Holder, regular depth,
5 slots

LED LIGHTING

Keeps the cargo space bright, making visibility easy, no matter what time of day or night. Eliminate any chance of injury when searching through your tools in the dark.



6092-42

Universal LED light kit for
trucks and vans (12V DC /
1200 Lm / 10W)

GRAB HANDLE

It is always useful to have something to hold onto when climbing into your van. Grab handles can also be used to tie down extra cargo during transport.



6093-27

Large grab handle

STAY SAFE WITH RANGER DESIGN'S COMMERCIAL VEHICLE ACCESSORIES

Turn-Key Fleet Services



A Leader in Fleet Upfitting in North America

Our Proven Process to Deliver a Better Experience for Fleets:

1. Analysis

- › Cargo Needs Analysis
- › Custom 3D CAD Layouts
- › Hands-on Equipment Demo

2. Testing

- › Test Fitting
- › Pilot Build and Review
- › Package optimization based on technician feedback

3. Delivery

- › Delivery, production, installation planning and scheduling
- › Vehicle Status Tracking

4. Service

- › Dedicated Fleet Account Management Team
- › Ranger Design Distributor Service Support Network
- › Live Customer Service

Ship Through or Local Installation Across the continent for all Types of Cargo Vans

THE PERFECT FIT
FOR YOUR
TOUGHEST JOBS

When you want the **perfect upfit solution** for your work vehicle, turn to Ranger Design. **Tested for toughness**, Ranger Design's shelving and upfits will take whatever abuse you can dish out. Their **unsurpassed craftsmanship**, combined with ideal fit and finish, provide **a quiet ride with no rattles**.



CUSTOMER SERVICE

cs@rangerdesign.com

1-800-565-5321

rangerdesign.com

