

# INTERIOR PROTECTION FOR CARGO VANS

**LEGEND**  
**FLEET SOLUTIONS**  
ISO 9001:2015  
CERTIFIED

Full Product Guide 2021

# TAKING YOUR UPFITS *TO THE NEXT LEVEL*

LEGEND FLEET SOLUTIONS Full Product Guide 2021

Legend Fleet Solutions, Inc.  
56957 Hwy 3 West, Tillsonburg, Ontario, N4G 4G8 Canada  
[www.legendfleet.com](http://www.legendfleet.com) | [customercare@legendfleet.com](mailto:customercare@legendfleet.com) | [info@legendfleet.com](mailto:info@legendfleet.com)  
P 519 688 1043 TF 866 223 2256

## TABLE OF CONTENTS

Our Mission	3
Protecting Your Fleet Investment	5
Aligning with the Future of Vehicles	9
Ford Vehicles & Layouts	11
RAM Vehicles & Layouts	17
Mercedes Vehicles & Layouts	23
Nissan Vehicles & Layouts	29
GM Vehicles & Layouts	33
Complete Kit Information	37
The Importance of Rigid Floors	39
StabiliGrip Rigid Floor	41
UltraGrip Rigid Floor	45
UltraFloor Rigid Floor	49
KK-Plus Rigid Floor	53
AutoMat-Bar Rubber Mat	57
Truck Bed Rubber Mat	61
DuraTherm Wall Liner	63
DuraTherm Ceiling Liner	69
DuraTherm Door Liner	75
Wheel Well Covers	79
Aluminium Sill Plates	81
Side and Rear Steel Thresholds	85
SecuriGrip Safety Accessories	87
ShoulderSink Mobile Handwashing Station	89
First Aid Kits	91
EconoLite Wall Liners	93
EconoLite Door Liners	97
EconoMat Rubber Mat	99
EconoFloor Rigid Floor	101

Let's protect today and tomorrow's fleet vehicles. Like a Legend.



# OUR MISSION

LEGEND FLEET SOLUTIONS TRANSFORMS INTERIOR SPACES OF TODAY AND TOMORROW'S FLEET VEHICLES, TAKING THE PROTECTION, SAFETY, PRODUCTIVITY OF MOBILE WORKFORCES TO THE NEXT LEVEL.



**3 VANS**  
**300 VANS**  
**3000 VANS**  
**300000 VANS**

NO MATTER THE SIZE OF YOUR FLEET,  
YOUR VEHICLES MUST BE PROTECTED FROM DAMAGE.

LEGEND INTERIOR PROTECTION PRODUCTS ARE  
FIELD-PROVEN, USED BY SOME OF THE LARGEST FLEETS  
IN NORTH AMERICA. AND, THE SMALLEST ONES.



## **KEEP PERSONNEL SAFE**

Prevent slips and falls with extreme anti-slip surfaces, easy-to-clean and mold-resistant products

## **PROTECT ASSETS AND BRAND TO REDUCE TOTAL COST OF OWNERSHIP**

Enhanced vehicle condition at end of vehicle life cycle

## **DRIVER COMFORT TO MAXIMIZE PRODUCTIVITY**

Flat floor, climate control, sound deadening, bright interiors



# PROTECT YOUR FLEET INVESTMENT

- **Increase Vehicle Resale Value**  
Highly durable products protect van panels from costly dents and damage and extend vehicle life
- **Optimize Operator Productivity**  
Enables ease of loading and operating conditions for technicians, reduce road noise
- **Create Safe Mobile Workspaces**  
Flat, anti-slip surfaces minimize trips and slips
- **Improve Professional Appearance**  
Clean, organized upfits enhance brand image
- **Proven Products in Field**  
Used in some of the largest fleets in North America
- **Extensive Product Access**  
Large network of upfitters across North America
- **Fast Quoting, Spec'ing Options**



Legend Fleet products are currently used in fleets of all sizes across North America, from last mile delivery and service vehicles to the utilities and telecom industry. Thousands of cargo van users rely on Legend interior protection to maximize the safety, comfort, and productivity of their mobile workforce and prevent costly damage to their assets.



# ALIGNING WITH THE **FUTURE** OF FLEET VEHICLES

For several years, Legend has taken steps towards a greener future. Before we actively embraced our environmental stewardship, our sister company used recycled rubber in the agriculture industry to produce flooring mats for dairy and beef cattle. Learning from our roots, we began incorporating recycled material into our products as well. Now, as we grow and recognize the need for everyone to do their part, Legend is committed to ongoing environmental responsibility in product development.

As the Fleet world begins to rapidly transform into a more sustainable, electric-forward industry, Legend is right along with it. We use recycled materials in most of our products. For example, our main rigid floor is made up of over 75% recycled material. Being part of something bigger enriches our team's positive outlook towards a greener industry and a more sustainable future!

**SUSTAINABLY  
SOURCED  
PRODUCTS**

**USING  
RECYCLED  
MATERIALS**

**MAKING  
GREENER  
CHOICES**

**REDUCING  
CARBON  
FOOTPRINT**

# A LEGEND IN THE MAKING THE **LIGHTWEIGHT** **FLOOR**

Currently in final trials, our new lightweight floor will be revolutionary for the future of the fleet industry.

Manufactured with a high percentage of recycled material this floor will maintain a very high co-efficient of friction Legend customers have come to expect.

Extending the range and maximizing payload while providing a safe, single level surface, this durable lightweight floor is the perfect protective option for all vehicles, especially Electric Vehicles.

STAY TUNED FOR THE DROP. COMING SOON.

**53%  
LIGHTER**



# **FORD**

VEHICLES





# FORD LAYOUTS



TRANSIT CONNECT (105") SWB  
 TRANSIT CONNECT (121") LWB  
 TRANSIT 130" WB LR  
 TRANSIT 130" WB MR  
 TRANSIT 148" WB LR  
 TRANSIT 148" WB MR  
 TRANSIT 148" WB HR  
 TRANSIT 148" EXT WB HR

TRANSIT 130" WB CREW  
 TRANSIT 148" WB CREW  
 TRANSIT 148" EXT WB CREW



Drawings intended to show how parts arrange in their respective, specific vehicles. Drawings not to scale.

**FORD TRANSIT CONNECT SWB**

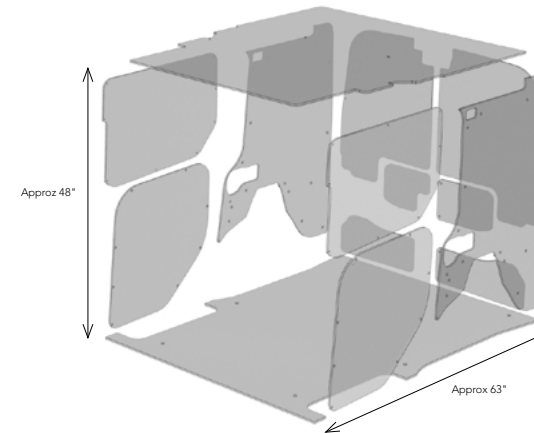

**FORD TRANSIT 130 MR**

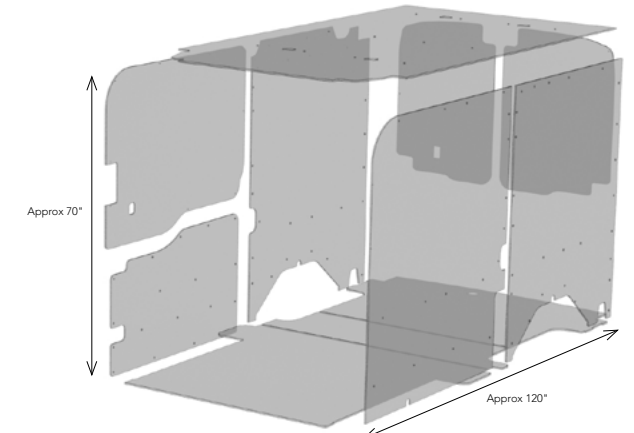

**FORD TRANSIT CONNECT LWB**

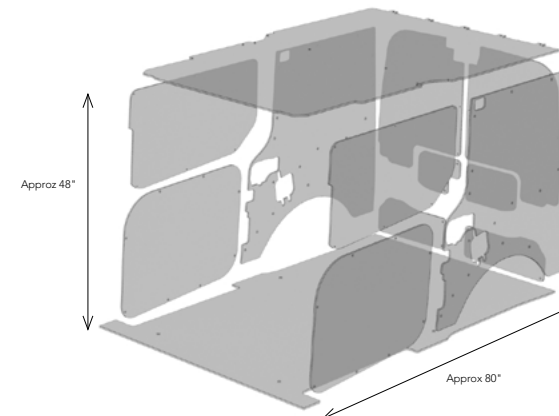

**FORD TRANSIT 148 LR**

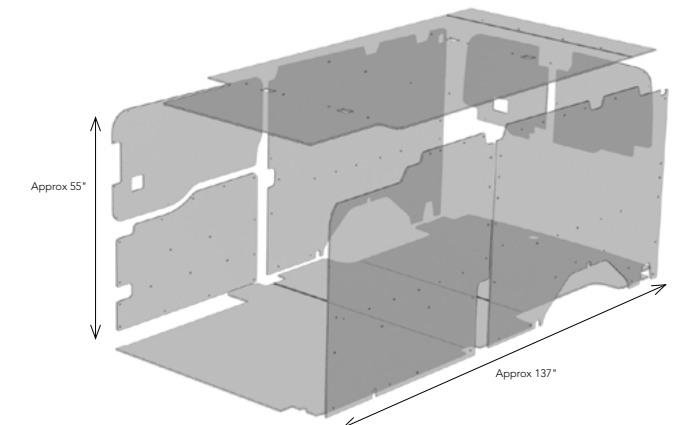

**FORD TRANSIT 130 LR**

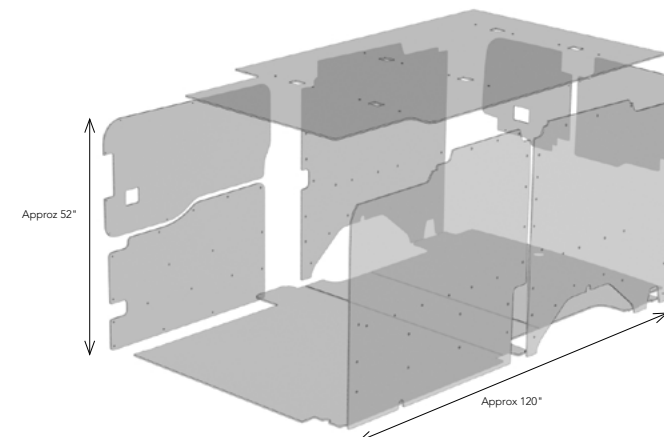

**FORD TRANSIT 148 MR**

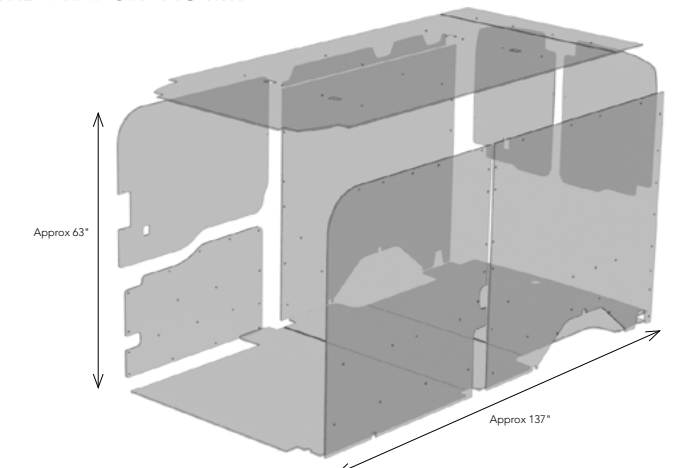



# FORD LAYOUTS

**FORD TRANSIT 148 HR**

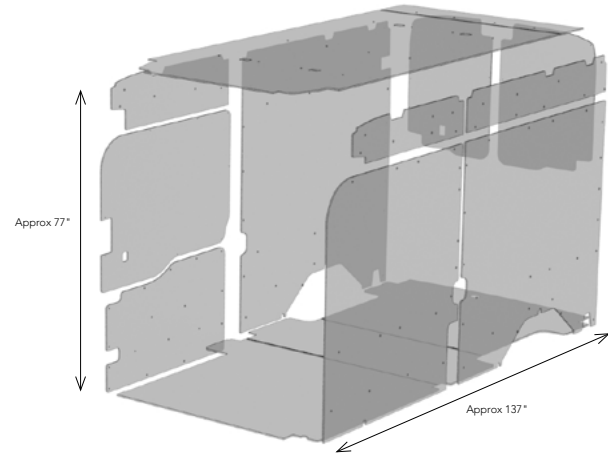

**FORD TRANSIT 130 LR CREW**

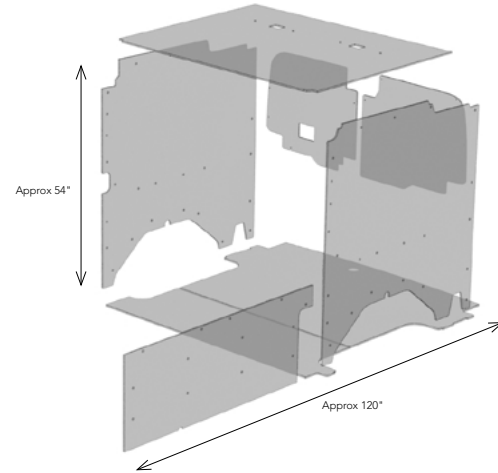

**FORD TRANSIT 148 MR CREW**

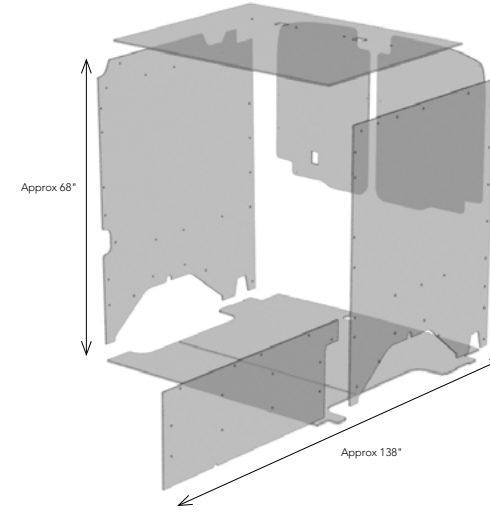

**FORD TRANSIT 148 EXT HR**

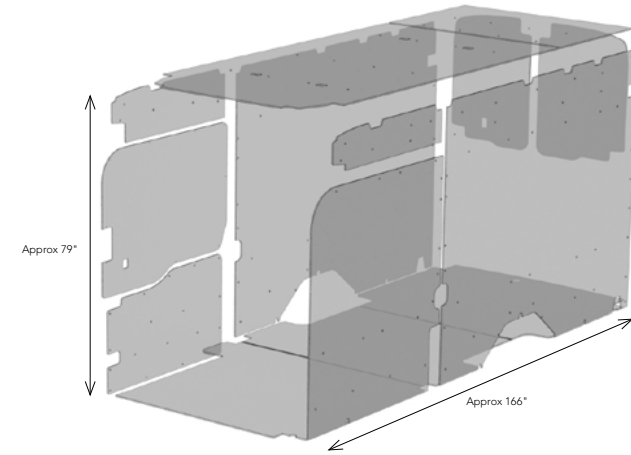

**FORD TRANSIT 130 MR CREW**

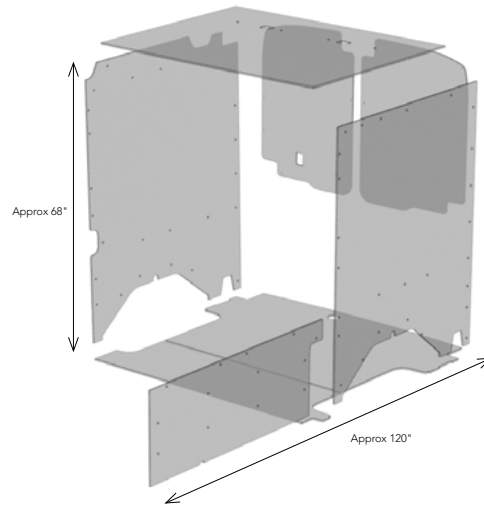

**FORD TRANSIT 148 HR CREW**

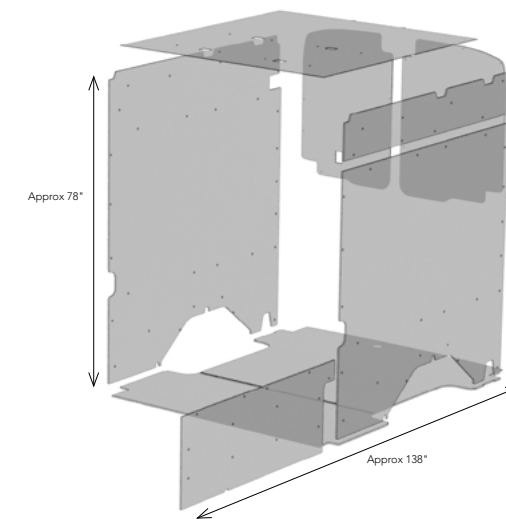

**FORD TRANSIT 148 LR CREW**

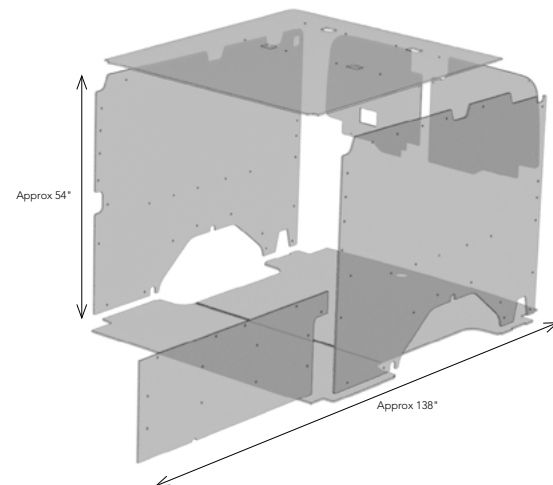

**FORD TRANSIT 148 EXT CREW**

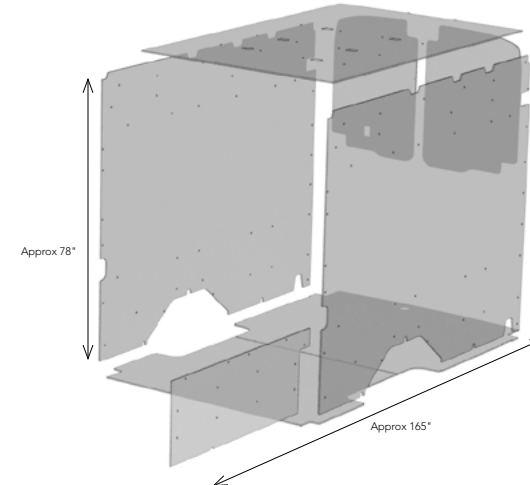

Drawings intended to show how parts arrange in their respective, specific vehicles.  
Drawings not to scale.



# RAM

VEHICLES





# RAM LAYOUTS



PROMASTER CITY (122" WB)  
 PROMASTER 118 WB LR  
 PROMASTER 136 WB LR  
 PROMASTER 136 WB HR  
 PROMASTER 159 WB HR  
 PROMASTER 159 EXT WB HR

PROMASTER 118" WB CREW  
 PROMASTER 136" WB CREW  
 PROMASTER 159" WB CREW  
 PROMASTER 159" EXT WB CREW



Drawings intended to show how parts arrange in their respective, specific vehicles. Drawings not to scale.

## RAM PROMASTER CITY

Please specify US or Canada version for all ProMaster City vehicles as these do vary.

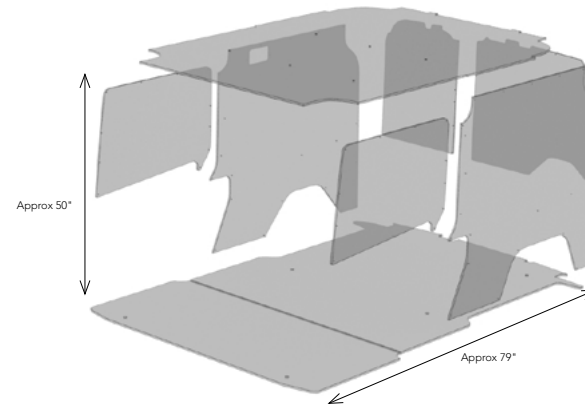

## RAM PROMASTER 136 HR

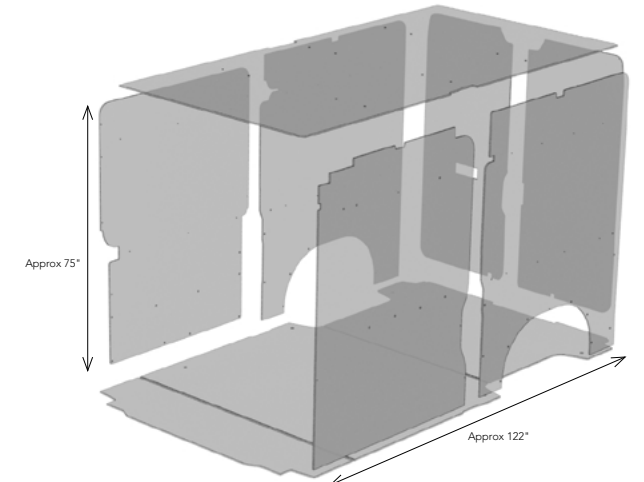

## RAM PROMASTER 118 LR

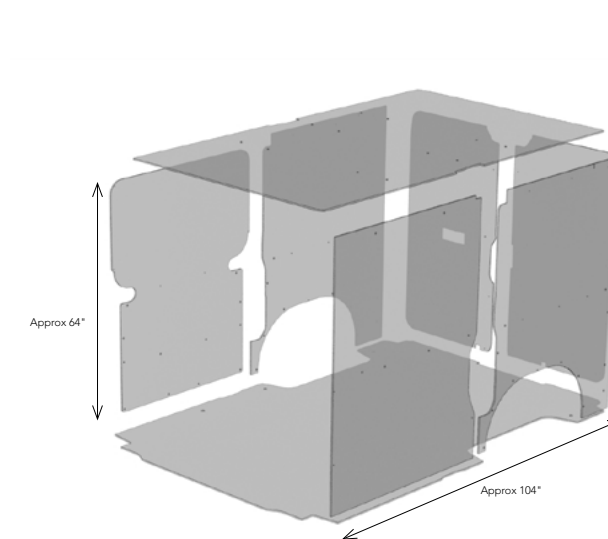

## RAM PROMASTER 159 HR

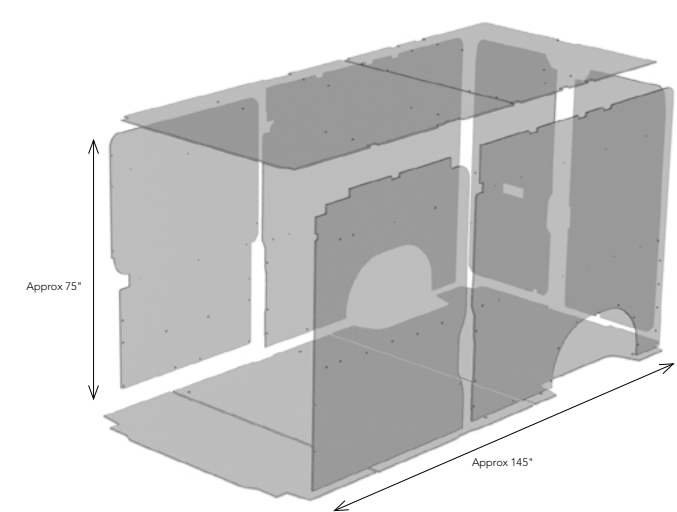

## RAM PROMASTER 136 LR

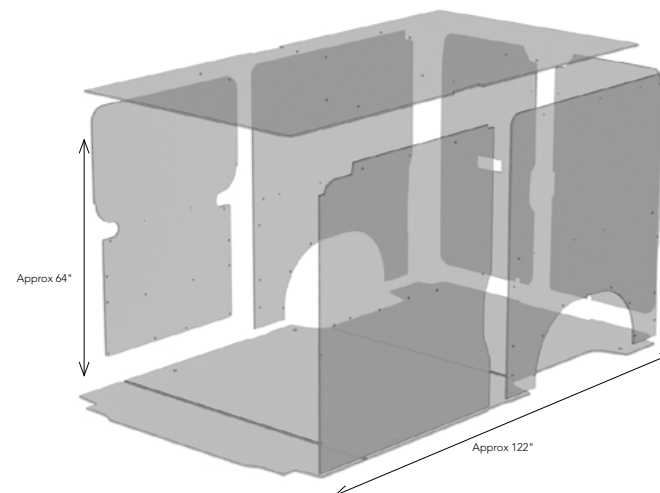

## RAM PROMASTER 159 EXT HR

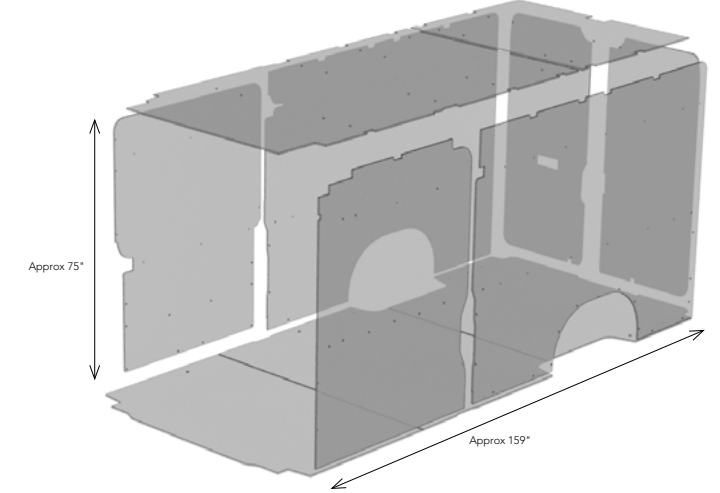



# RAM LAYOUTS

**RAM PROMASTER 118 CREW**

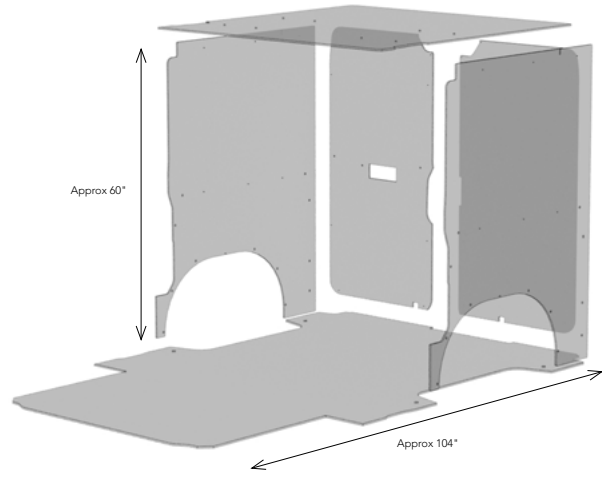

**RAM PROMASTER 159 CREW HR**

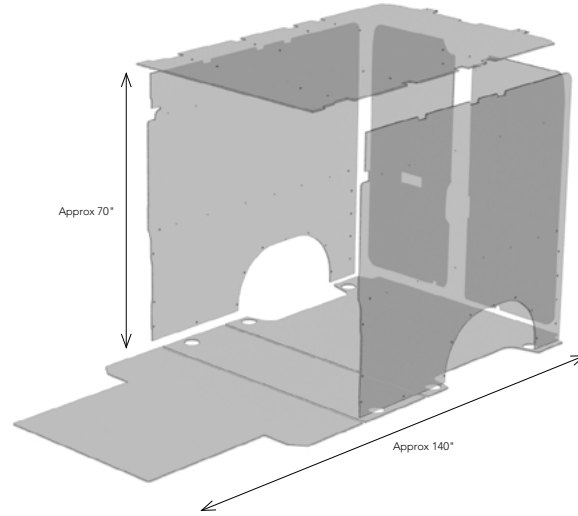

**RAM PROMASTER 136 LR CREW**

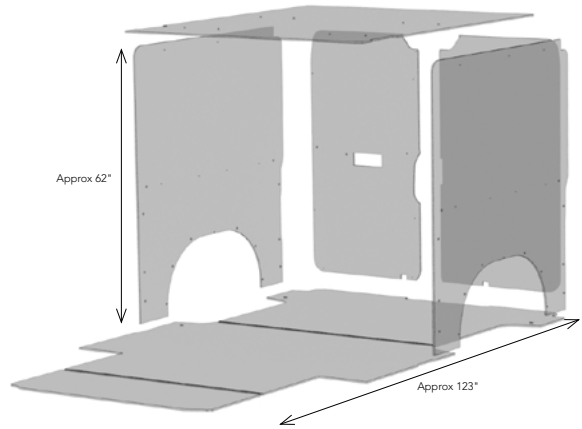

**RAM PROMASTER 159 EXT CREW**

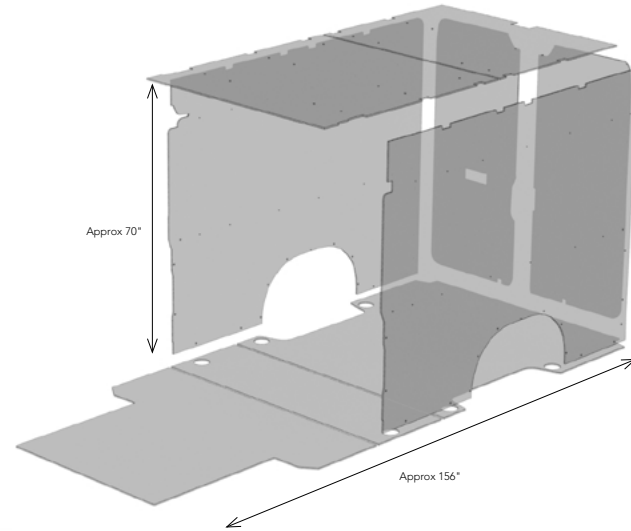

**RAM PROMASTER 136 HR CREW**

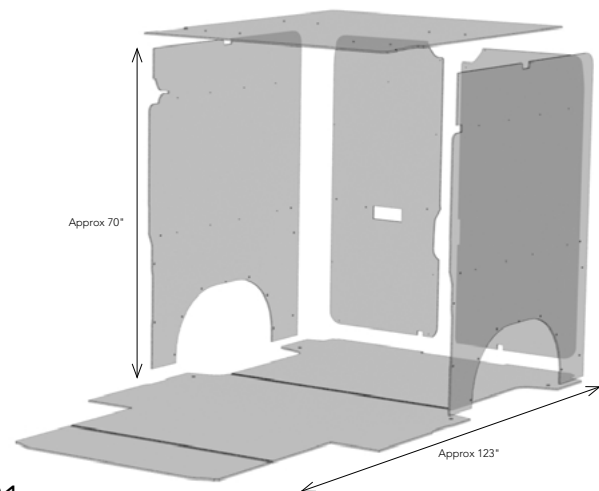

Drawings intended to show how parts arrange in their respective, specific vehicles.  
Drawings not to scale.





# **MERCEDES**

VEHICLES





# MERCEDES LAYOUTS



MERCEDES METRIS (126") RWB  
 MERCEDES METRIS (135") EWB  
 SPRINTER 144 WB LR  
 SPRINTER 144 WB HR  
 SPRINTER 170 WB  
 SPRINTER 170 EXT WB

SPRINTER 144 WB CREW  
 SPRINTER 170 WB CREW  
 SPRINTER 170 EXT WB CREW

Mercedes-Benz



Drawings intended to show how parts arrange in their respective, specific vehicles. Drawings not to scale.

**MERCEDES METRIS RWB**

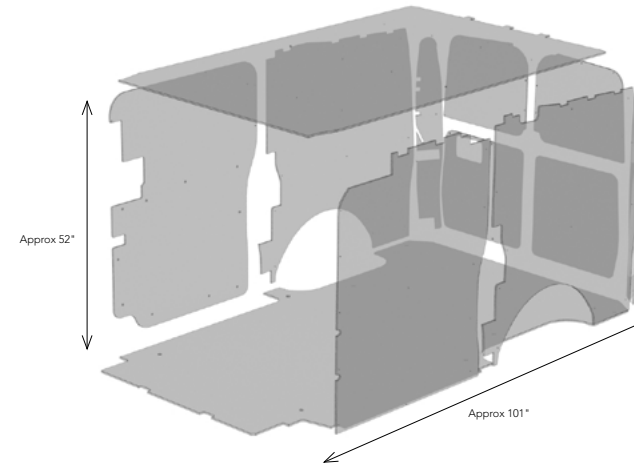

**SPRINTER 144 HR**

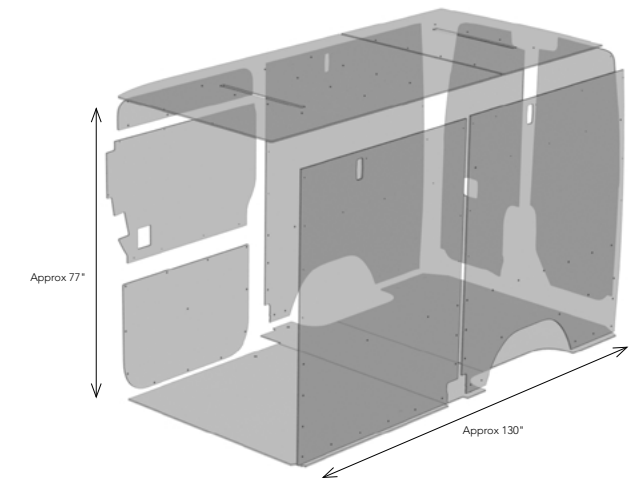

**MERCEDES METRIS EWB**

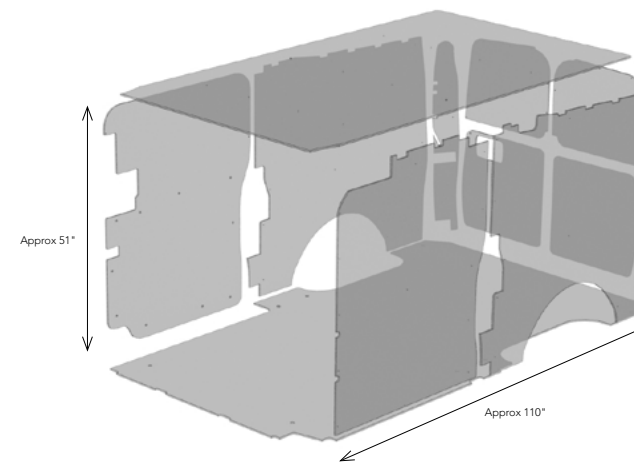

**SPRINTER 170**

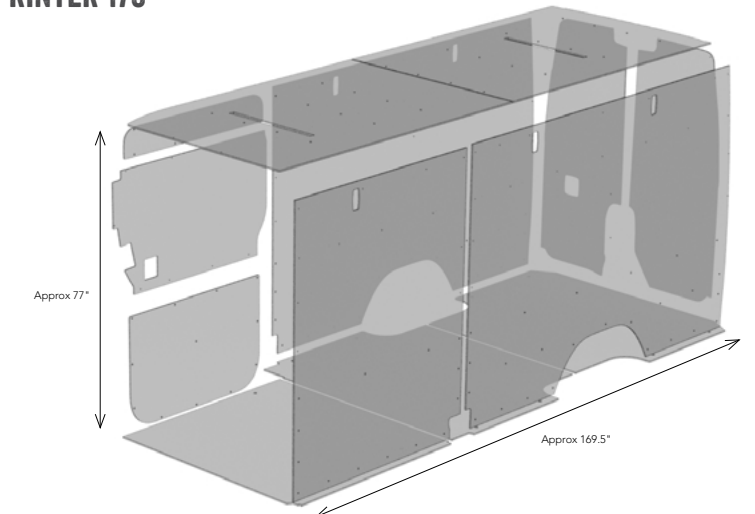

**SPRINTER 144 LR**

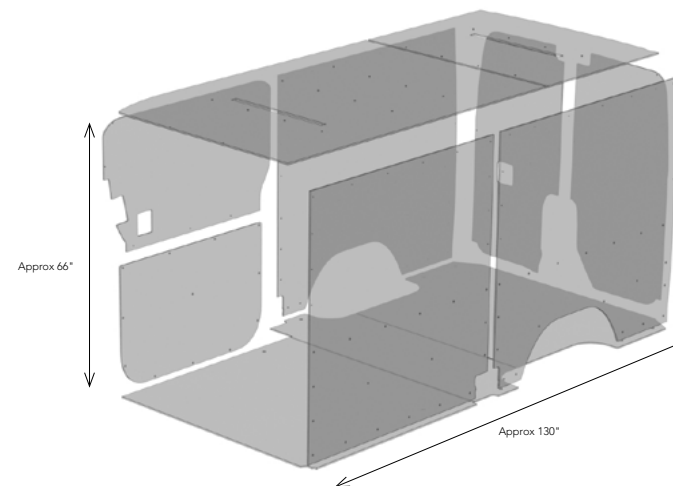

**SPRINTER 170 EXT**

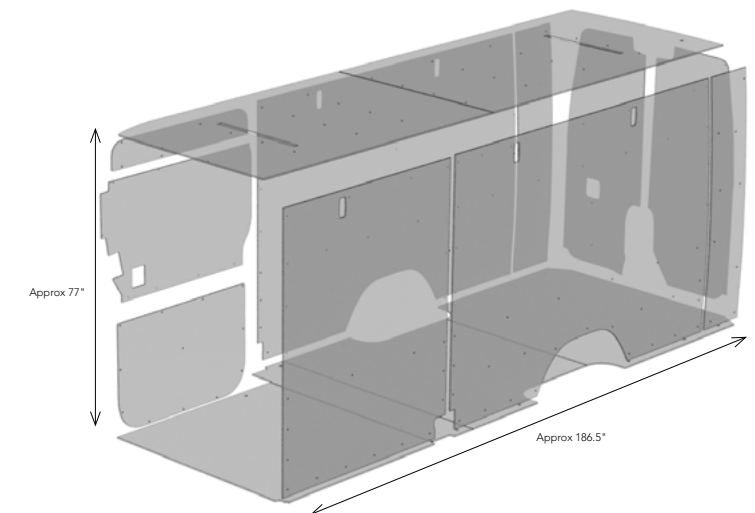



# MERCEDES LAYOUTS

**SPRINTER 144 LR CREW**

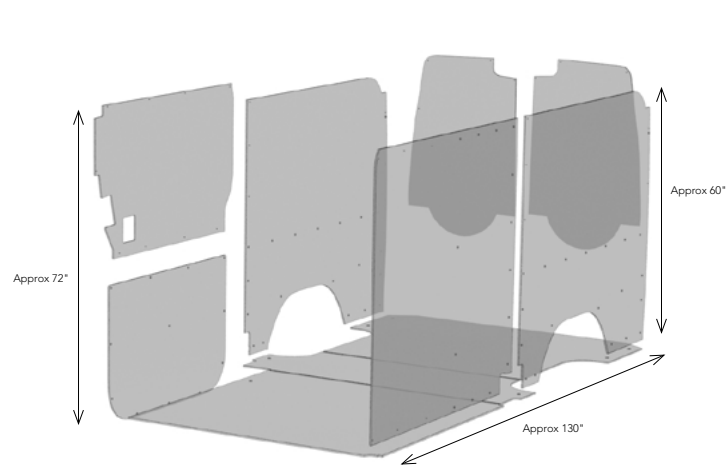

**SPRINTER 170 CREW**

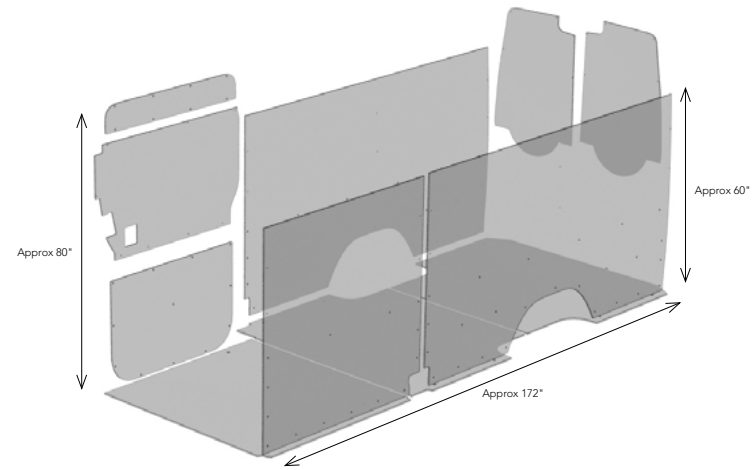

**SPRINTER 144 HR CREW**

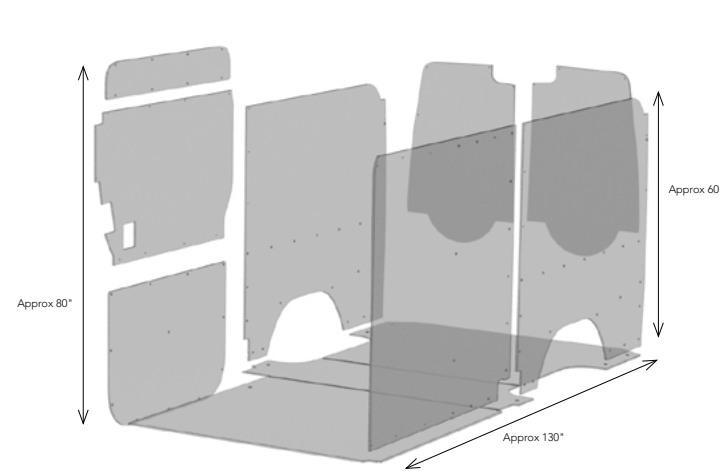

**SPRINTER 170 EXT CREW**

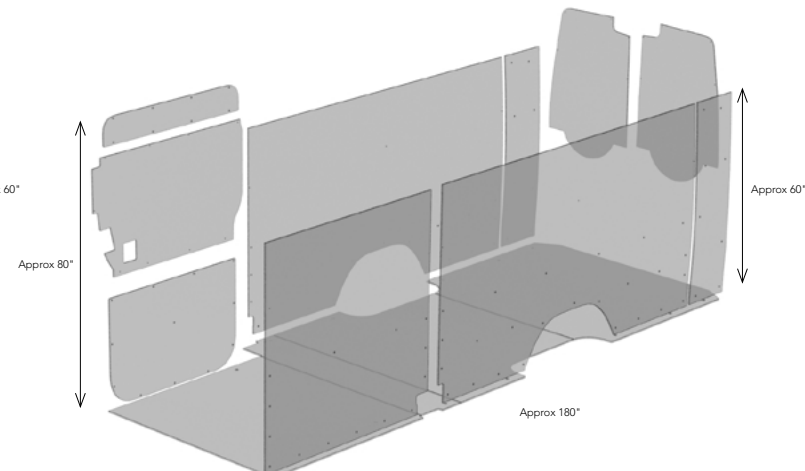

**NOTE ABOUT DIFFERENT SPRINTER WHEELBASES**



The measurement of the distance between both wheel wells for different Sprinter Rear Wheels Configurations' is below:

- Standard Single Wheels: Approx 53.75"
- Super Single Rear Wheels: Approx 49.00"
- Dual Rear Wheel: Approx 39.00"

Please pay attention to this to make sure you order the correct parts for your vehicle's configuration. If your vehicle has dual rear wheels or super single rear wheels, it will need a product extension found on the product pages.





# **NISSAN**

VEHICLES





# NISSAN LAYOUTS



NV200 (115" WB)  
NISSAN NV CARGO LR (140" WB)  
NISSAN NV CARGO HR (140" WB)



Drawings intended to show how parts arrange in their respective, specific vehicles. Drawings not to scale.

**NV200**

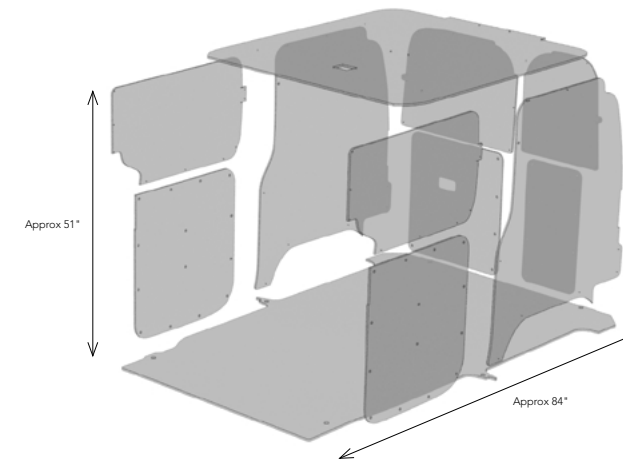

**NISSAN NV CARGO LR**

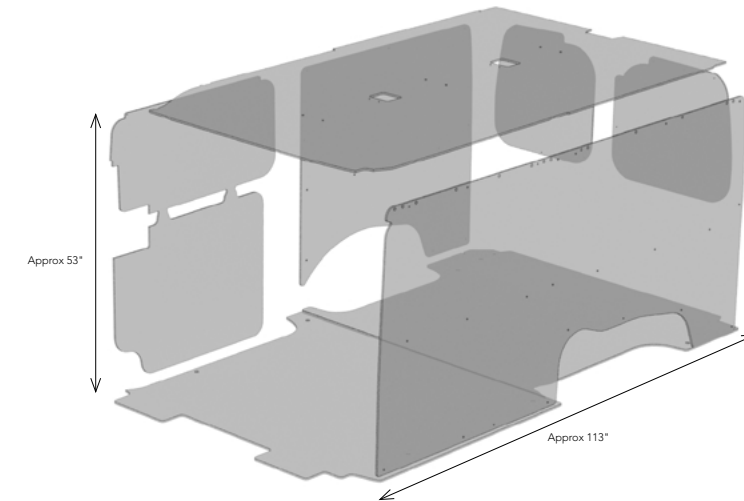

**NISSAN NV CARGO HR**

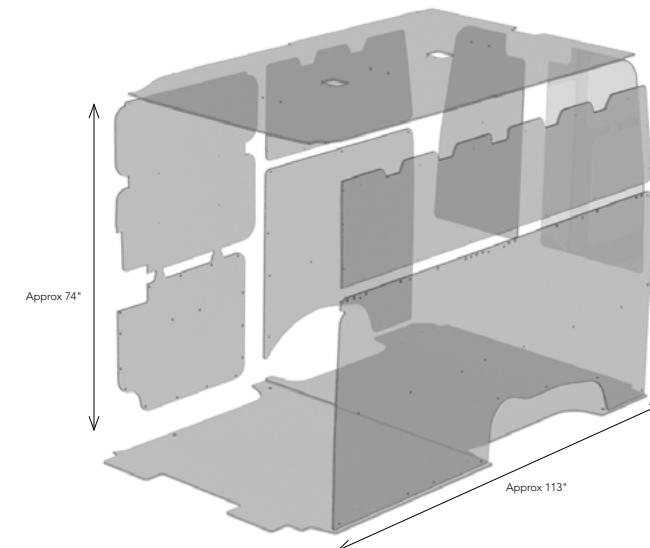

# **CHEVROLET**

VEHICLES





# GMC LAYOUTS



GMC SAVANA RWB/CHEVROLET EXPRESS  
(135") RWB

GMC SAVANA EWB/CHEVROLET EXPRESS  
(155") EWB



Drawings intended to show how parts arrange in their respective, specific vehicles. Drawings not to scale.

**GMC SAVANA RWB (135" WB)**

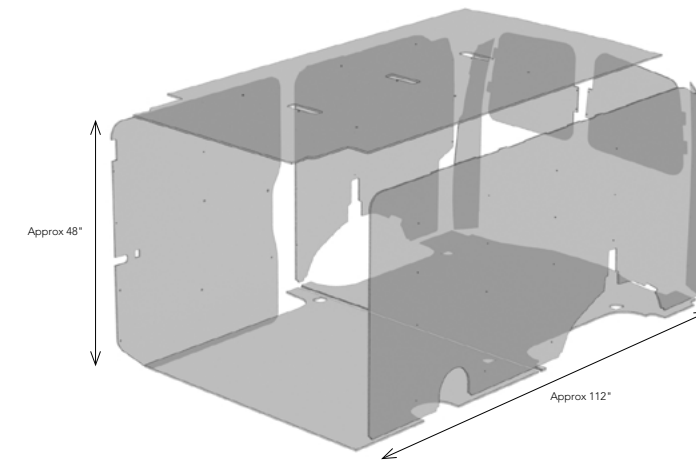

**GMC SAVANA EWB (155" WB)**

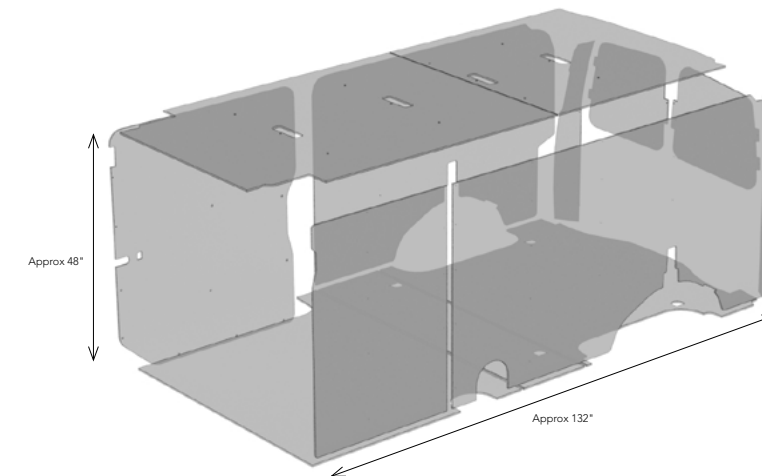

# COMPLETE

## KITS INCLUDE:

RIGID FLOOR + SILL PLATE SET  
INSULATED DURATHERM DOOR LINERS  
INSULATED DURATHERM WALL LINERS  
INSULATED DURATHERM CEILING LINERS  
WHEEL WELL COVERS *(Single Rear Wheels -Transit, ProMaster, Sprinter only)*

## PRODUCT EXTENSIONS

If your vehicle is a non-standard configuration, the following extensions must be added to the end of part numbers. For example, a StabiliGrip floor for a Ford Transit 130" WB dual sliding doors would be 731-135-6441.2.

- .1 Dual Wheels
- .2 Dual Side Sliding Doors
- .3 Hinged Side Doors
- .4 with OEM doorway step trim
- .5 Dual Doors and Dual Wheels
- .6 Super Single Rear Wheels
- .7 Rear Liftgate
- .8 Super Single and Dual Sliding Doors
- .9 Dual Wheels and OEM Trim
- .N No Side Doors
- .A Rear AC





# THE IMPORTANCE OF RIGID FLOORS IN CARGO VANS

A rigid floor eliminates the unevenness of the factory steel floor and creates a flat, safe working area for any mobile workspace, which ultimately maximizes productivity. All Legend floors are precision pre-cut to fit each cargo van, and can be customized to work even better for your fleet.

**SAFETY** – anti-slip surface for operator and cargo safety, prevents slips and trips

**EFFICIENCY** – flat working surface maximizes productivity by reducing strain on workers

**DURABILITY** – protect bare metal from impact and puncture damage

**PROFESSIONAL** – excellent brand image, easy-to-clean surface

**CHEMICAL/MOISTURE RESISTANT** – keeps work-surface dry, clean – will never rot

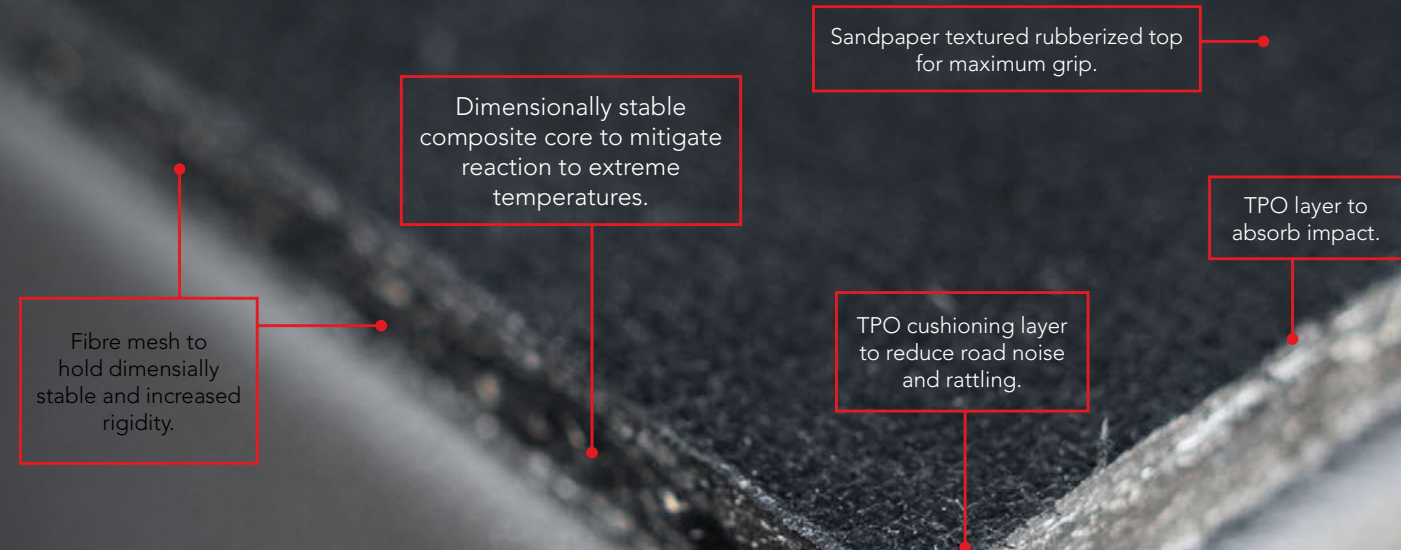

## WHERE DURABILITY AND SAFETY MATTER MOST



# STABILIGRIP

## THE ULTIMATE RIGID FLOOR



MADE OF  
MORE THAN  
**75%**  
RECYCLED  
MATERIALS

### INDUSTRY-LEADING ALL-PURPOSE FLOOR, BUILT FOR THE ROUGHEST WEAR AND TEAR.

StabiliGrip has proved itself as a leader in cargo van floor protection and operator safety. Its fine grip gives it the ability to slide material and still provide an extreme anti-slip surface, making it unbeatably versatile.

This legendary floor is also dimensionally-stable, meaning it will not expand and contract in extreme temperatures.

Due to its wide-ranging properties, this rigid floor allows operators of fleets of all vocations to perform their duties safely and efficiently.

- FINE GRIP MAKES FOR ALL-PURPOSE RIGID FLOOR
- WILL NOT WARP IN EXTREME TEMPERATURES
- IMPACT / PUNCTURE RESISTANT
- CHEMICAL / MOISTURE RESISTANT
- DECREASES ROAD NOISE
- SAFE, EFFICIENT, FLAT WORK-SURFACE
- EASY TO CLEAN
- MEETS FMVSS 302
- PROFESSIONAL BRAND IMAGE

STOCKED AT ALL  
WAREHOUSES



# STABILIGRIP SPECIFICATIONS

MAKE & MODEL      PART #      PCS      WEIGHT      INSTALL



Transit Connect (105") SWB	711-135-6441	1 pc	41 lbs	10 mins
Transit Connect (121") LWB	721-135-6541	1 pc	50 lbs	15 mins
Transit Connect LWB Dual Sliding Doors	721-135-6541.2	1 pc	50 lbs	10 mins
Transit 130" WB	731-135-6441	3 pc	118 lbs	20 mins
Transit 130" WB Dual Sliding Doors	731-135-6441.2	3 pc	114 lbs	20 mins
Transit 130" WB Crew	73C1-135-6441	2 pc	114 lbs	20 mins
Transit 148" WB	741-135-6441	3 pc	137 lbs	30 mins
Transit 148" WB Dual Sliding Doors	741-135-6441.2	3 pc	137 lbs	20 mins
Transit 148" WB Crew	74C1-135-6441	2 pc	122 lbs	20 mins
Transit 148" Extended WB	751-135-6441	3 pc	168 lbs	30 mins
Transit 148" Ext WB Dual Sliding Doors	751-135-6441.2	3 pc	168 lbs	30 mins
Transit 148" Extended WB Crew	75C1-135-6441	2 pc	135 lbs	30 mins

For the Transit Connect LWB, please use product extension .U (United States) or .C (Canada) for your country, as there are some design differences.



## Mercedes-Benz

Metris (126") RWB	151-135-6441	2 pc	92 lbs	20 mins
Metris RWB Dual Sliding Doors	151-135-6441.2	2 pc	92 lbs	20 mins
Metris (135") EWB	111-135-6441	2 pc	98 lbs	20 mins
Metris EWB Dual Sliding Doors	111-135-6441.2	2 pc	98 lbs	20 mins
Sprinter 144" WB	121-135-6441	3 pc	129 lbs	20 mins
Sprinter 144" WB Dual Sliding Doors	121-135-6441.2	3 pc	129 lbs	20 mins
Sprinter 170" Standard WB	131-135-6441	3 pc	178 lbs	20 mins
Sprinter 170" WB Dual Sliding Doors	131-135-6441.2	3 pc	178 lbs	20 mins
Sprinter 170" Extended WB	141-135-6441	4 pc	193 lbs	25 mins
Sprinter 170" Ext. WB Dual Sliding Doors	141-135-6441.2	4 pc	193 lbs	25 mins

Please specify vehicle model year when ordering.



NV 200 (115" WB)	531-135-6541	1 pc	70 lbs	15 mins
	531-135-6441	2 pc	70 lbs	10 mins
NV Cargo (140" WB)	511-135-6441	2 pc	114 lbs	20 mins

**ALL FLOORS INCLUDE SIDE AND REAR ALUMINIUM SILL PLATES.  
ALL CREW FLOORS INCLUDE THE REAR ALUMINIUM SILL PLATE ONLY.**

MAKE & MODEL      PART #      PCS      WEIGHT      INSTALL      T



C/V Tradesman (119" WB)*	612-135-6441	2 pc	45 lbs	10 mins
	612-135-6541	1 pc	45 lbs	15 mins
Chrysler Pacifica*	692-135-6441	2 pc	45 lbs	10 mins
	692-135-6541	1 pc	45 lbs	15 mins
Promaster City (122" WB)	671-135-6541	1 pc	70 lbs	20 mins
	671-135-6441	2 pc	70 lbs	15 mins
ProMaster 118" WB	621-135-6441	2 pc	109 lbs	20 mins
ProMaster 118" WB Crew	62C1-135-6441	2 pc	94 lbs	20 mins
ProMaster 136" WB	631-135-6441	2 pc	130 lbs	20 mins
ProMaster 136" WB Dual Sliding Doors	631-135-6441.2	2 pc	130 lbs	20 mins
ProMaster 136" WB Crew	63C1-135-6441	2 pc	105 lbs	20 mins
ProMaster 159" WB	641-135-6441	3 pc	145 lbs	25 mins
ProMaster 159" WB Dual Sliding Doors	641-135-6441.2	2 pc	145 lbs	25 mins
ProMaster 159" WB Crew	64C1-135-6441	3 pc	135 lbs	25 mins
ProMaster 159" Extended WB	651-135-6441	3 pc	173 lbs	25 mins
ProMaster 159" Ext. WB Dual Sliding Doors	651-135-6441.2	3 pc	173 lbs	25 mins
ProMaster 159" Extended WB	65C1-135-6441	3 pc	148 lbs	25 mins

For the ProMaster City, please use product extension .U (United States) or .C (Canada) for your country, as there are some design differences. Also please specify vehicle model year when ordering.



Chevy City Express (115") WB	361-135-6441	2 pc	70 lbs	15 mins
	361-135-6541	1 pc	70 lbs	10 mins
GMC Savana/ Chevy Express Regular (135") WB	311-135-6441	2 pc	107 lbs	20 mins
GMC Savana/ Chevy Express Extended (155") WB	321-135-6441	3 pc	130 lbs	20 mins

Floor info: pcs, weight, and install time doesn't include the sill set. Refer to page 54 for sill set information.

\*There are currently no sills available for C/V Tradesman or Chrysler Pacifica

## Additional Product Extensions

- .1 Dual Wheels
- .2 Dual Side Sliding Doors
- .4 with OEM doorway step trim
- .5 Dual Doors and Dual Wheels
- .6 Super Single Rear Wheels
- .8 Super Single and Dual Sliding Doors
- .9 Dual Wheels and OEM Trim
- .N No Side Doors
- .A Rear AC
- .H Handbrake console cutout



# ULTRAGRIP

## GRIPPY COMPOSITE FLOOR

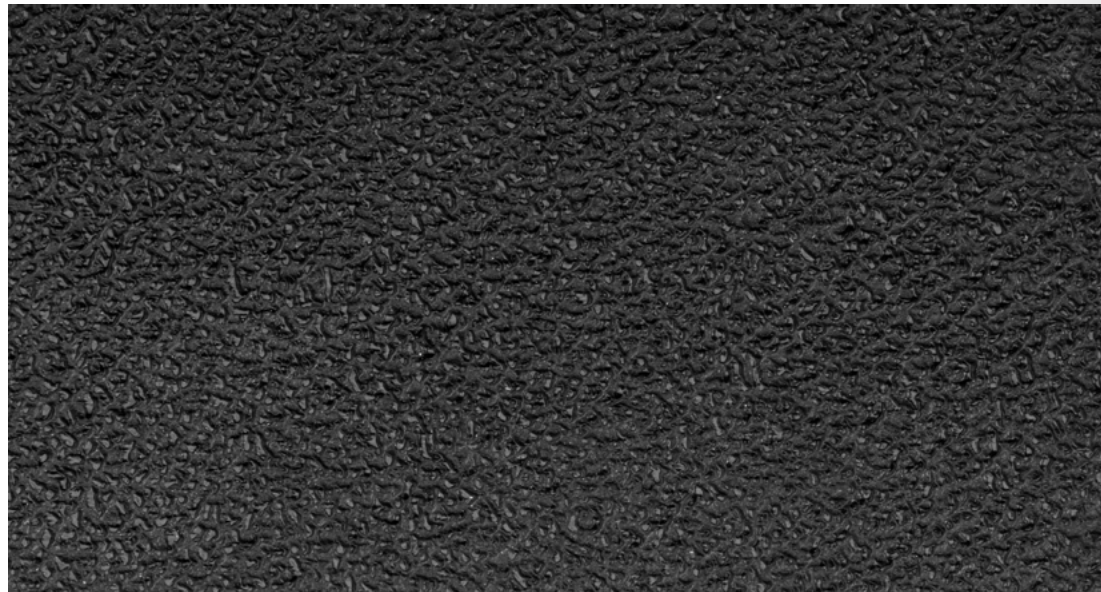

UltraGrip offers an extremely grippy surface for cargo van applications , which creates a reliable surface for operators to work in. Due to being a high density plastic, this floor does have a high expansion and contraction rate; care needs to be taken when mounting product over top of this floor.

- RIGID HDPE PLASTIC FLOOR FOR DURABILITY
- IMPACT / PUNCTURE RESISTANT
- UNIQUE RUBBERIZED SURFACE FOR SAFETY
- MAINTENANCE FREE
- SAFE, EFFICIENT WORK-SURFACE
- EXTREME ANTI-SLIP





# ULTRAGRIP SPECIFICATIONS

**ALL FLOORS INCLUDE SIDE AND REAR ALUMINIUM SILL PLATES.  
ALL CREW FLOORS INCLUDE THE REAR ALUMINIUM SILL PLATE ONLY.**

Floor info: pcs, weight, and install time doesn't include the sill set. Refer to page 54 for sill set information.

\*There are currently no sills available for C/V Tradesman or Chrysler Pacifica

MAKE & MODEL	PART #	PCS	WEIGHT	INSTALL
				
Transit Connect (105") SWB	711-162-6441	1 pc	41 lbs	15 mins
Transit Connect (121") LWB	721-162-6441	2 pc	50 lbs	15 mins
Transit Connect LWB Dual Sliding Doors	721-162-6541.2	1 pc	50 lbs	10 mins
Transit 130" WB	731-162-6441	2 pc	114 lbs	20 mins
Transit 130" WB Dual Sliding Doors	731-162-6441.2	1 pc	114 lbs	15 mins
Transit 148" WB	741-162-6441	3 pc	122 lbs	20 mins
Transit 148" WB Dual Sliding Doors	741-162-6441.2	3 pc	122 lbs	20 mins
Transit 148" Extended WB	751-162-6441	3 pc	142 lbs	25 mins
Transit 148" Ext. WB Dual Sliding Doors	751-162-6441	3 pc	142 lbs	25 mins

For the Transit Connect LWB, please use product extension .U (United States) or .C (Canada) for your country, as there are some design differences.



## Mercedes-Benz

Metris (126") RWB	151-162-6441	2 pc	108 lbs	20 mins
Metris RWB Dual Sliding Doors	151-162-6441.2	2 pc	108 lbs	20 mins
Metris (135") EWB	111-162-6441	2 pc	110 lbs	20 mins
Metris RWB Dual Sliding Doors	111-162-6441	2 pc	110 lbs	20 mins
Sprinter 144" WB	121-162-6441	3 pc	121 lbs	20 mins
Sprinter 144" WB Dual Sliding Doors	121-162-6441	3 pc	121 lbs	20 mins
Sprinter 170" Standard WB	131-162-6441	3 pc	151 lbs	20 mins
Sprinter 170" WB Dual Sliding Doors	131-162-6441	3 pc	151 lbs	20 mins
Sprinter 170" Extended WB	141-162-6441	4 pc	168 lbs	25 mins
Sprinter 170" Ext. WB Dual Sliding Doors	141-162-6441.2	3 pc	168 lbs	25 mins

Please specify vehicle model year when ordering.

Floor info: pcs, weight, and install time doesn't include the sill set. Refer to page 54 for sill set information.

\*There are currently no sills available for C/V Tradesman

## Additional Product Extensions

- |                               |  |
|-------------------------------|--|
| .1 Dual Wheels                | .8 Super Single and Dual Sliding Doors |
| .2 Dual Side Sliding Doors    | .9 Dual Wheels and OEM Trim            |
| .4 with OEM doorway step trim | .N No Side Doors                       |
| .5 Dual Doors and Dual Wheels | .A Rear AC                             |
| .6 Super Single Rear Wheels   | .H Handbrake console cutout            |

MAKE & MODEL	PART #	PCS	WEIGHT	INSTALL
				
C/V Tradesman*	612-162-6441	2 pc	90 lbs	20 mins
	612-162-6541	1 pc	90 lbs	20 mins
Chrysler Pacifica*	692-135-6441	2 pc	90 lbs	20 mins
	692-135-6541	1 pc	90 lbs	20 mins
ProMaster City (122" WB)	671-162-6441	2 pc	82 lbs	20 mins
	671-162-6541	1 pc	82 lbs	15 mins
ProMaster 118" WB	621-162-6441	2 pc	94 lbs	20 mins
	621-162-6641	1 pc	94 lbs	15 mins
ProMaster 136" WB	631-162-6441	2 pc	105 lbs	20 mins
ProMaster 136" WB Dual Sliding Doors	631-162-6441.2	2 pc	105 lbs	20 mins
ProMaster 159" WB	641-162-6441	3 pc	135 lbs	25 mins
ProMaster 159" WB Dual Sliding Doors	641-162-6441.2	2 pc	135 lbs	25 mins
ProMaster 159" Extended WB	651-162-6441	3 pc	148 lbs	25 mins
ProMaster 159" Ext. WB Dual Sliding Doors	651-162-6441	3 pc	148 lbs	25 mins

For the ProMaster City, please use product extension .U (United States) or .C (Canada) for your country, as there are some design differences. Also please specify vehicle model year when ordering.



Chevy City Express (115") WB	361-162-6441	2 pc	52 lbs	15 mins
	361-162-6541	1 pc	52 lbs	10 mins
GMC Savana/ Chevy Express Regular (135") WB	311-162-6441	2 pc	105 lbs	20 mins
	311-162-6641	1 pc	105 lbs	15 mins
GMC Savana/ Chevy Express Extended (155") WB	321-162-6441	3 pc	114 lbs	20 mins
	321-162-6641	2 pc	114 lbs	20 mins



NV 200 (115" WB)	531-162-6441	2 pc	52 lbs	15 mins
	531-162-6641	1 pc	52 lbs	10 mins
NV Cargo (140" WB)	511-162-6441	2 pc	112 lbs	20 mins
	511-162-6541	1 pc	112 lbs	15 mins



# ULTRAFLOOR

## RIGID FLOOR FOR LOADING CARGO

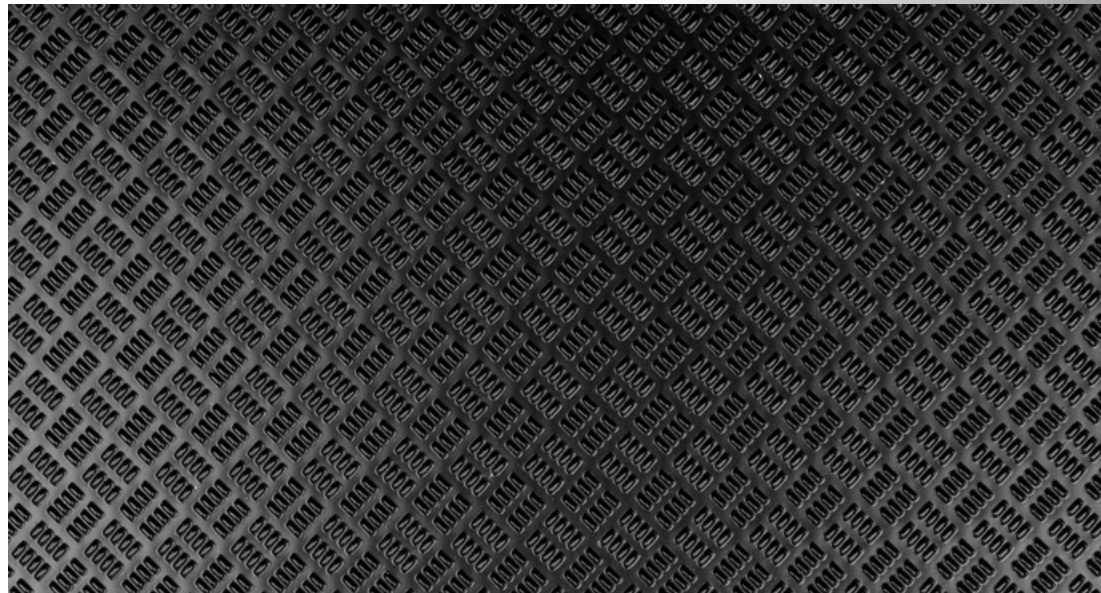

This durable rigid floor is excellent for loading and unloading heavy cargo due to its slippery texture\*.

\*Operators should take caution when walking on the floor.

- RIGID HDPE PLASTIC FLOOR FOR DURABILITY
- NON-POROUS PLASTIC - RESISTS STAINS AND MOLD
- IDEAL FOR LOADING PALLETS AND CARGO - RIDGES ALLOW EASY SLIDES
- MAINTENANCE-FREE



# ULTRAFLOOR SPECIFICATIONS

**ALL FLOORS INCLUDE SIDE AND REAR ALUMINIUM SILL PLATES.  
ALL CREW FLOORS INCLUDE THE REAR ALUMINIUM SILL PLATE ONLY.**

Floor info: pcs, weight, and install time doesn't include the sill set. Refer to page 54 for sill set information.

\*There are currently no sills available for C/V Tradesman or Chrysler Pacifica

MAKE & MODEL	PART #	PCS	WEIGHT	INSTALL
				
Transit Connect (105") SWB	711-061-6441	1 pc	39 lbs	10 mins
Transit Connect (121") LWB	721-061-6441	2 pc	48 lbs	15 mins
Transit Connect LWB Dual Sliding Doors	721-061-6441.2	2 pc	48 lbs	10 mins
Transit 130" WB	731-061-6441	2 pc	108 lbs	20 mins
Transit 103" WB Dual Sliding Doors	731-061-6441.2	2 pc	108 lbs	20 mins
Transit 148" WB	741-061-6441	3 pc	116 lbs	20 mins
Transit 148" WB Dual Sliding Doors	741-061-6441.2	3 pc	116 lbs	20 mins
Transit 148" Extended WB	751-061-6441	3 pc	135 lbs	25 mins
Transit 148" Ext. Dual Sliding Doors	751-061-6441.2	3 pc	135 lbs	25 mins

For the Transit Connect LWB, please use product extension .U (United States) or .C (Canada) for your country, as there are some design differences.



## Mercedes-Benz

Metris (126") RWB	151-061-6441	2 pc	103 lbs	20 mins
Metris RWB Dual Sliding Doors	151-061-6441.2	2 pc	103 lbs	20 mins
Metris (135") EWB	111-061-6441	2 pc	110 lbs	20 mins
Metris EWB Dual Sliding Doors	111-061-6441.2	2 pc	110 lbs	20 mins
Sprinter 144" WB	121-061-6441	3 pc	115 lbs	20 mins
Sprinter 144" WB Dual Sliding Doors	121-061-6441.2	3 pc	115 lbs	20 mins
Sprinter 170" Standard WB	131-061-6441	3 pc	143 lbs	20 mins
Sprinter 170" WB Dual Sliding Doors	131-061-6441.2	3 pc	143 lbs	20 mins
Sprinter 170" Extended WB	141-061-6441	4 pc	160 lbs	25 mins
Sprinter 170" Ext. WB Dual Sliding Doors	141-061-6441.2	4 pc	160 lbs	25 mins

Floor info: pcs, weight, and install time doesn't include the sill set. Refer to page 54 for sill set information.

Please specify vehicle model year when ordering.

\*There are currently no sills available for C/V Tradesman

## Additional Product Extensions

- .1 Dual Wheels
- .2 Dual Side Sliding Doors
- .4 with OEM doorway step trim
- .5 Dual Doors and Dual Wheels
- .6 Super Single Rear Wheels
- .8 Super Single and Dual Sliding Doors
- .9 Dual Wheels and OEM Trim
- .N No Side Doors
- .A Rear AC
- .H Handbrake console cutout

MAKE & MODEL	PART #	PCS	WEIGHT	INSTALL
 <b>RAM</b>				
C/V Tradesman* (119" WB)	612-061-6441	2 pc	90 lbs	20 mins
Chrysler Pacifica*	612-061-6541	1 pc	90 lbs	20 mins
	692-061-6441	2 pc	90 lbs	20 mins
	692-061-6541	1 pc	90 lbs	20 mins
ProMaster City (122" WB)	671-061-6441	2 pc	78 lbs	20 mins
	671-061-6541	1 pc	78 lbs	20 mins
ProMaster 118" WB	621-061-6441	2 pc	89 lbs	20 mins
	621-061-6641	1 pc	89 lbs	20 mins
ProMaster 136" WB	631-061-6441	2 pc	100 lbs	20 mins
ProMaster 136" WB Dual Sliding Doors	631-061-6441.2	2 pc	100 lbs	20 mins
ProMaster 159" WB	641-061-6441	3 pc	128 lbs	25 mins
ProMaster 159" WB Dual Sliding Doors	641-061-6441.2	3 pc	128 lbs	25 mins
ProMaster 159" Extended WB	651-061-6441	3 pc	141 lbs	25 mins
ProMaster 159" Ext. WB Dual Sliding Doors	651-061-6441.2	3 pc	141 lbs	25 mins

For the ProMaster City, please use product extension .U (United States) or .C (Canada) for your country, as there are some design differences. Also please specify vehicle model year when ordering.



Chevy City Express (115") WB	361-061-6441	2 pc	49 lbs	15 mins
	361-061-6541	1 pc	49 lbs	10 mins
GMC Savana/ Chevy Express Regular (135") WB	311-061-6441	2 pc	100 lbs	20 mins
	311-061-6641	1 pc	100 lbs	15 mins
GMC Savana/ Chevy Express Extended (155") WB	321-061-6441	3 pc	108 lbs	20 mins
	321-061-6641	2 pc	108 lbs	20 mins



NV 200 (115" WB)	531-061-6441	2 pc	49 lbs	15 mins
	531-061-6541	1 pc	49 lbs	10 mins
NV Cargo (140" WB)	511-061-6441	2 pc	106 lbs	20 mins
	511-061-6641	1 pc	106 lbs	15 mins



# KK-PLUS

## PLYWOOD RIGID FLOORING



With a high-quality 9-ply core, this birch plywood floor is extremely durable. Unlike other cheaper wood floors on the market, this rigid floor is reliable, long-lasting, and built for wear and tear.

- 9-PLY BIRCH PLYWOOD; EXTREMELY RIGID
- WEAR-RESISTANT PHENOLIC RESIN COATING
- TEXTURED SURFACE FOR TRACTION AND SAFETY
- VERY STABLE - LOW EXPANSION AND CONTRACTION



# KK-PLUS SPECIFICATIONS

MAKE & MODEL	PART #	PCS	WEIGHT	INSTALL
				
Transit Connect (105") SWB	711-112-4442	1 pc	40 lbs	10 mins
Transit Connect (121") LWB	721-112-4442	2 pc	49 lbs	15 mins
	721-112-4542	1 pc	49 lbs	10 mins
Transit Connect LWB Dual Sliding Doors	721-112-4442	2 pc	49 lbs	15 mins
Transit 130" WB	731-112-4442	2 pc	111 lbs	20 mins
Transit 130" WB Dual Sliding Doors	731-112-4442.2	2 pc	111 lbs	20 mins
Transit 130" WB Crew	73C1-112-4442	2 pc	111 lbs	20 mins
Transit 148" WB	741-112-4442	3 pc	119 lbs	20 mins
Transit 148" WB Dual Sliding Doors	741-112-4442.2	3 pc	119 lbs	20 mins
Transit 148" WB Crew	74C1-112-4642	2 pc	119 lbs	20 mins
Transit 148" Extended WB	751-112-4442	3 pc	138 lbs	25 mins
Transit 148" Ext. WB Dual Sliding Doors	751-112-4442.2	3 pc	138 lbs	25 mins
Transit 148" Extended WB Crew	75C1-112-4642	2 pc	138 lbs	25 mins



## Mercedes-Benz

For the Transit Connect LWB, please use product extension .U (United States) or .C (Canada) for your country, as there are some design differences.

Metris (126") RWB	151-112-4442	2 pc	105 lbs	20 mins
	151-112-4542	1 pc	105 lbs	15 mins
Metris RWB Dual Sliding Doors	151-112-4442.2	2 pc	105 lbs	20 mins
Metris (135") EWB	111-112-4442	2 pc	110 lbs	20 mins
Metris EWB Dual Sliding Doors	111-112-4442.2	2 pc	110 lbs	20 mins
Sprinter 144" WB	121-112-4442	3 pc	118 lbs	20 mins
Sprinter 144" WB Dual Sliding Doors	121-112-4442.2	3 pc	118 lbs	20 mins
Sprinter 144" WB Crew	12C1-112-4642	2 pc	115 lbs	20 mins
Sprinter 170" Standard WB	131-112-4442	3 pc	147 lbs	20 mins
Sprinter 170" WB Dual Sliding Doors	131-112-4442.2	3 pc	147 lbs	20 mins
Sprinter 170" Standard WB Crew	13C1-112-4642	2 pc	140 lbs	20 mins
Sprinter 170" Extended WB	141-112-4442	4 pc	164 lbs	25 mins
Sprinter 170" Ext. WB Dual Sliding Doors	141-112-4442.2	4 pc	164 lbs	25 mins
Sprinter 170" Extended WB Crew	14C1-112-4642	2 pc	155 lbs	25 mins

### Additional Product Extensions

Please specify vehicle model year when ordering.

- .1 Dual Wheels
- .2 Dual Side Sliding Doors
- .4 with OEM doorway step trim
- .5 Dual Doors and Dual Wheels
- .6 Super Single Rear Wheels
- .8 Super Single and Dual Sliding Doors
- .9 Dual Wheels and OEM Trim
- .N No Side Doors
- .A Rear AC
- .H Handbrake console cutout

**ALL FLOORS INCLUDE SIDE AND REAR ALUMINIUM SILL PLATES.  
ALL CREW FLOORS INCLUDE THE REAR ALUMINIUM SILL PLATE ONLY.**

Floor info: pcs, weight, and install time doesn't include the sill set. Refer to page 54 for sill set information.

\*There are currently no sills available for C/V Tradesman or Chrysler Pacifica

MAKE & MODEL	PART #	PCS	WEIGHT	INSTALL
				
C/V Tradesman* (119" WB)	612-112-4442	2 pc	82 lbs	20 mins
	612-112-4542	1 pc	82 lbs	15 mins
Chrysler Pacifica*	692-112-4442	2 pc	82 lbs	20 mins
	692-112-4542	1 pc	82 lbs	15 mins
ProMaster City (122" WB)	671-112-4442	2 pc	80 lbs	20 mins
	671-112-4542	1 pc	80 lbs	15 mins
ProMaster 118" WB	621-112-4442	2 pc	92 lbs	20 mins
ProMaster 118" WB Crew	62C1-112-4542	1 pc	90 lbs	15 mins
ProMaster 136" WB	631-112-4442	2 pc	102 lbs	20 mins
ProMaster 136" WB Dual Sliding Doors	631-112-4442.2	2 pc	102 lbs	20 mins
ProMaster 136" WB Crew	63C1-112-4642	1 pc	95 lbs	15 mins
ProMaster 159" WB	641-112-4442	3 pc	131 lbs	25 mins
ProMaster 159" WB Dual Sliding Doors	641-112-4442.2	3 pc	131 lbs	25 mins
ProMaster 159" WB Crew	64C1-112-4642	2 pc	125 lbs	25 mins
ProMaster 159" Extended WB	651-112-4442	3 pc	144 lbs	25 mins
ProMaster 159" Ext. WB Dual Sliding Doors	651-112-4442.2	3 pc	144 lbs	25 mins
ProMaster 159" Extended WB Crew	65C1-112-4642	2 pc	135 lbs	25 mins

For the ProMaster City, please use product extension .U (United States) or .C (Canada) for your country, as there are some design differences.  
Also please specify vehicle model year when ordering.



Chevy City Express (115") WB	361-112-4442	2 pc	51 lbs	15 mins
	361-112-4542	1 pc	51 lbs	10 mins
GMC Savana/ Chevy Express Regular (135") WB	311-112-4442	2 pc	102 lbs	20 mins
	311-112-4642	1 pc	102 lbs	15 mins
GMC Savana/ Chevy Express Extended (155") WB	321-112-4442	3 pc	111 lbs	20 mins
	321-112-4642	2 pc	111 lbs	20 mins



NV 200 (115" WB)	531-112-4442	2 pc	51 lbs	15 mins
	531-112-4542	1 pc	51 lbs	10 mins
NV Cargo (140" WB)	511-112-4442	2 pc	109 lbs	20 mins
	511-112-4642	1 pc	109 lbs	15 mins



# AUTOMAT-BAR

## ALL-PURPOSE RUBBER MAT

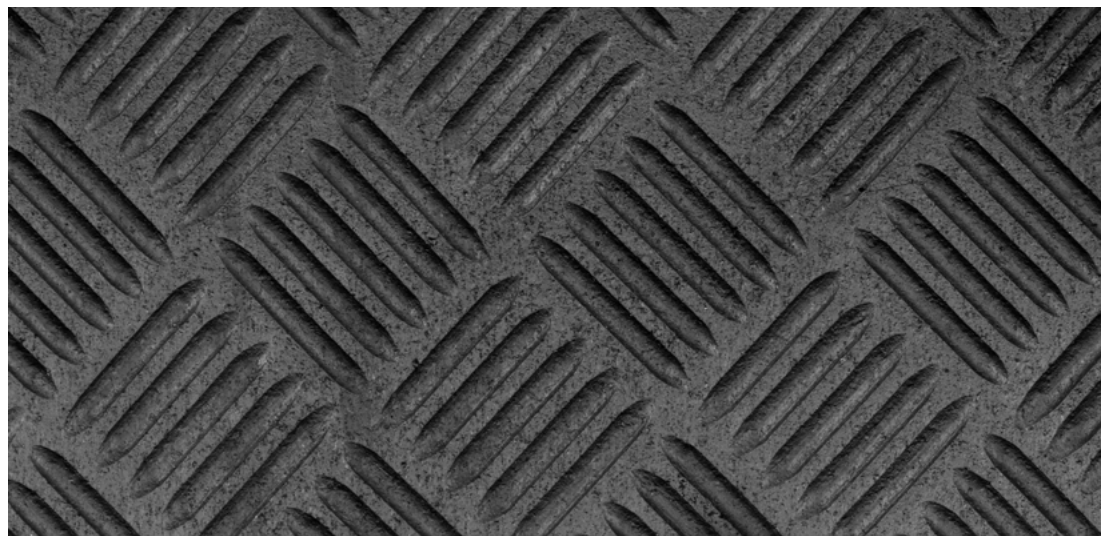

- INCREDIBLE TRACTION FOR ANTI-SLIP
- HEAVY DUTY INDUSTRIAL STRENGTH
- ONE PIECE MAT; NO JOINTS
- 1/4" THICK VIRGIN RUBBER COMPOUND WITH CHECKER-PLATE BAR TOP SURFACE
- TEAR RESISTANT
- CHEMICAL/MOISTURE RESISTANT
- VIRTUALLY ODOUR-FREE
- EASY TO CLEAN

STOCKED AT ALL  
WAREHOUSES



# AUTOMAT-BAR SPECIFICATIONS

MAKE & MODEL	PART #	PCS	WEIGHT	INSTALL
				
Transit Connect (105") SWB	711-043-7021	1 pc	26 lbs	8 mins
Transit Connect (121") LWB	721-043-7521	1 pc	34 lbs	8 mins
Transit Connect LWB Dual Sliding Doors	721-043-7521.2	1 pc	34 lbs	8 mins
Transit 130" WB	731-043-7621	1 pc	56 lbs	10 mins
Transit 130" WB Dual Sliding Doors	731-043-7621.2	1 pc	56 lbs	10 mins
Transit 130" WB Crew	73C1-043-7621	1 pc	56 lbs	10 mins
Transit 148" WB	741-043-7321	1 pc	66 lbs	10 mins
Transit 148" WB Dual Sliding Doors	741-043-7321.2	1 pc	66 lbs	10 mins
Transit 148" WB Crew	74C1-043-7321	1 pc	66 lbs	10 mins
Transit 148" Extended WB	751-043-7021	1 pc	83 lbs	10 mins
Transit 148" Ext. WB Dual Sliding Doors	751-043-7021.2	1 pc	83 lbs	10 mins
Transit 148" Extended WB Crew	75C1-043-7021	1 pc	83 lbs	10 mins

For the Transit Connect LWB, please use product extension .U (United States) or .C (Canada) for your country, as there are some design differences.



## Mercedes-Benz

Metris (126") RWB	151-043-7621	1 pc	67 lbs	15 mins
Metris RWB Dual Sliding Doors	151-043-7621.2	1 pc	67 lbs	15 mins
Metris (135") EWB	111-043-7621	1 pc	70 lbs	15 mins
Metris EWB Dual Sliding Doors	111-043-7621	1 pc	70 lbs	15 mins
Sprinter 144" WB	121-043-7021	1 pc	66 lbs	10 mins
Sprinter 144" WB Dual Sliding Doors	121-043-7021.2	1 pc	66 lbs	10 mins
Sprinter 144" WB Crew	12C1-043-7321	1 pc	64 lbs	10 mins
Sprinter 170" Standard WB	131-043-7021	1 pc	90 lbs	12 mins
Sprinter 170" WB Dual Sliding Doors	131-043-7021.2	1 pc	90 lbs	12 mins
Sprinter 170" Standard WB Crew	13C1-043-7021	1 pc	88 lbs	12 mins
Sprinter 170" Extended WB	141-043-7021	1 pc	100 lbs	15 mins
Sprinter 170" Ext. WB Dual Sliding Doors	141-043-7021.2	1 pc	100 lbs	15 mins
Sprinter 170" Extended WB Crew	14C1-043-7021	1 pc	97 lbs	15 mins

## Additional Product Extensions

Please specify vehicle model year when ordering.

- |                               |  |
|-------------------------------|--|
| .1 Dual Wheels                | .8 Super Single and Dual Sliding Doors |
| .2 Dual Side Sliding Doors    | .9 Dual Wheels and OEM Trim            |
| .4 with OEM doorway step trim | .N No Side Doors                       |
| .5 Dual Doors and Dual Wheels | .A Rear AC                             |
| .6 Super Single Rear Wheels   | .H Handbrake console cutout            |

**ALL FLOORS INCLUDE SIDE AND REAR ALUMINIUM SILL PLATES.  
ALL CREW FLOORS INCLUDE THE REAR ALUMINIUM SILL PLATE ONLY.**

MAKE & MODEL	PART #	PCS	WEIGHT	INSTALL
				
C/V Tradesman* (119" WB) Chrysler Pacifica*	612-043-7521 692-043-7521	1 pc 1 pc	36 lbs 36 lbs	10 mins 10 mins
Promaster City (122" WB)	671-043-7521	1 pc	34 lbs	10 mins
ProMaster 118" WB ProMaster 118" WB Crew	621-043-7621 62C1-043-7621	1 pc 1 pc	56 lbs 54 lbs	15 mins 15 mins
ProMaster 136" WB ProMaster 136" WB Dual Sliding Doors ProMaster 136" WB Crew	631-043-7621 631-043-7621.2 63C1-043-7621	1 pc 1 pc 1 pc	67 lbs 67 lbs 64 lbs	15 mins 15 mins 15 mins
ProMaster 159" WB ProMaster 159" WB Dual Sliding Doors ProMaster 159" WB Crew	641-043-7321 641-043-7321.2 64C1-043-7321	1 pc 1 pc 1 pc	81 lbs 81 lbs 79 lbs	20 mins 20 mins 20 mins
ProMaster 159" Extended WB ProMaster 159" Ext. WB Dual Sliding Doors ProMaster 159" Extended WB Crew	651-043-7021 651-043-7021.2 65C1-043-7021	1 pc 1 pc 1 pc	85 lbs 85 lbs 82 lbs	20 mins 20 mins 20 mins

For the ProMaster City, please use product extension .U (United States) or .C (Canada) for your country, as there are some design differences.  
Also please specify vehicle model year when ordering.



Chevy City Express (115") WB	361-043-7521	1 pc	31 lbs	10 mins
GMC Savana/ Chevy Express Regular (135") WB	311-043-7621	1 pc	56 lbs	10 mins
GMC Savana/ Chevy Express Extended (155") WB	321-043-7321	1 pc	68 lbs	10 mins



NV 200 (115" WB)	531-043-7521	1 pc	31 lbs	20 mins
NV Cargo (140" WB)	511-043-7621	1 pc	58 lbs	20 mins

Floor info: pcs, weight, and install time doesn't include the sill set. Refer to page 54 for sill set information.

\*There are currently no sills available for C/V Tradesman or Chrysler Pacifica



# TRUCK BED AUTOMAT-BAR RUBBER MAT

## PROTECT SURFACE

- Save your truck bed from scratches, dents, and damage to resale value.
- 1/4" thick rubber mat is durable, heavy-duty and long-lasting.
- Can be used across any industry. Resistant to chemicals and oils. Odour-free. Waterproof. Easy to clean.

## TRACTION AND GRIP

- Ultra non-slip rubber with checker plate surface is ideal where extra traction and safety is needed.
- Decrease chances of trips, slips, and falls.
- Cargo will stay in place rather than shifting around as it would on smooth slippery steel surface.

## PRECISION CUT

- Cut to fit each specific truck bed perfectly.
- One-piece mat makes for less than a minute install/removal.
- Custom sizing available on request.



**NOW AVAILABLE FOR ALL CURRENT MODEL YEAR FORD, RAM, AND GMC FULL SIZE PICK-UP TRUCKS.**

For vehicles not mentioned below, please call or email [info@legendfleet.com](mailto:info@legendfleet.com).

MAKE & MODEL	BOX	PART #	WEIGHT	INSTALL
Ford F-150	5.5'	TF1-043-01	31 lbs	5 mins
Ford F-150	6.5'	TF2-043-01	37 lbs	5 mins
Ford F-150	8'	TF3-043-01	47 lbs	5 mins
Ford F-250	6.5'	TF2-043-02	40 lbs	5 mins
Ford F-250	8'	TF3-043-02	49 lbs	5 mins
Ford Ranger	5'	TF1-043-05	32 lbs	5 mins
Ford Ranger	6'	TF2-043-05	32 lbs	5 mins
GMC Canyon/Canyon Denali/ Chevy Colorado	5'	TG1-043-09	35 lbs	5 mins
GMC Canyon/Canyon Denali/ Chevy Colorado	6'	TG2-043-09	41 lbs	5 mins
GMC Sierra 1500/1500 Denali/ Chevy Silverado 1500	5.75'	TG1-043-06	35 lbs	5 mins
GMC Sierra 1500/1500 Denali/ Chevy Silverado 1500	6.75'	TG2-043-06	41 lbs	5 mins
GMC Sierra 1500/1500 Denali/ Chevy Silverado 1500	8'	TG3-043-06	52 lbs	5 mins
GMC Sierra 2500HD/2500HD Denali/ Chevy Silverado 2500HD	6.75'	TG2-043-07	41 lbs	5 mins
GMC Sierra 2500HD/2500HD Denali/ Chevy Silverado 2500HD	8'	TG3-043-07	52 lbs	5 mins
GMC Sierra 3500HD/3500HD Denali/ Chevy Silverado 3500HD	6.75'	TG2-043-08	41 lbs	5 mins
GMC Sierra 3500HD/3500HD Denali/ Chevy Silverado 3500HD	8'	TG3-043-08	52 lbs	5 mins
RAM	5.6'	TR1-043-10	31 lbs	5 mins
RAM Classic	5.6'	TR1-043-11	31 lbs	5 mins
RAM	6.3'	TR2-043-10	36 lbs	5 mins
RAM Classic	6.3'	TR2-043-11	36 lbs	5 mins
RAM	8'	TR3-043-10	47 lbs	5 mins
RAM Classic	8'	TR3-043-11	47 lbs	5 mins

Additional Product Extensions

.1 dual rear wheels

.2 RamBox configuration



# DURATHERM INSULATED WALL LINERS



SEAMLESS  
LARGE PANEL  
DESIGN

These industry-leading wall liners are highly durable, impact resistant, and will protect cargo van panels from the harshest wear and tear. These liners' insulation deadens sound significantly to enhance operator workspaces, while creating a thermal barrier to control temperatures. These competitively priced wall liners provide superb side panel protection to increase the lifespan and resale value of the vehicle.

- SOUND DEADENING
- IMPACT / PUNCTURE RESISTANT
- LIGHTWEIGHT & EASY TO INSTALL
- PRECISION CUT TO FIT VEHICLE
- THERMAL BARRIER - LAYER OF INSULATION
- TEXTURED SURFACE FOR ULTIMATE SCRATCH RESISTANCE
- PROFESSIONAL BRAND IMAGE
- AVAILABLE IN WHITE AND GREY

STOCKED AT ALL  
WAREHOUSES



# WALL LINER SPECIFICATIONS

MAKE & MODEL	PART #	COLOUR	WEIGHT	INSTALL
 Transit Connect (105") SWB	714-114-2613	Grey	18 lbs	30 mins
	714-114-2614	White	18 lbs	30 mins
Transit Connect (121") LWB	724-114-2613	Grey	18 lbs	30 mins
	724-114-2614	White	18 lbs	30 mins
Transit 130" WB Low Roof	734-114-2613.LR	Grey	25 lbs	45 mins
	734-114-2614.LR	White	25 lbs	45 mins
Transit 130" WB Low Roof Crew	73C4-114-2613.LR	Grey	22 lbs	45 mins
	73C4-114-2614.LR	White	22 lbs	45 mins
Transit 130" WB Mid Roof	734-114-2613.MR	Grey	30 lbs	45 mins
	734-114-2614.MR	White	30 lbs	45 mins
Transit 130" WB Mid Roof Crew	73C4-114-2613.MR	Grey	30 lbs	45 mins
	73C4-114-2614.MR	White	30 lbs	45 mins
Transit 148" WB Low Roof	744-114-2613.LR	Grey	31 lbs	45 mins
	744-114-2614.LR	White	31 lbs	45 mins
Transit 148" WB Low Roof Crew	74C4-114-2613.LR	Grey	30 lbs	45 mins
	74C4-114-2614.LR	White	30 lbs	45 mins
Transit 148" WB Mid Roof	744-114-2613.MR	Grey	39 lbs	75 mins
	744-114-2614.MR	White	39 lbs	75 mins
Transit 148" WB Mid Roof Crew	74C4-114-2613.MR	Grey	36 lbs	75 mins
	74C4-114-2614.MR	White	36 lbs	75 mins
Transit 148" WB High Roof	744-114-2613.HR	Grey	60 lbs	75 mins
	744-114-2614.HR	White	60 lbs	75 mins
Transit 148" WB High Roof Crew	74C4-114-2613.HR	Grey	38 lbs	75 mins
	74C4-114-2614.HR	White	38 lbs	75 mins
Transit 148" Extended WB	754-114-2613	Grey	44 lbs	80 mins
	754-114-2614	White	44 lbs	80 mins
Transit 148" WB Ext. WB Crew	75C4-114-2613	Grey	44 lbs	75 mins
	75C4-114-2614	White	44 lbs	75 mins



NV 200 (115" WB)	534-114-2613	Grey	9 lbs	30 mins
	534-114-2614	White	9 lbs	30 mins
NV Cargo (140" WB) Low Roof	514-114-2613	Grey	23 lbs	60 mins
	514-114-2614	White	23 lbs	60 mins
NV Cargo (140" WB) High Roof	524-114-2613	Grey	33 lbs	60 mins
	524-114-2614	White	33 lbs	60 mins

Additional Product Extensions / Info  
.2 dual sliding doors

MAKE & MODEL	PART #	COLOUR	WEIGHT	INSTALL	RETAIL
 Promaster City (122" WB)	674-114-2613	Grey	10 lbs	45 mins	
	674-114-2614	White	10 lbs	45 mins	
ProMaster 118" WB	624-114-2613	Grey	30 lbs	60 mins	
	624-114-2614	White	30 lbs	60 mins	
ProMaster 118" WB Crew	62C4-114-2613	Grey	24 lbs	60 mins	
	62C4-114-2614	White	24 lbs	60 mins	
ProMaster 136" WB Low Roof	634-114-2613.LR	Grey	29 lbs	60 mins	
	634-114-2614.LR	White	29 lbs	60 mins	
ProMaster 136" WB LR Crew	63C4-114-2613.LR	Grey	26 lbs	60 mins	
	63C4-114-2614.LR	White	26 lbs	60 mins	
ProMaster 136" WB High Roof	634-114-2613.HR	Grey	34 lbs	60 mins	
	634-114-2614.HR	White	34 lbs	60 mins	
ProMaster 136" WB HR Crew	63C4-114-2613.HR	Grey	30 lbs	60 mins	
	63C4-114-2614.HR	White	30 lbs	60 mins	
ProMaster 159" WB	644-114-2613	Grey	45 lbs	60 mins	
	644-114-2614	White	45 lbs	60 mins	
ProMaster 159" WB Crew	64C4-114-2613	Grey	38 lbs	60 mins	
	64C4-114-2614	White	38 lbs	60 mins	
ProMaster 159" Extended WB	654-114-2613	Grey	52 lbs	75 mins	
	654-114-2614	White	52 lbs	75 mins	
ProMaster 159" Ext. WB Crew	65C4-114-2613	Grey	42 lbs	75 mins	
	65C4-114-2614	White	42 lbs	75 mins	



Chevy City Express (115") WB	364-114-2613	Grey	15 lbs	30 mins	
	364-114-2614	White	15 lbs	30 mins	
GMC Regular (135") WB	314-114-2613	Grey	25 lbs	60 mins	
	314-114-2614	White	25 lbs	60 mins	
GMC Extended (155") WB	324-114-2613	Grey	30 lbs	60 mins	
	324-114-2614	Grey	30 lbs	60 mins	

## Additional Product Extensions

- .2 Dual Sliding Doors
- .5 Dual Doors and Dual Wheels
- .8 Super Single and Dual Sliding Doors
- .9 Dual Wheels and OEM Trim
- .N No Side Doors



# WALL LINER SPECIFICATIONS

MAKE & MODEL	PART #	COLOUR	WEIGHT	INSTALL
 <p>Mercedes-Benz</p>				
Mercedes Metris (126") RWB	154-114-2613	Grey	22 lbs	35 mins
	154-114-2614	White	22 lbs	35 mins
Mercedes Metris (135") EWB	114-114-2613	Grey	25 lbs	35 mins
	114-114-2614	White	25 lbs	35 mins
Sprinter 144" WB Low Roof	124-114-2613.LR	Grey	36 lbs	45 mins
	124-114-2614.LR	White	36 lbs	45 mins
Sprinter 144" WB Low Roof Crew	12C4-114-2613.LR	Grey	30 lbs	45 mins
	12C4-114-2614.LR	White	30 lbs	45 mins
Sprinter 144" WB High Roof	124-114-2613.HR	Grey	43 lbs	60 mins
	124-114-2614.HR	White	43 lbs	60 mins
Sprinter 144" WB High Roof Crew	12C4-114-2613.HR	Grey	36 lbs	60 mins
	12C4-114-2614.HR	White	36 lbs	60 mins
Sprinter 170" WB	134-114-2613	Grey	53 lbs	75 mins
	134-114-2614	White	53 lbs	75 mins
Sprinter 170" WB Crew	13C4-114-2613.HR	Grey	46 lbs	75 mins
	13C4-114-2614.HR	White	46 lbs	75 mins
Sprinter 170" Extended WB	144-114-2613	Grey	70 lbs	90 mins
	144-114-2614	White	70 lbs	90 mins
Sprinter 170" Ext. WB Crew	14C4-114-2613.HR	Grey	52 lbs	90 mins
	14C4-114-2614.HR	White	52 lbs	90 mins

## Additional Product Extensions

- .2 Dual Sliding Doors
- .5 Dual Doors and Dual Wheels
- .8 Super Single and Dual Sliding Doors
- .9 Dual Wheels and OEM Trim
- .N No Side Doors

**THESE  
LEGENDARY  
LINERS ARE  
FIELD PROVEN  
ACROSS MANY  
INDUSTRIES**



# DURATHERM INSULATED CEILING LINERS

Ceiling Liners finish an interior protection package by creating a complete sound-deadening and thermal barrier. Without these there is no temperature control in cargo vans. Creating a finished professional appearance with the joining top sills also enhances your brand image, since the ceiling is highly visible from the exterior of the vehicle when doors are open.

- SOUND DEADENING
- IMPACT / PUNCTURE RESISTANT
- INCREASES RESALE VALUE
- PROTECTS INTERIOR
- THERMAL BARRIER
- JOINING ALUMINIUM TOP SILLS INCLUDED
- AVAILABLE IN WHITE AND GREY

STOCKED AT ALL  
WAREHOUSES



# CEILING LINER SPECIFICATIONS

MAKE & MODEL	PART #	COLOUR	WEIGHT	INSTALL	
	Transit Connect (105") SWB	715-114-2613	Grey	18 lbs	30 mins
		715-114-2614	White	18 lbs	30 mins
Transit Connect (121") LWB	725-114-2613	Grey	18 lbs	45 mins	
	725-114-2614	White	18 lbs	45 mins	
Transit 130" WB Low Roof	735-114-2613.LR	Grey	19 lbs	60 mins	
	735-114-2614.LR	White	19 lbs	60 mins	
Transit 130" WB Low Roof Crew	73C5-114-2613.LR	Grey	18 lbs	60 mins	
	73C5-114-2614.LR	White	18 lbs	60 mins	
Transit 130" WB Mid Roof	735-114-2613.MR	Grey	21 lbs	60 mins	
	735-114-2614.MR	White	21 lbs	60 mins	
Transit 130" WB Mid Roof Crew	73C5-114-2613.MR	Grey	19 lbs	60 mins	
	73C5-114-2614.MR	White	19 lbs	60 mins	
Transit 148" WB Low Roof	745-114-2613.LR	Grey	23 lbs	60 mins	
	745-114-2614.LR	White	23 lbs	60 mins	
Transit 148" WB Low Roof Crew	74C5-114-2613.LR	Grey	20 lbs	60 mins	
	74C5-114-2614.LR	White	20 lbs	60 mins	
Transit 148" WB Mid Roof	745-114-2613.MR	Grey	24 lbs	60 mins	
	745-114-2614.MR	White	24 lbs	60 mins	
Transit 148" WB Mid Roof Crew	74C5-114-2613.MR	Grey	21 lbs	60 mins	
	74C5-114-2614.MR	White	21 lbs	60 mins	
Transit 148" WB High Roof	745-114-2613.HR	Grey	24 lbs	60 mins	
	745-114-2614.HR	White	24 lbs	60 mins	
Transit 148" WB High Roof Crew	74C5-114-2613.HR	Grey	21 lbs	60 mins	
	74C5-114-2614.HR	White	21 lbs	60 mins	
Transit 148" Extended WB	755-114-2613	Grey	30 lbs	60 mins	
	755-114-2614	White	30 lbs	60 mins	
Transit 148" Extended WB Crew	75C5-114-2613	Grey	28 lbs	60 mins	
	75C5-114-2614	White	28 lbs	60 mins	



NV 200 (115" WB)	535-114-2613	Grey	20	30 mins
	535-114-2614	White	20	30 mins
NV Cargo (140" WB) Low Roof	515-114-2613	Grey	21	45 mins
	515-114-2614	White	21	45 mins
NV Cargo (140" WB) High Roof	525-114-2613	Grey	20	60 mins
	525-114-2614	White	20	60 mins

Additional Product Extensions / Info  
.2 dual sliding doors

MAKE & MODEL	PART #	COLOUR	WEIGHT	INSTALL	
	ProMaster City (122" WB)	675-114-2613	Grey	12 lbs	30 mins
		675-114-2614	White	12 lbs	30 mins
ProMaster 118" WB	625-114-2613	Grey	18 lbs	45 mins	
	625-114-2614	White	18 lbs	45 mins	
ProMaster 118" WB Crew	62C5-114-2613	Grey	16 lbs	45 mins	
	62C5-114-2614	White	16 lbs	45 mins	
ProMaster 136" WB Low Roof	635-114-2613.LR	Grey	22 lbs	45 mins	
	635-114-2614.LR	White	22 lbs	45 mins	
ProMaster 136" WB LR Crew	63C5-114-2613.LR	Grey	20 lbs	45 mins	
	63C5-114-2614.LR	White	20 lbs	45 mins	
ProMaster 136" WB High Roof	635-114-2613.HR	Grey	23 lbs	45 mins	
	635-114-2614.HR	White	23 lbs	45 mins	
ProMaster 136" WB HR Crew	63C5-114-2613.HR	Grey	20 lbs	45 mins	
	63C5-114-2614.HR	White	20 lbs	45 mins	
ProMaster 159" WB	645-114-2613	Grey	26 lbs	60 mins	
	645-114-2614	White	26 lbs	60 mins	
ProMaster 159" WB Crew	64C5-114-2613	Grey	23 lbs	60 mins	
	64C5-114-2614	White	23 lbs	60 mins	
ProMaster 159" Extended WB	655-114-2613	Grey	28 lbs	60 mins	
	655-114-2614	White	28 lbs	60 mins	
ProMaster 159" Ext. WB Crew	65C5-114-2613	Grey	24 lbs	60 mins	
	65C5-114-2614	White	24 lbs	60 mins	



Chevy City Express (115") WB	365-114-2613	Grey	37 lbs	30 mins
	365-114-2614	White	37 lbs	30 mins
GMC Regular (135") WB	315-114-2613	Grey	19 lbs	45 mins
	315-114-2614	White	19 lbs	45 mins
GMC Extended (155") WB	325-114-2613	Grey	30 lbs	60 mins
	325-114-2614	Grey	30 lbs	60 mins

## Additional Product Extensions

.2 Dual Sliding Doors  
.5 Dual Doors and Dual Wheels  
.N No Side Doors



# CEILING LINER SPECIFICATIONS

MAKE & MODEL	PART #	COLOUR	WEIGHT	INSTALL	
 Mercedes-Benz	Mercedes Metris (126") RWB	155-114-2613	Grey	16 lbs	30 mins
		155-114-2614	White	16 lbs	30 mins
Mercedes Metris (135") EWB	115-114-2613	Grey	18 lbs	30 mins	
	115-114-2614	White	18 lbs	30 mins	
Sprinter 144" WB Low Roof	125-114-2613.LR	Grey	25 lbs	45 mins	
	125-114-2614.LR	White	25 lbs	45 mins	
Sprinter 144" WB High Roof	125-114-2613.HR	Grey	25 lbs	45 mins	
	125-114-2614.HR	White	25 lbs	45 mins	
Sprinter 170" WB	135-114-2613	Grey	29 lbs	60 mins	
	135-114-2614	White	29 lbs	60 mins	
Sprinter 170" Extended WB	145-114-2613	Grey	32 lbs	60 mins	
	145-114-2614	White	32 lbs	60 mins	

## Additional Product Extensions

- .2 Dual Sliding Doors
- .5 Dual Doors and Dual Wheels
- .N No Side Doors





# DURATHERM INSULATED DOOR LINERS

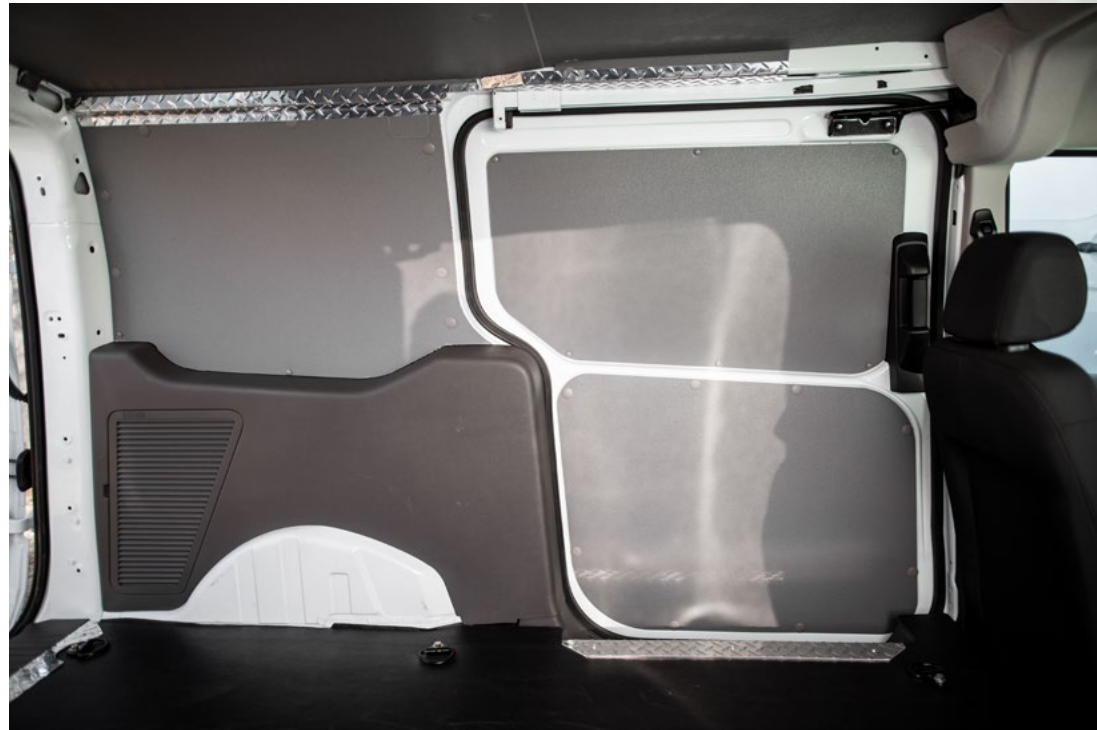

Insulated DuraTherm Door Liners add extra protection, insulation and sound-deadening in the vehicle. The door liners protect the sheet metal or the glass in the window cavities from moving objects inside the van that could potentially cause damage such as dents or broken windows.

- SOUND DEADENING
- SUPERIOR IMPACT / PUNCTURE RESISTANCE
- INCREASES RESALE VALUE
- PROTECTS VAN PANELS FROM DAMAGE
- THERMAL BARRIER TO CONTROL TEMPERATURE
- PRE-DRILLED FOR EASY INSTALL, INCLUDES PUSH-IN RIVETS
- AVAILABLE IN WHITE AND GREY

STOCKED AT ALL  
WAREHOUSES



# DOOR LINER SPECIFICATIONS

Please note: dual sliding door kits are found at the bottom of each OEM section.

MAKE & MODEL	PART #	COLOUR	WEIGHT	INSTALL
 Transit Connect (105") SWB	713-114-2613	Grey	10 lbs	15 mins
	713-114-2614	White	10 lbs	15 mins
Transit Connect (121") LWB	723-114-2613	Grey	10 lbs	15 mins
	723-114-2614	White	10 lbs	15 mins
Transit Low Roof (add .3 for barn doors) Transit Low Roof Crew	703-114-2613.LR	Grey	13 lbs	15 mins
	703-114-2614.LR	White	13 lbs	15 mins
	70C3-114-2613.LR	Grey	10 lbs	15 mins
	70C3-114-2614.LR	White	10 lbs	15 mins
Transit Mid Roof	703-114-2613.MR	Grey	18 lbs	15 mins
	703-114-2614.MR	White	18 lbs	15 mins
Transit Mid Roof Crew	70C3-114-2613.MR	Grey	12 lbs	15 mins
	70C3-114-2614.MR	White	12 lbs	15 mins
Transit High Roof	703-114-2613.HR	Grey	20 lbs	15 mins
	703-114-2614.HR	White	20 lbs	15 mins
Transit High Roof Crew	70C3-114-2613.HR	Grey	12 lbs	15 mins
Transit MR Dual Sliding Door (for 130" or 148")	703-114-2613.MR.2	Grey	21 lbs	25 mins
Transit HR Dual Sliding Door (for 148 or 148X")	703-114-2613.HR.2	Grey	22 lbs	25 mins



NV 200 (115" WB)	533-114-2613	Grey	8 lbs	15 mins
	533-114-2614	White	8 lbs	15 mins
NV Cargo (140" WB) Low Roof	513-114-2613	Grey	11 lbs	15 mins
	513-114-2614	White	11 lbs	15 mins
NV Cargo (140" WB) High Roof	523-114-2613	Grey	17 lbs	15 mins
	523-114-2614	White	17 lbs	15 mins



Chevy City Express (115") WB	363-114-2613	Grey	10 lbs	15 mins
	363-114-2614	White	10 lbs	15 mins
GMC Savana RWB & EWB	303-114-2613	Grey	10 lbs	15 mins
	303-114-2614	White	10 lbs	15 mins

## Additional Product Extensions / Info

Crew Van Door Liner Kits only include panels for the rear doors.

.3 Hinged Side Doors

.5 Dual Doors and Dual Wheels

.7 Rear Liftgate

.8 Super Single and Dual Sliding Doors

.N No Side Doors

MAKE & MODEL	PART #	COLOUR	WEIGHT	INSTALL
 Promaster City (122" WB)	673-114-2613	Grey	7 lbs	15 mins
	673-114-2614	White	7 lbs	15 mins
Promaster 118" WB	623-114-2613	Grey	18 lbs	15 mins
ProMaster 118" WB Crew	623-114-2614	White	18 lbs	15 mins
	62C3-114-2613	Grey	10 lbs	15 mins
Promaster Low Roof	62C3-114-2614	White	10 lbs	15 mins
	603-114-2613.LR	Grey	18 lbs	15 mins
ProMaster Low Roof Crew	603-114-2614.LR	White	18 lbs	15 mins
	60C3-114-2613.LR	Grey	10 lbs	15 mins
Promaster High Roof	60C3-114-2614.LR	White	10 lbs	15 mins
	603-114-2613.HR	Grey	23 lbs	15 mins
ProMaster High Roof Crew	603-114-2614.HR	White	23 lbs	15 mins
	60C3-114-2613.HR	Grey	12 lbs	15 mins
ProMaster High Roof Crew	60C3-114-2614.HR	White	12 lbs	15 mins
	603-114-2613.LR.2	Grey	22 lbs	20 mins
ProMaster LR Dual Sliding Door (for 136")	603-114-2613.LR.2	Grey	22 lbs	20 mins
ProMaster HR Dual Sliding Door (for 136", 159", or 159X")	603-114-2613.HR.2	Grey	23 lbs	25 mins



## Mercedes-Benz

Mercedes Metris (126") RWB	153-114-2613	Grey	13 lbs	15 mins
	153-114-2614	White	13 lbs	15 mins
Mercedes Metris (135") EWB	113-114-2613	Grey	13 lbs	15 mins
	113-114-2614	White	13 lbs	15 mins
Sprinter Low Roof	103-114-2613.LR	Grey	20 lbs	15 mins
	103-114-2614.LR	White	20 lbs	15 mins
Sprinter Low Roof Crew	10C3-114-2613.LR	Grey	18 lbs	15 mins
	10C3-114-2613.HR	White	18 lbs	15 mins
Sprinter High Roof	103-114-2613.HR	Grey	23 lbs	15 mins
	103-114-2614.HR	White	23 lbs	15 mins
Sprinter High Roof Crew	10C3-114-2613.HR	Grey	20 lbs	15 mins
	10C3-114-2614.HR	White	20 lbs	15 mins
Metris RWB Dual Sliding Door	153-114-2613.2	Grey	15 lbs	20 mins
Metris EWB Dual Sliding Door	113-114-2613.2	Grey	17 lbs	25 mins
Sprinter LR Dual Sliding Door (for 144")	103-114-2613.LR.2	Grey	24 lbs	25 mins
Sprinter HR Dual Sliding Door (for 144", 170", or 170X")	103-114-2613.HR.2	Grey	25 lbs	25 mins



# WHEEL WELL COVERS



**Protection:** Covers allow full protection of all bare metal panels. In a cargo van, the wheel wells are one of the first things to dent and damage quickly, because of cargo loading in and out.

**Decrease Road Noise:** significantly deaden loud wheel and road noise by closing in wheel wells with extra padding.

**Thermal Barrier:** with layers of insulation, wheel well covers complete the insulation of the van's interiors.

**Professional Appearance:** enhance your brand and mobile workforce appearance.

MAKE & MODEL

PART #

WEIGHT

INSTALL



Transit Wheel Well Cover Set - Black

7-WWC-11

7 lbs

10 mins



**RAM**

ProMaster Wheel Well Cover Set - Black

6-WWC-11

9 lbs

10 mins



Mercedes-Benz

Sprinter Wheel Well Cover Set - Black

1-WWC-11

7 lbs

10 mins

Single Rear Wheels Configuration only. Dual Rear Wheels/Super Single Rear Wheels Configurations for Wheel Well Covers are not available.



TRANSIT



PROMASTER



SPRINTER

STOCKED AT ALL  
WAREHOUSES



**SAFETY FIRST**

# ALUMINIUM SIDE AND REAR SILL SET

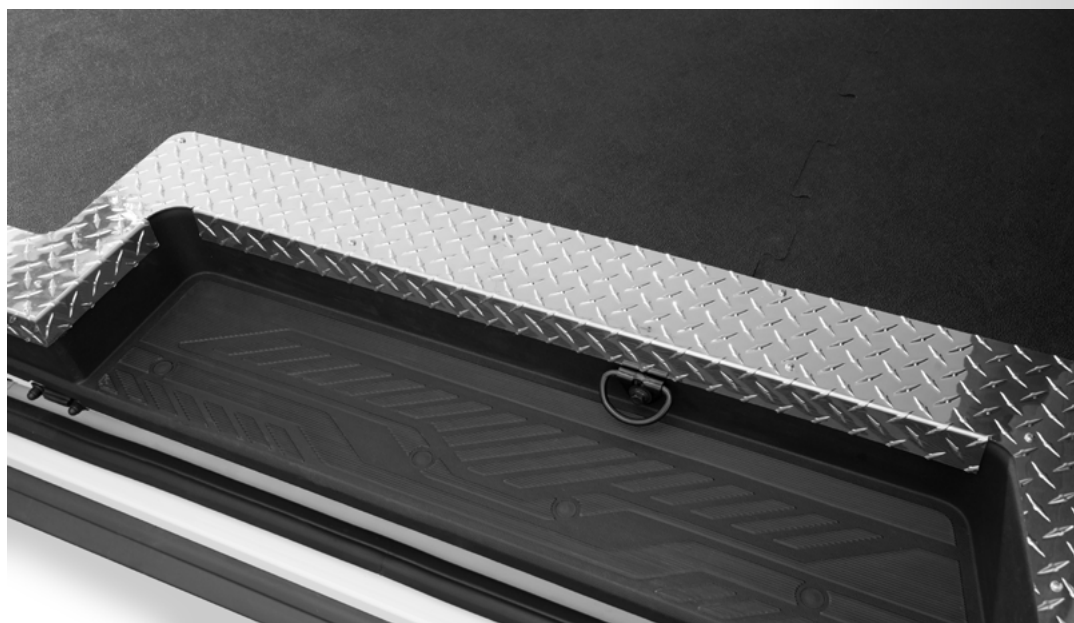

Side and rear sills are used to protect the floor at the side and rear entrance to the cargo van where traffic is the highest. Made from high-grade aluminum, these sills are good for any application, especially when loading with a forklift. A raised finish also ensures excellent grip.

- MAXIMIZE PROTECTION FOR HIGHEST TRAFFIC AREAS
- ALUMINIUM CHECKER PLATE FOR HIGH GRIP/WEAR
- CUSTOM CUT AND FORMED EDGE PROTECTION
- PROFESSIONAL FINISH
- SOLD AS SET (REAR AND SIDE)

STOCKED AT ALL  
WAREHOUSES



# SILL PLATES SPECIFICATIONS

MAKE & MODEL	PART #	WEIGHT	INSTALL
			
Transit Connect (105") SWB	719-151-1010 Side and Rear Sill Set	4 lbs	15 mins
Transit Connect (121") LWB	729-151-1010 Side Sill and Rear Sill Set	4 lbs	15 mins
Transit	709-151-1010 Side Sill and Rear Sill Set	6 lbs	10 mins
	709-151-1010.2 Dual Door Sill Set	9 lbs	15 mins



Mercedes Metris Sill Set	159-151-1010 Side and Rear Sill Set	6 lbs	10 mins
	159-151-1010.2 Dual Door Sill Set	9 lbs	15 mins
Mercedes Sprinter Sill Set	109-151-1010 Side and Rear Sill Set	6 lbs	10 mins
	109-151-1010.2 Dual Door Sill Set	9 lbs	15 mins



Promaster City (122" WB)	679-151-1010 Side and Rear Sill Set	13 lbs	20 mins
Promaster 118" WB	629-151-1010 Side and Rear Sill Set	4 lbs	10 mins
	629-151-1010.2 Dual Door Sill Set	6 lbs	15 mins
Promaster	609-151-1010 Side and Rear Sill Set	4 lbs	10 mins
	609-151-1010.2 Dual Door Sill Set	6 lbs	15 mins

MAKE & MODEL	PART #	WEIGHT	INSTALL
			
Chevy City Express (115") WB	369-151-1010 Side and Rear Sill Set	4 lbs	18 mins
GMC Savana RWB & EWB	309-151-1010 Side and Rear Sill Set	5 lbs	10 mins



NV 200 (115" WB)	539-151-1010 Side and Rear Sill Set	4 lbs	20 mins
NV Cargo LR & HR	009-151-1010 Side and Rear Sill Set	4 lbs	10 mins





# SIDE AND REAR STEEL THRESHOLDS

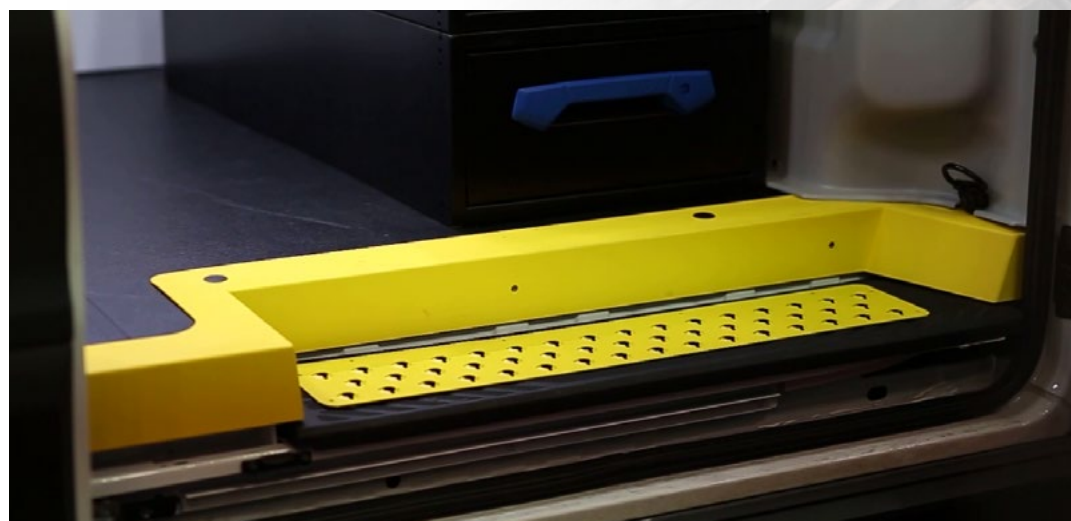
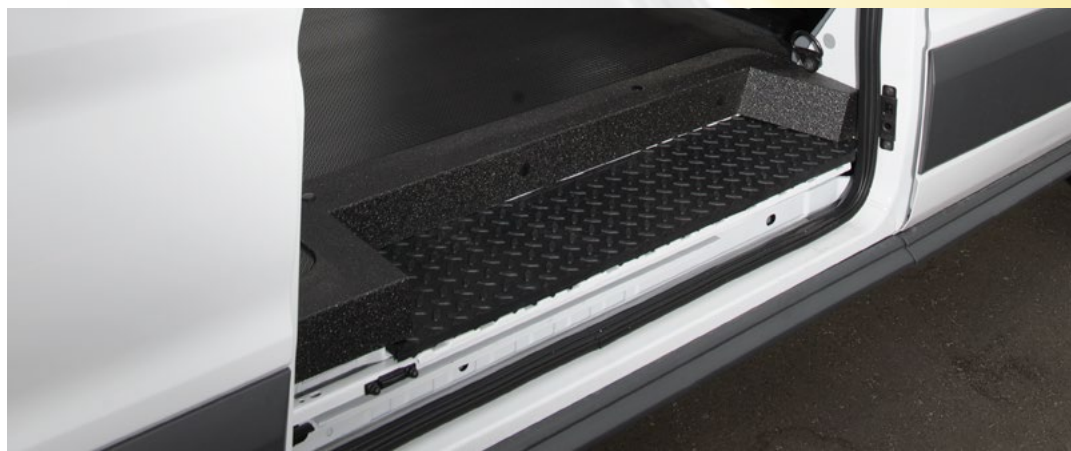

Treadplate is a separate part, see on next page

Transit doorway thresholds are made from 14 gauge steel with a special vacuumized coating that is both sturdy and non-slip. These are more durable than the standard factory fitted thresholds, helping to protect the entrance of Ford Transits.

- MAXIMIZED PROTECTION FOR HIGHEST TRAFFIC AREAS
- POWDER-COATED STEEL FOR HIGH GRIP/WEAR
- HEAVY DUTY, EXTREMELY DURABLE
- CUSTOM CUT AND FORMED EDGE PROTECTION
- PROFESSIONAL FINISH

**STOCKED AT ALL WAREHOUSES**

MAKE & MODEL

PART #

WEIGHT

INSTALL



Transit Side & Rear Threshold Set - Black	709-151-1011	22 lbs	15 mins
Transit Dual Side & Rear Threshold Set - Black	709-151-1011.2	35 lbs	20 mins
Transit Side & Rear Threshold Set - Yellow	709-151-1018	22 lbs	15 mins
Transit Dual Side & Rear Threshold Set - Yellow	709-151-1018.2	35 lbs	20 mins





**SAFETY FIRST**

# SECURIGRIP

## HIGH VISIBILITY STEEL SAFETY ACCESSORIES

- Increase safety for operators
- Increase efficiency by allowing operators to load in and out quickly/in all weather conditions
- Make brand statement with custom colour coating (available for fleets)

## TREAD PLATES

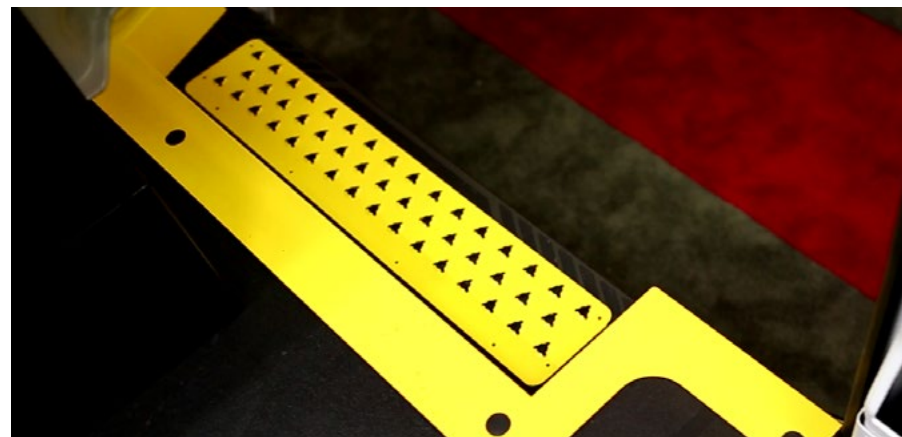

Approx. Dimensions:  
33 x 6"  
Part Number:  
006-047-1018

## GRAB HANDLES



**PROMASTER**  
11R00-40



**TRANSIT**  
11F00-40





**SAFETY FIRST**

# MOBILE HANDWASHING STATION SHOULDERSINK



Keep your drivers cleaner and safer while working hard on the road. Allow your mobile workforce to clean their hands after visiting any places of possible virus contamination.

- **Save Time:** Always ready to use. Lower the hose with your arm, and your hands are clean in just 30 seconds.
- **Stay Clean:** All-in-one mobile handwashing station: water, soap, hand sanitizer, paper towel, and garbage bin in one compact unit.
- **Stay Safe:** Simple hand-hygiene at every stop can help slow the spread of germs and viruses.

PART NUMBER: HS1-001

ON THE JOB, RIGHT WHERE YOU NEED IT



# KEEPING YOUR DRIVERS SAFE FIRST AID KITS



KIT INCLUDES:



**SUPA-BOND™**  
PROPRIETARY ADVANCED  
ADHESIVE PERFORMANCE



**TOTAL  
109  
PIECES**

## FIRST AID KIT (& RE-FILL KIT) INCLUDES:

SureFill® First Aid 25 Series Kits have been designed to cater for small mobile workspaces and includes quality first aid products required to treat injured workers so they are able to return to the job. These durable cases ensure contents are protected from the day to day exposure to dust and damage.

25 SERIES FIRST AID KIT With Plastic Retail Case  
25 SERIES FIRST AID KIT REFILL – Class A Only

SF1-017-105  
SF1-017-100

AeroBand™ Triangular Bandage	1	AeroPad™ Gauze Pad	2
AeroBurn™ Burn Gel Packets	10	AeroPlast™ Plastic Strip Bandage	25
AeroBurn™ Burn Dressing	1	AeroPlast™ Adhesive Tape	1
AeroCleanse™ Hand Sanitizer	10	AeroPlast™ Instant Ice Pack	1
AeroForm™ Conforming Gauze Bandage	1	AeroShield™ CPR Face Shield	1
AeroGlove™ Nitrile Gloves	4	AeroSoothe™ Triple Antibiotic	10
AeroGuide™ First Aid Guide	1	AeroSwab™ Cotton Tip Applicators	10
AeroInstrument™ Scissors	1	AeroWash™ Eyewash 1 fl. oz	1
AeroInstrument™ Tweezers	1	AeroWipe™ Antiseptic Wipes	20
AeroKit™ 25 Series Case	1	AeroWipe™ Alcohol Wipes	3
AeroPad™ Eye Pad	2	AeroWound™ Wound Pad	2



# ECONOLITE

BUDGET-FRIENDLY  
INTERIOR LINERS



Increase resale value with cost-effective protection. Where budget takes priority and protecting wall panels is a must. Adds value and safety to vans in your fleet.

#### EconoLite Wall and Door Liners

- 4mm thick polypropylene liners
- easy install with push-in rivets
- available in light grey
- budget-friendly for base protection

#### EconoMat - Rubber Mat

- 1/8" Economy Rubber Mat (sills not included)

#### EconoFloor - Rigid Floor

- 3/8" Economy Rigid Floor (sills not included)



# ECONOLITE WALL LINER

## SPECIFICATIONS

MAKE & MODEL	PART #	COLOUR	WEIGHT	INSTALL
				
Transit Connect (105") SWB	05F01-20	Light Grey	15 lbs	30 mins
Transit Connect (121") LWB	05F02-20	Light Grey	15 lbs	30 mins
Transit 130" Low Roof	05F03-20-L	Light Grey	24 lbs	45 mins
Transit 130" Mid Roof	05F03-20-M	Light Grey	26 lbs	45 mins
Transit 148" Low Roof	05F04-20-L	Light Grey	28 lbs	45 mins
Transit 148" Mid Roof	05F04-20-M	Light Grey	30 lbs	60 mins
Transit 148" High Roof	05F04-20-H	Light Grey	33 lbs	60 mins
Transit 148" Ext. WB	05F05-20	Light Grey	38 lbs	75 mins



### Mercedes-Benz

Metris (126") RWB	05M01-20	Light Grey	21 lbs	35 mins
Metris (135") EWB	05M05-20	Light Grey	24 lbs	35 mins
Sprinter 144" WB Low Roof	05M02-20-L	Light Grey	26 lbs	45 mins
Sprinter 144" WB High Roof	05M02-20-H	Light Grey	26 lbs	45 mins
Sprinter 170" WB	05M03-20	Light Grey	40 lbs	75 mins
Sprinter 170" Ext. WB	05M04-20	Light Grey	45 lbs	90 mins



Chevy City Express (115") WB	05G01-20	Light Grey	13 lbs	30 mins
GMC Savana RWB	05G02-20	Light Grey	22 lbs	60 mins
GMC Savana EWB	05G03-20	Light Grey	25 lbs	60 mins

MAKE & MODEL	PART #	COLOUR	WEIGHT	INSTALL
				
ProMaster City (122" WB)	05R01-20	Light Grey	20 lbs	45 mins
ProMaster 118" WB	05R02-20	Light Grey	25 lbs	60 mins
ProMaster 136" WB Low Roof	05R03-20-L	Light Grey	28 lbs	60 mins
ProMaster 136" WB High Roof	05R03-20-H	Light Grey	30 lbs	60 mins
ProMaster 159" WB	05R04-20	Light Grey	32 lbs	60 mins
ProMaster 159" Ext. WB	05R05-20	Light Grey	36 lbs	75 mins



NV 200 (115" WB)	05N01-20-H	Light Grey	13 lbs	30 mins
NV Cargo (140" WB) Low Roof	05N02-20-L	Light Grey	20 lbs	60 mins
NV Cargo (140" WB) High Roof	05N02-20-H	Light Grey	25 lbs	60 mins

### Additional Product Extensions

- .2 Dual Sliding Doors
- .5 Dual Doors and Dual Wheels
- .8 Super Single and Dual Sliding Doors
- .9 Dual Wheels and OEM Trim
- .N No Side Doors





# ECONOLITE DOOR LINER

## SPECIFICATIONS

MAKE & MODEL      PART #      COLOUR      WEIGHT      INSTALL



Transit Connect (105") SWB	07F01-20	Light Grey	8 lbs	15 mins
Transit Connect (121") LWB	07F02-20	Light Grey	8.5 lbs	15 mins
Transit Connect LWB Dual Sliding Doors	07F02-20.2	Light Grey	8.5 lbs	15 mins
Transit Low Roof	07F00-20-L	Light Grey	9 lbs	15 mins
Transit Mid Roof	07F00-20-M	Light Grey	10 lbs	15 mins
Transit Mid Roof Dual Sliding Doors	07F00-20-M.2	Light Grey	10 lbs	15 mins
Transit High Roof	07F00-20-H	Light Grey	10 lbs	15 mins
Transit High Roof Dual Sliding Doors	07F00-20-H.2	Light Grey	10 lbs	15 mins



### Mercedes-Benz

Metris (126") RWB	07M01-20	Light Grey	7 lbs	15 mins
Metris RWB Dual Sliding Doors	07M01-20.2	Light Grey	7 lbs	15 mins
Metris (135") EWB	07M05-20	Light Grey	7 lbs	35 mins
Metris EWB Dual Sliding Doors	07M05-20.2	Light Grey	7 lbs	35 mins
Sprinter Low Roof	07M00-20-L	Light Grey	11 lbs	15 mins
Sprinter Low Roof Dual Sliding Doors	07M00-20-L.2	Light Grey	11 lbs	15 mins
Sprinter High Roof	07M00-20-H	Light Grey	11 lbs	15 mins
Sprinter High Roof Dual Sliding Doors	07M00-20-H.2	Light Grey	11 lbs	15 mins



ProMaster City (122" WB)	07R01-20	Light Grey	7 lbs	15 mins
ProMaster 118" WB	07R02-20	Light Grey	8 lbs	15 mins
ProMaster Low Roof	07R00-20-L	Light Grey	8 lbs	15 mins
ProMaster Low Roof Dual Sliding Doors	07R00-20-L.2	Light Grey	8 lbs	15 mins
ProMaster High Roof	07R00-20-H	Light Grey	8 lbs	15 mins
ProMaster High Roof Dual Sliding Doors	07R00-20-H.2	Light Grey	8 lbs	15 mins

MAKE & MODEL      PART #      COLOUR      WEIGHT      INSTALL



NV 200 (115" WB)	07N01-20-H	Light Grey	8 lbs	15 mins
NV Cargo (140" WB) Low Roof	07N02-20-L	Light Grey	8 lbs	15 mins
NV Cargo (140" WB) High Roof	07N02-20-H	Light Grey	10 lbs	15 mins



Chevy City Express (115") WB	07G01-20	Light Grey	9 lbs	15 mins
GMC Savana RWB/EWB	07G00-20	Light Grey	9 lbs	15 mins



### Additional Product Extensions / Info

Crew Van Door Liner Kits only include panels for the rear doors.

- .3 Hinged Side Doors
- .5 Dual Doors and Dual Wheels
- .7 Rear Liftgate
- .8 Super Single and Dual Sliding Doors
- .N No Side Doors



# ECONOMAT RUBBER MAT

## SPECIFICATIONS

MAKE & MODEL	PART #	WEIGHT	INSTALL
			
Transit Connect (105") SWB	09F01-31	18 lbs	10 mins
Transit Connect (121") LWB	09F02-31	22 lbs	10 mins
Transit 130" WB	09F03-31	36 lbs	10 mins
Transit 148" WB	09F04-31	42 lbs	10 mins
Transit 148" Ext. WB	09F05-31	54 lbs	10 mins

			
Mercedes-Benz			
Metris (126") RWB	09M01-31	44 lbs	15 mins
Metris (135") EWB	09M05-31	46 lbs	15 mins
Sprinter 144" WB	09M02-31	48 lbs	15 mins
Sprinter 170" WB	09M03-31	60 lbs	15 mins
Sprinter 170" Ext. WB	09M04-31	65 lbs	15 mins

			
RAM			
Promaster City (122" WB)	09R01-31	22 lbs	10 mins
Promaster 118" WB	09R02-31	36 lbs	15 mins
Promaster 136" WB	09R03-31	44 lbs	15 mins
Promaster 159" WB	09R04-31	53 lbs	20 mins
Promaster 159" Ext. WB	09R05-31	55 lbs	20 mins

## ECONOMAT RUBBER MAT DOES NOT INCLUDE SILL PLATES

MAKE & MODEL	PART #	WEIGHT	INSTALL	RETAIL
				
NV 200 (115" WB)	09N01-31	20 lbs	10 mins	
NV Cargo (140" WB) LR/HR	09N02-31	38 lbs	20 mins	

				
GMC				
Chevy City Express (115") WB	09G01-31	20 lbs	10 mins	
GMC Savana RWB	09G02-31	37 lbs	10 mins	
GMC Savana EWB	09G03-31	44 lbs	10 mins	

### Additional Product Extensions

- .1 Dual Wheels
- .2 Dual Side Sliding Doors
- .4 with OEM doorway step trim
- .5 Dual Doors and Dual Wheels
- .6 Super Single Rear Wheels
- .8 Super Single and Dual Sliding Doors
- .9 Dual Wheels and OEM Trim
- .N No Side Doors
- .A Rear AC
- .H Handbrake console cutout



# ECONOFLOOR RIGID FLOOR

## SPECIFICATIONS

MAKE & MODEL	PART #	WEIGHT	INSTALL
			
Transit Connect (105") SWB	01F01-33	37 lbs	10 mins
Transit Connect (121") LWB	01F02-33	45 lbs	15 mins
Transit 130" WB	01F03-33	100 lbs	20 mins
Transit 148" WB	01F04-33	100 lbs	20 mins
Transit 148" Ext. WB	01F05-33	128 lbs	30 mins

			
Mercedes-Benz			
Mercedes Metris (126") RWB	01M01-33	97 lbs	20 mins
Mercedes Metris (135") EWB	01M05-33	104 lbs	20 mins
Sprinter 144" WB	01M02-33	108 lbs	20 mins
Sprinter 170" WB	01M03-33	135 lbs	20 mins
Sprinter 170" Ext. WB	01M04-33	150 lbs	20 mins

			
RAM			
Promaster City (122" WB)	01R01-33	74 lbs	20 mins
Promaster 118" WB	01R02-33	85 lbs	20 mins
Promaster 136" WB	01R03-33	95 lbs	20 mins
Promaster 159" WB	01R04-33	121 lbs	20 mins
Promaster 159" Ext. WB	01R05-33	133 lbs	20 mins

## ECONOFLOOR RIGID FLOOR DOES NOT INCLUDE SILL PLATES

MAKE & MODEL	PART #	WEIGHT	INSTALL
			
NV 200 (115" WB)	01N01-33	47 lbs	10 mins
NV Cargo (140" WB) LR/HR	01N02-33	100 lbs	20 mins

			
GMC			
Chevy City Express (115") WB	01G01-33	47 lbs	10 mins
GMC Savana RWB	01G02-33	95 lbs	20 mins
GMC Savana EWB	01G03-33	102 lbs	20 mins

### Additional Product Extensions

- .1 Dual Wheels
- .2 Dual Side Sliding Doors
- .4 with OEM doorway step trim
- .5 Dual Doors and Dual Wheels
- .6 Super Single Rear Wheels
- .8 Super Single and Dual Sliding Doors
- .9 Dual Wheels and OEM Trim
- .N No Side Doors
- .A Rear AC
- .H Handbrake console cutout





LIKE A  
**LEGEND**