

# LITTLE

## TECHNICAL FEATURES

SET · 20 in · 2 Drawers

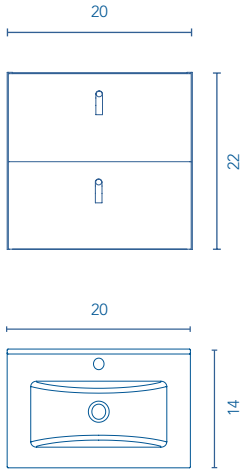

SET · 24 in · 2 Drawers

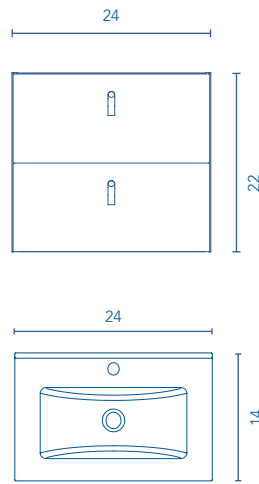

## TECHNICAL INFORMATION

|                       |  |
|-----------------------|--|
| STRUCTURE:            | Foil wrapped 5/8 in. board   |
| FRONT:                | Foil wrapped MDF 5/8 in. board   |
| HANDLE:               | Leather handles.   |
| DRAWER:               | Drawers made in smoky leather poly laminate coated board with hidden full extraction runners with soft close system. Lower drawer useful space (widthxhighxdepth): 16x4x10 in. (unit 20 in.), 20x4x10 in. (unit 24 in.). |
| WALL HANGING BRACKET: | Hidden hanging brackets with direct assembling system, great resistance and depth regulation.  |
| PIPE DEPTH:           | Space behind drawer is 3 inches.   |

## SIPHON PLACEMENT

2 Drawers

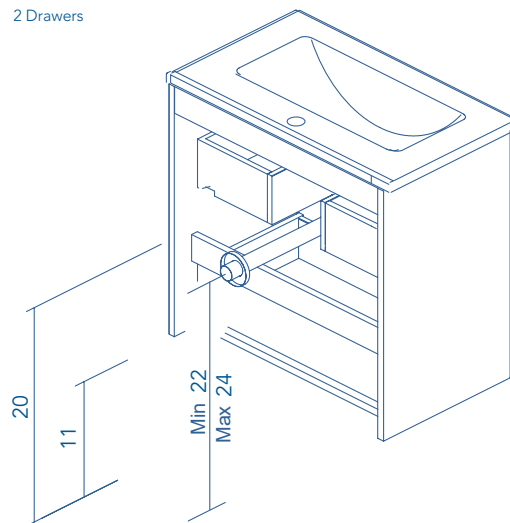

## FINISHES



WHITE OAK

GREY ELM

MATT WHITE