

TORQUE SPECIFICATIONS (Grade 8 & Class 10.9)

5/16" NUTS	20 FT. LBS.	M6	9 FT. LBS.
3/8" NUTS	35 FT. LBS.	M8	23 FT. LBS.
7/16" NUTS	60 FT. LBS.	M10	45 FT. LBS.
1/2" NUTS	90 FT. LBS.	M12	75 FT. LBS.
9/16" NUTS	160 FT. LBS.	M14	120 FT. LBS.
5/8" NUTS	175 FT. LBS.	M16	165 FT. LBS.

EXISTING HARDWARE TORQUE SPECIFICATIONS

CALIPER TO KNUCKLE ALLEN HEAD	38 ft. lbs.
CALIPER TO KNUCKLE HEX HEAD	221 ft. lbs.
LOWER CONTROL ARM NUTS	107 ft. lbs.
TIE ROD NUTS	40 ft. lbs.
FRONT SHOCK NUTS (upper & lower)	20 ft. lbs.
REAR SHOCK NUTS (upper)	13 ft. lbs.
REAR SHOCK NUTS (lower)	74 ft. lbs.
LOWER BALL JOINT NUTS	74 ft. lbs.
UPPER BALL JOINT NUTS	37 ft. lbs.
STABILIZER BAR NUTS	13 ft. lbs.
SPLASH SHEILD BOLTS	19 ft. lbs.



4/3/13

**'99-'06 CHEVROLET/GMC
'07 CHEVROLET/GMC CLASSIC
IFS 4WD
6" SUSPENSION SYSTEM**

P/N. 10-41099

INSTALLATION INSTRUCTIONS

NOTE: Each Lift Kit and options to Lift Kits are packaged separately. Therefore, installation procedures are covered in separate instructions. Familiarize yourself with each specific set of instructions before beginning.

Parts List

<u>Item</u>	<u>Description</u>	<u>Qty.</u>	<u>Illus.</u>
Box 1 of 6			
20-51099-1	Front Crossmember	1	
20-51099-2	Rear Crossmember	1	14
Box 2 of 6			
20-51099-5D	Front Spindle (Drvr.)	1	
20-51099-6P	Front Spindle (Pass.)	1	
Box 3 of 6			
20-51099-24	Lateral Compression Struts	2	14
20-51099-22	Bracket, Strut Mount	2	14
20-67889	Hardware Pack Containing:		
15-11148	Bushing, Red	8	14
20-830918	Sleeve, 3/4" x 2-3/4" Lg.	4	14
20-832738	Sleeve, 3/4" x 1.03" Lg.	2	14
20-67902	Hardware Pack Containing:		
13-20069-Z	Hex Bolt, 1/2"-13 x 4"	4	14
13-21014-Z	Hex Bolt, 1/2"-13 x 3"	2	14
13-30034-Z	Flat Washer, 1/2" SAE	12	14
13-10038-Z	Nyloc Nut, 1/2"-13	6	14
Box 4 of 6			
20-51099-3	Bracket, Torsion Bar Drop (Drvr.)	1	
20-51099-4	Bracket, Torsion Bar Drop (Pass.)	1	
20-51099-7	Bracket, Differential Support	1	9
20-51099-8	Bracket, Differential Drop	1	10
20-830658	Block, Rear- 4"	2	16
20-67837	Hardware Pack Containing:		
20-51099-20	Drive Axle, Spacer	2	11
13-22639-Z	Hex Bolt, 10mm x 1.5 x 60mm Lg.	12	11
13-30642-Z	Flat Washer, 10mm	12	11
13-90490	Loctite, Compound	1	

17) After the rear lift is complete, final ride height adjustment should be performed. Manually bounce the front and rear of the vehicle to pre-settle the bar and springs. Evenly adjust the torsion bar bolts until the front of the vehicle is approximately 1/2" above the final desired ride height. Bars will settle slightly after vehicle is driven.

NOTE: Each bar may require slightly different adjustment to level vehicle side to side.

SOME FINAL NOTES

- After installation is complete, double check that all nuts and bolts are tight. Refer to the torque specifications chart on the last page.
- If new tires are installed that are more than 10% taller than original tires, the speedometer must be recalibrated for the Rear Wheel Anti-Lock Brake System to function properly. Contact an Authorized GM dealer for details on recalibration.
- With vehicle on the floor, cycle the steering lock to lock and inspect steering, suspension and driveline systems for proper operation, tightness and adequate clearance. Recheck brake/hose fitting for leaks. Be sure all hoses are long enough.
- Have headlights readjusted to proper setting.
- Realign front end to factory specifications. Be sure vehicle is at desired ride height prior to realignment.

5) Carefully remove C-Clamps and set the helper spring aside.

NOTE: Add-a-Leaf will be placed in the spring assembly progressively according to length. For example, if existing leaves are 32" long and 25" long and the Add-a-Leaf is 28" long, place the Add-a-Leaf between the existing leaves.

6) Apply a small amount of grease to the end of the Add-a-Leaf. Place leaf in the spring assembly as described in the note above and reassemble the leaf spring using C-Clamps.

7) Insert new center bolt and torque center bolt nut to 20 ft. lbs.

CAUTION: Do not try to compress the spring with the center bolt.

8) Install new Leaf Clips (13-90737-1) and Leaf Caps (13-90737-2) as shown in (Illustration 15).

9) Insert new riser Block (20-830658) on axle pad. Make sure the pin in the block indexes into the hole of the axle housing spring pad. The short end of the block goes toward the front of the vehicle. Carefully raise rear axle until block makes contact with leaf spring. Make sure center bolt is aligned with hole in block (Illustration 16).

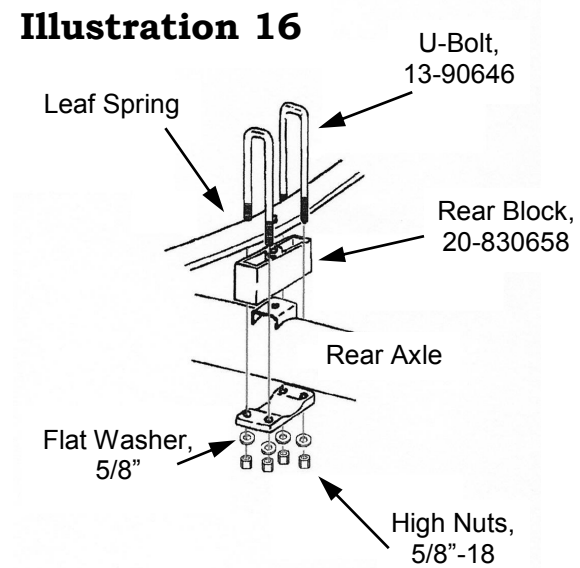

10) Re-mount axle to spring using the new U-bolts, Washers and High Nuts with existing spring plates. Torque U-bolts nuts to 85-100 ft.-lbs.

11) Repeat steps 3 through 10 on passenger side.

12) Install new longer Shock Absorbers (BE5-6134-T5). Using the existing hardware attach the shock to lower axle mount. Attach shock to upper frame mount and torque the nuts to specifications listed on page 21.

13) Remove existing rear bumpstop from the bottom of the frame rail.

14) Install rear bumpstop assembly to the frame rail at the original bumpstop location, using the hardware provided. Torque 3/8" nuts to 30 ft.-lbs.

15) Repeat steps 9 thru 11 on opposite side.

16) Install rear tire/wheel assemblies and lower the vehicle. Torque lug nuts to 140 ft.-lbs.

20-67850	Hardware Pack Containing: (Torsion Bar Drop)	
13-21118-Z	Hex Bolt, 7/16"-14 x 1-1/4" Lg. Gr. 8	8
13-30304-Z	Flat Washer, 7/16" Hrdn.	16
13-10384-Z	Top Lock Nut, 7/16"-14 Gr. C	8
15-11174	Bushing, Red	4
20-832257	Sleeve, 3/4" x 1.52" Lg.	2
20-67863	Hardware Pack Containing: (Diff. Support & Drop)	
13-21144-Z	Hex Bolt, 9/16"-12 x 3-1/2" Gr. 8	1
13-22665-Z	Hex Bolt, 9/16"-12 x 1-3/4" Gr. 8	2 10
13-22704-Z	Hex Bolt, 7/16"-14 x 3" Gr. 8	1 9
13-22639-Z	Hex Bolt, 10mm x 1.5 x 60mm Gr. 10.9	4 9
13-30395-Z	Flat Washer, 9/16" Hrdn	6 10
13-30304-Z	Flat Washer, 7/16" Hrdn.	2 9
13-30642-Z	Flat Washer, 10mm Hrdn.	4 9
13-10397-Z	Top Lock Nut, 9/16"-12 Gr. C	3 10
13-10384-Z	Top Lock Nut, 7/16"-14 Gr. C	1 9
15-11148	Bushing, Red	2 9
20-832725	Sleeve, 3/4" x .095 x 2.25" Lg.	1 9
20-69917	Hardware Pack Containing: (Sway Bar Extension)	
20-833739	Sway Bar Extension (9-1/2")	2 12
13-22743-Z	Button Head Bolt, 1/2"-13 x 3"	2 12
13-30694-Z	Washer, Bushing Retainer 1-1/4"	6 12
13-10878-Z	Nyloc Nut, 1/2"-20	2 12
15-11616	Bushing, Swaybar Link Inner	2 12
15-11629	Bushing, Swaybar Link Outer	2 12
15-11746	Bushing, Swaybar Flex Joint	4 12
20-67915	Hardware Pack Containing:(F/R Crossmember)	
13-21950-Z	Hex Bolt, 5/8"-11 x 5-1/2" Gr. 8	2
13-22028-Z	Hex Bolt, 5/8"-11 x 4-1/2" Gr. 8	2
13-22223-Z	Hex Bolt, 9/16"-12 x 3-3/4" Gr. 8	1
13-30369-Z	Flat Washer, 5/8" Hrdn.	8
13-30395-Z	Flat Washer, 9/16" Hrdn.	2
13-10345-Z	Top Lock Nut, 5/8"-11 Gr. C	4
13-10397-Z	Top Lock Nut, 9/16"-12 Gr. C	1
11-15144	Spacer, 1" x .31"	2

20-68097	Hardware Pack Containing: (Rear Bumpstop Ext.)		
20-51099-23	Rear, Bumpstop Extension	2	
13-22756-Z	Hex Bolt, 10mm x 1.5 x 30mm Lg.	2	
13-30577-Z	Lock Washer, 10mm	2	
13-30642-Z	Flat Washer, 10mm	2	
20-67928	Hardware Pack Containing: (Bumpstop)		
15-11018	Bumpstop, Low Profile	2	
13-30012-Z	Flat Washer, 3/8" SAE	2	
13-10022-Z	Nyloc Nut, 3/8"-16	2	
20-68188	Hardware Pack Containing: (U-Bolts)		
13-30330	Flat Washer, 9/16" Hrdn.	8	16
13-10423	High Nut, 9/16"-18	8	16
20-68305	Hardware Pack Containing: (Universal)		
13-20447-Z	Unslot Hex, #10 x 1/2"	4	
15-10966	Clamp, 3/8" x 3/8" x .203"	4	
15-11395	Wire Tie, 6"	4	
15-11447	Wire Tie, 8"	2	
15-11460	Wire Tie, 11"	2	
13-90646	U-Bolt, 9/16"-18 x 12-1/2"	4	16
20-830554	Frame Cap	1	7

Box 5 of 6

13-70013-1	Rear, Add-A-Leaf	2	15
20-68240	Hardware Pack Containing: (Pins)		
13-90750	Center Pin, 3/8"-24 x 6" w/Nut	2	
20-68344	Hardware Pack Containing: (Clamps)		
13-90737-1	Leaf Clip, 2-1/2"	4	15
13-90737-2	Leaf Cap, 2-1/2"	4	15

Box 6 of 6

BE5-6133-T5	Shock Absorber (Front)	2	
BE5-6134-T5	Shock Absorber (Rear)	2	

REAR INSTALLATION

1) Raise the vehicle. If working without a shop hoist, support vehicle with suitable safety stands. To do this put vehicle in gear, block front wheels, both in front and behind tires, then disengage emergency brake. Place floor jack underneath rear axle and raise vehicle. Place safety jack stands under frame to support vehicle and lower vehicle onto safety stands. Remove rear tire/wheel assemblies.

2) Use a floor jack to raise the rear axle just enough to relieve tension from the shock absorbers and remove them.

3) Remove rear U-bolts attaching rear axle to driver side leaf spring. Carefully lower rear axle.

CAUTION: Do not allow axle to hang by any hoses or cables.

4) Hold the spring assembly securely together with C-Clamps (**Illustration 15**). Remove any spring leaf alignment clamps. Remove the spring center bolt. If necessary, use a hammer and punch to drive it out.

Illustration 15

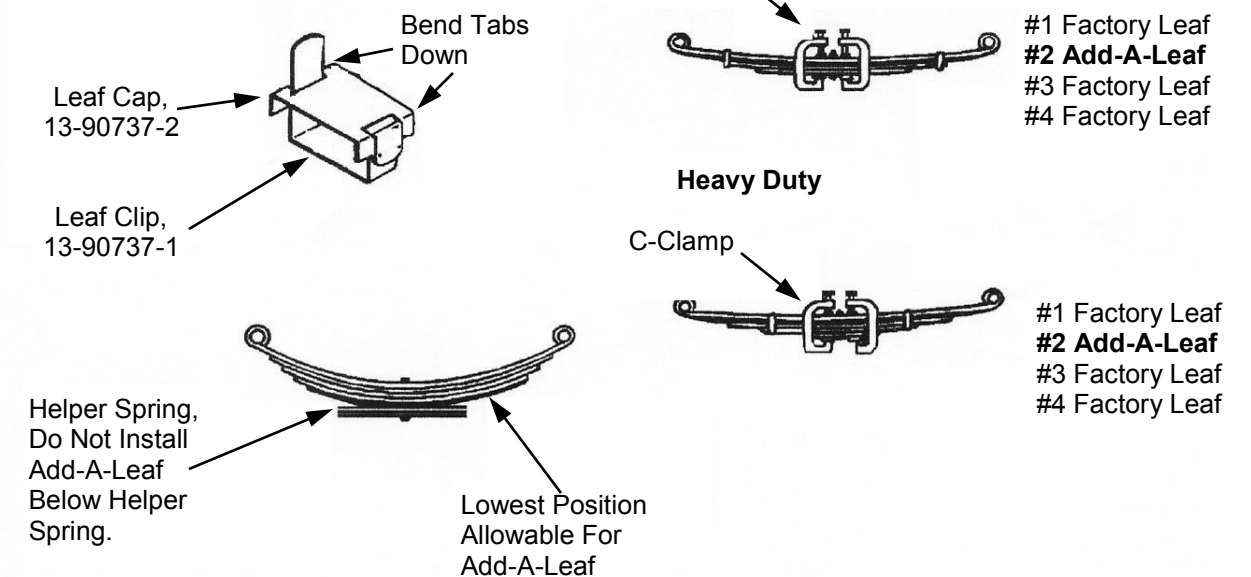

INTRODUCTION

26) Attach Strut Mount Bracket (20-51099-22) to opposite end of the compression strut. Rotate the compression strut assembly upward until bracket contacts the bottom of the trans crossmember. Use the bracket as a guide to mark and then center punch the mounting hole locations. Drill 1/2" hole at each of the marked locations. Install using the 1/2" hardware provided. Torque the nuts to 65 ft. lbs.

27) If vehicle is equipped with a transmission skid plate, notch the skid plate for clearance of the strut mount bracket. Reinstall the skid plate using existing hardware.

28) Position Torsion Bar Drop Brackets (20-51099-3 Drvr.; 20-51099-4 Pass.) against the frame rail centered directly below the old torsion bar crossmember bracket. Using the bracket as a guide, mark and center punch the mounting hole locations. Drill 7/16" diameter hole at each of the marked locations.

CAUTION: Check the inside of the frame rail before drilling. Move any components (gas lines, brake lines, etc.) that might get damaged.

29) Load torsion bars into their respective lower control arms. Slide torsion bars forward.

30) Install Bushing (15-11148) and Sleeves (20-832725) into torsion bar drop brackets. Attach torsion bar drop brackets to the torsion bar crossmember using the existing hardware previously removed.

31) Install the torsion bar crossmember assembly into the previously drilled holes. Fasten using 7/16" hardware provided and torque nuts to 60 ft. lbs.

32) Slide the torsion bar rearward through the torsion bar crossmember while holding the adjustment arm in the proper position. Verify that reference marks on the adjustment arm and torsion bar matches.

33) Install the Torsion Bar Unloading Tool (J 36202). Be very careful while increasing tension on the torsion bar.

34) Reinstall the retainer plate and adjusting bolt. Thread the adjusting bolt until exposed length matches the measured length before removal. This way, they can be installed in the stock position.

35) Repeat steps 24 thru 34 on opposite side.

36) Install front tire/wheel assemblies and lower vehicle to the ground.

37) When the vehicle is at ride height, torque the lower control arm to front and rear crossmember pivot nuts to 121 ft. lbs.

38) Torque Sway Bar Extension 1/2"-13 x 3" Button Head bolts to 66 ft. lbs.

- Installation by a professional mechanic is recommended. Use of the appropriate power tools, a Chevrolet/GMC service manual and a shop hoist can greatly reduce installation time.
- Prior to installation, carefully inspect the vehicle's steering and drive train systems, paying close attention to the tie rod ends, Pitman and Idler Arms, Ball Joints and wheel bearing preload. Also check steering-to-frame and suspension-to-frame attaching points for stress cracks. The overall vehicle must be in excellent working condition; repair or replace worn parts,
- Read instructions carefully and study the illustrations before attempting installation. Race Car Dynamics is not responsible for damage, failure or injury resulting from improper installation or parts substitution of this kit.
- Check the parts and hardware against the parts list to assure that your kit is complete. Report any shortages to Race Car Dynamics at (1-619-588-4723). The parts and hardware supplied are of high-grade material and must not be replaced by inferior parts or failure may result.
- Separate parts according to the areas they will be used. Placing the hardware with brackets before you begin will save installation time.
- All components in this kit come with a protective coating. Do not plate (i.e. chrome, cadmium, zinc etc.) or otherwise alter the finish in any way. This could weaken the structural strength of the components.
- Secure and properly block vehicle prior to beginning installation.
- Always wear safety glasses when using power tools.
- Foot-pound torque readings are listed on the Torque Specifications chart at the end of the instructions unless specifically stated in an instruction. **DO NOT USE AN IMPACT WRENCH TO TIGHTEN ANY OF THE BOLTS.**
- Thoroughly clean frame contact points where any new bolt-on brackets contact frame. Frame coatings or grime can eventually melt away and reduce torque values.

PLEASE NOTE

WARNING: DO NOT USE WHEEL SPACERS.

- No special drive shaft is required. Stock drive shafts are retained.
- Some models may require an exhaust modification to clear front drive shaft.
- Front-end alignment is necessary.
- Clears 33" x 12.50" tires on 16 x 8 " wheels, or 35" x 12.50" with minor bumper trimming.
- Requires 16" wheels with a maximum of 4-1/2" of back spacing, or 4-5/8" back spacing on 17" wheels.
- System will not work on vehicles equipped with electronic and/or air ride suspension systems.
- Speedometer recalibration is necessary if bigger tires (10% more than stock diameter) are installed.

Special tools are required for safe removal and installation of the tie-rods and, torsion bars. These tools can be purchased from your GM dealer.

Ball Joint Separator Tool # J 43631
Torsion bar Unloading Tool # J 36202
Steering Linkage Puller Tool # J 24319

21) Install new longer front shock absorbers (BE5-6133-T5).

NOTE: You need at least 1/4" clearance between shock body and stock bumpstop frame bracket. If clearance is needed, grind leading edge of stock bumpstop bracket (**Illustration 13**).

22) Repeat steps 10 thru 21 on opposite side.

23) Cycle front suspension through full travel cycle and check for adequate clearance between shocks, bumpstops and brake line hoses.

NOTE: If clearance is needed for front shocks, grind leading edge (arrow) of stock bumpstop bracket.

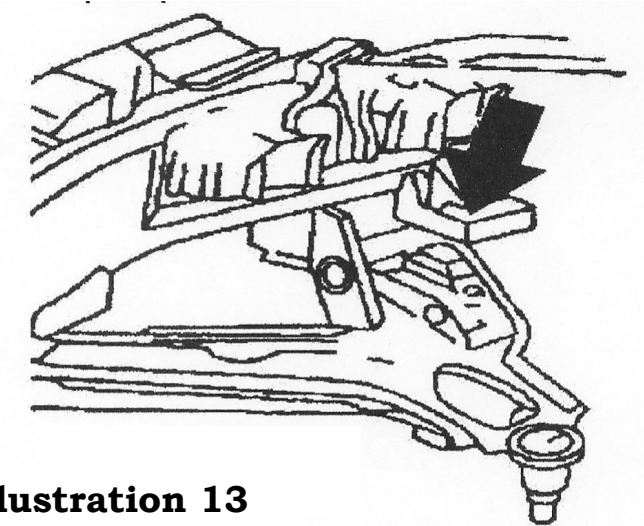

Illustration 13

24) Install Bushings (15-11148) and Sleeves (20-830918) into both ends of the Lateral Compression Struts (20-51099-24). Attach Lateral Compression Strut to Strut Mount bracket located on rear crossmember using hardware provided (**Illustration 14**). Do not tighten at this time.

25) Remove transmission skid plate, if equipped.

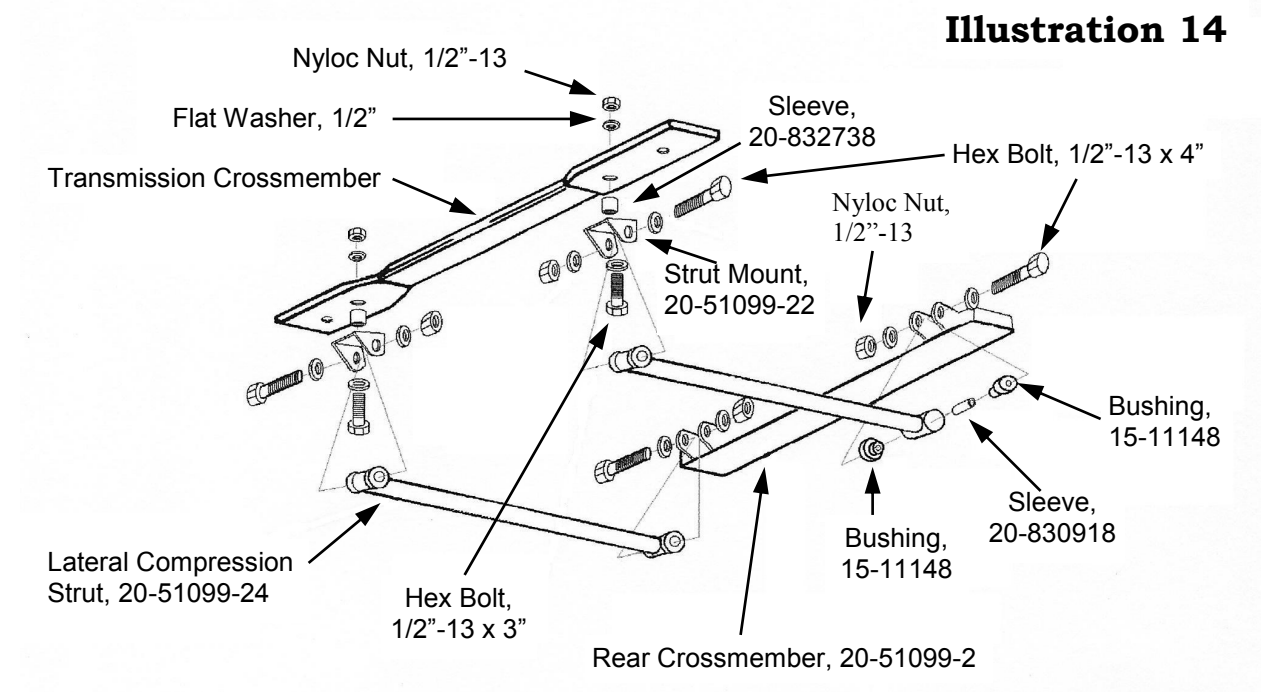

Illustration 14

18) Install brake rotor. Reattach the front caliper with existing hardware. Torque caliper mounting bracket hex bolts (to spindle) to 129 ft. lbs. If equipped with Allen Head caliper pins torque to 38 ft. lbs. If applicable, connect the ABS sensor cable at the frame near upper control arm.

19) Torque axle hub to 165 ft. lbs.

20) Assemble existing sway bar to lower control arm using Sway Bar Extension (20-833739) using hardware provided (**Illustration 12**). Do not tighten at this time.

NOTE: Torque Extension hardware to 66 ft. lbs. once vehicle is on the ground and ride height has been achieved.

When installing the RCD Flex Joint sway bar links, hole in lower control arm MUST be drilled out to a minimum of 5/8" and a maximum of 3/4", which is recommended, and edges ground smooth. Failure to do so may result in shearing off of attaching bolt.

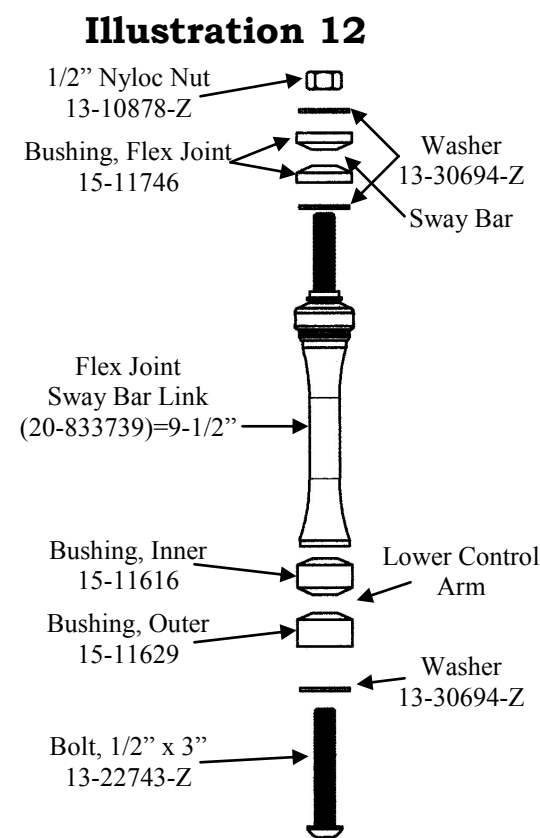

IMPORTANT NOTICE TO INSTALLER

When installing the RCD Flex Joint sway bar links, this hole **MUST** be drilled out to a minimum of 5/8" and a maximum of 3/4", which is recommended, and edges ground smooth. Failure to do so may result in shearing off of attaching bolt.

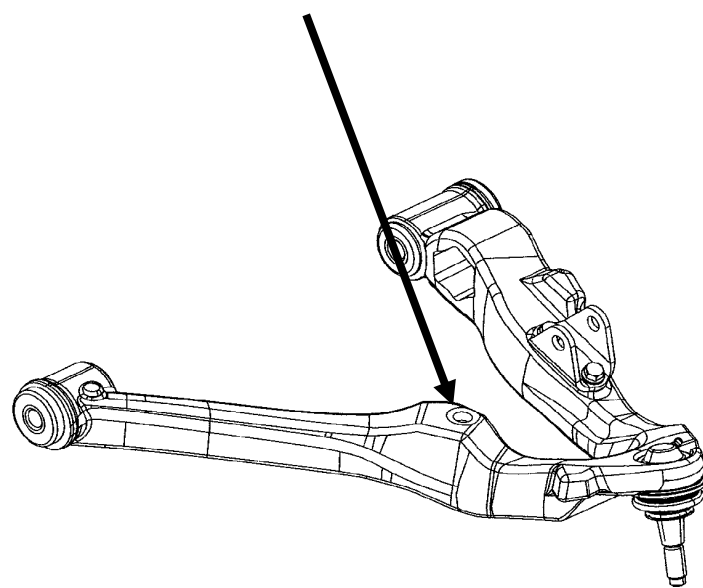

FRONT DISASSEMBLY

1) GETTING STARTED: Measure ride height with the vehicle supporting its own weight. Ride height is the measured distance from the center of the spindle to the top of the fender well (**Illustration 1**).

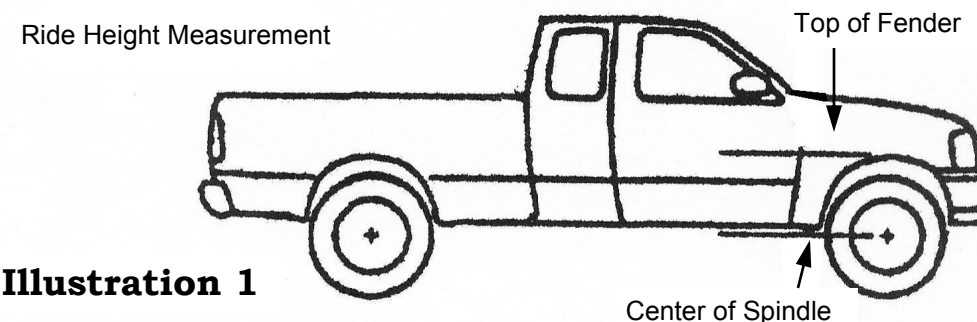
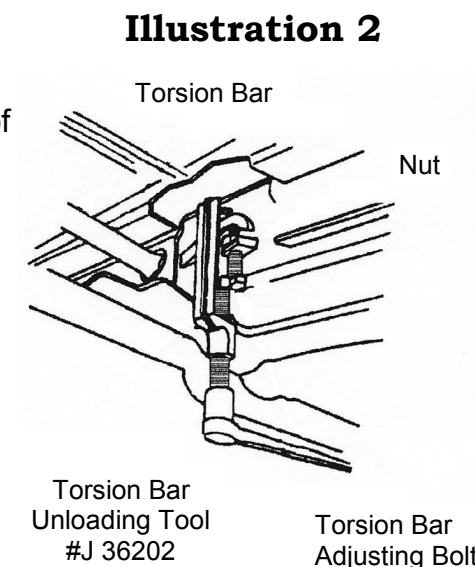

Illustration 1

2) Raise the vehicle. If working without a shop hoist, put vehicle in gear. Set emergency brake and block rear wheels, in front and behind tires. Loosen front wheel lug nuts. Place floor jack under the lower control arm's front cross member and raise the vehicle. Place safety jack stands under frame rails, behind front wheel wells, and lower the frame onto the stands. Remove front wheels.

WARNING: Be extremely careful when loading or unloading the torsion bars. There is tremendous amount of stored energy in the bars. Keep your hands and body clear of the adjuster arm assembly and puller tool in case anything breaks.

3) Measure Torsion Bar Adjusting Screw depth for replacement of Torsion Adjuster Arm. Remove the torsion bar adjusting screw. Apply a small amount of grease to the puller threads and the puller shaft-to-adjuster arm contact point. Position the puller and load adjuster arm until the adjuster nut can be removed from the crossmember (**Illustration 2**). With the bar unloaded, slide it further forward into the lower control arm. If the bar seems lodged, use a hammer and punch through the hole in the back of the crossmember. When the bar shifts forward, the adjuster arm will fall.



4) Remove torsion bar crossmember by removing the two bolts that connect crossmember to the frame. With the crossmember out of the way, the torsion bars can be dislodged from the lower control arms and removed. Mark or separate the bars, since they must be reinstalled on the same side they were removed from.

Illustration 3

- 5) Remove the front shock absorbers.
- 6) Detach existing front bumpstops from upper mounting cup.
- 7) Remove anti-sway bar extensions connecting bar body to lower control arms (**Illustration 3**).

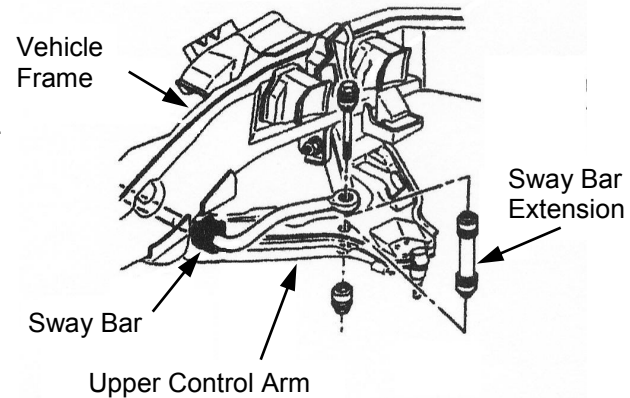

- 8) Mark the differential flange and drive axle flange for installation reference.
- 9) Remove the nut and washer from the hub (**Illustration 4**). Remove six existing bolts fastening drive axle to differential. Pull drive axle out of the hub through the lower control arm.

NOTE: Be careful not to damage drive axle boots.

- 10) Locate the two caliper mounting bracket bolts attaching brake caliper to backside of front spindle. Remove bolts then remove caliper and bracket as an assembly. Use a length of wire to secure caliper assembly out of the way and to prevent damage to brake lines.

CAUTION: Do not allow the brake caliper to hang by the brake hose.

Illustration 4

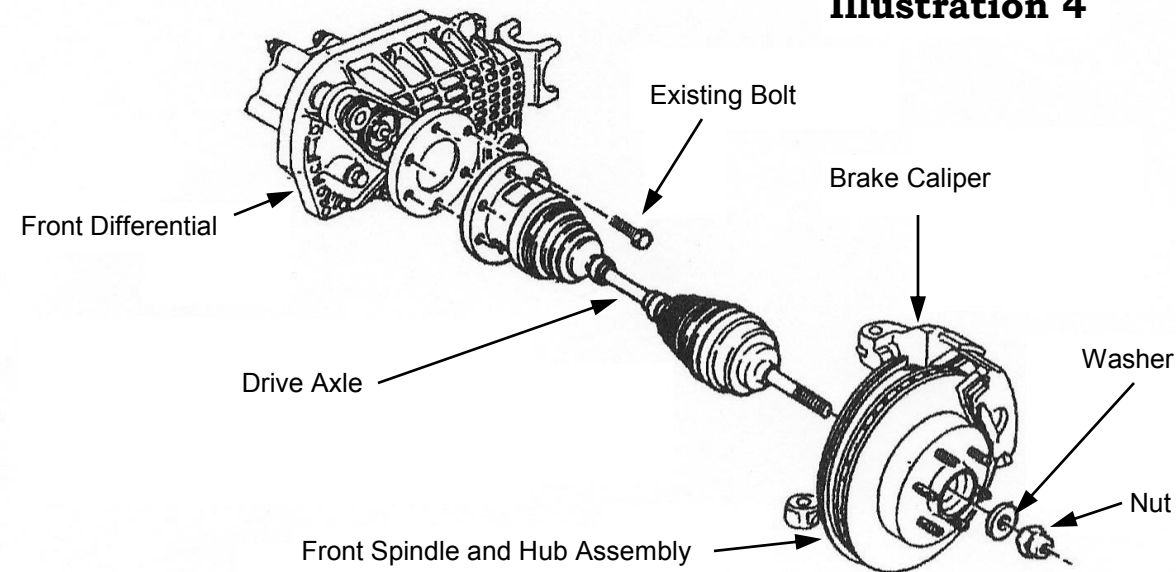

- 11) Torque existing upper control arm to crossmember nuts to 121 ft. lbs. starting with the front then the rear.

- 12) Torque front differential mounting hardware to 75 ft. lbs.

- 13) Remove the splash shield, hub and bearing assembly from existing front spindles. Reinstall the splash shield, hub and bearing assembly to new Front Spindles (20-51099-5D Drvr. and 20-51099-6P Pass.).

NOTE: Make sure that hub and bearing assemblies are reinstalled on the same side they were removed from. Apply Loctite compound to existing hardware. Torque bolts to 133 ft. lbs.

- 14) Connect driver side front spindle assembly to the upper and lower control arm ball joints. Torque upper ball nut to 37 ft lbs. Torque lower ball joint nut to 74 ft. lbs.

- 15) Loosen the tie rod end jam nut and thread the tie rod inward two complete turns. Retighten the jam nut and attach the tire rod to the front spindle. Torque nut to 46 ft. lbs.

- 16) Reinstall the drive axle into front spindle, using hardware previously removed.

NOTE: Do not lubricate the drive axle splines and front spindle with grease.

- 17) Place Drive Axle Spacer (20-51099-20), against the differential flange (**Illustration 11**). Align the reference marks on the axle flange and differential flange, making sure all mounting holes are aligned with each other. Attach using Loctite compound and hardware provided, torque bolts to 58 ft. lbs.

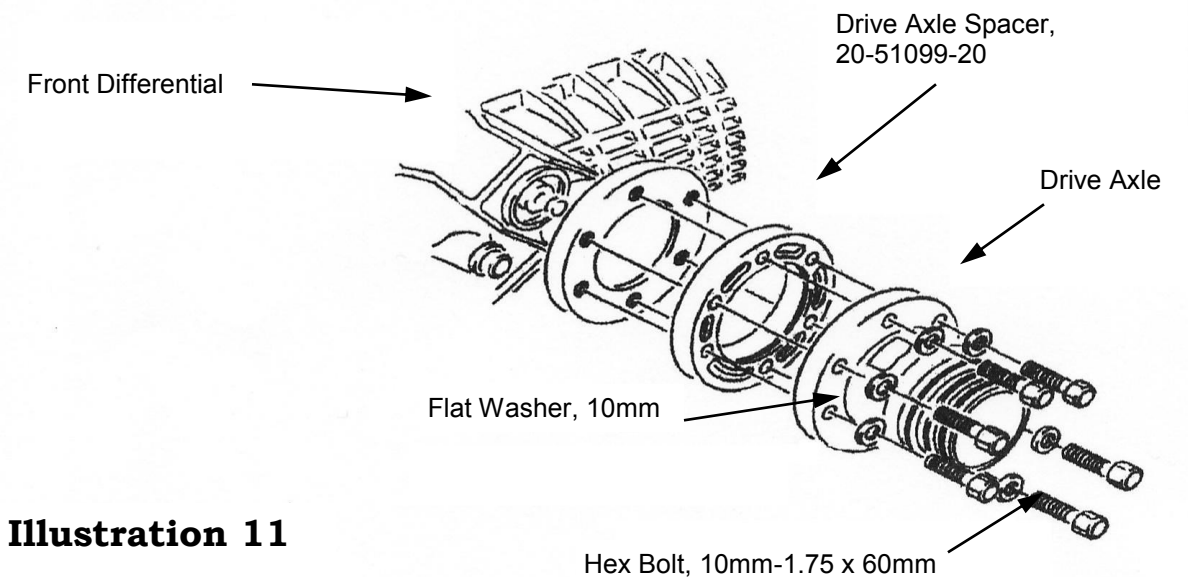

Illustration 11

2) Loosely attach the passenger side Differential Drop Bracket (20-51099-8), to the differential axle. Use hardware provided (**Illustration 10**).

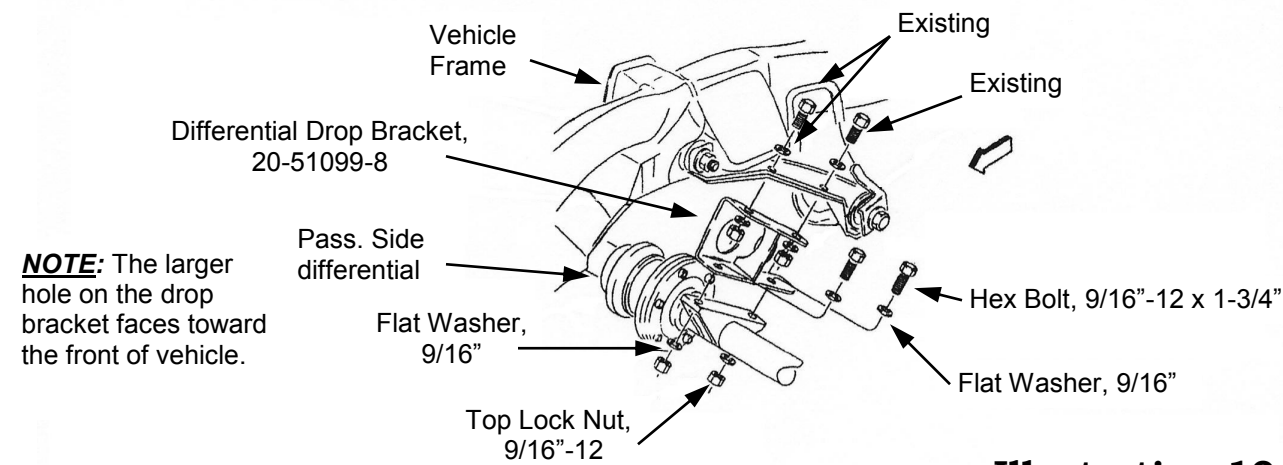

Illustration 10

3) Install Front Crossmember (20-51099-1) into existing front lower control arm mounting pockets using existing hardware previously removed. Make sure the bolt heads are facing toward the front of the vehicle. Do not fasten at this time.

4) Install Rear Crossmember (20-51099-2) into existing rear lower control arm mounting pockets, use existing hardware previously removed. Make sure the bolts heads are facing toward the front of the vehicle. Do not fasten at this time.

5) Attach low profile Bumpstops (15-11018) to the rear crossmember bumpstop pad, using the hardware provided.

6) Support the front differential assembly with a floor jack. Slowly raise the differential assembly into position.

7) Place the front driver side Differential Support Bracket between the tabs located on front crossmember. Position the rear driver side differential mount to rear crossmember differential mounting area. Install passenger side Differential Drop to frame bracket, using existing hardware. Attach Differential Support Bracket to front crossmember and rear differential mount to rear crossmember using existing hardware previously removed. Do not fasten at this time.

8) Connect the differential vent hose and electrical connector.

9) Align marks made on the front drive shaft U-joint and differential yoke and reconnect the front drive shaft to the differential.

10) Install lower control arms into the front and rear crossmembers using the 5/8" hardware provided. Do not fasten at this time.

Illustration 5

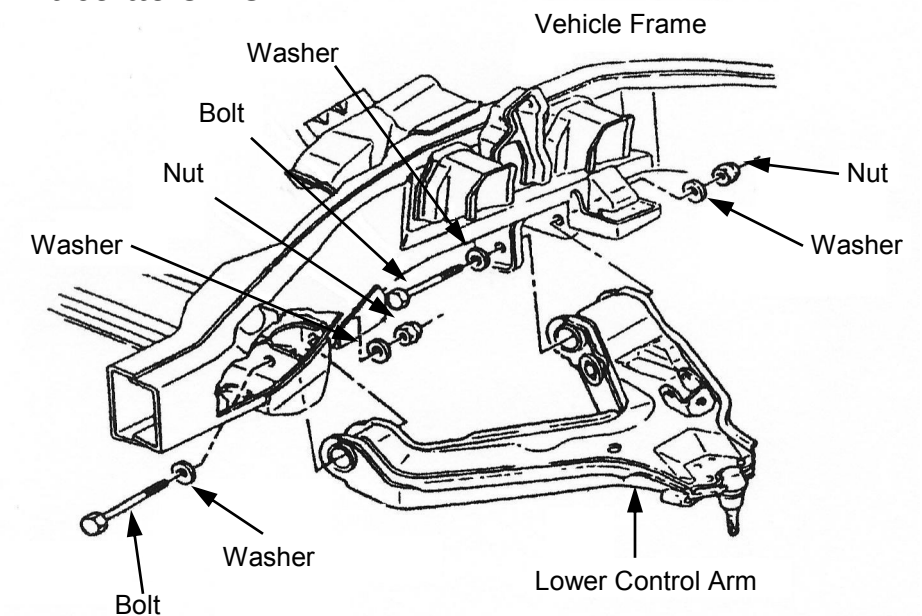

11) Remove the brake rotor. Locate tie rod end and remove the nut. Attach the Universal Steering Link Puller (J 24319) and separate the tie rod end from the front spindle.

12) Separate the ABS sensor cable at the frame near upper control arm, if applicable.

13) Locate front lower ball joint, remove nut from ball joint. Using Ball Joint Separator Tool (J 43631) apply pressure on tool until ball joint breaks loose from lower part of the front spindle.

14) Locate the front upper ball joint. Remove nut from ball joint. Using Ball Joint Separator Tool (J 43631) apply pressure on tool until ball joint breaks loose from upper part of the front spindle.

15) Remove front spindle with the hub and bearing assembly attached, set aside. Remove the lower control arm pivot bolts and remove lower control arm (**Illustration 5**).

16) Repeat steps 7 thru 15 on opposite side.

17) Remove the differential skid plate, if vehicle is so equipped.

18) Locate the front drive shaft U-joint to differential yoke. Place an index mark for installation reference on both the drive shaft U-joint and differential yoke. Remove the hardware from the yoke and slide the shaft rearward to disengage. Tape the bearing cap assemblies and secure the shaft out of the way.

19) Disconnect the electrical connector and vent hose from differential assembly.

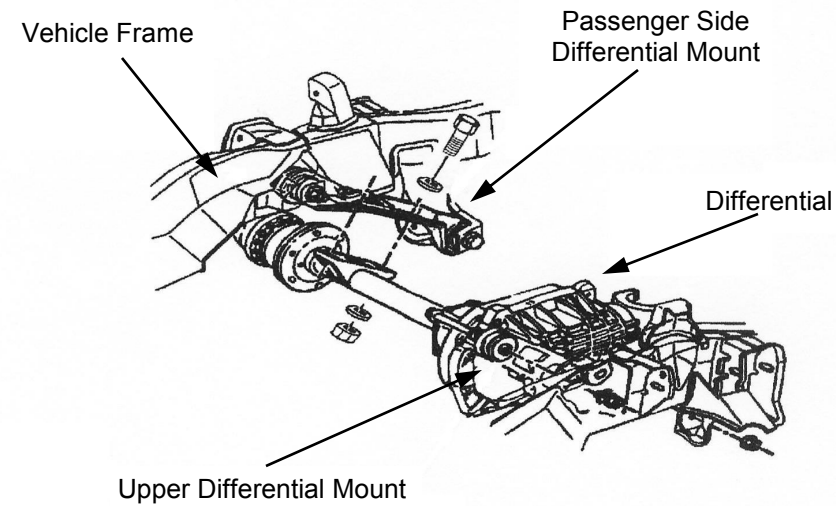

Illustration 6

20) Check differential fluid level. Ensure that fluid level is 1/2" below the fill plug.

21) Support from differential assembly with a floorjack. Remove the upper mounting hardware and passenger side axle hardware (**Illustration 6**). Slowly remove the differential assembly from vehicle, and lower it to the floor.

22) Using a suitable cutting tool, cut off the rear lower differential mount bracket (driver's side), plus an additional one-inch of the frame supporting the bracket (**Illustration 7**). Weld in the provided Frame Cap (20-830554). File all sharp edges and paint exposed metal.

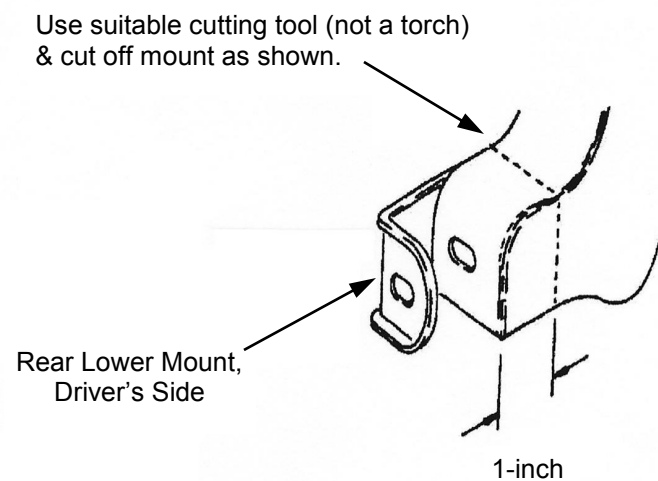
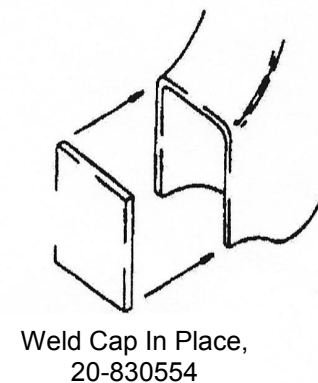

Illustration 7



23) Locate the upper mount on front differential housing. Cut off upper mount flush to main case (**Illustration 8**). If the driver side wrap around differential mount bracket was properly modified grinding to clearance the case will not be necessary. If necessary, remove material from the left side of the differential to provide clearance for the lower control arm frame mount

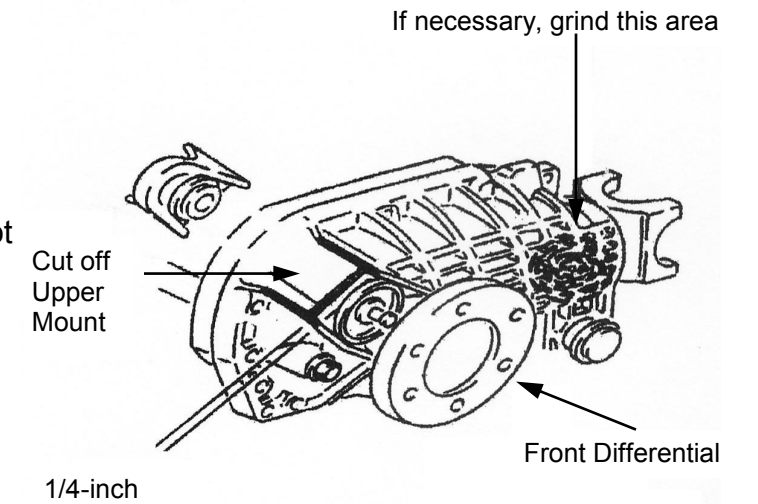

Illustration 8

FRONT INSTALLATION

1) Install Bushings (15-11148) and Sleeve (20-832725), into Differential Support Bracket (20-51099-7). Attach Differential Support Bracket assembly to the front differential (**Illustration 9**). Use Loctite compound and hardware provided. Torque to specification chart on last page of instructions.

NOTE: When attaching the Differential Support Bracket, gear oil may leak from the case. Place this assembly in a large oil pan before removing hardware to catch the excess oil. Add one excess pint of factory recommended lubricant to *full* differential while out of vehicle by tipping on side. (*Axle Lubricant GM P/N 1052271 or SAE 80W-90 GL-5 Gear Lubricant*)

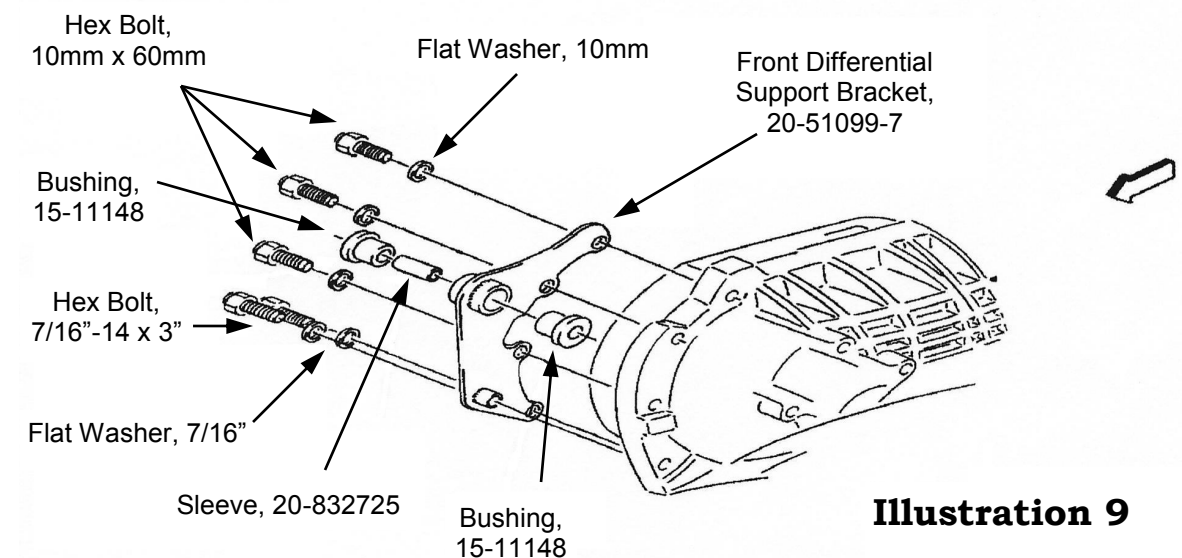

Illustration 9