



5/10/04

***'01-'04 Chevy/GMC HD2500
2WD/4WD Dual Shock Kit***

P/N 10-31800

INSTALLATION INSTRUCTIONS

NOTE: Each lift kit, and options to lift kits, are packaged separately. Therefore installation procedures are covered in separate instructions. Familiarize yourself with each specific set of instructions before beginning.

PART LIST

ITEM	DESCRIPTION	QTY.	ILLUS.
Box 1 of 2			
20-31800-1	Shock Hoop Assembly	2	2
20-31899-5	Lower Shock Mount (Driver's Side)	1	1
20-31899-6	Lower Shock Mount (Passenger's Side)	1	1
20-70138	Hardware Pack Containing: (1/2" Hardware)		
13-22873-Z	Bolt, 1/2" x 5" Gr. 8	4	2
13-22249-Z	Bolt, 1/2" x 3-1/2" Gr. 8	4	2
13-21430-Z	Bolt, 1/2" x 2-3/4" Gr. 8	8	
13-30382-Z	Flat Washer, 1/2" Hrdn.	32	2
13-10514-Z	TopLoc Nut, 1/2"	16	2
20-70151	Hardware Pack Containing: (3/8" Hardware)		
13-23497-Z	Bolt, 3/8" x 3" Gr. 8	4	1
13-21482-Z	Bolt, 3/8" x 2-1/2" Gr. 8	4	1
13-30408-Z	Flat Washer, 3/8" Hrdn.	16	
13-10553-Z	TopLoc Nut, 3/8"	8	
Box 2 of 2			
50-BE5-6237-T5	Shock, Front Dual	4	2

INTRODUCTION

- ⊙ Installation requires a professional mechanic. Read instructions carefully and study illustrations before attempting installation. **RCD Suspensions** is not responsible for damage, failure or injury resulting from improper installation or parts substitution of this kit.
- ⊙ Check parts and hardware against parts list to assure that your kit is complete. Report shortages to **RCD Suspensions** at (1-619-588-4723). The parts and hardware supplied are of high-grade material and must not be replaced by inferior parts or failure may result.
- ⊙ Separate parts according to the areas they will be used. Placing the hardware with brackets before you begin will save installation time.

- ⊙ This kit is supplied as a bolt-on assembly. Do not weld anything to components and do not weld components to the vehicle.
- ⊙ All components in this kit come with a protective coating. Do not plate (i.e. chrome, cadmium, zinc etc.) or otherwise alter the finish in any way. This could weaken the structural strength of the components
- ⊙ Secure and properly block vehicle prior to beginning installation.
- ⊙ Always wear safety glasses when using power tools.
- ⊙ Foot-pound torque readings are listed on the Torque Specifications chart at the end of the instructions unless specifically stated in an instruction. **DO NOT USE AN IMPACT WRENCH TO TIGHTEN ANY OF THE BOLTS.**

INSTALLATION

- 1) Raise the vehicle. If working without a shop hoist, put vehicle in gear, set emergency brake and block rear wheels, in front and behind tires. Loosen lug nuts. Lift vehicle with floor jack and place safety jack stands under frame rails, behind front wheel wells, and lower onto stands. Remove the front tire/wheel assemblies.
- 2) Disconnect Brake line anchor from top of upper control arm.
- 3) Locate Dual Shock Lower Mount (20-31899-5 Drvr., 20-31899-6 Pass.). Position Lower Mount onto top of upper control arm. The mount's side plates will help position mount properly. The shortest side tab should be located right next to where the stock brake line mount was located on the upper control arm. If the tab is not there you have the wrong mount.

- 4) Align holes in mount with two existing holes on top of control arm. **(Illustration 1)** Mark the other two holes to be drilled on upper control arm. Remove mount and drill two marked holes and two existing holes to 3/8". Holes are to be drilled all the way through the upper control arm.

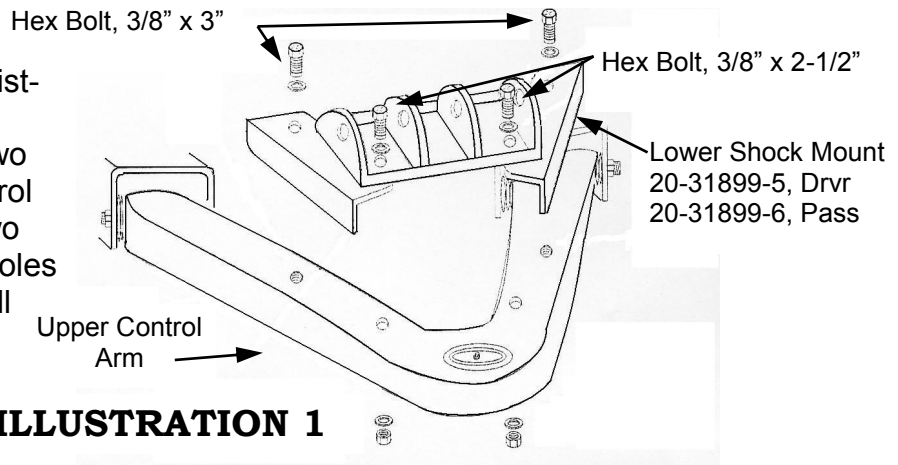

ILLUSTRATION 1

- 5) Install Lower shock mount to upper control arm using 3/8" x 3" Bolts with Flat Washers and Nuts provided towards center of vehicle and 3/8" x 2-1/2" Bolts with hardware towards outside of vehicle. Do not torque at this time. Attach brake line bracket to upper control arm in stock location using new hardware. Drill bracket hole to 3/8" if needed.

6) **Repeat steps 2-5 on opposite side of vehicle.**

7) Position hoop (20-31800-1) inside wheel well. The outer sleeves facing each other on the main part of the hoop slide over the outer part of the factory upper control arm pivots as looking into wheel well.

8) Slide hoop down till two support tubes on hoop are position flat against factory frame rail on each side of the stock upper shock mount. The top edge of the sleeve should be 1/2" below top flat surface of frame rail.

9) Using the hoop mark the center of each of the sleeves on the frame and the upper control arm pivot mounts and remove hoop.

NOTE: All sleeves should fit flat against surfaces. On some vehicles in order to get the hoop to fit correctly there is a bullet tipped bolt sticking out of the frame right beside the factory upper control arm pivot. Grind bolt down to allow clearance for hoop to fit if needed.

10) Drill each of the 4 locations marked with a 1/2" drill. Make sure to drill all the way through frame rails.

11) Position hoop back in place and secure using 1/2" hardware as shown in **Illustration 2**. Do not torque at this time.

12) **Repeat steps 7-11 on opposite side of vehicle.**

13) Install shocks with boots facing down using 1/2" x 2-3/4" bolts and hardware provided. Bolt heads should be facing outwards as looking into wheel well.

14) Torque all 3/8" hardware to 35 ft.lbs. Torque all 1/2" hardware to 90 ft.lbs.

