



4/10/13

**2007-13 TOYOTA TUNDRA  
2WD & 4WD  
6" SUSPENSION SYSTEM  
P/N: 10-47407**

**INSTALLATION INSTRUCTIONS**

**NOTE:** Each lift kit, and options to lift kits, are packaged separately. Therefore installation procedures are covered in separate instructions. Familiarize yourself with each specific set of instructions before beginning.

# Part List

<u>Item</u>	<u>Description</u>	<u>Qty.</u>	<u>Illus.</u>
<b>Box 1 of 5</b>			
20-57407-1	Front Crossmember	1	9, 11, 19
20-57407-2	Rear Crossmember	1	8,10, 11,19
<b>Box 2 of 5</b>			
20-57407-5D	Spindle, Driver	1	14
20-57407-6P	Spindle, Passenger	1	
<b>Box 3 of 5</b>			
20-57407-13	Compression Strut	2	20
20-51292-11	Compression Strut Mount Bracket	2	20
20-71097	Hardware Pack (Bushings)		
15-11148	Bushing, Red-Large	8	20
20-830918	Sleeve, .75"OD x .095w x 2.75"	4	20
20-71435	Hardware Pack (Compression Strut)		
13-20069-Z	Hex Bolt, 1/2"-13 x 4"	4	20
13-10038-Z	Nut, 1/2"-13 Nylon Insert Lock	6	20
13-30034-Z	Washer, 1/2" SAE Flat	12	20
13-22249-Z	Hex Bolt, 1/2"-13 x 3-1/2"	2	20
<b>Box 4 of 5</b>			
20-57407-3	Bumpstop Drop (Drvr.)	1	18
20-57407-4	Bumpstop Drop (Pass.)	1	
20-57407-7	Skid Plate	1	19
20-830658	Rear Tapered Block, 4"	2	22
13-90087	U-Bolt, 9/16" x 2-5/8" x 11-7/16"	4	22
20-68188	Hardware Pack (U-Bolt)		
13-30330	Washer, 9/16" Flat	8	22
13-10423	Nut, 9/16" Fine High	8	22
20-71370	Hardware Pack (Vent Hose)		
15-11980	Hose, 7/32" x 9"	1	

20-71123	Hardware Pack (Park Brake)		
13-10155-Z	Nut, 5/16"-18 Nylon Insert Lock	2	23
13-21157-Z	Hex Bolt, 5/16"-18 x 3/4"	2	23
13-30187-Z	Washer, 5/16" SAE Flat	4	23
20-57405-16	Park Brake Cable Bracket	2	23
20-71149	Hardware Pack (Front Brakeline)		
20-57405-12	Front Brakeline Drop	2	17
13-30187-Z	Washer, 5/16" SAE Flat	4	17
13-21157-Z	Hex Bolt, 5/16"-18 x 3/4"	2	17
13-10155-Z	Nut, 5/16"-18 Nylon Insert Lock	2	17
20-71318	Hardware Pack (Front Crossmember)		
20-57407-10	Washer, Centering	4	9
13-23783-Z	Hex Bolt, 18mm x 130mm	2	9
13-10969-Z	Nut, 18mm Nylon Insert Lock	2	9
20-71331	Hardware Pack (Rear Crossmember)		
20-57407-11	Washer, Centering Tab	3	10
13-23796-Z	Hex Bolt, 18mm x 150mm	2	10
13-10969-Z	Nut, 18mm Nylon Insert Lock	2	10
13-21534-Z	Hex Bolt, 3/8"-16 x 1"	3	10
13-30151-Z	Washer, 3/8" Lock	3	10
13-30408-Z	Washer, 3/8" Flat	3	10
20-57407-9	Diff Support Bracket	1	10
20-57407-12	Nut Strip, Rear Crossmember	1	10
20-71344	Hardware Pack (Sway Bar Links)		
20-57407-15	Sway Bar Link (Drvr.)	1	16
20-57407-16	Sway Bar Link (Pass.)	1	
13-23809-Z	Hex Bolt, 14mm x 70mm	2	16
13-30160-Z	Washer, 14mm Flat	4	16
13-10852-Z	Nut, 14mm Top Lock	2	16
20-832374	Sleeve, 5/8" x .0359w x 1.47"	4	16
15-11083	Bushing, Hour Glass	4	16
20-71383	Hardware Pack (Differential Mount)		
13-23822-Z	Hex Bolt, 9/16" x 6-1/2"	2	11
13-10397-Z	Nut, 9/16" Top Lock	2	11
13-30395-Z	Washer, 9/16" Flat	4	11

20-71396	Hardware Pack (Bumpstop Brackets)		
13-23744-Z	Hex Bolt, 10mm x 20mm	4	18
13-30642-Z	Washer, 10mm Flat	8	18
13-10865-Z	Nut, 10mm Top Lock	4	18
20-71409	Hardware Pack (Sway Bar Relocation)		
20-57407-8	Sway Bar Relocation Block	2	15
13-23835-Z	Hex Bolt, 12mm x 25mm	4	15
13-30546-Z	Washer, 12mm Flat	4	15
20-71422	Hardware Pack (Rear Brakeline)		
13-21157-Z	Hex Bolt, 5/16" x 3/4"	3	
13-30187-Z	Washer, 5/16" Flat	6	
13-10155-Z	Nut, 5/16" Nylon Insert Lock	3	
20-57407-14	Rear Brakeline Bracket, Long	1	
20-57407-17	Rear Brakeline Bracket, Short	2	
20-71045	Hardware Pack (Skid Plate)		
13-30408-Z	Washer, 3/8" Flat Hardened	4	19
13-30151-Z	Washer, 3/8" Split Lock	4	19
13-22938-Z	Hex Bolt, 3/8"-16 x 1-1/4"	4	19
20-68305	Hardware Pack (Misc.)		
13-20447-Z	Screws for Brakeline Clamps	4	
15-10966	Brakeline Clamps	4	
15-11395	Zip Tie, 6"	4	
15-11447	Zip Tie, 8"	2	
15-11460	Zip Tie, 11"	2	
20-69891	Hardware Pack (Carrier Bearing Spacers)		
13-23367-Z	Hex Bolt, 10mm x 60mm	2	
13-30629-Z	Washer, 10mm Flat	2	
13-30577-Z	Washer, 10mm Lock	2	
20-833479	Spacer, Carrier Bearing	2	

## Box 5 of 5

F4-BE5-E980-T0	Front Shock	2	
F4-BE5-E981-T0	Rear Shock	2	

## **INTRODUCTION**

Installation by a professional mechanic is recommended. Use of the appropriate tools, a Toyota service manual, and a shop hoist can greatly reduce installation time.

Prior to installation, carefully inspect the vehicle's steering and drive train systems, paying close attention to the tie-rod ends, rack & pinion unit, ball joints and wheel bearing preload. Also check steering-to-frame and suspension-to-frame attachment points for stress cracks. The overall vehicle must be in excellent working condition; repair or replace worn parts.

Read instructions carefully and study illustrations before attempting installation. **RCD Suspension** is not responsible for damage, failure or injury resulting from improper installation or parts substitution of this kit.

Check parts and hardware against the parts list to assure that your kit is complete. Report any shortages to RCD Suspension at (1-619-588-4723). The parts and hardware supplied are of high-grade material and must not be replaced by inferior parts or failure may result. Do not begin installation if parts are missing.

Separate parts according to the areas they will be used. Placing the hardware with brackets before you begin will save installation time.

This kit is supplied as a bolt-on assembly. Do not weld anything to the components and do not weld the components to the vehicle.

All components in this kit come with a protective coating. Do not plate (i.e. chrome, cadmium, zinc etc.) or otherwise alter the finish in any way. This could decrease the structural strength of the components.

Secure and properly block vehicle prior to beginning installation.

Always wear safety glasses when using power tools.

Foot-Pound torque readings are listed on the Torque Specifications chart at the end of the instructions unless specifically stated in an instruction. **DO NOT USE AN IMPACT WRENCH TO TIGHTEN ANY OF THE BOLTS.**

## **PLEASE NOTE**

### **WARNING: DO NOT USE WHEEL SPACERS**

Front-end realignment is necessary.

Speedometer recalibration is necessary if larger tires (10% more than stock diameter) are installed.

System is designed to accommodate up to a 35" x 12.50" (or metric equivalent) tire on a wheel size of 18" x 9" with a maximum of 5.5" backspacing.

System is designed to work with factory "VSC" systems. VSC systems may be more sensitive than stock under certain driving conditions.

Zero Point Calibration of the VSC system will need to be done after installation and alignment. Please consult a Toyota Factory Service Manual or visit a Toyota Service Department to perform this procedure.

Special tools are required for safe removal and installation of the ball joints, and tie-rods. These tools can be purchased from your Toyota Dealer.

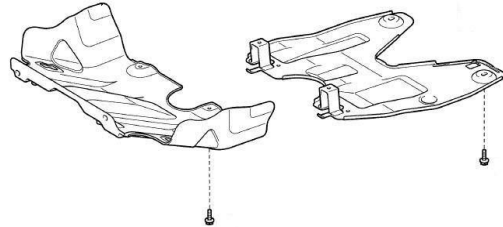
Ball Joint Tool 09628-62011  
Spring Compressor 09727-30021

## **Front Installation Instructions**

1. Raise the vehicle. If working without a shop hoist, support vehicle with suitable safety jack stands. Put vehicle in gear, set emergency brake and block rear wheels, both in front and behind tires. Loosen front wheel lug nuts. Place floor jack under the lower control arm's front crossmember and raise vehicle. Place safety jack stands under frame rails, behind front wheel wells, and lower the frame onto the stands. Once securely on jack, stands remove floor jack. Remove front wheels.

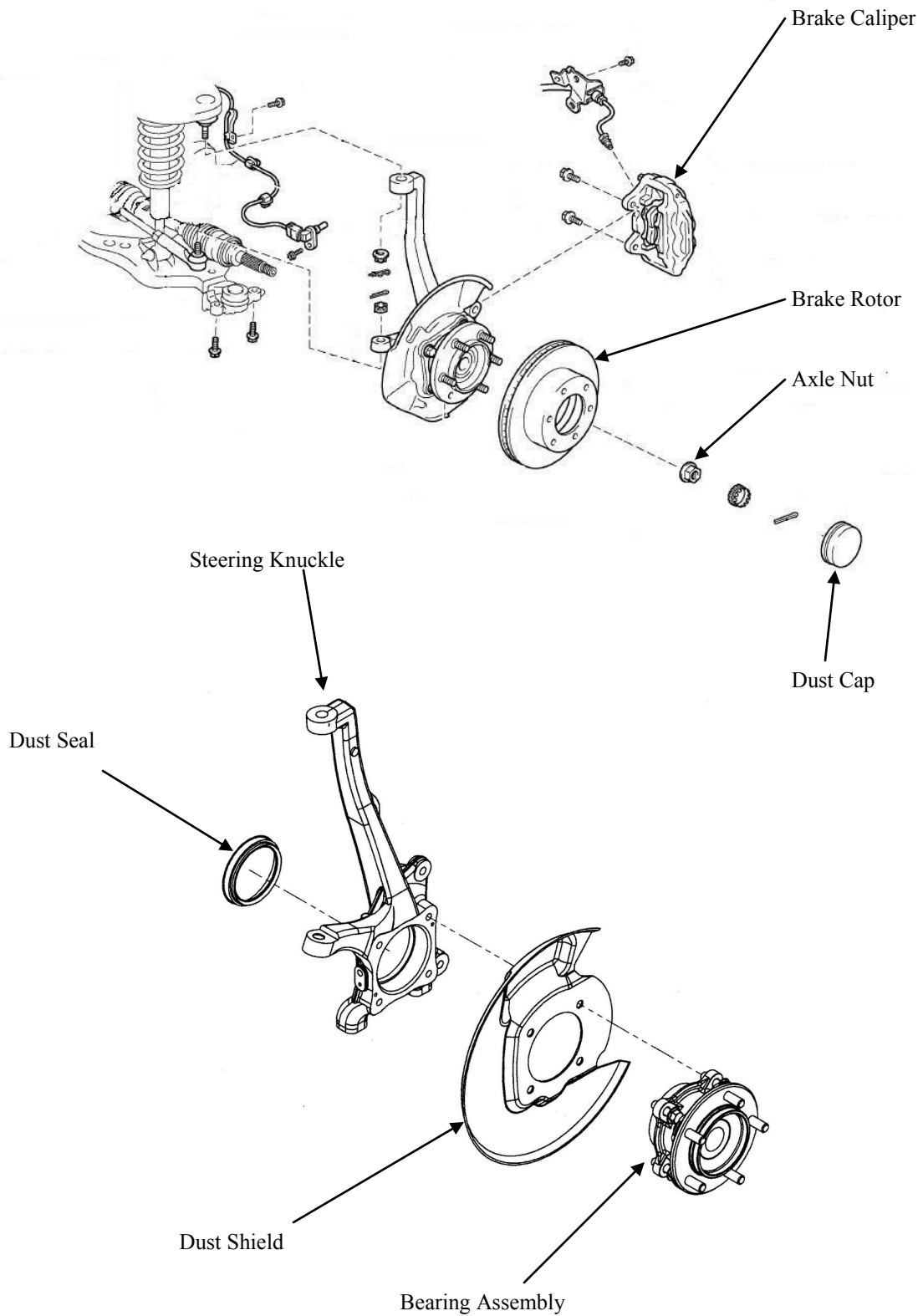
2. Remove the skid plate and skid plate brackets. **(Illustration 1)**

**Illustration 1**



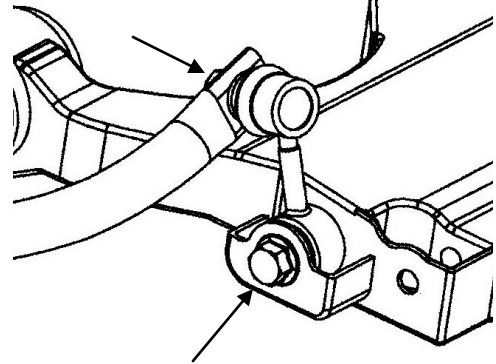
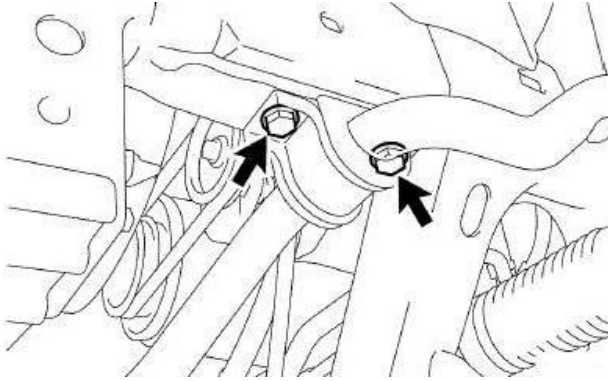
3. Beginning with the drivers side, unclip the ABS sensor line and disconnect at the knuckle. Remove the screw attaching the brakeline to the knuckle. **(Illustration 2)**
4. Remove the bolts holding the Caliper Anchor Bracket to the Steering Knuckle **(Illustration 2)**. Pull the Bracket and Caliper assembly away from the Brake Rotor and hang out of the way with a length of wire, careful not to damage the brake lines.  
**DO NOT let the Caliper hang from the brake line.**
5. Remove the Brake Rotor from the Hub and set aside. **(Illustration 2)**
6. Remove Axle Hub Dust Cap. **(Illustration 2)**
7. Remove the axle to wheel hub nut. **(Illustration 2)**

## Illustration 2





**Illustration 3**



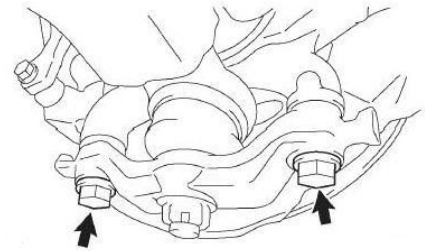
8. Disconnect and remove Sway Bar with Links from vehicle.  
**(Illustration 3)**

9. Remove the nut from the steering Tie Rod. Separate the Tie Rod from the Steering Knuckle. **(Illustration 2)**

10. Remove the nut from the Upper Ball Joint. Separate the Upper Ball Joint from the Steering Knuckle. **(Illustration 2)**

11. Remove the two bolts attaching the Knuckle to Lower Ball Joint Bracket. **(Illustration 4)**

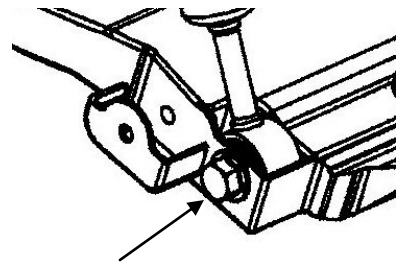
**Illustration 4**



12. Remove Steering Knuckle and set aside.

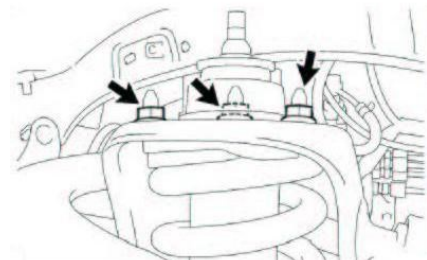
13. Disconnect Front Strut from Lower Control Arm at bottom, and from Frame at top, and remove. **(Illustration 5)**

**Illustration 5**



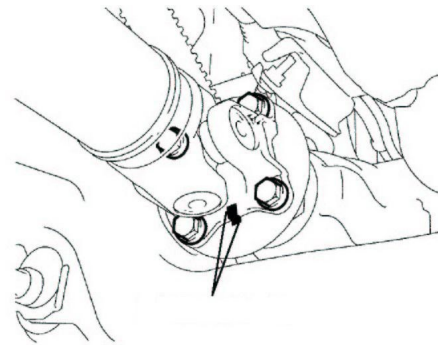
14. Remove the lower control arm pivot bolts and remove lower control arm.

15. Repeat steps 3 thru 14 on opposite side.



16. Locate the front drive shaft U-joint to differential yoke. Place an index mark for installation reference on both the drive shaft U-joint and differential yoke. Remove the hardware from the yoke and slide the shaft rearward to disengage. **(Illustration 6)**

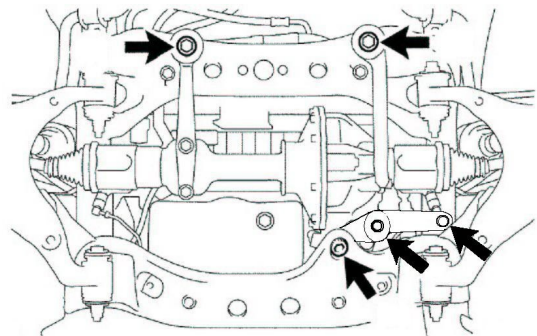
**Illustration 6**



17. Disconnect the electrical connector and vent hose from differential assembly.

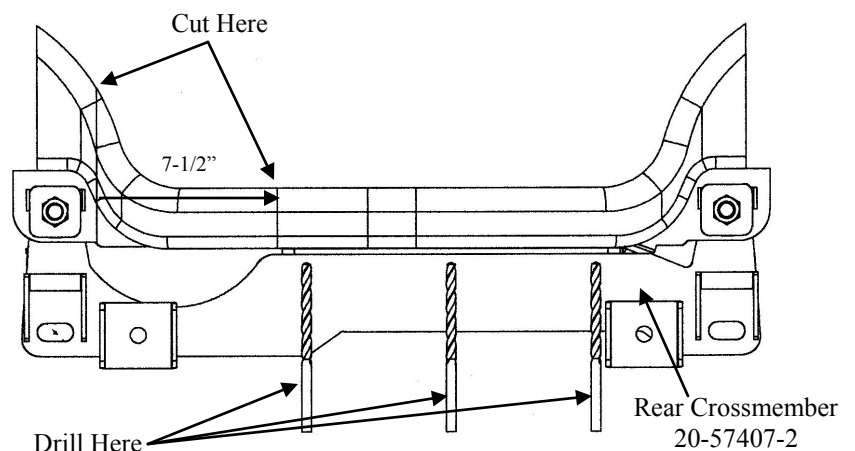
18. Support front differential assembly with a floorjack. Remove the two bolts at bottom of front crossmember and the bracket at the rear. The bracket has three attachment points. Two at the frame and one to differential. Slowly remove the differential assembly from vehicle, and lower it to the floor. **(Illustration 7)**

**Illustration 7**



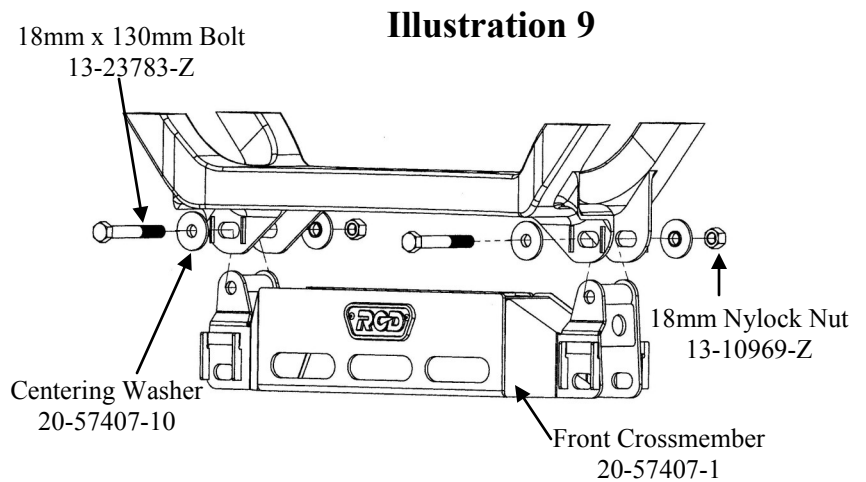
19. Temporarily install Rear Crossmember (RCD 20-57407-2) for reference when marking the frame for the differential cutout. Mark the frame in line with the top plate of the RCD Crossmember. Then measure 7-1/2" over and mark. Also mark the three 13/32" holes to be drilled at the rear edge of the Crossmember. **(Illustration 8)**

**Illustration 8**



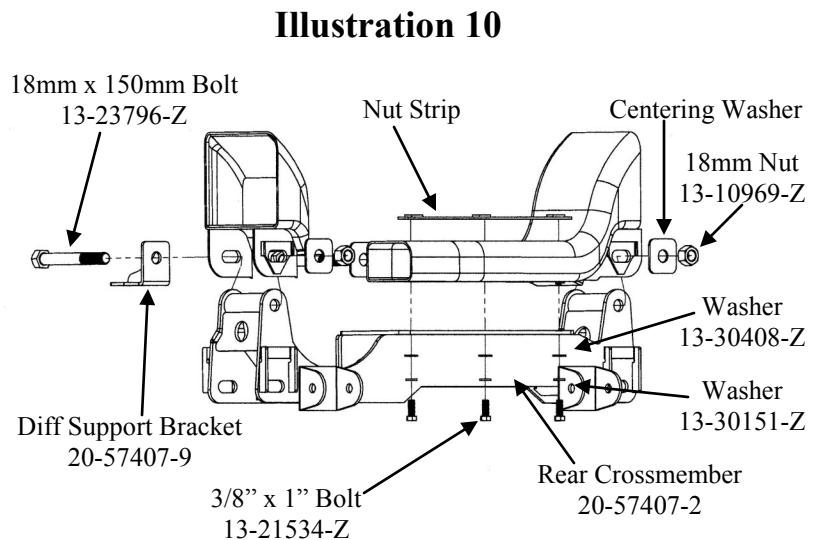
20. Remove the Crossmember to cut the frame.

21. Using a suitable cutting tool, cut out the section of the frame as marked.
22. Drill the three 13/32" holes as previously marked. Paint all bare metal surfaces.
23. Install Front Crossmember (RCD 20-57407-1) into existing front lower control arm mounting pockets using 18mm x 130mm hardware and Centering Washers provided. Do not tighten at this time. **(Illustration 9).**



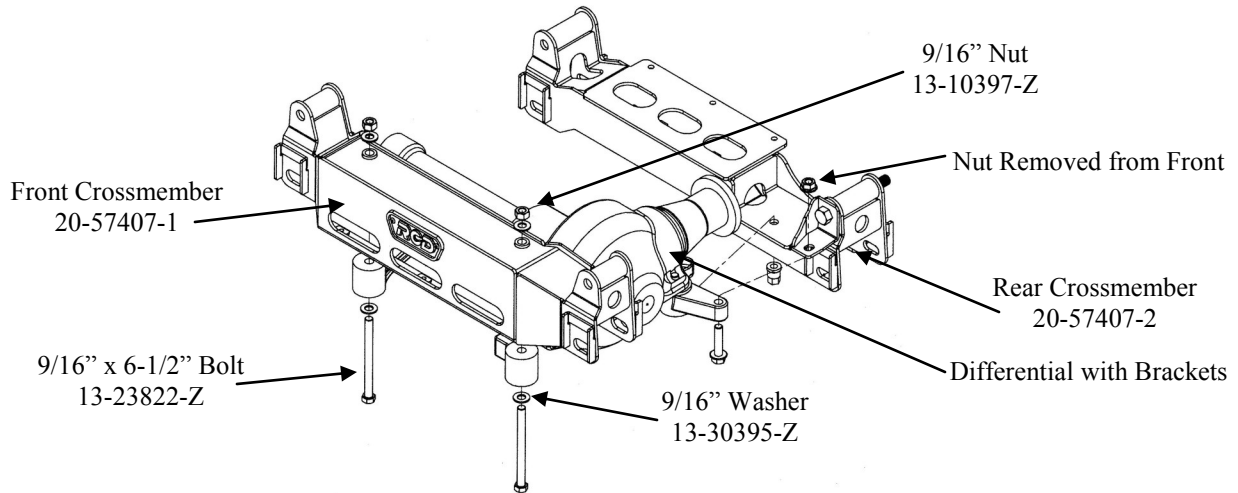
24. Raise Differential assembly into position.

25. Install Rear Crossmember (RCD 20-57407-2) into existing rear lower control arm pockets using 18mm x 150mm hardware and Centering Washer provided. Also install the Diff Support Bracket (RCD 20-57407-9) at this time. Do not tighten at this time. **(Illustration 10)**



26. Insert the two 9/16" bolts attaching the Differential to the Front Crossmember and the original bracket at the rear of the Differential. It will be necessary to use one of the nuts removed from the front attachment bolts to attach the bracket to the Diff Support Bracket installed earlier. Torque the 9/16" bolts to 160 ft. lbs. and the bolts and nut to 95 ft. lbs. **(Illustration 11)**

**Illustration 11**

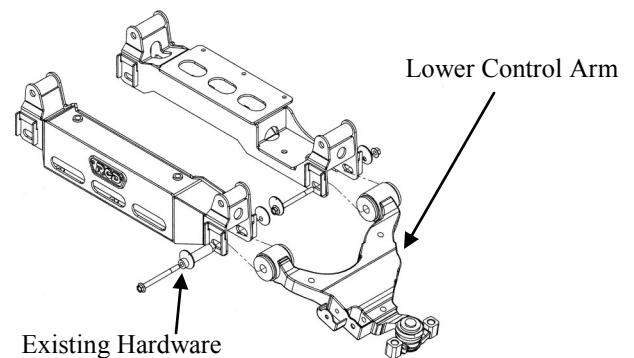


27. Align marks made on the front drive shaft U-joint and differential yoke and reconnect the front drive shaft to the differential.

28. Connect the differential vent hose and electrical connector. Replace the original vent hose with the new one provided.

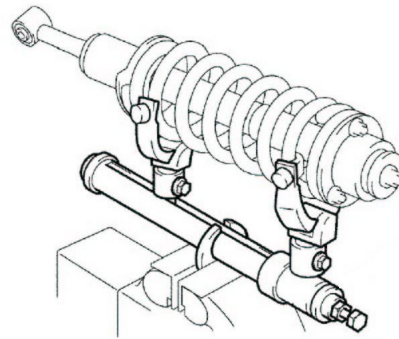
**Illustration 12**

29. Install lower control arms into the front and rear crossmembers using existing hardware previously removed. Do not tighten at this time. **(Illustration 12)**



30. Using an external coil compressor, compress the coil on the stock shock. **The spring is under EXTREME PRESSURE, make sure you use a proper spring compressor and fully understand how to operate it. See page 6 for Toyota's external coil compressor part number.** Once tension is removed off end plate loosen and remove nut on end of shock shaft. Slowly release tension on coil compressor until the coil is completely free. **(Illustration 13)**

**Illustration 13**



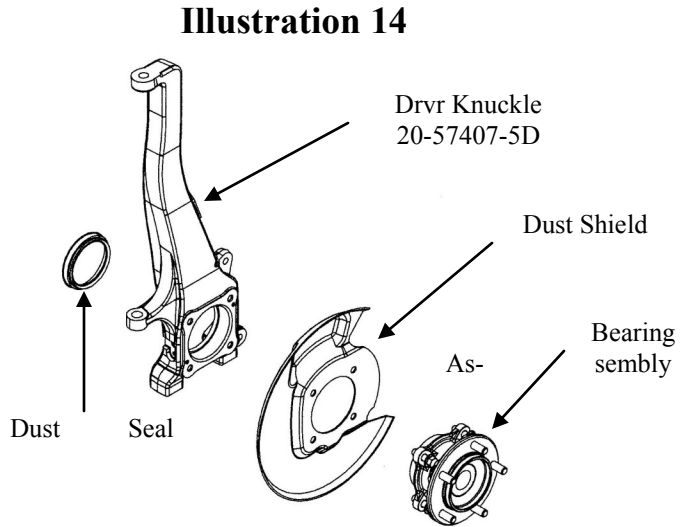
31. Make sure coil seat is securely resting on snap ring of new front Bilstein Shock (50-BE5-E980-T0) provided and place original coil onto the new shock. The end of the coil should sit in a pocket shaped especially for it on the new coil seat. Use the coil compressor and compress the coil enough to put the existing top seat for the coil and new hardware on to shock shaft. Use the 12mm x 1.25 pitch Nyloc Nut provided with the new shock to secure all top hardware. Once tightened, slowly remove coil compressor. **Note that that shock has two snap ring grooves machined in the shock body. The lower groove is for 4" of lift and the upper groove is for 6" of lift.**

32. Position new shock assembly back into original location. Make sure once the top four bolts are in position, with the arrow pointing out, that the bottom eyelet is oriented so that it will fit into the lower control arm and the bolt will fit. Install existing nuts onto top studs on shock mount and torque to 47 ft. lbs. Raise lower control arm into position and install existing lower shock bolt. Torque to 150 ft. lbs.

33. Remove the splash shield, hub and bearing assembly from existing front spindles. Reinstall the splash shield, hub and bearing assembly to new Front Spindles (20-57407-5D Drvr. and 20-57407-6P Pass.) (Illustration 14).

**NOTE: Make sure that hub and bearing assemblies are reinstalled on the same side they were removed from. Apply Loctite compound to existing hardware. Torque bolts to 85 ft. lbs.**

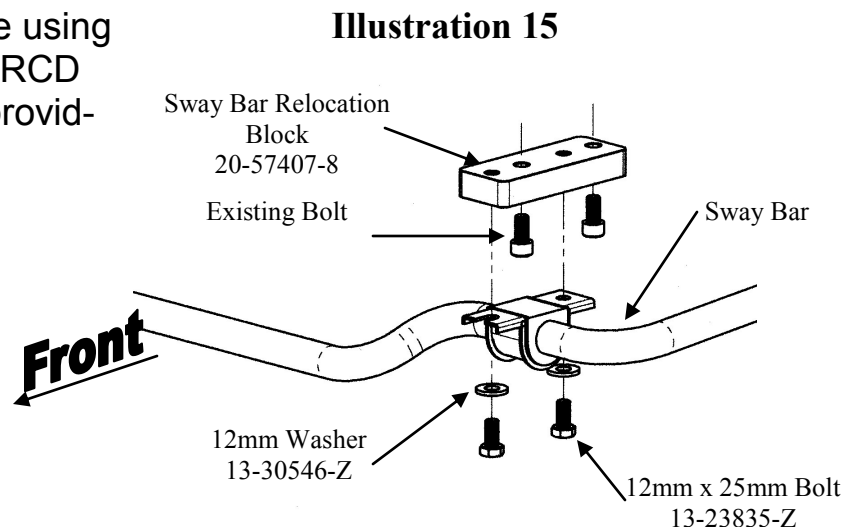
34. Connect driver side front spindle assembly to the upper and lower control arm ball joints. Torque upper ball joint nut to 67 ft lbs. Torque lower ball joint bracket bolts to 230 ft. lbs.



35. Remove both tie rod ends and switch them from side to side. Rotate tie rod so that stud is pointing down and attach the tie rod to the front spindle. Torque nut to 67 ft. lbs.

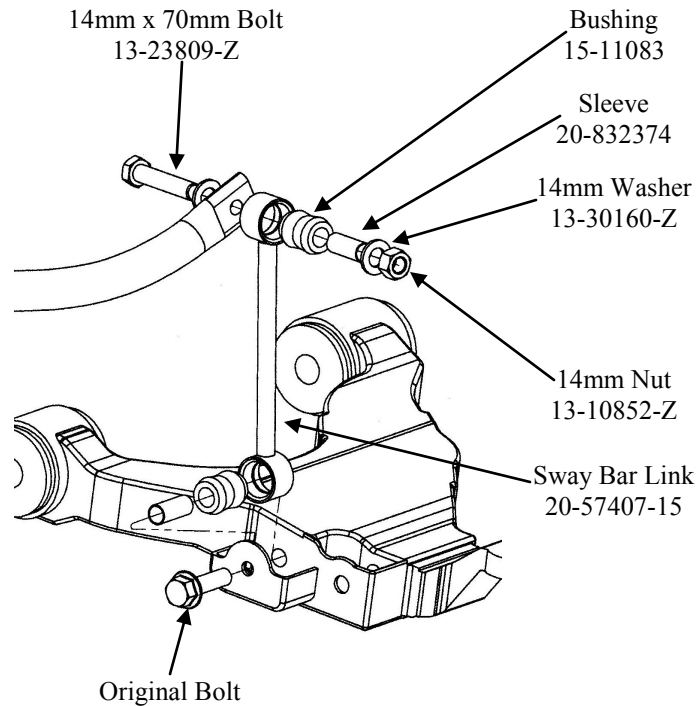
36. Torque axle hub to 275 ft. lbs.

37. Install Anti-sway bar to frame using Sway Bar Relocation Block (RCD 20-57407-8) and hardware provided. (Illustration 15)



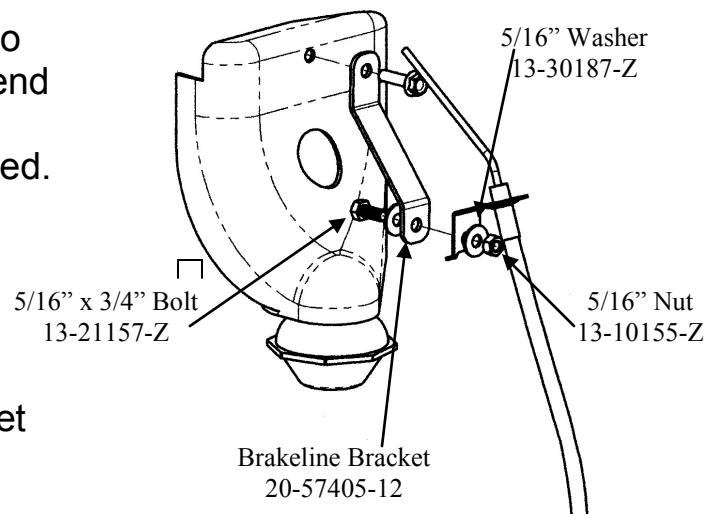
38. Assemble the bushings and sleeves into the Sway Bar End Links (20-57407-15, 20-57407-16). Attach Sway Bar End Links to knuckles using 14mm hardware provided at top and original bolt on bottom. Torque the upper bolt to 75 ft. lbs. and the lower bolt to 85 ft. lbs. (**Illustration 16**)

**Illustration 16**



39. Disconnect Front brakeline mounting bracket at frame and install Front Brakeline Drop (RCD 20-57405-12) to frame using original hardware. Re-bend brakeline to line up with hole in Drop Bracket. Attach with hardware provided. (**Illustration 17**)

**Illustration 17**



40. Install brake rotor. Reattach the front caliper with existing hardware. Torque caliper mounting bracket hex bolts (to spindle) to 85 ft. lbs.

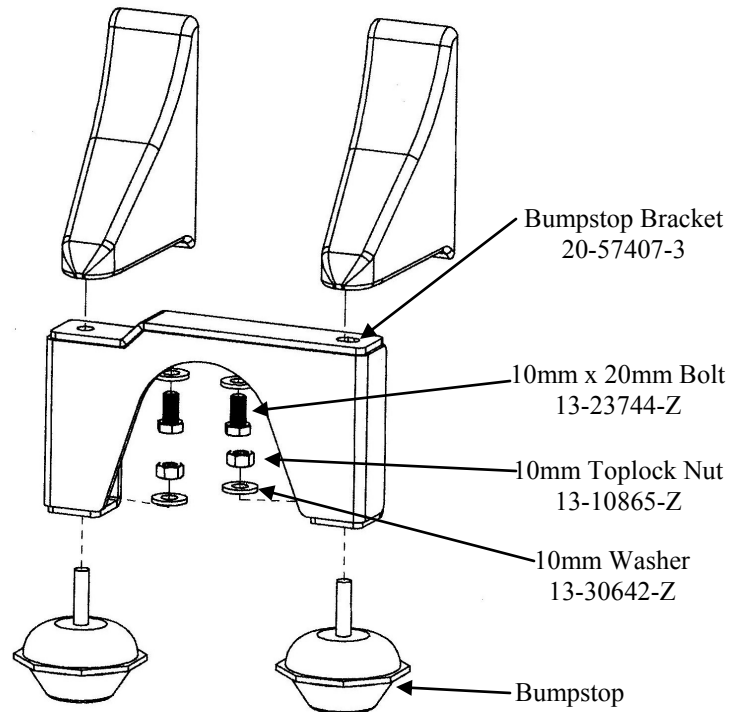
41. Repeat steps 32 thru 42 on opposite side.

42. Unscrew all bumpstops from stock location. Install in holes on both New RCD Bumpstop Extensions (20-57407-3, 20-57407-4). Use 10mm Top Lock Nut and washer provided. **(Illustration 18)**

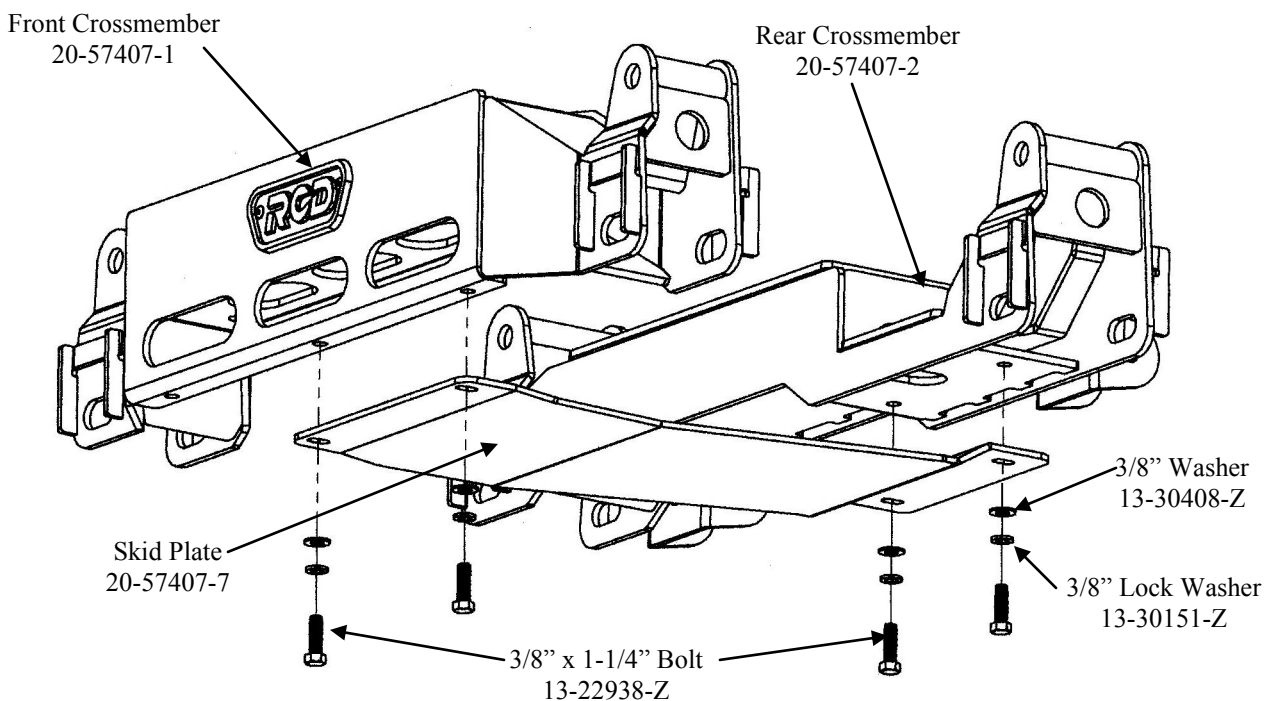
43. Install RCD Bumpstop Brackets to frame using 10mm hardware provided. **(Illustration 18)**

44. Install RCD Skid Plate (20-57407-7) using 3/8" hardware provided. **(Illustration 19)**

**Illustration 18**

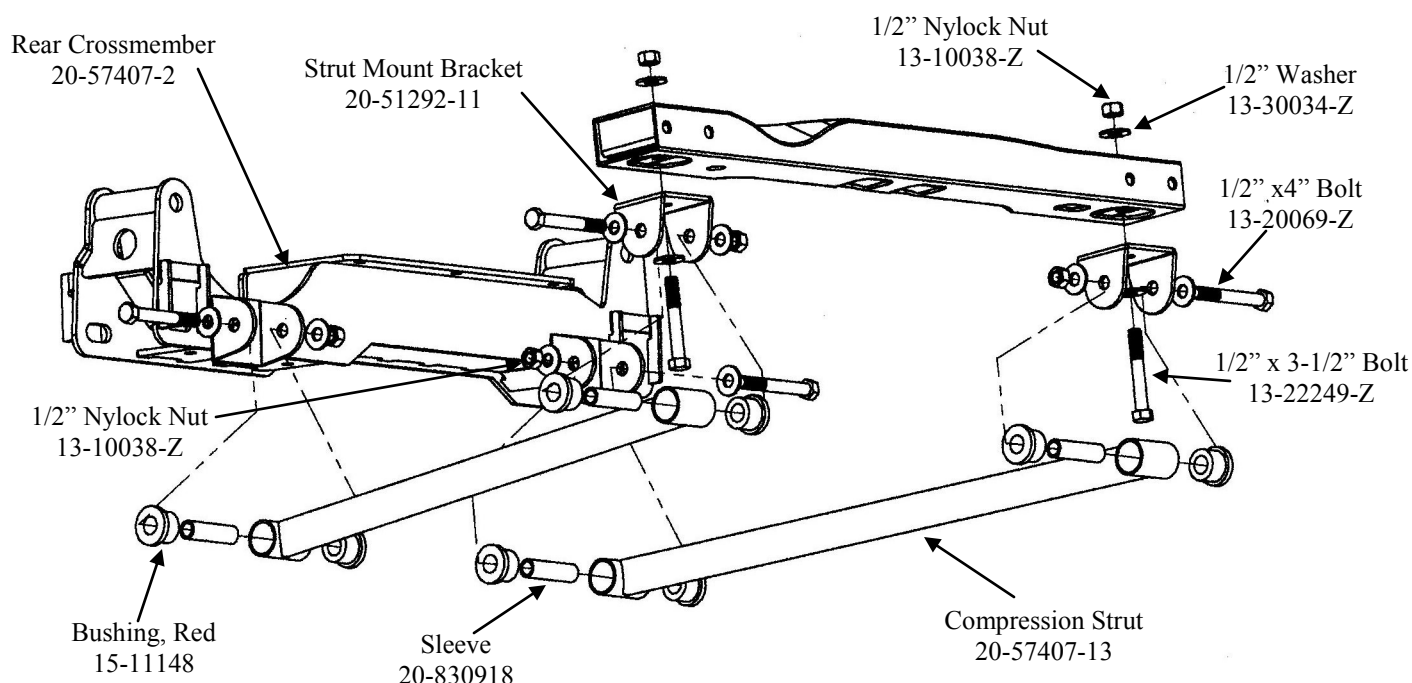


**Illustration 19**





## Illustration 20



45. Install Red Bushings (15-11148) and Sleeves (20-830918) into both ends of the Lateral Compression Struts (20-57407-13). Attach Lateral Compression Strut to Strut Mount bracket located on rear crossmember using hardware provided. **(Illustration 20)**

Do not tighten at this time.

**Note that the struts have a slight offset to them. This offset should go to the outside.**

46. Attach RCD Strut Mount Bracket (20-51292-11) to opposite end of the compression strut. Use a 1/2" drill to open up the hole in the transmission crossmember. Rotate the compression strut assembly upward until bracket contacts the bottom of the transmission crossmember. Install using the 1/2" hardware provided. Torque the nuts to 65 ft. lbs. **(Illustration 20)**

47. Install the wheels and tires, and lower the vehicle to the ground. Torque lug nuts to 83 ft. lbs.

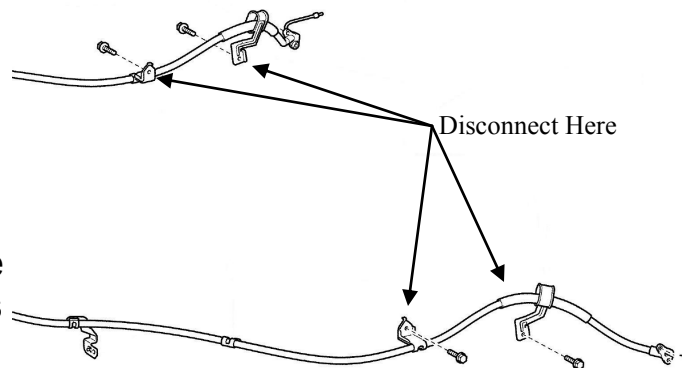
48. When the vehicle is at ride height, torque the lower control arm to front and rear crossmember cam bolts to 145 ft. lbs.

## **Rear Installation Instructions**

1. Raise the vehicle. If working without a shop hoist, support vehicle with suitable safety stands. To do this put vehicle in gear, block front wheels, both in front and behind tires, then disengage emergency brake. Place floor jack underneath rear axle and raise vehicle. Place safety jack stands under frame to support vehicle and lower vehicle onto safety stands. Remove rear tire/wheel assemblies.

**Illustration 21**

2. Disconnect parking brake cables at the leaf spring hanger and also at rear axle spring. **(Illustration 21)**



3. Disconnect bracket where brake hoses attach to rear axle and disconnect the two clamps holding the brakeline on either side of the differential.

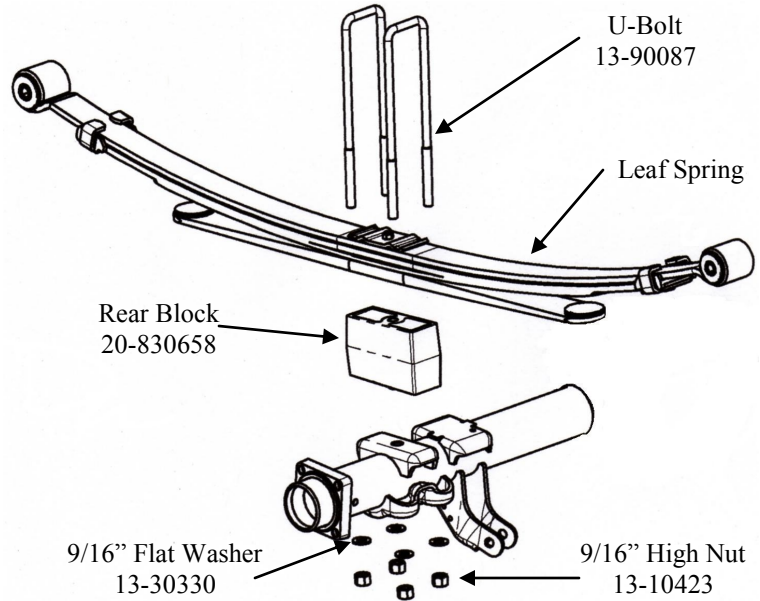
4. Unclamp ABS wires at frame and rear axle.
5. Use a floor jack to raise the rear axle just enough to relieve tension from the shock absorbers and remove them.
6. Remove rear U-bolts attaching rear axle to driver side leaf spring. Carefully lower rear axle.  
**CAUTION: Do not allow axle to hang by any hoses or cables.**

7. Insert new riser Block (RCD 20-830658) on axle pad. Make sure the pin in the block indexes into the hole of the axle housing spring pad. The short end of the block goes toward the front of the vehicle. Carefully

raise rear axle until block makes contact with leaf spring. Make sure center bolt is aligned with the hole in the block (**Illustration 22**).

8. Re-mount axle to spring using the new RCD U-bolts (13-90087), Washers (13-30330) and High Nuts (13-10423) with existing spring plates. Torque U-bolts nuts to 85-100 ft. lbs.

**Illustration 22**



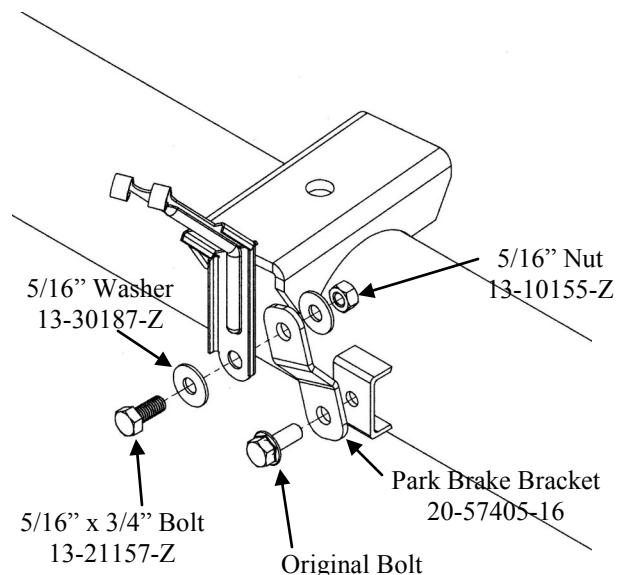
9. **Repeat steps 6 through 8 on passenger side.**

10. Install new longer Shock Absorbers (F4-BE5-E981-T0). Using the existing hardware, attach the shock to the lower axle mount. Attach shock to the upper frame mount and torque the nuts to specifications listed on page 21.

11. Reform brakeline so that hoses point up. Attach to axle with (20-57407-14) at center and (20-57407-17) at either side, using original bolts at axle and 5/16 inch hardware provided at brakeline.

12. Attach RCD Park Brake Cable Relocation Brackets (20-57405-16) to rear axle using original hardware. Attach Park Brake Cables to Brackets using 5/16 inch hardware provided. (**Illustration 23**)

**Illustration 23**

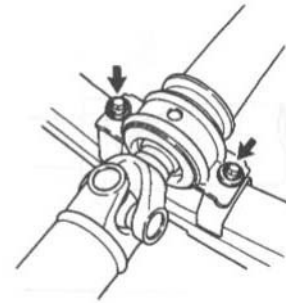


13. Install rear tire/wheel assemblies and lower the vehicle. Torque lug nuts to 83 ft-lbs.

14. If vehicle is equipped with a 2 piece driveshaft using a carrier bearing in the center support drive shaft, remove two bolts clamping the carrier bearing to the crossmember.

**(Illustration 24)** Place 1"OD x 1/2"ID x 1"LG round spacers (RCD 20-833479) between carrier bearing mount and crossmember and re-mount carrier bearing using 10mm x 60mm Hex Bolts with 10mm Flat and Lock Washers.

**Illustration 24**



### ***Some Final Notes***

- After installation is complete, double check that all nuts and bolts are tight. Refer to the torque specifications chart on the last page.
- If new tires are installed that are more than 10% taller than original tires, the speedometer must be recalibrated for the Anti-Lock Brake System to function properly. Contact an Authorized Toyota dealer for details on recalibration.
- With vehicle on the floor, cycle the steering lock to lock and inspect steering, suspension and driveline systems for proper operation, tightness and adequate clearance. Recheck brake/hose fitting for leaks. Be sure all hoses are long enough.
- Have headlights readjusted to proper setting.
- Realign front end to factory specifications. Be sure vehicle is at desired ride height prior to realignment.
- Zero Point Calibration of the VSC system will need to be done after installation and alignment. Please consult a Toyota Factory Service Manual or visit a Toyota Service Department to perform this procedure.

## **Torque Specifications**

### **General Torque Specifications:**

<b>5/16"</b>	<b>20 ft. lbs.</b>	<b>M6</b>	<b>9 ft. lbs.</b>
<b>3/8"</b>	<b>35 ft. lbs.</b>	<b>M8</b>	<b>23 ft. lbs.</b>
<b>7/16"</b>	<b>60 ft. lbs.</b>	<b>M10</b>	<b>45 ft. lbs.</b>
<b>1/2"</b>	<b>90 ft. lbs.</b>	<b>M12</b>	<b>75 ft. lbs.</b>
<b>9/16"</b>	<b>160 ft. lbs.</b>	<b>M14</b>	<b>120 ft. lbs.</b>
<b>5/8"</b>	<b>175 ft. lbs.</b>	<b>M16</b>	<b>165 ft. lbs.</b>
<b>3/4"</b>	<b>250 ft. lbs.</b>	<b>M18</b>	<b>220 ft. lbs.</b>

### **Existing Hardware Torque Specifications:**

Wheel Hub-to-Knuckle Bolts	85 ft. lbs.
Front Differential Mounting Bolts and Nut	95 ft. lbs.
Front Driveshaft/Front Differential Pinion Flange Bolts	65 ft. lbs.
Lower Control Arm Mounting Bolts	145 ft. lbs.
Sway Bar Link Bolts	85 ft. lbs.
Lower Ball Joint Bracket-to-Knuckle Bolts	230 ft. lbs.
Axle Nut	275 ft. lbs.
Upper Ball Joint Nut	67 ft. lbs.
Tie Rod Nut	67 ft. lbs.
Caliper Mount to Steering Knuckle Bolts	91 ft. lbs.
Front Shock, Upper Mount Nuts	47 ft. lbs.
Front Shock, Lower Mount Bolt	150 ft. lbs.
Wheel Lug Nuts	83 ft. lbs.
Rear Shock, Upper Mount Nuts	15 ft. lbs.
Rear Shock, Lower Mount Bolt-to-Nut	74 ft. lbs.
Anti-lock Brake Sensor Bolt	73 in. lbs.