



3/14/07

**1997-2006 JEEP WRANGLER
6" LONG ARM KIT
10-45697
&
10-45697SS**

INSTALLATION INSTRUCTIONS

NOTE: Each lift kit, and options to lift kits, are packaged separately. Therefore installation procedures are covered in separate instructions. Familiarize yourself with each specific set of instructions before beginning.

Part List

<u>Item</u>	<u>Description</u>	<u>Qty.</u>	<u>Illus.</u>
Box 1 of 9			
20-55697-6	Frame Bracket, Pass.	1	14
20-55697-7	Frame Bracket, Drvr.	1	14,15,17
Box 2 of 9			
20-55697-4P	Knuckle,Jeep TJ, Pass.	1	5,9
20-834285	Rod End, Track Bar	1	23
Box 3 of 9			
20-55697-9	Rear Upper Wishbone	1	35
Box 4 of 9			
20-55697-10	Rear Axle Bracket	1	33,34
20-55697-11	Differential Cover Bracket, Drvr.	1	34
20-55697-12	Axle Side Support Bracket, Pass.	1	33,34
20-55697-13	Axle Side Support Bracket, Drvr.	1	33,34
20-55697-14	Weld-in Skidplate Gusset, Pass.	1	14
20-55697-15	Weld-in Skidplate Gusset, Drvr.	1	14,16
20-55697-19	Differential Cover Bracket, Pass.	1	34
20-70164	Hardware Pack: Front Links	1	
13-23536-Z	Hex Bolt, 9/16" x 4" Greaseable	4	20
13-22899-Z	Hex Bolt, 10mm x 90mm Gr. 10.9	2	19
13-23120-Z	Hex Bolt, 7/16" x 3-1/2" Gr. 8	2	19
13-30395-Z	Washer, 9/16" Flat HRDN	8	
13-30642-Z	Washer, 10mm Flat HRDN	4	19
13-30304-Z	Washer, 7/16" Flat HRDN	4	19
13-10930-Z	Jam Nut, 1-1/4"	2	20
13-10904-Z	Jam Nut, 11/16" L/H Thread	1	9
13-10917-Z	Jam Nut, 11/16" R/H Thread	1	9
13-10397-Z	Nut, 9/16" Top Lock	4	
13-10839-Z	Nut, 10mm Top Lock	2	19
13-10384-Z	Nut, 7/16" Top Lock	2	19
13-90815	Cotter Pin	7	
20-70177	Hardware Pack: Rear Links	1	
13-23536-Z	Hex Bolt, 9/16" x 4" Greaseable	5	35
13-23107-Z	Hex Bolt, 9/16" x 4"	2	35
13-30395-Z	Washer, 9/16" Flat HRDN	12	35

13-10930-Z	Jam Nut, 1-1/4"	2	35
13-10397-Z	Nut, 9/16" Top Lock	7	35
15-11187	Bushing, Red	4	35
20-831997	Sleeve, 3/4" x .095w x 3"	2	35
20-70190	Hardware Pack: Rear Axle Mounts	1	
20-834311	Spacer, 1-1/2" x 7/16" id x 2"	2	33
20-834207	Washer, Rear Axle Caster Block	4	33,34
13-22899-Z	Hex Bolt, 10mm x 90mm Gr. 10.9	2	33,34
13-23549-Z	Hex Bolt, 10mm x 35mm Gr. 10.9	4	33
13-22938-Z	Hex Bolt, 3/8" x 1-1/4" Gr. 8	8	33,34
13-23341-Z	Hex Bolt, 5/16" x 1" Gr. 8	7	34
13-30642-Z	Washer, 10mm Flat HRDN	8	33,34
13-30577-Z	Washer, 10mm Split Lock	4	33
13-30408-Z	Washer, 3/8" Flat HRDN	16	33,34
13-30525-Z	Washer, 5/16" Split Lock	7	34
13-10839-Z	Nut, 10mm Top Lock	2	33
13-10553-Z	Nut, 3/8" Top Lock	8	34
20-70203	Hardware Pack: Frame Brackets	1	
13-23562-Z	Hex Bolt, 12mm x 35mm	8	14
13-21001-Z	Hex Bolt, 3/8" x 4" Gr. 8	14	14
13-22301-Z	Hex Bolt, 1/4" x 3/4"	1	
13-30546-Z	Washer, 12mm Flat HRDN	8	14
13-30460-Z	Washer, 12mm Split Lock	8	14
13-30382-Z	Washer, 1/2" Flat HRDN	6	
13-30408-Z	Washer, 3/8" Flat HRDN	28	14
13-30195-Z	Washer, 1/4" Flat	2	
13-10553-Z	Nut, 3/8" Top Lock	14	14
13-10161-Z	Nut, 1/4" Nyloc	1	
20-70216	Hardware Pack: Front Sway Bar Links	1	
20-834051	Sway Bar Link, Upper Assembly	2	25
20-834064	Sway Bar Link, Lower Loop	2	25
20-834090	Sway Bar Link, Center Tube	2	25
13-30694-Z	Washer, 1-1/4" od x 1/2" id	4	25
13-10878-Z	Nut, 1/2" Nyloc	2	25
15-11746	Bushing, Sway Bar Flex Joint	4	25
15-11083	Bushing, Hour Glass	2	25
20-831451	Sleeve, 5/8" x 1-1/2"	2	25
13-90984	Pin, Safety	4	25
20-70577	Hardware Pack: Bumpstop Extensions	1	
20-55497-2	Bumpstop Pad	4	21
15-11772	Bumpstop, Black	4	22
13-22145-Z	Hex Bolt, 3/8" x 2" Self Tapping	4	21
20-70590	Hardware Pack: Rear Sway Bar Links	1	
20-55697-16	Rear Sway Bar Link	2	37
20-832374	Sleeve, 5/8" x 1-1/2"	4	37
15-11083	Bushing, Hour Glass	4	37
20-70603	Hardware Pack: Front Brakelines	1	
50-55697-1	Front Brake Line	2	
50-55697-2	Brake Line Bracket	2	
50-55697-3	Brake Line Screw, Self Tapping	2	

50-5700-2	Brake Line Clip	2	
50-5700-4	Brake Line Crush Washer	4	
20-68305	Hardware Pack: Misc.	1	
13-20447-Z	Screws for Brakeline Clamps	4	
15-10966	Brake Line Clamps	4	
15-11395	Zip Tie, 6"	4	
15-11447	Zip Tie, 8"	2	
15-11460	Zip Tie, 11"	2	

Box 5 of 9 (10-45697)

20-55697-1	Front Lower Link	2	18,20
20-55697-8	Rear Lower Link	2	18,35
20-55697-18	Lower Link Adjuster	4	18,20,35

Box 5 of 9 (10-45697SS)

20-55697-20	Front Lower Link, Stainless Steel	2	18,20
20-55697-21	Rear Lower Link, Stainless Steel	2	18,35
20-55697-18	Lower Link Adjuster	4	18,20,35

Box 6 of 9

20-55697-2	Front Upper Link, Drvr	1	19
20-55697-3	Tie Rod	1	9
20-55697-5	Front Track Bar	1	23
20-55697-17	Front Upper Link, Pass	1	

Box 8 of 9

20-20322-1	Coil Spring, Front	2	
------------	--------------------	---	--

Box 8 of 9

20-20335-1	Coil Spring, Rear	2	
------------	-------------------	---	--

Box 9 of 9

50-BE5-C016-T0	Front Shock	2	24
50-BE5-C017-T0	Rear Shock	2	38

INTRODUCTION

Installation by a professional mechanic is recommended. Use of the appropriate tools, a Jeep service manual, and a shop hoist can greatly reduce installation time.

Prior to installation, carefully inspect the vehicle's steering and drive train systems, paying close attention to the tie-rod ends, steering box, and ball joints. Also check steering-to-frame and suspension-to-frame attachment points for stress cracks. The overall vehicle must be in excellent working condition; repair or replace worn parts.

Read instructions carefully and study illustrations before attempting installation. **RCD Suspension** is not responsible for damage, failure or injury resulting from improper installation or parts substitution of this kit.

Check parts and hardware against the parts list to assure that your kit is complete. Report any shortages to RCD Suspension at (1-619-588-4723). The parts and hardware supplied are of high-grade material and must not be replaced by inferior parts or failure may result. Do not begin installation if parts are missing.

Separate parts according to the areas they will be used. Placing the hardware with brackets before you begin will save installation time.

This kit is supplied as a bolt-on assembly. Do not weld anything to the components and do not weld the components to the vehicle, unless specified.

All components in this kit come with a protective coating. Do not plate (i.e. chrome, cadmium, zinc etc.) or otherwise alter the finish in any way. This could decrease the structural strength of the components.

Secure and properly block vehicle prior to beginning installation.

Always wear safety glasses when using power tools.

Foot-Pound torque readings are listed on the Torque Specifications chart at the end of the instructions unless specifically stated in an instruction. **DO NOT USE AN IMPACT WRENCH TO TIGHTEN ANY OF THE BOLTS.**

PLEASE NOTE

Actual lift / ride height may vary based on vehicle configuration and equipment (i.e., soft / hard top, winch, bumpers, etc.)

This kit requires the use of a slip-yoke-eliminator kit and new rear driveshaft. A new exhaust system will also need to be fabricated.

WARNING: DO NOT USE WHEEL SPACERS

Front-end realignment is necessary.

Speedometer recalibration is necessary if larger tires (10% more than stock diameter) are installed.

Brake system will need to be bled by a professional brake technician.

System is designed to accommodate up to a 33" x 12.5" tire on a wheel size of 15" x 8" with a maximum of 3-5/8" backspacing.

Special tools are required for safe removal and installation of the ball joints, & tie-rods. These tools can be purchased from your Jeep Dealer.

Tie Rod Puller(P/N C-3894-A)

Front Installation Instructions

1. Raise the front of the vehicle. If working without a shop hoist, support vehicle with suitable safety jack stands. Put vehicle in gear, set emergency brake and block rear wheels, both in front and behind tires. Loosen front wheel lug nuts. Place floor jack under the front axle and raise vehicle. Place safety jack stands under frame rails, just behind front bumper, and lower the frame onto the stands. Remove wheels.
2. Using a suitable floor jack, raise the jack just enough to support the weight of the front axle. Remove the sway bar end links. **(Illustration 1)**
3. Disconnect the Track Bar from the Frame. **(Illustration 8)**
4. Disconnect and remove Tie Rod from Drag Link and Left Knuckle. **(Illustration 2)**
5. Disconnect Drag Link from Right Knuckle. **(Illustration 2)**
6. Locate and remove the two bolts attaching each Brake Caliper to the Steering Knuckles. Remove the Calipers and hang out of the way with a length of wire, careful not to damage the brake lines. **DO NOT let the Calipers hang by the brake lines.**
7. Remove the Passenger side Brake Rotor only. **(Illustration 3)**
8. Remove the Pass side Axle Nut. **(Illustration 4)**

Illustration 1

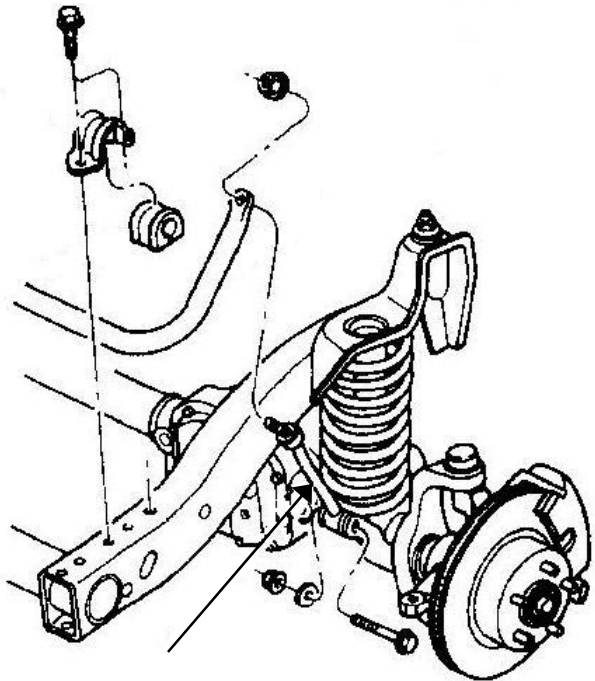

Illustration 2

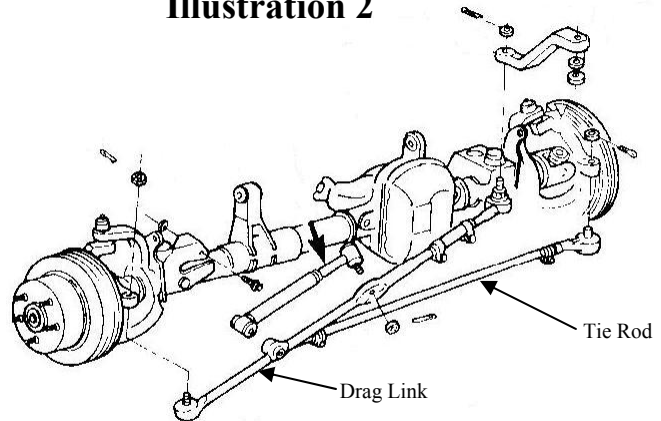
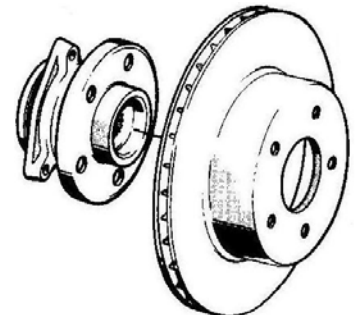

Illustration 3



9. Remove the 3 Hub to Knuckle bolts. Remove the hub and Disc Brake Shield from the Steering Knuckle and Axle Shaft. **(Illustration 4)**

10. Remove the Axle Shaft from the housing. **(Illustration 5)**

11. If equipped with ABS Sensor, disconnect from Steering Knuckle at this time. **(Illustration 6)**

12. Remove the Upper and Lower Ball Stud nuts.

13. Strike the Steering Knuckle with a brass hammer to loosen. Remove knuckle from axle tube yokes. **(Illustration 7)**

14. Remove steering stop bolt from old knuckle and install in new RCD Steering Knuckle (20-55697-4P).

15. Install RCD Steering Knuckle (20-55697-4P) on Ball Studs. Install and tighten the retaining nuts. Torque the lower nut to 80lb/ft. and the upper nut to 75lb/ft. **(Illustration 7)**

16. Install the Axle Shaft into the housing.

17. If equipped with ABS Sensor, connect it at this time. **(Illustration 6)**

18. Install the Hub Bearing and Brake Dust Shield to the Knuckle. Install the Hub to Knuckle bolts and torque to 75 lb/ft. **(Illustration 4)**

19. Install the Hub Washer and Nut. Torque to 175lb/ft. Install the Nut Retainer and Cotter Pin. **(Illustration 4)**

20. Install Brake Rotor. **(Illustration 3)**

Illustration 4

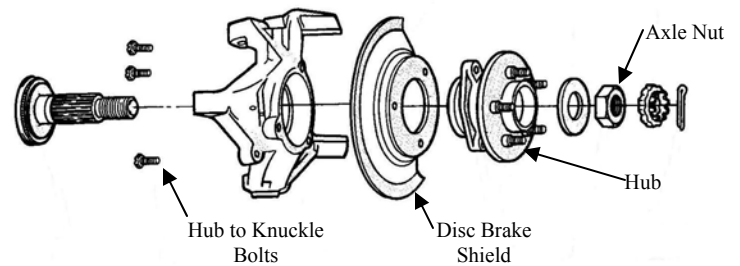

Illustration 5

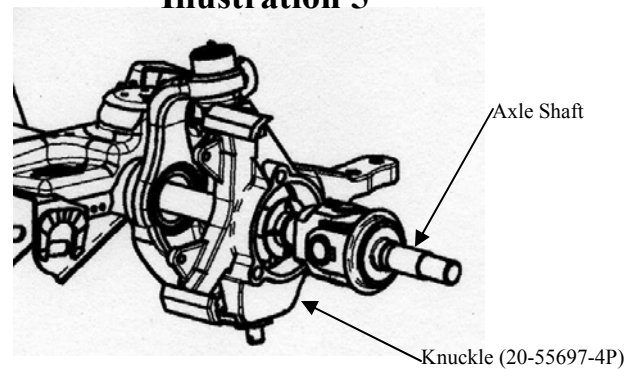

Illustration 6

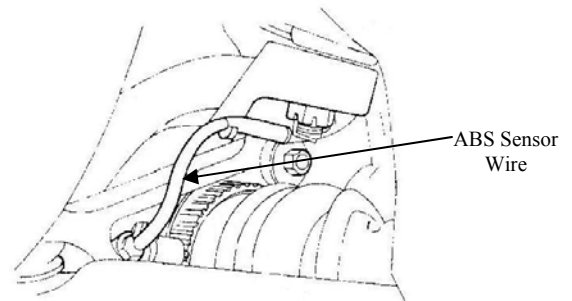
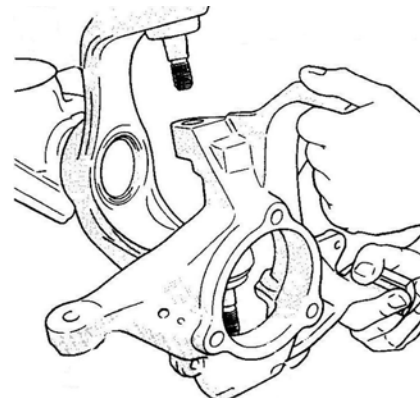

Illustration 7



21. Disconnect and remove Front Track Bar from Front Axle. **(Illustration 8)**
22. Remove Tie Rod Ends from previously removed Tie Rod.
23. Locate the Jam Nuts (13-10904-Z, and 13-10917-Z) and install on Tie Rod Ends, then thread Ends into new Tie Rod **(Illustration 9)**
Note that the ends are left and right hand thread.

Illustration 8

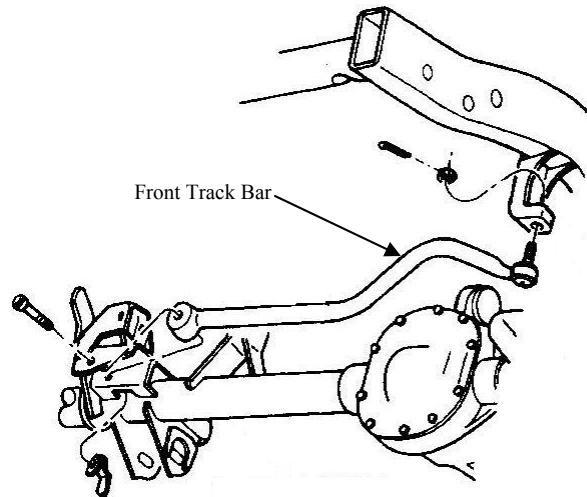
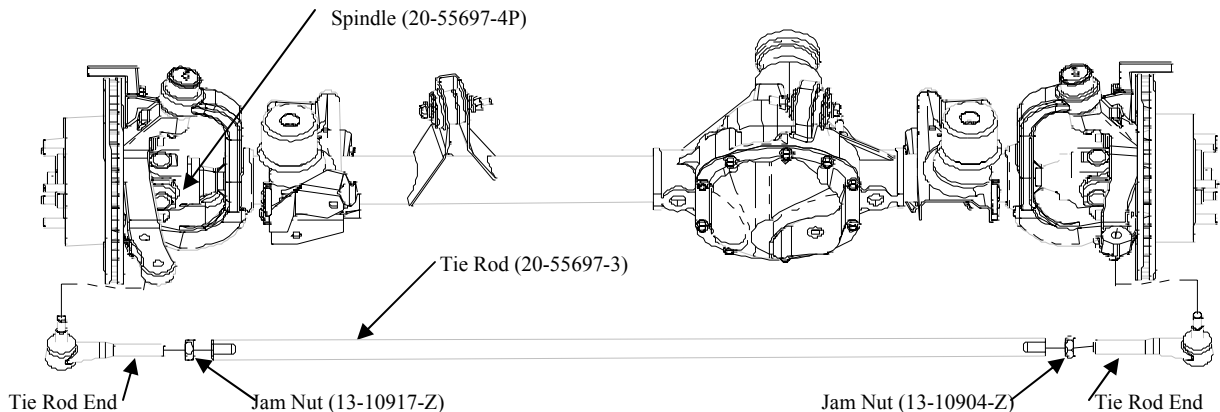
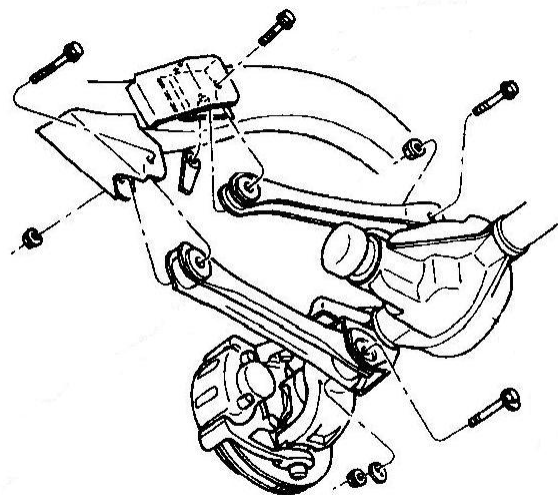

Illustration 9



24. Install new Tie Rod assembly between the Left and Right Steering Knuckles. The Tie Rod attaches to the inner hole on the Passenger side Knuckle. Torque the nuts to 35 lb/ft. Install Cotter Pins. **(Illustration 9)**
25. Remove Front Shocks and then lower Front Axle until Springs are free from upper mount. Remove Coil Spring Retainer and remove Springs.
26. Place safety jack stands under Front Axle and lower Axle onto stands.
27. Remove the 4 Front Upper and Lower Control Arms. **(Illustration 10)**

Illustration 10



28. Place floor jack under transmission and raise until weight is off of the transmission mount.

29. Remove auxiliary transmission skid plate, if equipped.

30. Remove Skid Plate. (**Illustration 11**)

31. Remove the exhaust system.

(**Illustration 12**)

It will be necessary to have the exhaust system modified to clear the upper control arms after installation.

Illustration 11

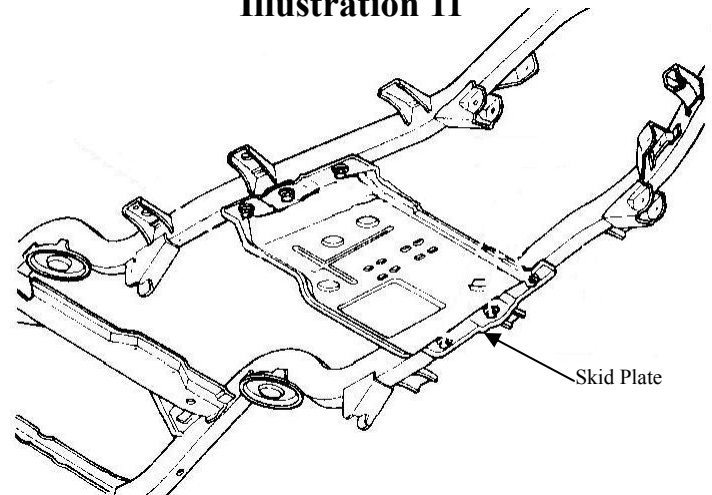

Illustration 12

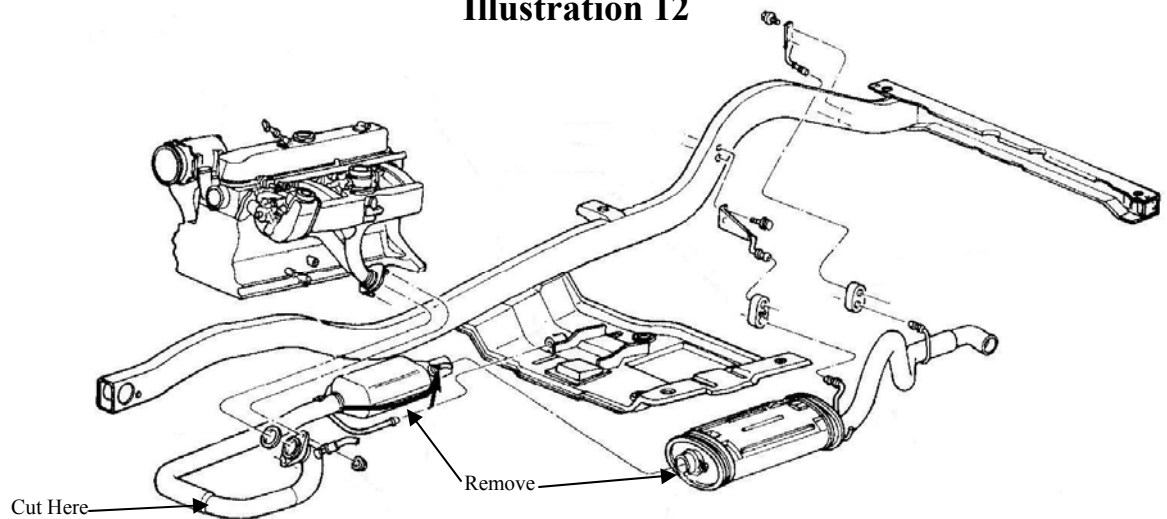

Illustration 13

32. If equipped with side steps, remove them at this time.

33. Cut front upper and lower Control Arm Brackets off of frame. Remove the entire lower bracket and grind smooth.

(**Illustration 13**) The upper bracket only needs to be partially removed. Paint all bare metal.

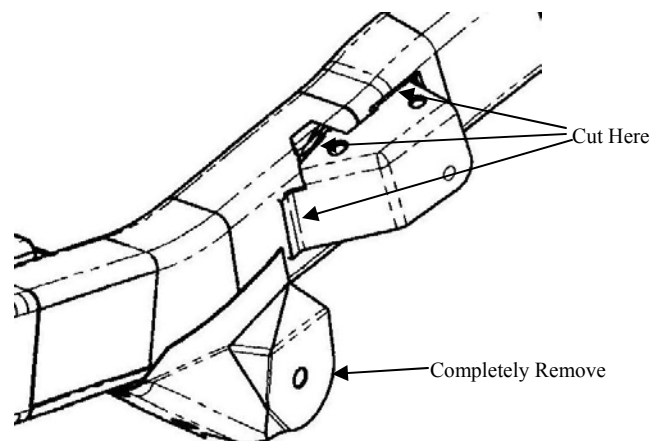
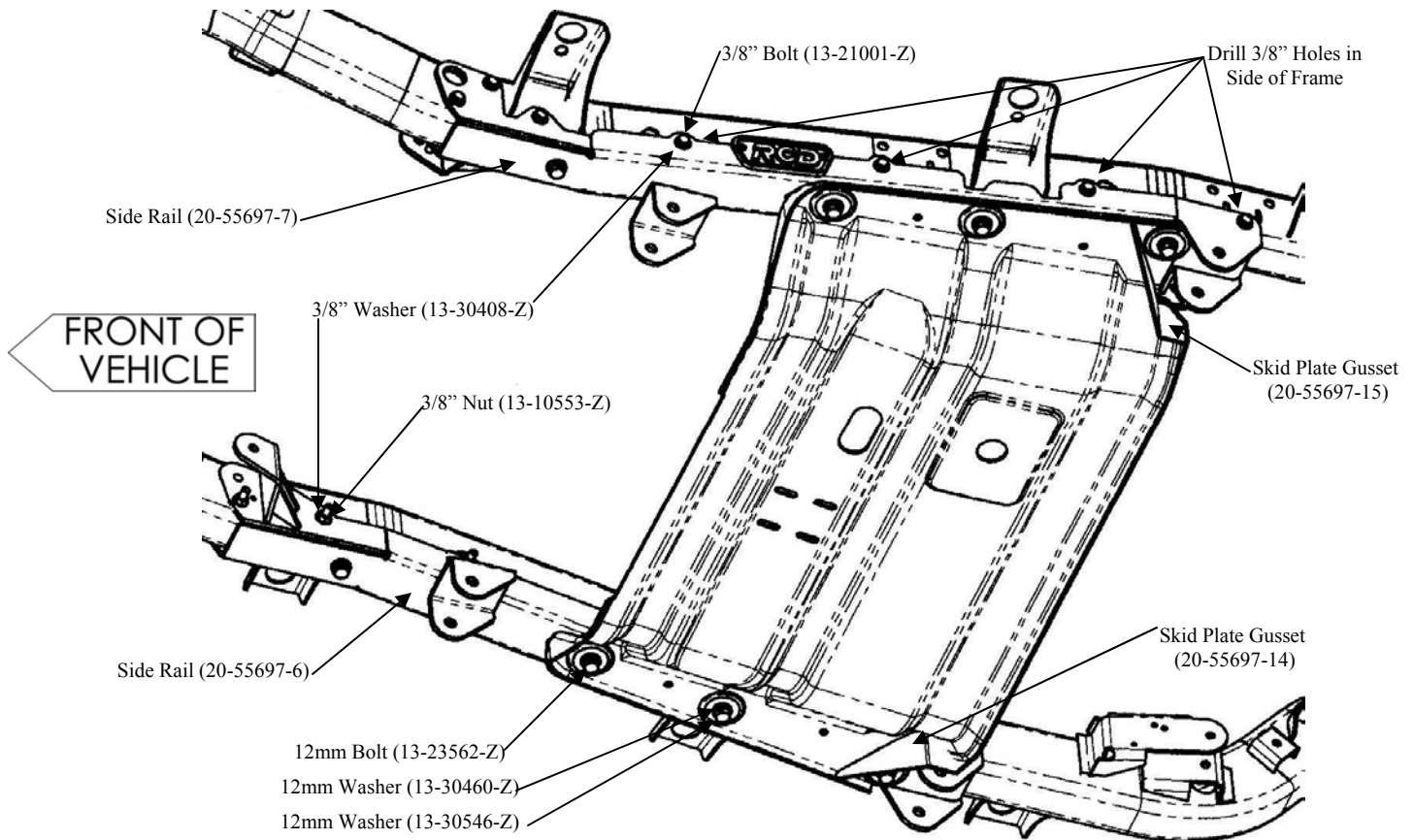

Illustration 14



34. Fit new Side Rails (20-55697-6, and 20-55697-7) to Frame. **(Illustration 14)** There is a $\frac{1}{4}$ " hole in the Side Rails at the front inside. This hole lines up with a hole in the Frame. **(Illustration 15)** Drill seven $\frac{3}{8}$ " holes through each side of Frame.

35. Install, but don't tighten, $\frac{3}{8}$ " bolts through side of frame.

36. Notch Skid Plate, and weld in gussets (20-55697-14, and 20-55697-15) as shown. **(Illustration 16)** Paint all bare metal.

37. Install Skid Plate over Side Rails. Using 12mm x 35mm bolts, lock washers, and flat washers. Be sure to place $\frac{1}{2}$ " washers between Skid Plate and Side Rails. Tighten all Side Rail hardware at this time. **(Illustration 14)**

Illustration 15

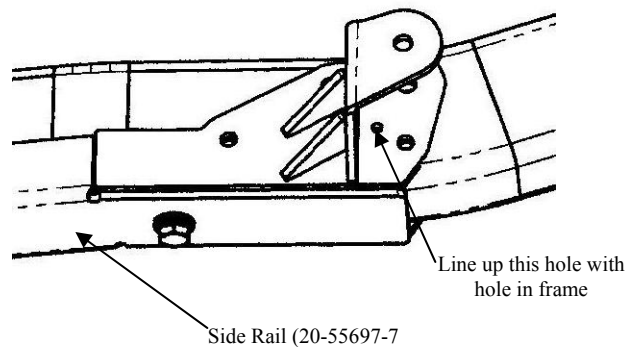

Illustration 16

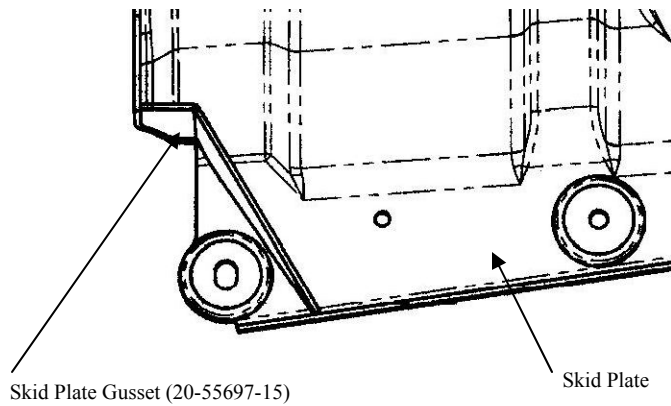
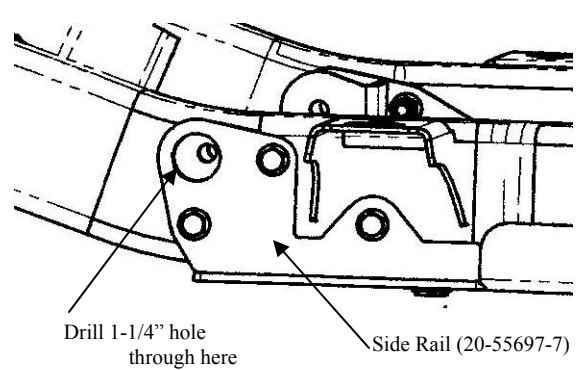

Illustration 17



38. Lower Transmission onto Skid Plate and secure with original hardware.

39. At front outside of Side Rails drill a 1-1/4" hole through the existing hole in Side Rail. Drill a 7/16 hole through the inner wall of the frame that lines up with hole in inner bracket. (Illustration 17)

40. Assemble the Lower Control Arms. (Illustration 18)

Illustration 18

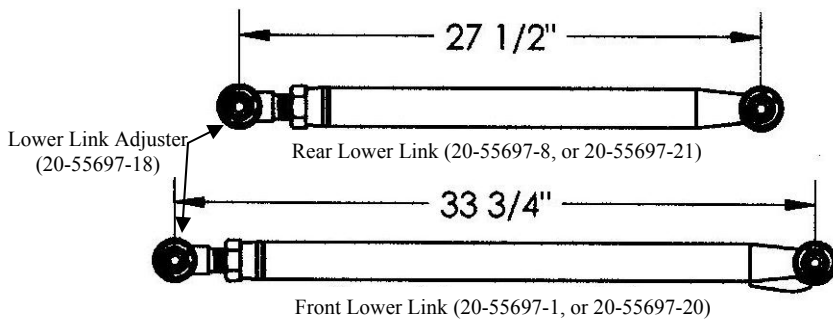
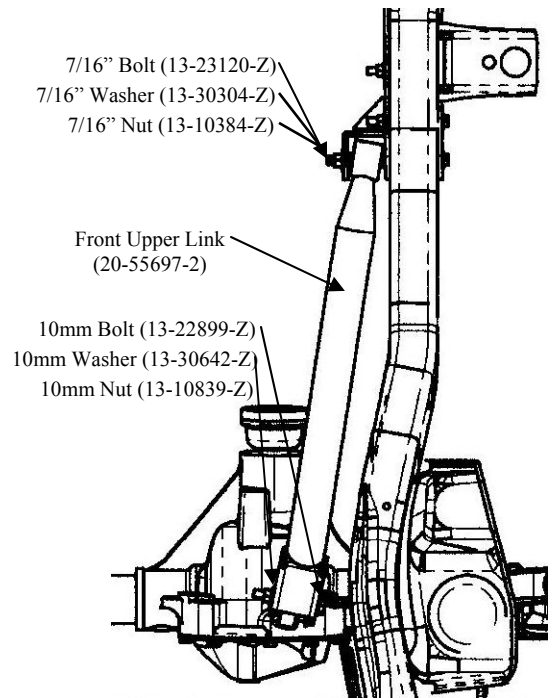
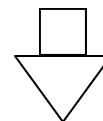

Illustration 19



41. Install Front Upper Links (20-55697-2, and 20-55697-17) using 10mm x 90mm bolt at the front and 7/16" x 3-1/2" bolt at rear. (Illustration 19)

FRONT



42. Install Front Lower Links (20-55697-1 or 20-55697-20 if installing the Stainless Steel kit) using 9/16" x 4" greaseable bolts. **(Illustration 20)**

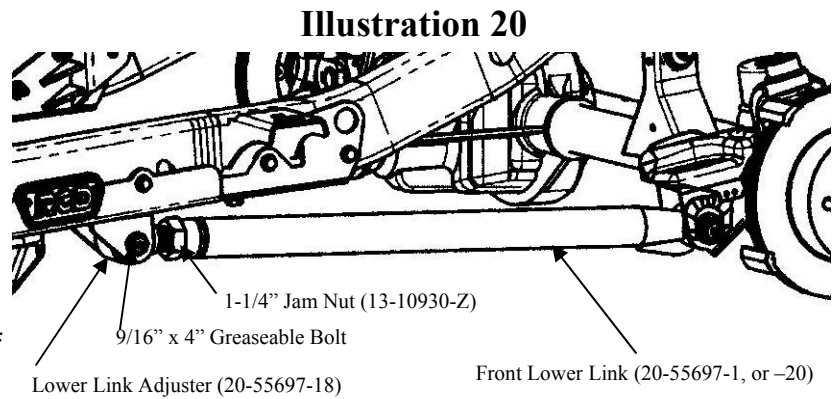

43. Install new Bump Stop Pad (20-55497-2) as shown in **(Illustration 21)**. Mark center of lower coil spring pad. Using an 11/32" diameter drill bit, drill a pilot hole in the previously marked area. Install using 3/8" self-tapping hardware provided. Torque to 30 lb/ft.

44. Remove upper rubber bump stops.

45. Install new Upper Bump Stops (15-11772). **(Illustration 22)**

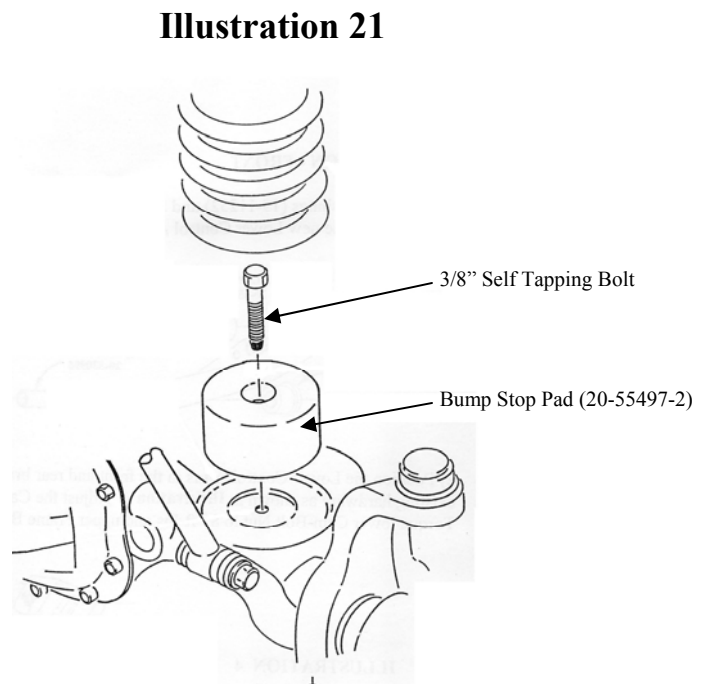
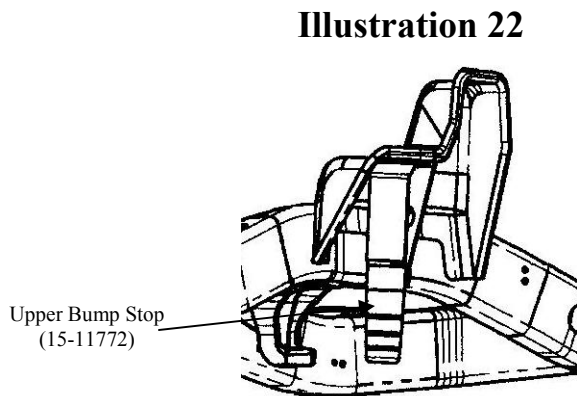

46. Install new Front Coil Springs (20-20322-1) on axle pad. Re-install Coil Spring Retainer and bolt. Torque to 16 lb/ft.

47. Install Rod End (20-834285) with jam nut into Front Track Bar (20-55697-5) and install with Rod End to Frame and bushing end at Front Axle. **(Illustration 23)**

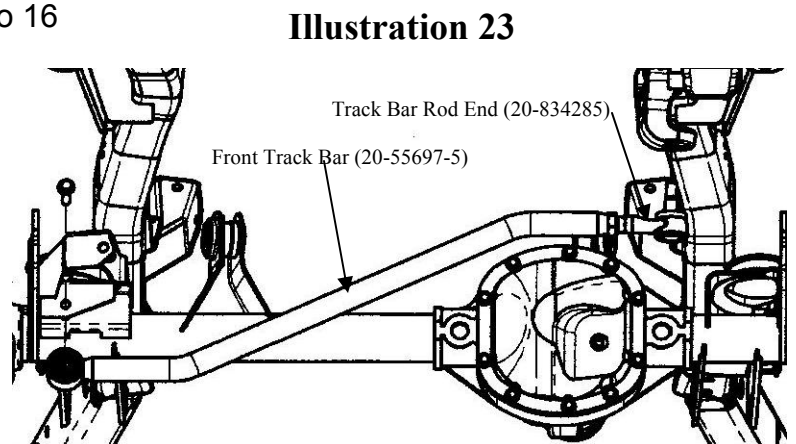

48. Attach Drag Link to Passenger Side Knuckle.

49. Install Front Shocks (50-BE5-C016-T0).
(Illustration 24)

50. Re-install Front Brake Calipers. It may be necessary to disconnect the brake hoses to do this.

51. Install new Brake Lines (50-55697-1) with angle bracket, clip, and crush washers supplied. Attach Angle Bracket with original bolt.
Check to make sure that Brake Line Clears all components when wheels are turned and suspension is compressed.

52. Assemble Front Sway Bar Links.
(Illustration 25)

53. Using a 1/2" diameter drill bit, drill out the Sway Bar to accept the Sway Bar Link. **(Illustration 26)**

54. Install Sway Bar Links to Sway Bar with hardware supplied, and Front Axle using original hardware.

55. Bleed the brakes, checking for leaks at the newly installed fittings. Install the wheels and tires, and lower the vehicle to the ground. Torque lug nuts to 80 lb/ft.

Illustration 24

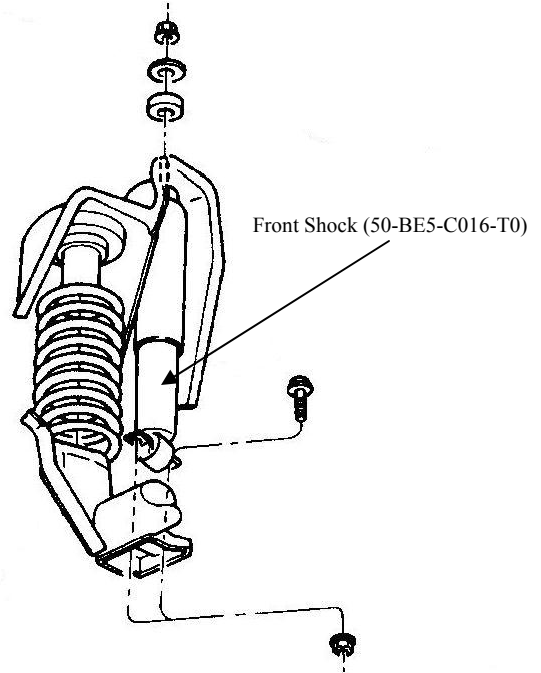

Illustration 25

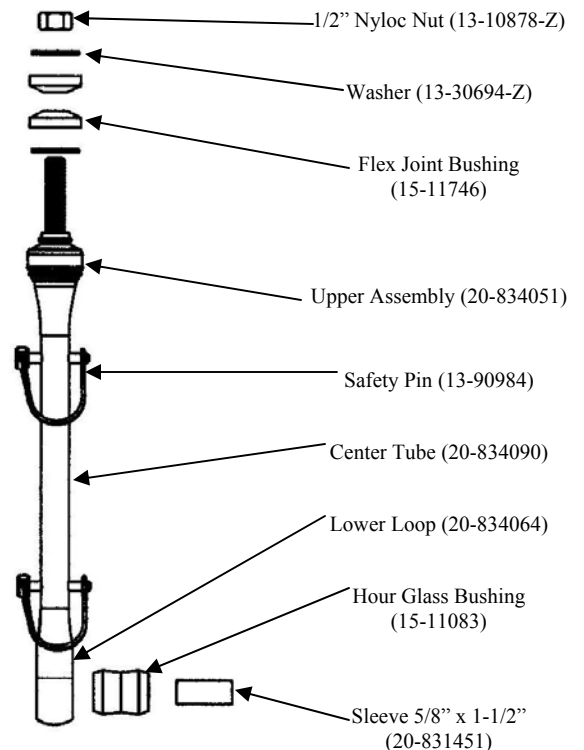
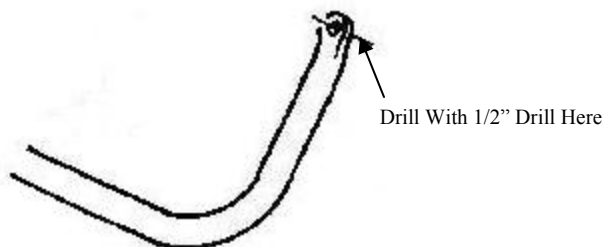

Illustration 26



Rear Installation

1. Raise the rear of the vehicle. If working without a shop hoist, support vehicle with suitable safety jack stands. Block front wheels, both in front and behind tires. Loosen rear wheel lug nuts. Place floor jack under the rear axle and raise vehicle. Place safety jack stands under frame rails, at rear end of skid plate, and lower the frame onto the stands. Remove rear wheels.
2. Using a suitable floor jack, raise the jack just enough to support the rear axle's weight.
3. Locate and remove the rear sway bar end links. (**Illustration 27**)
4. Remove rear Track Bar. (**Illustration 28**)
5. Remove rear shocks. (**Illustration 29**)
6. Disconnect Driveshaft from Rear Differential.
7. Disconnect Rear Brake Line mounting bracket from frame. Also disconnect Rear Brake Line where it attaches to the Upper Control arm. (**Illustration 30**)
8. Lower Rear Axle until springs are free from upper mount. Remove Rear Springs.
9. Place safety jack stands under Rear Axle and lower Axle onto stands.
10. Disconnect and remove all 4 Rear Control Arms. (**Illustrations 31 & 32**)
11. Remove Rear Sway Bar from Rear Axle. (**Illustration 27**)

Illustration 27

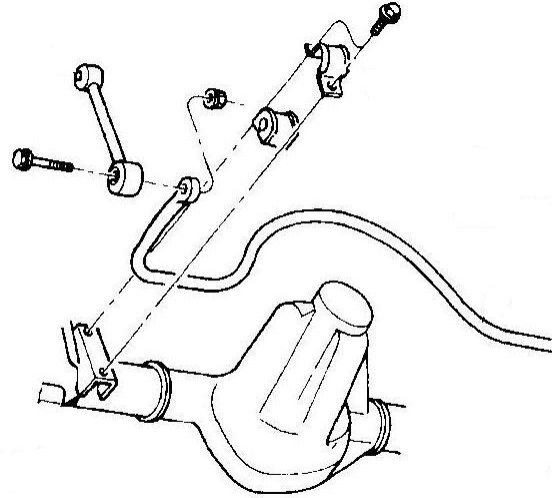

Illustration 28

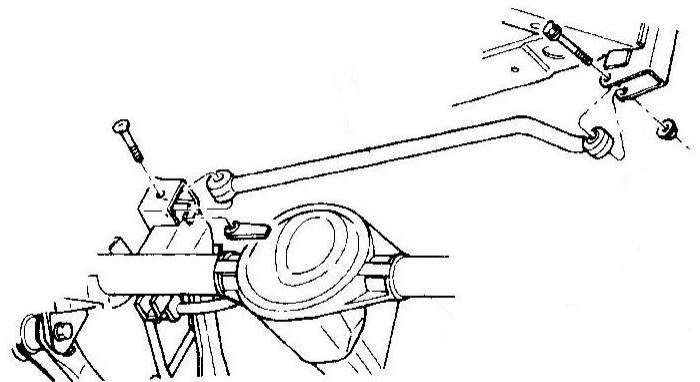
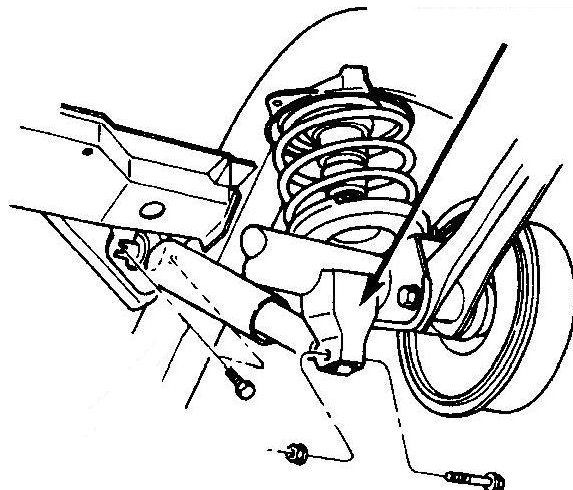

Illustration 29



12. Install Rear Axle Bracket (20-55697-10) to Rear Axle Using Hardware Provided. **(Illustration 33)** Be sure to re-install Rear Sway Bar to Rear Axle.

13. Remove the two outer Differential Cover Bolts on either side of cover.

14. Install Rear Differential Cover Brackets (20-55697-11, 20-55697-19) as shown, using hardware provided. **(Illustration 34)** The brackets are designed to fit with either the Dana 35 or 44.

15. Install the red bushings and sleeves into the Rear Upper Link then install Rear Upper Link (20-55697-9) using two 9/16" x 4" bolts at front and one 9/16" x 4" greaseable bolt at the center rear. Torque to 160 lb/ft. **(Illustration 35)**

16. Install new Bumpstop Pads (20-55497-2) in the same manner as the fronts were installed.

17. Cut rear lower Control Arm Brackets off of frame. Remove the entire lower bracket and grind smooth. **(Illustration 13)** Paint all bare metal.

18. Install Lower Control Arms (20-55697-8 or 20-55697-21 if installing the Stainless Steel kit) using four 9/16" x 4" greaseable bolts. Torque to 160 lb/ft. **(Illustration 35)**

19. Remove upper rubber bump stops.

20. Install new Upper Bump Stops (15-11772).

21. Install new Rear Springs (20-20335-1).

22. Drill a 1/4" hole in Rear Upper Frame Bracket as shown, and attach Brake Line at this point. **(Illustration 36)**

Illustration 30

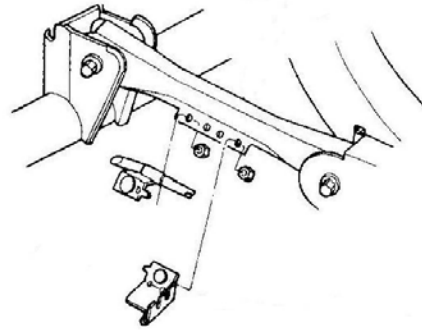

Illustration 31

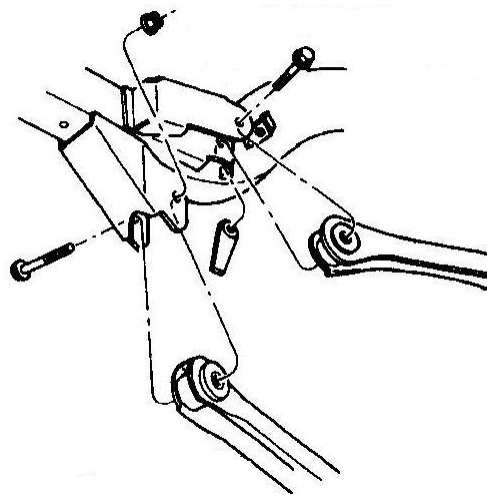

Illustration 32

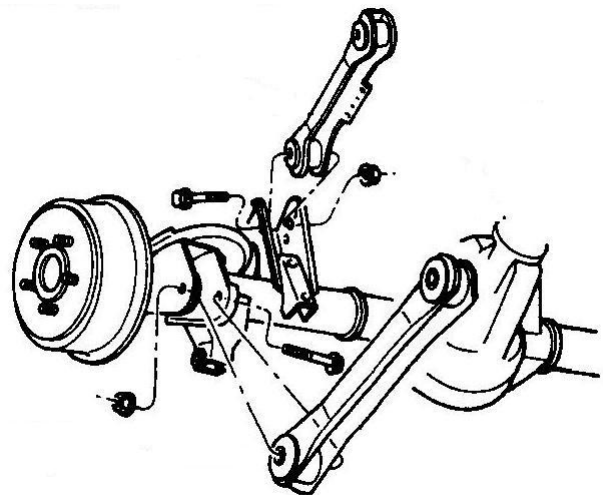

Illustration 33

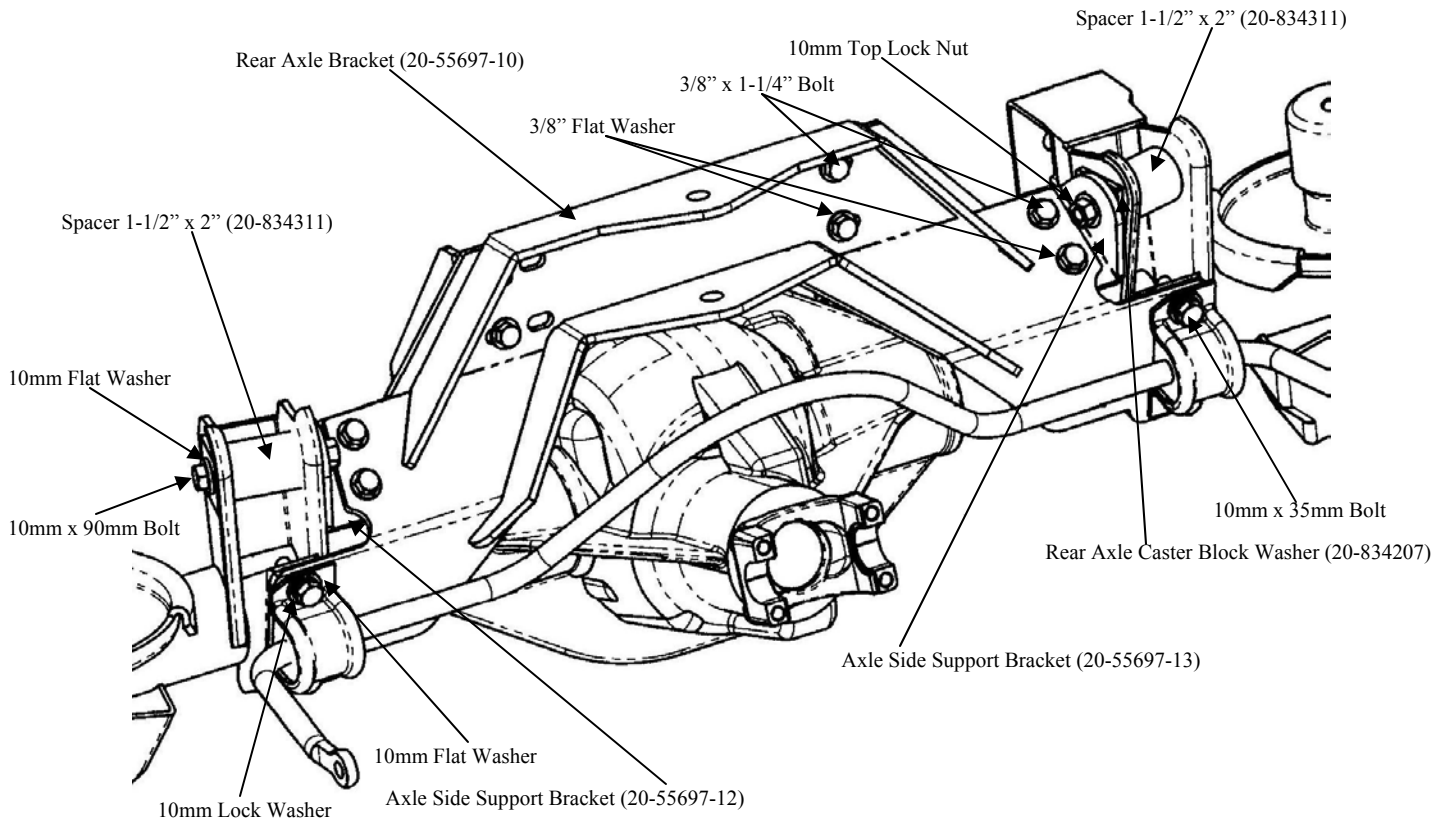

Illustration 34

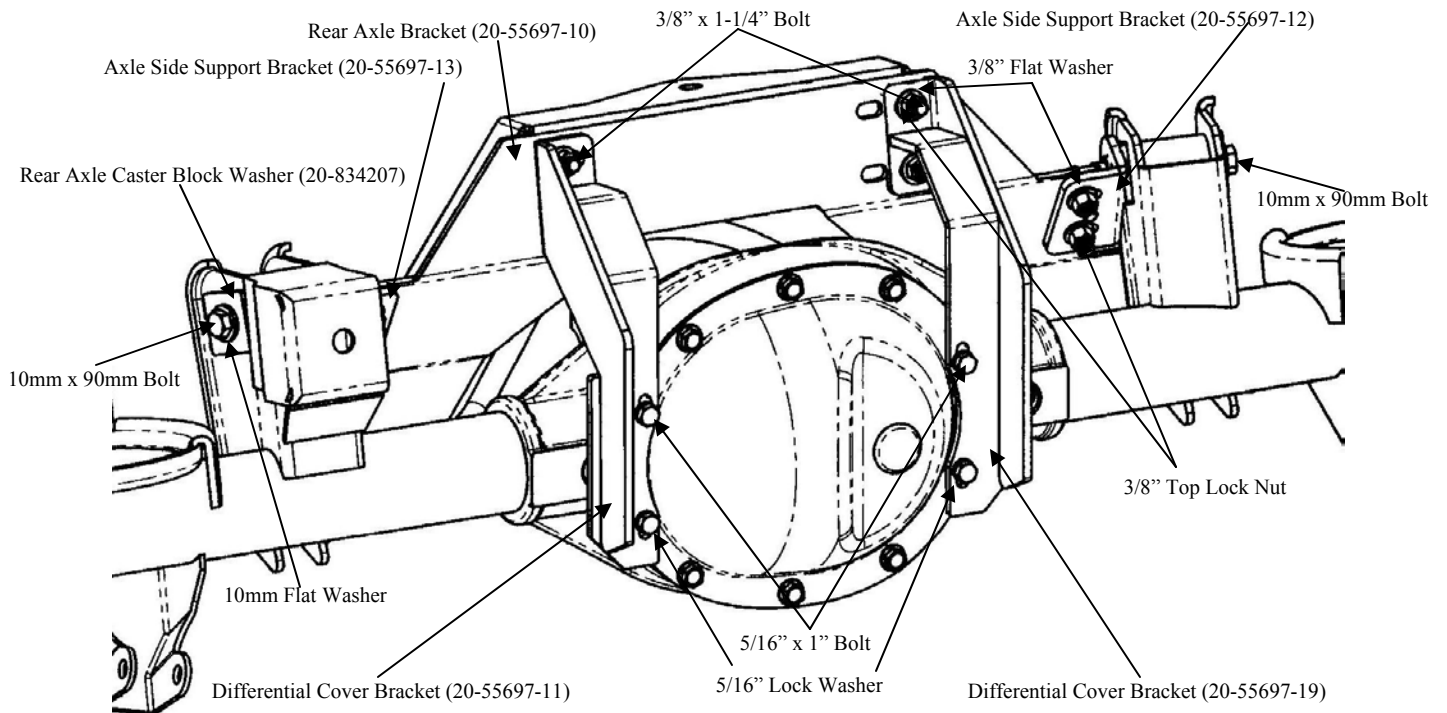
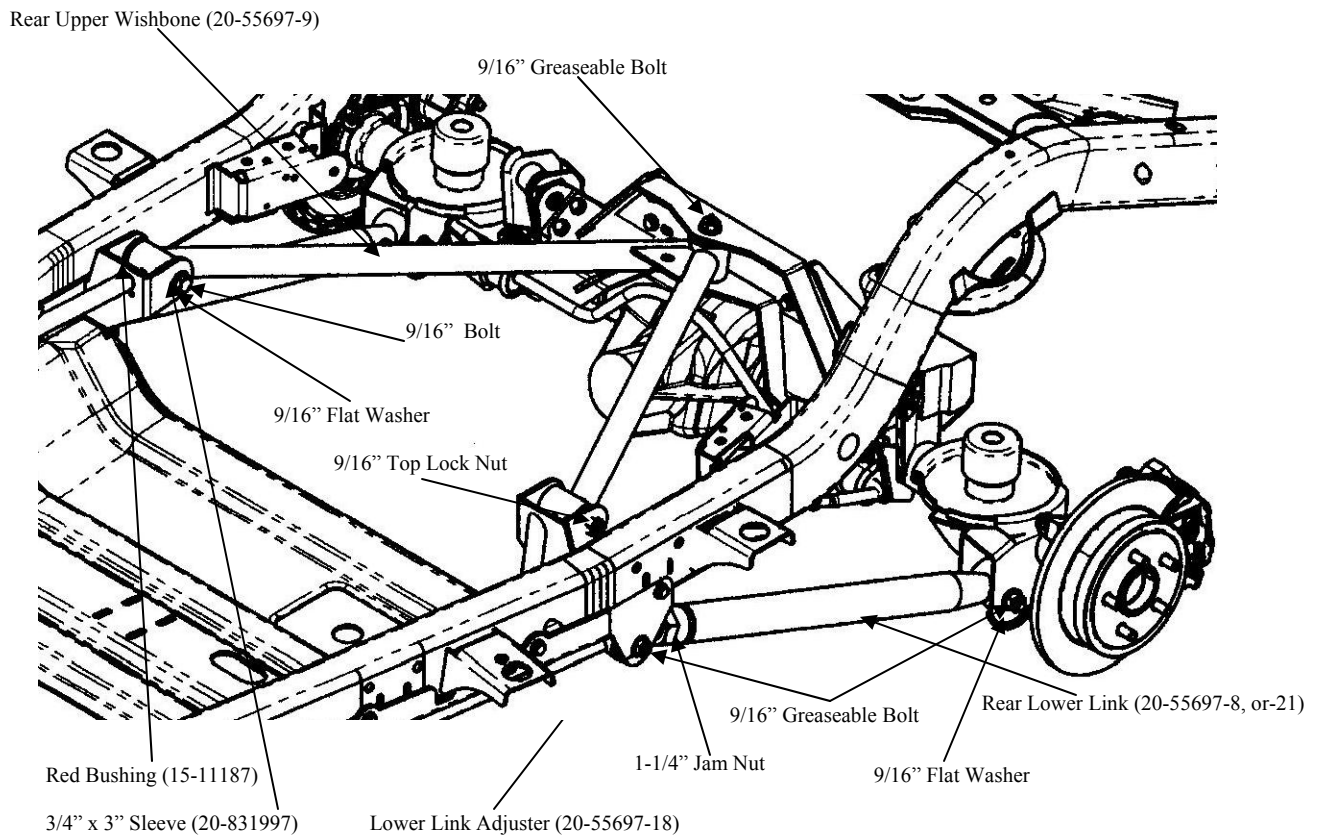

Illustration 35



23. Assemble and install Rear Sway Bar Links. (**Illustration 37**)

24. Install new Rear Shocks (50-BE5-C017-T0). (**Illustration 38**)

25. **If necessary, install Slip Yoke Eliminator at this time.**

26. Install the wheels and tires, and lower the vehicle to the ground. Torque lug nuts to 80 lb/ft.

Illustration 36

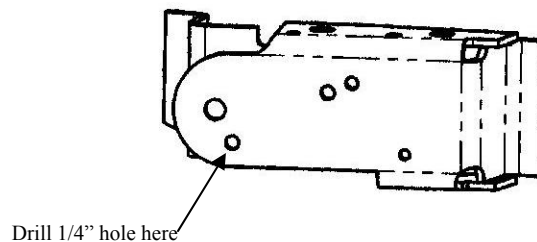

Illustration 37

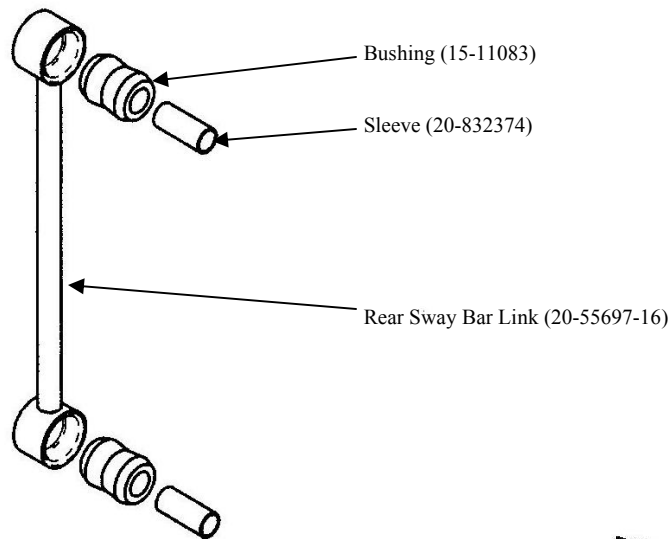
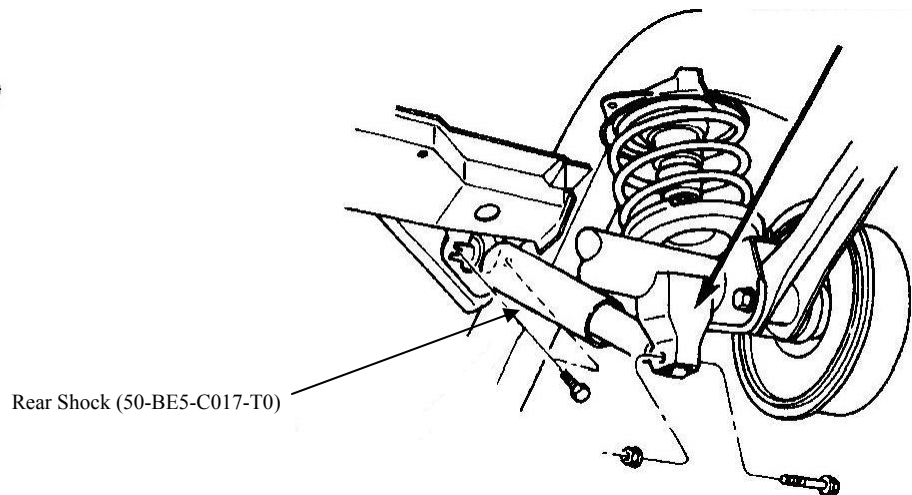

Illustration 38



Some Final Notes

1. After installation is complete, double check that all nuts and bolts are tight. Refer to the torque specifications chart on the last page.
2. If new tires are installed that are more than 10% taller than original tires, the speedometer must be recalibrated. Contact an Authorized Jeep dealer for details on recalibration.
3. With vehicle on the floor, cycle the steering lock to lock and inspect steering, suspension and driveline systems for proper operation, tightness and adequate clearance. Recheck brake/hose fitting for leaks. Be sure all hoses are long enough.
4. Have headlights readjusted to proper setting.
5. Realign front end to factory specifications. Be sure vehicle is at desired ride height prior to realignment.

Torque Specifications

General Torque Specifications:

5/16"	20 ft. lbs.	M6	9 ft. lbs.
3/8"	35 ft. lbs.	M8	23 ft. lbs.
7/16"	60 ft. lbs.	M10	45 ft. lbs.
1/2"	90 ft. lbs.	M12	75 ft. lbs.
9/16"	160 ft. lbs.	M14	120 ft. lbs.
5/8"	175 ft. lbs.	M16	165 ft. lbs.
3/4"	250 ft. lbs.	M18	220 ft. lbs.

Existing Hardware Torque Specifications:

Hub to Knuckle Bolts	75 ft. lbs.
Front Axle Nut	175 ft. lbs.
Front Track Bar to Axle Bolt & Nut	55 ft. lbs.
Front Track Bar to Frame Nut	65 ft. lbs.
Sway Bar Link to Axle Bolts & Nuts	70 ft. lbs.
Lower Ball Stud Nut	80 ft. lbs.
Upper Ball Stud Nut	75 ft. lbs.
Tie Rod Nuts	35 ft. lbs.
Caliper Mount to Steering Knuckle Bolts	11 ft. lbs.
Front Brakeline Banjo Bolts	23 ft. lbs.
Rear Stabilizer Bar Bolts	40 ft. lbs.
Front Shock, Lower Mount Bolts	20 ft. lbs.
Wheel Lug Nuts	110 ft. lbs.
Transmission Mount Nuts	26 ft. lbs.
Rear Shock, Upper Bolts	23 ft. lbs.
Rear Shock, Lower Nut	74 ft. lbs.