



7/10/13

**1984-2001 JEEP CHEROKEE
4" SUSPENSION SYSTEM
P/N: 10-45484**

INSTALLATION INSTRUCTIONS

NOTE: Each lift kit, and options to lift kits, are packaged separately. Therefore installation procedures are covered in separate instructions. Familiarize yourself with each specific set of instructions before beginning.

PART LIST

ITEM	DESCRIPTION	QTY.	ILLUS.
Box 1 of 4			
20-55497-1	Lower Control Arm	2	3, 4
20-55484-2	Upper Control Arm	2	4
20-55697-5	Front Track Bar	1	6
20-834285	Rod End, Track Bar (With Nut and Cotter Pin)	1	6
20-70112	Hardware Pack, Front Sway Bar Link		
13-21482-Z	Bolt, 3/8" x 2-1/2" Gr. 8	2	8
13-23471-Z	Bolt, 3/8" x 1-1/2" Gr. 8	2	8
13-30408-Z	Flat Washer, 3/8" HRDN	8	8
13-10553-Z	TopLoc Nut, 3/8"	4	8
20-55397-1	Front Sway Bar Link	2	8
20-55397-3	Front Sway Bar Mount Bracket	2	8
20-831451	Sleeve, 5/8" OD x 12mm ID x 1.48"	2	8
20-831399	Sleeve, 5/8" OD x .120 ID x 1.48"	2	8
15-11083	Bushing, Hour Glass	4	8
20-71539	Hardware Pack, Front Bumpstop Pads		
20-55497-2	Bumpstop Pad	2	5
13-22145-Z	3/8" x 2" Bolt, Self Tapping	2	5
20-72176	Hardware Pack, Lower Control Arms		
15-11252	Bushing, Lower Arm	4	3
20-830996	Sleeve, 3/4" x 2-5/8"	2	3
20-72189	Hardware Pack, Upper Control Arms		
13-22899-Z	10MM x 90MM Bolt	2	4
13-30642-Z	10MM Flat Washer	4	4
13-10839-Z	10MM Top Lock Nut	2	4
20-70980	Hardware Pack, Front Brakeline		
13-22717-Z	5/16" x 3/4" Self Tapping Bolt	2	
20-68305	Hardware Pack (Universal)		
13-20447-Z	Unslot Hex, #10 x 1/2"	4	
15-10966	Clamp, 3/8" x 3/8" x .203"	4	
15-11395	Wire Tie, 6"	4	
15-11447	Wire Tie, 8"	2	
15-11460	Wire Tie, 11"	2	
15-12188	Rear Extended Bumpstop	2	13

PART LIST

ITEM	DESCRIPTION	QTY.	ILLUS.
20-72072	Hardware Pack, Rear Brake Line Bracket		
20-55484-4	Cherokee Rear Brake Line Bracket	1	12
13-21157-Z	5/16" x 3/4" Bolt	1	12
13-30187-Z	5/16" Flat Washer	2	12
13-10155-Z	5/16" Nyloc Nut	1	12
Box 2 of 4			
20-20361-1	Front Coil Spring	2	7
Box 3 of 4			
20-55484-3	Rear Shackle	2	10
20-72007	Hardware Pack, Shackle Bushings		
15-12162	Shackle Bushing	4	10
20-835527	3/4" x 2-13/16" Sleeve	2	10
13-70182	Cherokee Rear Add-A-Leaf	2	11
20-72202	Hardware Pack, Center Bolts		
13-91517	5/16" x 3" Center Bolt with Nut	2	11
Box 4 of 4			
24-188197	Front Shock	2	7
33-066868	Rear Shock	2	

INTRODUCTION

Installation by a professional mechanic is recommended. Use of the appropriate tools, a Jeep service manual, and a shop hoist can greatly reduce installation time.

Prior to installation, carefully inspect the vehicle's steering and drive train systems, paying close attention to the tie-rod ends, pitman arm, ball joints and wheel bearing preload. Also check steering-to-frame and suspension-to-frame attachment points for stress cracks. The overall vehicle must be in excellent working condition; repair or replace worn parts.

Read instructions carefully and study illustrations before attempting installation. **RCD Suspension** is not responsible for damage, failure or injury resulting from improper installation or parts substitution of this kit.

Check parts and hardware against the parts list to assure that your kit is complete. Report any shortages to RCD Suspension at (1-619-588-4723). The parts and hardware supplied are of high-grade material and must not be replaced by inferior parts or failure may result. Do not begin installation if parts are missing.

Separate parts according to the areas where they will be used. Placing the hardware with brackets before you begin will save installation time.

This kit is supplied as a bolt-on assembly. Do not weld anything to the components and do not weld the components to the vehicle.

All components in this kit come with a protective coating. Do not plate (i.e. chrome, cadmium, zinc etc.) or otherwise alter the finish in any way. This could decrease the structural strength of the components.

Secure and properly block vehicle prior to beginning installation.

Always wear safety glasses when using power tools.

Foot-Pound torque readings are listed on the Torque Specifications chart at the end of the instructions unless specifically stated in an instruction. **DO NOT USE AN IMPACT WRENCH TO TIGHTEN ANY OF THE BOLTS.**

PLEASE NOTE

WARNING: DO NOT USE WHEEL SPACERS

Front-end realignment is necessary.

Speedometer recalibration is necessary if larger tires (10% more than stock diameter) are installed.

System is designed to accommodate up to a 31" x 10.50" tire on a wheel size of 15" x 8" with a maximum of 4.5" backspacing.

Special tools are required for safe removal and installation of the ball joints, tie-rods and torsion bars. These tools can be purchased from your Jeep Dealer.

Tool (Puller P/N C-3894-A)

Front Installation Instructions

1. Raise and support vehicle with jackstands on frame located behind front lower control arms and in front of rear spring perch. Support axle with a floorjack. Remove wheels and tires.
2. Place reference marks on the front drive shaft and axle. Disconnect the front drive shaft from axle. **(Illustration 1)**
3. Remove front shock absorbers. Disconnect and remove stabilizer links.
4. Disconnect Trac Bar at both ends and remove from vehicle.
5. Disconnect Drag Link from Pitman Arm. **(Illustration 2)**
6. Locate and remove the two bolts attaching each Brake Caliper to the Steering Knuckles. Remove the Calipers and hang out of the way with a length of wire, careful not to damage the brake hose. **DO NOT let the caliper hang by the brake hose.**
7. Lower axle until coil spring is free from upper mount. Remove coil spring retainer bolt and remove the coil spring.
8. Install bushings (15-11252) supplied into end of two new Lower Links Supplied. (20-55497-1) Press Sleeve (20-830996) thru center of bushings installed in links. **(Illustration 3)**

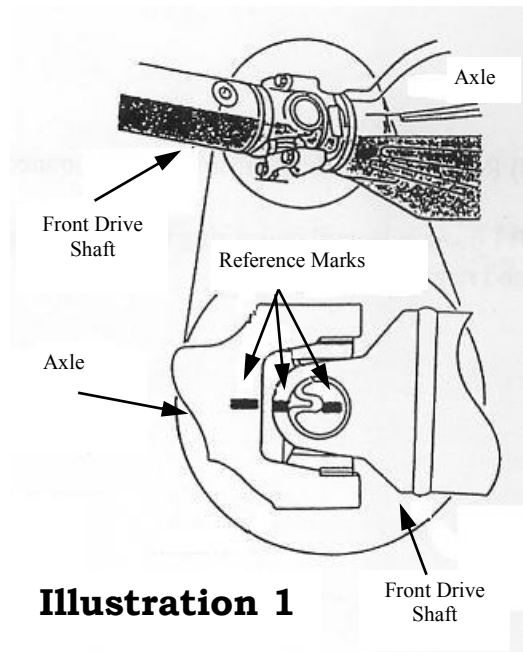

Illustration 1

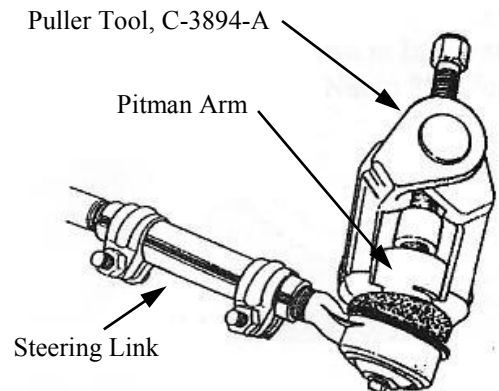

Illustration 2

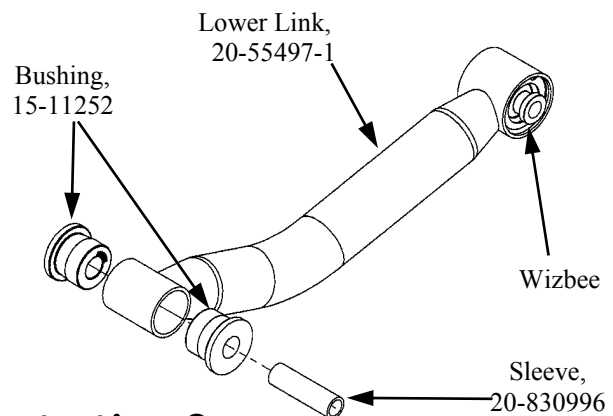

Illustration 3

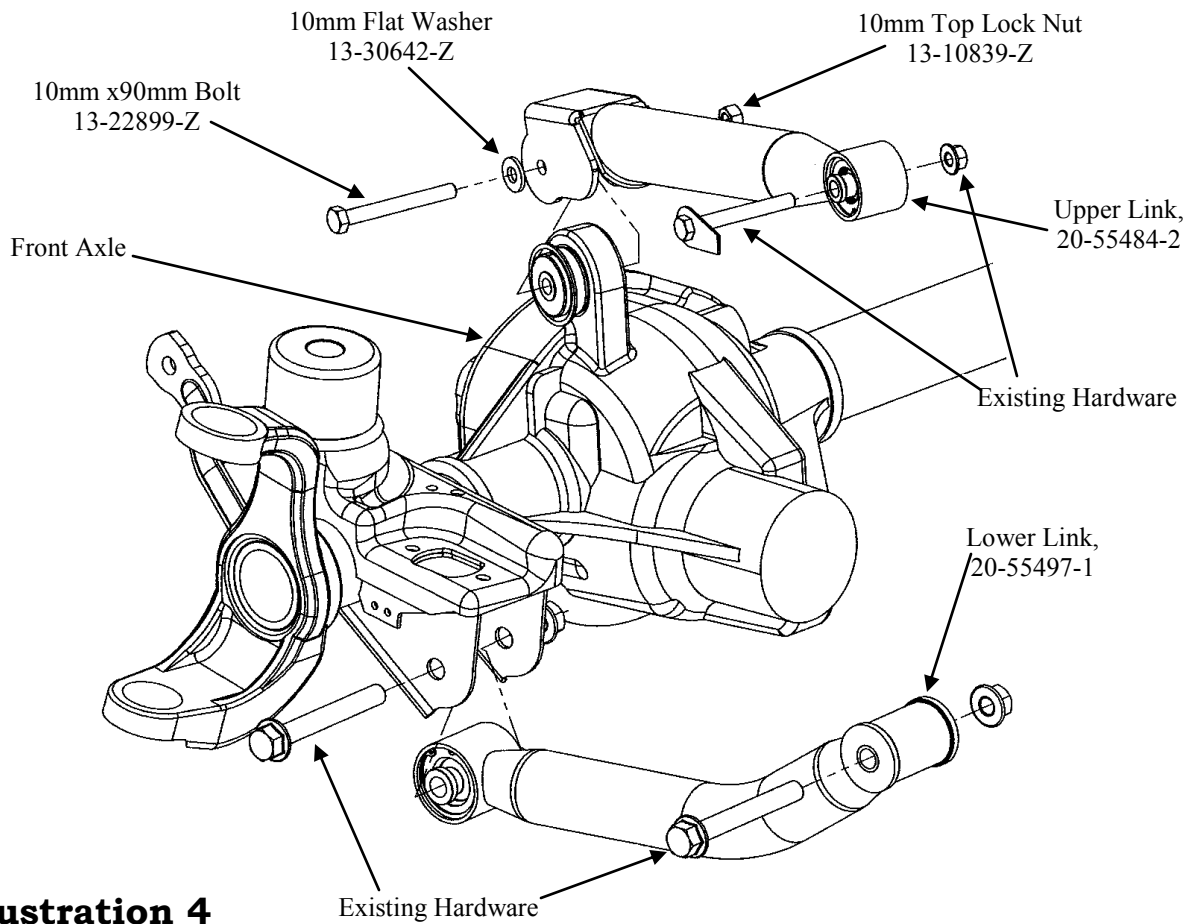

Illustration 4

9. Remove Lower Links and replace with RCD Lower Links (20-55497-1) using existing hardware. **(Illustration 4)** Do not tighten bolts at this time.
10. Remove Upper Links and replace with RCD Upper Links (20-55484-2) using supplied 10mm hardware at front and existing hardware at back. **(Illustration 4)** Do not tighten bolts at this time.
11. Install new Bumpstop Pad (20-55497-2) as shown in **(Illustration 5)**. Mark center of lower coil spring pad. Using an 11/32" diameter drill bit, drill a pilot hole in the previously marked area. Install using 3/8" self-tapping hardware provided. Torque to 30 ft. lbs.

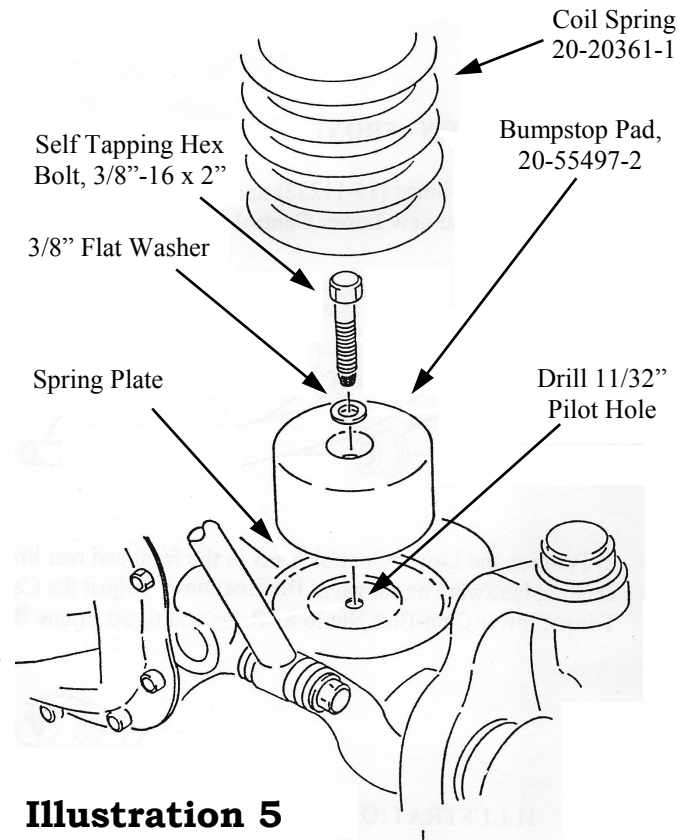
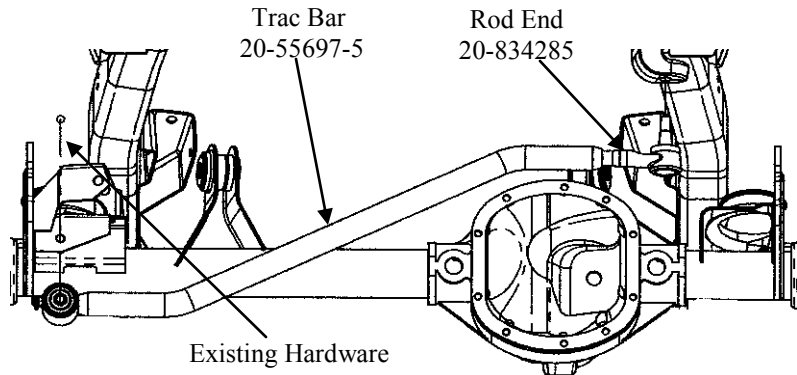

Illustration 5

12. Thread Rod End (20-834285) with Jam Nut into Trac Bar (20-55697-5) until there are no threads showing.

13. Install Trac Bar on Vehicle using existing hardware at axle and new nut and cotter pin at frame. **(Illustration 6)**



14. Position new front coil spring (20-20361-1) on axle pad. Re-install coil spring retainer and bolt. Torque to 16 ft. lbs.

Illustration 6

15. Raise axle into position making sure BOTH coil springs seat in upper mounts, then raise axle another 2". Install new longer shock absorbers (24-188197) as shown in **(Illustration 7)**. Tighten upper shock nut until snug and rubber is properly compressed. Torque lower shock bolts to 20 ft. lbs.

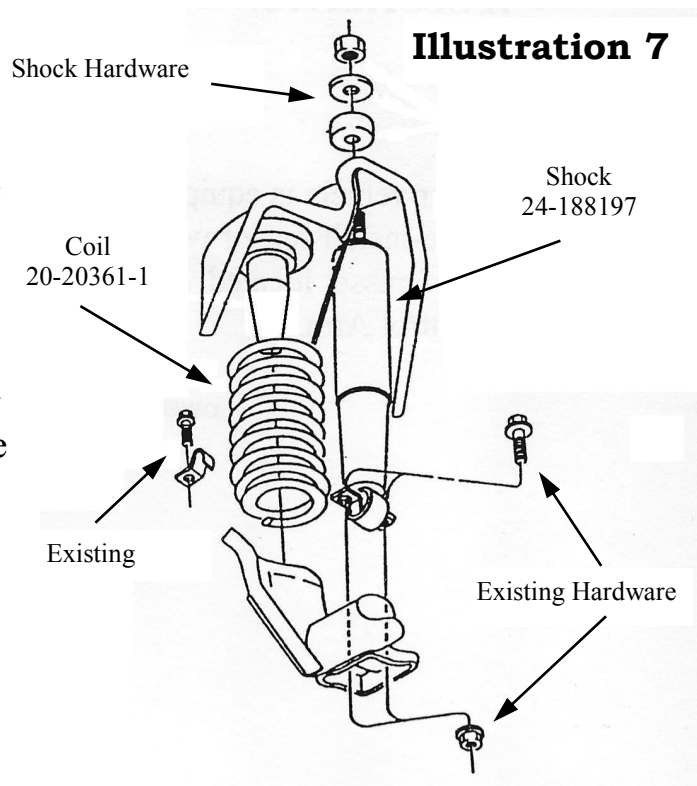

Illustration 7

16. Re-attach Drag Link to Pitman Arm. Torque nut to 55 ft. lbs. Install new cotter pin.

17. Press Hour Glass Bushings (15-11083) into Sway Bar Links (20-55397-1). Press Sleeve 20-831399 (5/8"OD x 3/8"ID x 1.48") in top bushing and Sleeve 20-831451 (5/8"OD x 12mm ID x 1.48") into lower bushing.

18. Mount Sway Bar Mount Bracket (20-55397-3) to sway bar using 3/8" x 1-1/2" Bolt and hardware provided. Attach Front Sway Bar Link (20-55397-1) using provided hardware as shown in **(Illustration 8)**. Torque nuts to 30 ft/lbs.

19. Re-attach Brake Calipers to Front Knuckles. Torque bolts to 11 ft. lbs.

20. Locate bracket where brake hose attaches to inner frame. Remove bolt and pull bracket down 1-1/2". Mark and drill a 17/64" hole in frame. Use the 5/16" self tapping screws (13-22717-Z) provided, to secure the bracket to the frame.

21. Cycle steering lock to lock and inspect steering, suspension and driveline systems for proper operation, tightness and adequate clearance. Recheck brake hose/fittings for leaks. Be sure all hoses are long enough and do not rub suspension components or tire.

Illustration 8

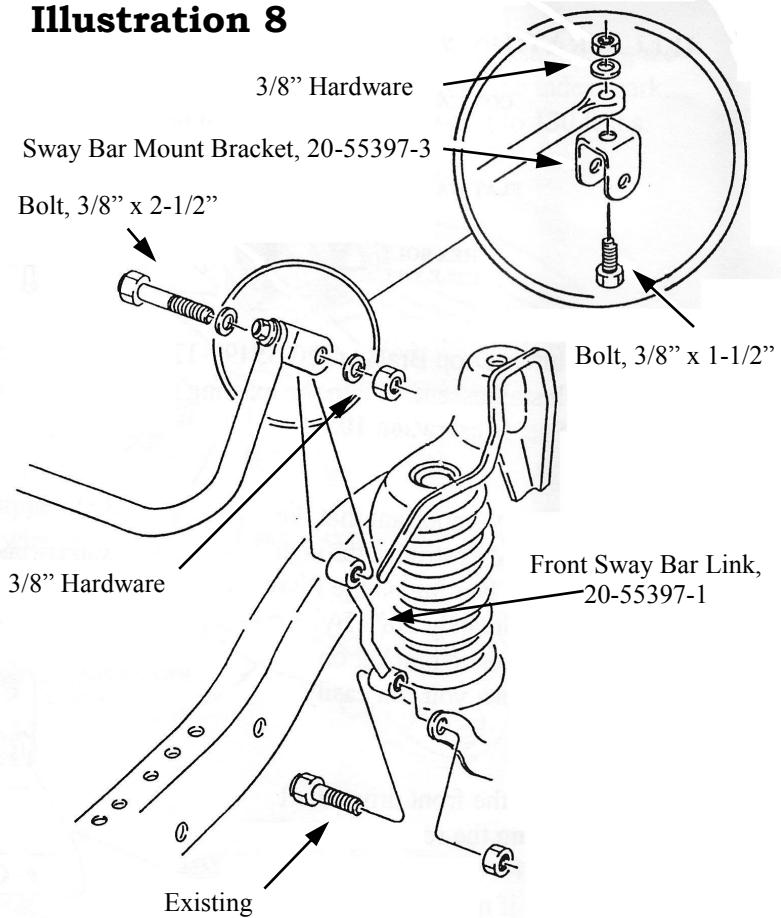

Rear Installation Instructions

1. Make sure frame is still securely supported by jack-stands on frame right in front of rear leaf spring mounts. Support rear axle with jack and remove rear tires.

2. Remove rear shock absorbers.

3. Locate place where rear brake line attaches to chassis. Remove clip retaining brake line and pull line free from bracket.

4. Lower rear axle until there is no tension on rear leaf springs.

5. Remove upper and lower shackle bolts and remove shackles. (**Illustration 9**)

6. Insert Bushings (15-12162) and Sleeves (20-835527) into new Shackles (20-55484-3) and install using original hardware. (**Illustration 10**) Torque bolts to 130 ft. lbs.

7. Remove U-bolts attaching rear axle to driver side leaf spring. Carefully lower rear axle.

Illustration 9

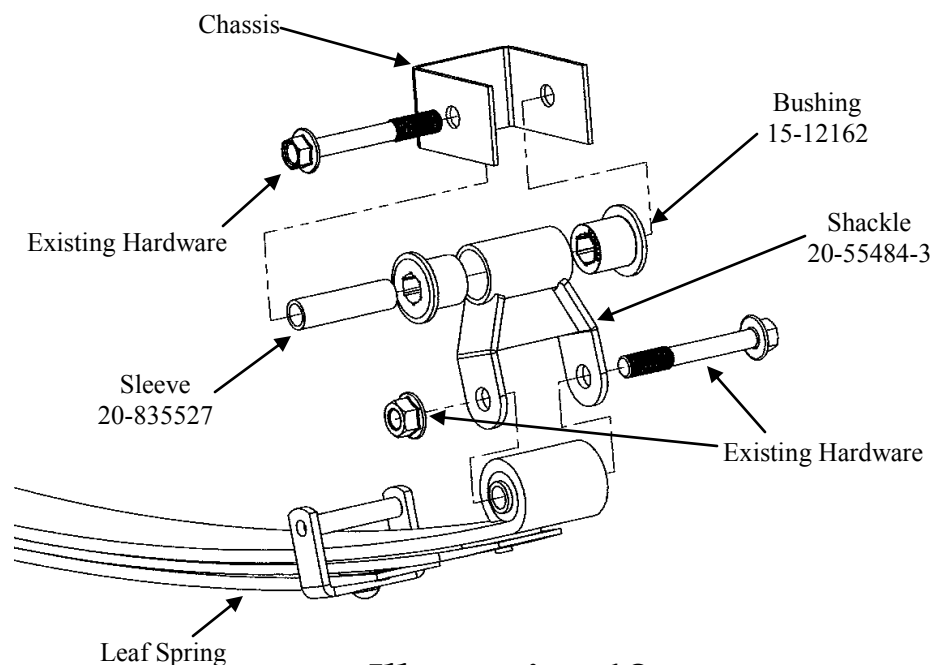
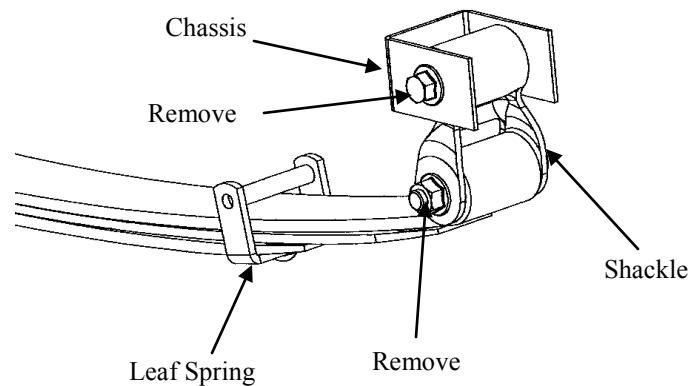

Illustration 10

CAUTION: Do not allow axle to hang by any hoses or cables.

8. Hold the spring assembly securely together with C-Clamps. Remove any spring leaf alignment clamps. Remove the spring center bolt. If necessary, use a hammer and punch to drive it out.

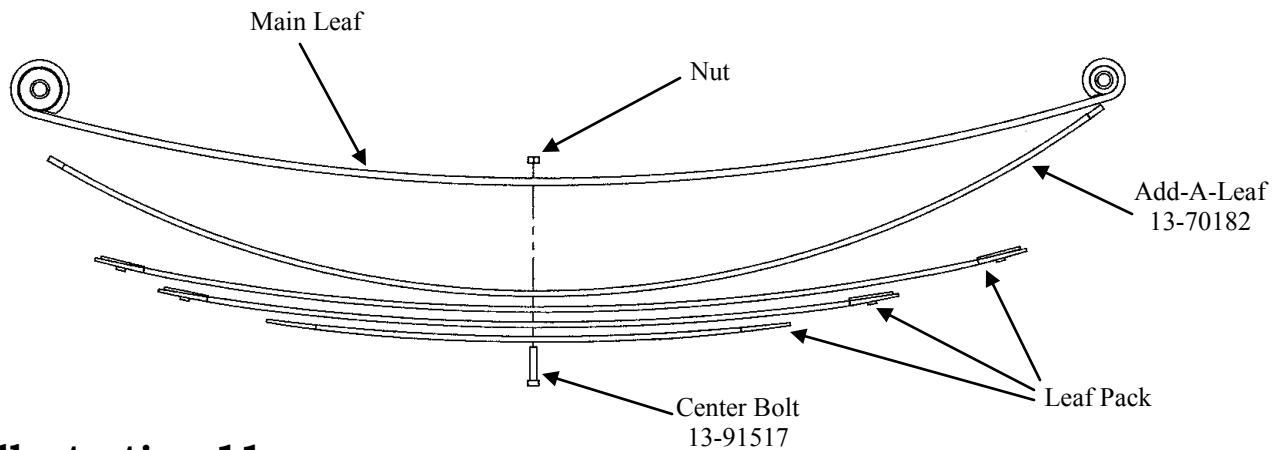

Illustration 11

9. Apply a small amount of grease to the end of the Add-a-Leaf. Place leaf in the spring assembly as shown (**Illustration 11**) and reassemble the leaf spring using C-Clamps.

10. Insert the new Center Bolt (13-91517). Torque to 20 ft. lbs.

CAUTION: Do not try to compress the spring with the center bolt.

11. Re-mount axle to spring using existing U-Bolts and Nuts. Torque nuts to 100 ft. lbs.

12. **Repeat steps 7 thru 11 on opposite side.**

13. Install new longer Shock Absorbers (33-066868). Tighten upper bolts to 20 ft. lbs. Tighten lower nut until bushing is compressed.

14. Install Brake Line Drop Bracket (20-55484-4) to original bracket as shown **(Illustration 12)**

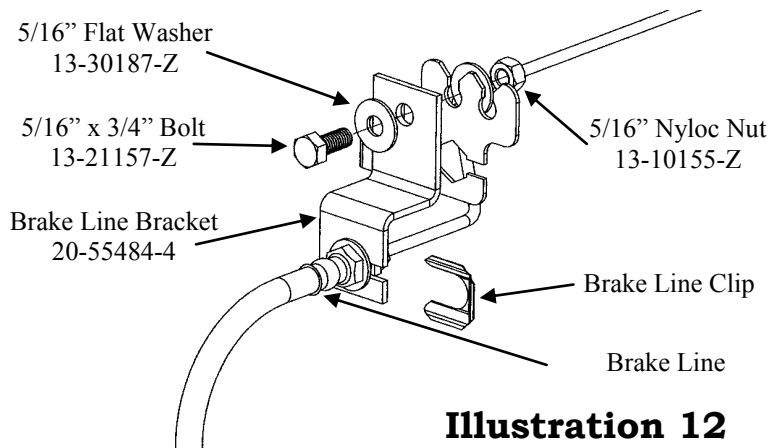
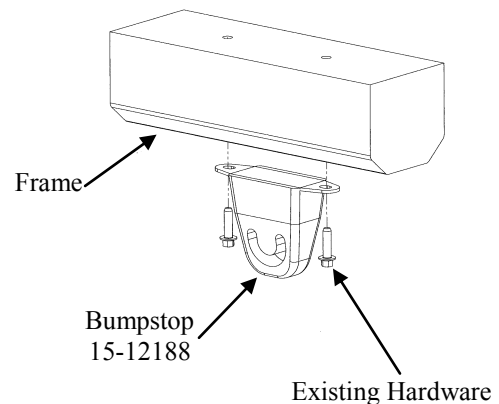

Illustration 12

15. Install Extended Rear Bumpstops to frame using existing hardware. **(Illustration 13)** Torque bolts to 20 ft. lbs.

Illustration 13

16. Cycle and inspect suspension and driveline systems for proper operation, tightness and adequate clearance. Recheck brake hose/ fittings for leaks. Be sure all hoses are long enough and do not rub suspension components or tire.



17. Install the wheels and tires. Remove the jackstands and lower the vehicle.

18. Once vehicle is on ground, at ride height torque front upper control bolts to 55 ft. lbs. Torque lower control arm bolts to 130 ft. lbs. Torque rear leaf spring-to-body, rear leaf spring-to-shackle and shackle-to-body bolts to 100 ft. lbs.

Torque Specifications

General Torque Specifications:

5/16"	20 ft. lbs.	M6	9 ft. lbs.
3/8"	35 ft. lbs.	M8	23 ft. lbs.
7/16"	60 ft. lbs.	M10	45 ft. lbs.
1/2"	90 ft. lbs.	M12	75 ft. lbs.
9/16"	160 ft. lbs.	M14	120 ft. lbs.
5/8"	175 ft. lbs.	M16	165 ft. lbs.
3/4"	250 ft. lbs.	M18	220 ft. lbs.

Existing Hardware Torque Specifications:

Brake Caliper Mounting Bolt	11 ft. lbs.
Universal Joint Strap Bolt	14 ft. lbs.
Drag Link to Pitman Arm Stud Nut	35 ft. lbs.
Antiroll Bar Link to Axle Bracket Nut	70 ft. lbs.
Lower Control Arm Nut, to Axle	130 ft. lbs.
Lower Control Arm Nut, to Frame	130 ft. lbs.
Upper Control Arm Nut, at Axle	55 ft. lbs.
Upper Control Arm Nut, at Frame	55 ft. lbs.
Front Shock Absorber Lower Bolt	20 ft. lbs.
Track Bar to Axle Bracket Bolt/Nut	74 ft. lbs.
Track Bar to Frame Bracket Stud Nut	60 ft. lbs.
Leaf Spring Shackle to Body Bolt	65 ft. lbs.
Leaf Spring Shackle Bolt/Nut	95 ft. lbs.
Rear Shock Absorber Lower Stud Nut	44.0 ft. lbs.
Leaf Spring U-Bolt Nut	100 ft. lbs.