



SUSPENSION SYSTEMS

3/8/02

*'99-'02 FORD F250/F350
4WD P/U AND EXCURSION
STAINLESS STEEL MULTIPLE SHOCK SYSTEM
(Bilstein 7100 Series Remote Reservoir Shocks included)*

P/N 10-32600

INSTALLATION INSTRUCTIONS

Intended as an option once RCD Lift Kit is installed

NOTE: Each Lift Kit, and options to Lift Kits, are packaged separately. Therefore installation procedures are covered in separate instructions. Familiarize yourself with each set of instructions before beginning.

Parts List

<u>Item</u>	<u>Description</u>	<u>Qty</u>	<u>Illus.</u>
<u>Box 1 of 1</u>			
20-32300-1	Mount, Center Dual Shock-Engraved	2	1
20-32300-2	Front Brace-Dual Shock, Passenger	1	1
20-32300-3	Front Brace-Dual Shock, Driver	1	1
20-32300-4	Rear Brace-Dual Shock, Passenger	1	1
20-32300-5	Rear Brace-Dual Shock, Driver	1	1
20-68851	Hardware Pack Containing: (Dual Shock Mount)		
13-23003-Z	Hex Bolt, 1/2"-13 x 6-1/2" Lg. Gr.8	2	1
13-23081-Z	Hex Bolt, 12mm-1.75 x 150mm Gr. 10.9	2	1
13-21456-Z	Hex Bolt, 1/2"-13 x 1-1/2" Lg. Gr.8	4	1
13-30382-Z	Flat Washer, 1/2" Hrdn.	12	1
13-30546-Z	Flat Washer, 12mm Hrdn.	6	1
13-10514-Z	Top Lock Nut, 1/2"-13 Gr. C	6	1
13-10696-Z	Top Lock Nut, 12mm - 1.75 Gr. 10.9	4	1
11-15846	Spacer, 1-1/4" x .375w x 1.53"	2	1
15-10248	End Cap, 1-1/2"	8	1
15-11525	End Cap, 1-1/2" x .60"	2	1

Box 2 of 2

50-AK7110SB	Shock, 8" Reservoir	4	1
-------------	---------------------	---	---

BEFORE YOU BEGIN

- Installation requires a professional mechanic. Read instructions carefully and study illustrations before attempting installation. *Race Car Dynamics* is not responsible for damage, failure or injury resulting from improper installation or parts substitution of this kit.
- Check parts and hardware against the parts list to assure that your kit is complete. Report shortages to *Race Car Dynamics* at (1-619-588-4723). The parts and hardware supplied are of high-grade material and must not be replaced by inferior parts or failure may result.
- Separate parts according to the areas they will be used. Placing the hardware with brackets before you begin will save installation time.
- This kit is supplied as a bolt-on assembly. Do not weld anything to the components and do not weld the components to the vehicle.
- All components in this kit come with a protective coating. Do not plate (i.e. chrome, cadmium, zinc etc.) or otherwise alter the finish in any way. This could weaken the structural strength of the components.

- ❑ Secure and properly block vehicle prior to beginning installation.
- ❑ Always wear safety glasses when using power tools.
- ❑ Foot-pound torque readings are listed on the Torque Specifications chart at the end of the instructions unless specifically stated in an instruction. **DO NOT USE AN IMPACT WRENCH TO TIGHTEN ANY OF THE BOLTS.**

PLEASE NOTE

- Intended for use with a 4" or 6" Suspension Lift Series.
- Includes (4) Bilstein 7100 Series Remote Reservoir Shock Absorbers.
- Includes all necessary mounting hardware.
- To install rear 7100 series shocks order #AK7114SB (rear mount may need to be modified).

INSTALLATION

1) Raise the vehicle. If working without a shop hoist, put vehicle in gear, set emergency brake and block rear wheels, in front and behind tires. Loosen lug nuts. Lift vehicle with floor jack and place safety jack stands under frame rails, behind front wheel wells, and lower each frame rail onto jack stands. Remove the front tire/wheel assemblies.

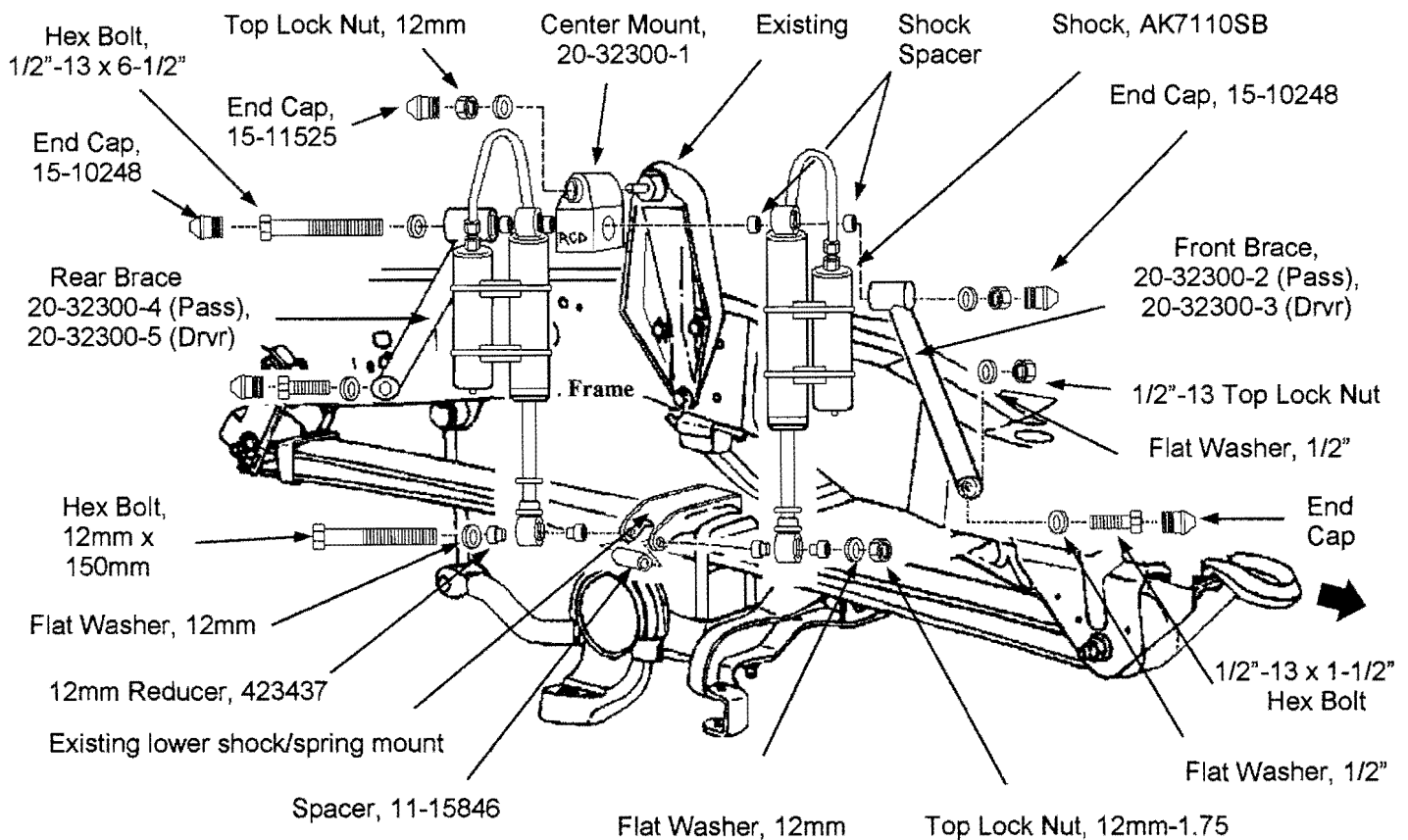

Passenger's Side Shown

Illustration 1

2) Support front axle with a suitable floor jack near the spring seat. Raise the jack just enough to support axle's weight.

3) Remove existing shock.

4) Hold Lower Shock Spacer (11-15846) between tabs on existing lower shock/spring mount To install Shock (AK7110SB), insert 12mm Reducer on each side of Shock eye as shown in **Illustration 1**. Install shock assembly with 12mm x 150mm Hex Bolt and Flat Washer. The Bolt passes through bottom eye of new Shocks and Spacer. Install Flat Washer and 12mm Top Lock Nut. Do not tighten yet.

5) Install Center Mount (20-32300-1) to stud on existing upper shock bracket as shown in **Illustration 1**. Secure with Flat Washer and 12mm Top Lock Nut provided. Do not tighten.

6) Align eye of Shocks with mounting hole in Center Mount. Temporarily install Shocks to Center Mount with 1/2"-13 x 6-1/2" Lg. Gr. 8 Hex Bolt and Flat Washer.

WARNING: Be sure to include Shock Spacers as shown in **Illustration 1**.

7) The Dual Shock Braces are specific to each side of the vehicle, as well as to front and rear, for each side. The shorter braces are the front. The longer Braces are the rear brace. The longest end piece on all the Braces is the top. If installed improperly the bottom end piece will not lay flush to the frame. Identify the Brace (20-32300-3 Drvr. Front), (20-32300-5 Drvr. Rear), (20-32300-2 Pass. Front) (20-32300-4 Pass. Rear) needed and temporarily install appropriate Brace to Center Mount as shown in **Illustration 1**. On the bottom end of Brace center punch mounting hole location to be drilled. Remove Brace and drill 1/2" hole. Repeat procedure with opposite side Brace.

NOTE: The support Brace mounts between frame and brake line.

8) Use the 1/2"-13 x 6-1/2" Hex Bolt, Flat Washers and Nyloc Nut to secure Braces and Shock assembly to Center Mount. Install lower end of Braces to frame using 1/2"-13 x 1-1/2" Hex Bolt, Flat Washers and Nyloc Nut. Torque all 1/2" Brace and Mount nuts to 90 ft. lbs. Install decorative End Caps (15-10248) to Brace ends to cover hardware. Install the shorter decorative End Cap (15-11525) to cover Center Mount hardware.

- 9) Torque lower Shock 1/2" Nut to 75 ft. lbs.
- 10) Use provided Spacers and Clamps to attach reservoir to Shock.
- 11) Install tire/wheel assembly and lower vehicle.
- 12) Repeat preceding steps on opposite side of vehicle.
- 13) Check the torque on all fasteners after the first 100 miles. Periodically inspect components for tightness and for any damage, especially after off-road use.

SOME FINAL NOTES

- After installation is complete, double check that all nuts and bolts are tight. Refer to torque specifications chart on last page.
- If new tires were installed that are more than 10% taller than original tires, the speedometer must be recalibrated. Contact an Authorized Ford dealer for details on recalibration.
- With vehicle on the floor, cycle steering lock to lock and inspect steering, suspension and driveline systems for proper operation, tightness and adequate clearance. Check brake hose fittings for leaks and make sure all hoses are long enough.

TORQUE SPECIFICATIONS *(Grade 8 & Class 10.9)*

5/16" NUTS	20 ft. lbs.	M6	9 ft. lbs.
3/8" NUTS	35 ft. lbs.	M8	23 ft. lbs.
7/16" NUTS	60 ft. lbs.	M10	45 ft. lbs.
1/2" NUTS	90 ft. lbs.	M12	75 ft. lbs.
9/16" NUTS	160 ft. lbs.	M14	120 ft. lbs.
5/8" NUTS	175 ft. lbs.	M16	165 ft. lbs.

EXISTING TORQUE SPECIFICATIONS

Wheel 8-lug M14 Bolts (stock) 148 ft. lbs.