



3/11/14

**'09-'13 FORD F-150 4WD
4"-6" SUSPENSION SYSTEM
P/N: 10-42409**

INSTALLATION INSTRUCTIONS

**ATTENTION!: This kit is designed to work with 20"
and larger wheels only!**

NOTE: Each lift kit, and options to lift kits, are packaged separately. Therefore installation procedures are covered in separate instructions. Familiarize yourself with each specific set of instructions before beginning.

PART LIST

<u>ITEM</u>	<u>DESCRIPTION</u>	<u>QTY.</u>	<u>ILLUS.</u>
Box 1 of 6			
20-52409-1	Front Crossmember	1	10, 12, 13
20-52409-2	Rear Crossmember	1	8, 9, 12, 13
Box 2 of 6			
20-52409-6P	Steering Knuckle - Passenger Side	1	
Box 3 of 6			
20-52409-19	Compression Strut	2	18
20-51099-22	Compression Strut Bracket	4	8, 18
20-52409-20	Doubler Plate	2	18
20-68175	Hardware Pack (Bushings & Sleeves)		
15-11148	Bushing, Red	8	18
20-830918	3/4" OD x .095w x 2-3/4" Sleeve	4	18
20-72553	Hardware Pack (Compression Strut)		
13-20069-Z	Hex Bolt, 1/2"-13 x 4"	4	18
13-21014-Z	Hex Bolt, 1/2"-13 x 3"	2	18
13-20497-Z	Hex Bolt, 1/2"-13 x 1"	2	8, 18
13-30034-Z	Flat Washer, 1/2"	14	8, 18
13-30028-Z	Lock Washer, 1/2"	2	8
13-10038-Z	Nyloc Nut, 1/2"-13	6	18
Box 4 of 6			
20-52409-7	Skid Plate	1	13
20-52409-9	Driver Sway Bar Bracket	1	9, 17
20-52409-10	Passenger Sway Bar Bracket	1	9, 17
20-52409-3	Driver Diff Bracket	1	7
20-52409-4	Passenger Diff Bracket	1	7
20-72280	Hardware Pack (Crossmember)		
20-52409-17	Front Cam Bolt 160MM	2	12
20-52409-18	Rear Cam Bolt 150MM	2	12
13-23796-Z	Hex Bolt, 18MM-2.5 x 150MM	2	9
13-30876-Z	Flat Washer, 18MM	8	9, 12
13-10969-Z	Nyloc Nut, 18MM-2.5	6	9, 12
20-72293	Hardware Pack (Diff Drop Bracket)		
13-23107-Z	Hex Bolt, 9/16"-12 x 4"	3	7, 9
13-30395-Z	Flat Washer, 9/16"	6	7, 9
13-10397-Z	Top Lock Nut, 9/16"-12	3	7, 9

20-72306	Hardware Pack (Skid Plate & Sway Bar)		
13-22938-Z	Hex Bolt, 3/8"-16 x 1-1/4"	8	13, 17
13-30408-Z	Flat Washer, 3/8"	14	13, 17
13-30151-Z	Lock Washer, 3/8"	2	13
13-10553-Z	Top Lock Nut, 3/8"-16	6	13, 17
20-72319	Hardware Pack (Front Brake Line)		
20-52409-13	Front Brake Line Bracket	2	16
13-20536-Z	Hex Bolt, 5/16"-18 x 1"	2	16
13-30187-Z	Flat Washer, 5/16"	4	16
13-10155-Z	Nyloc Nut, 5/16"-18	2	16
20-72332	Hardware Pack (Front Driveshaft Spacer)		
20-52409-8	Front Driveshaft Spacer	1	11
13-24238	Socket Head Bolt, 10MM-1.5 x 80MM	6	11
20-834220	Rear Block, 5"	2	20
13-91049	U-Bolt, 9/16" x 3-1/4" x 12.5" SQ	4	20
20-68188	Hardware Pack (U-Bolts)		
13-30330	Flat Washer, 9/16" Plain	8	20
13-10423	High Nut, 9/16" Plain	8	20
20-67174	Hardware Pack (Vent Hose)		
20-832335-1	Vent Hose Connector	1	
20-832335-2	Vent Hose 3-1/2"	1	
20-72345	Hardware Pack (Rear Brake)		
20-52409-14	E-Brake Bracket	1	19
20-52409-15	Rear Brake Line Bracket	1	
13-20536-Z	Hex Bolt, 5/16"-18 x 1"	3	19
13-30187-Z	Flat Washer, 5/16"	6	19
13-10155-Z	Nyloc Nut, 5/16"-18	3	19
13-20031-Z	Hex Bolt, 1/2"-13 x 1-1/4"	1	19
13-30034-Z	Flat Washer, 1/2"	2	19
13-10038-Z	Nyloc Nut, 1/2"-13	1	19
20-72358	Hardware Pack (Rear Driveshaft Spacer)		
20-52409-16	Rear Driveshaft Spacer	1	21
13-24251-Z	Hex Bolt, 10MM-1.5 x 55MM	4	21
13-30642-Z	Flat Washer, 10MM	4	21

Box 5 of 6

20-52409-5D	Steering Knuckle - Driver Side	1	
-------------	--------------------------------	---	--

Box 6 of 6

59-72409-1		2	14
59-72409-2		2	

INTRODUCTION

Installation by a professional mechanic is recommended. Use of the appropriate tools, a Ford service manual, and a shop hoist can greatly reduce installation time.

Prior to installation, carefully inspect the vehicle's steering and drive train systems, paying close attention to the tie-rod ends, rack & pinion unit, ball joints and wheel bearing preload. Also check steering-to-frame and suspension-to-frame attachment points for stress cracks. The overall vehicle must be in excellent working condition; repair or replace worn parts.

Read instructions carefully and study illustrations before attempting installation. **RCD Suspension** is not responsible for damage, failure or injury resulting from improper installation or parts substitution of this kit.

Check parts and hardware against the parts list to assure that your kit is complete. Report any shortages to RCD Suspension at (1-619-588-4723). The parts and hardware supplied are of high-grade material and must not be replaced by inferior parts or failure may result. Do not begin installation if parts are missing.

Separate parts according to the areas they will be used. Placing the hardware with brackets before you begin will save installation time.

This kit is supplied as a bolt-on assembly. Do not weld anything to the components and do not weld the components to the vehicle.

All components in this kit come with a protective coating. Do not plate (i.e. chrome, cadmium, zinc etc.) or otherwise alter the finish in any way. This could decrease the structural strength of the components.

Secure and properly block vehicle prior to beginning installation.

Always wear safety glasses when using power tools.

Foot-Pound torque readings are listed on the Torque Specifications chart at the end of the instructions unless specifically stated in an instruction. **DO NOT USE AN IMPACT WRENCH TO TIGHTEN ANY OF THE BOLTS.**

PLEASE NOTE

ATTENTION!: This kit is designed to work with 20” and larger wheels only!

WARNING: DO NOT USE WHEEL SPACERS

Front-end realignment is necessary.

Speedometer recalibration is necessary if larger tires (10% more than stock diameter) are installed.

System is designed to accommodate up to a 35” x 12.50” tire on a wheel size of 20” x 9” with a maximum of 5” backspacing.

Special tools are required for safe removal and installation of the ball joints, tie-rods and torsion bars. These tools can be purchased from your Ford Dealer.

C-Frame and Screw (P/N 211-023)
Front Wheel Hub Remover (P/N 205-D070)

Front Installation Instructions

1. Raise vehicle. If working without a shop hoist, support vehicle with suitable safety jack stands. Put vehicle in gear, set emergency brake and block rear wheels, both in front and behind tires. Loosen front wheel lug nuts. Place floor jack under lower control arm's front crossmember and raise vehicle. Place safety jack stands under frame rails, behind front wheel wells, and lower the frame onto the stands. Once securely on jack stands, remove floor jack. Remove front wheels.
2. If equipped with electric steering, remove skid plate.
3. Beginning with Driver side, unclip brake line, ABS sensor line (if equipped) and 4wd hub vacuum line from each other as well as from any connections on Steering Knuckle. Disconnect the vacuum lines from Integrated Wheel End Disconnect (4wd hub engaging mechanism) at the Steering Knuckle.
4. Remove the two bolts holding the Caliper Anchor Bracket to the Steering Knuckle (**Illustration 1**). Pull Bracket and Caliper assembly away from Brake Rotor and hang out of way with a length of wire, careful not to damage brake lines.
DO NOT let Caliper hang from brake line.

5. Remove Brake Rotor from Hub and Dust Shield from Steering Knuckle.
6. Remove Wheel Speed Sensor from Steering Knuckle.
7. Remove the Axle-to-Wheel Hub Nut dust cover, and then remove Axle-to-Wheel Hub Nut (**Illustration 1**).
8. Remove nut from steering Tie Rod. Separate Tie Rod from Steering Knuckle using special tool 211-023. **NOTE: If vehicle is equipped with an electronic steering rack, be extremely careful, as a shock to the rack can cause internal damage.**

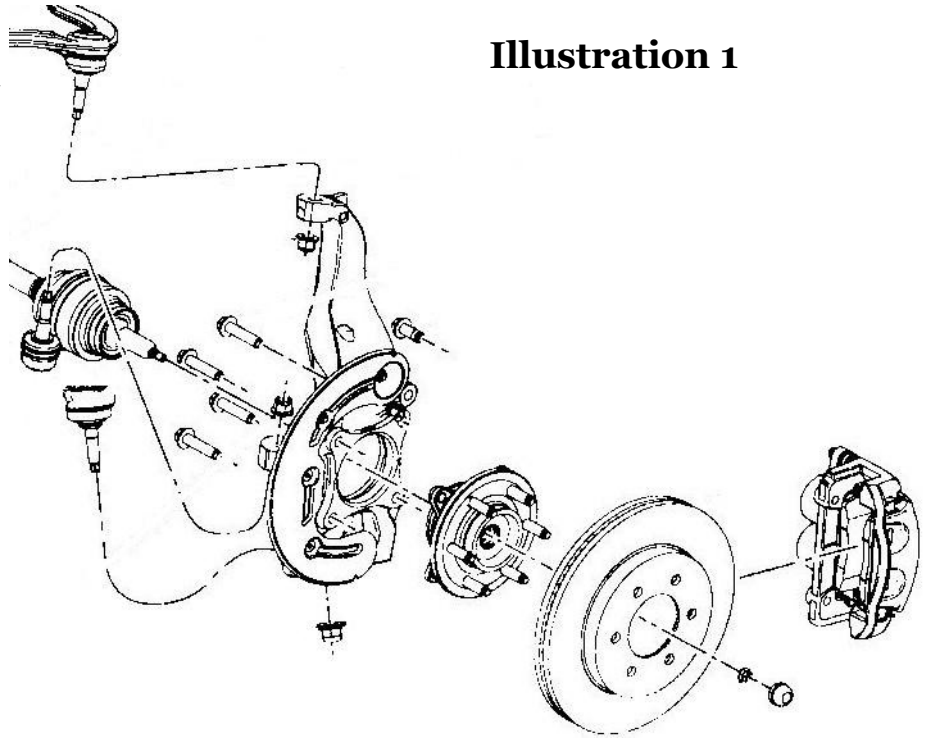

Illustration 1

9. Remove nut from Lower Ball Joint. Separate Lower Ball Joint from Steering Knuckle.
10. Remove nut from Upper Ball Joint. Separate Upper Ball Joint from Steering Knuckle and set Knuckle aside.

11. Remove Sway Bar Link from Lower Control Arm and remove nuts attaching Sway Bar to Chassis and remove Sway Bar (**Illustration 2**).
12. Remove Lower Strut Mount Bolt on Lower Control Arm, followed by the three upper Strut Mount nuts, and remove Strut assembly (**Illustration 3**).
13. Remove the two bolts attaching Lower Control Arm to frame and remove Control Arm from vehicle (**Illustration 3**).

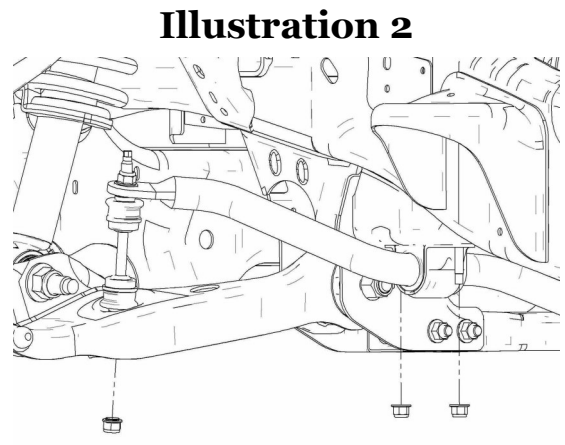

Illustration 2

14. Repeat steps 3-13 on the Passenger Side of the vehicle.
15. Remove the four bolts holding the stock Rear Crossmember onto the frame (just behind the front differential) (**Illustration 4**).

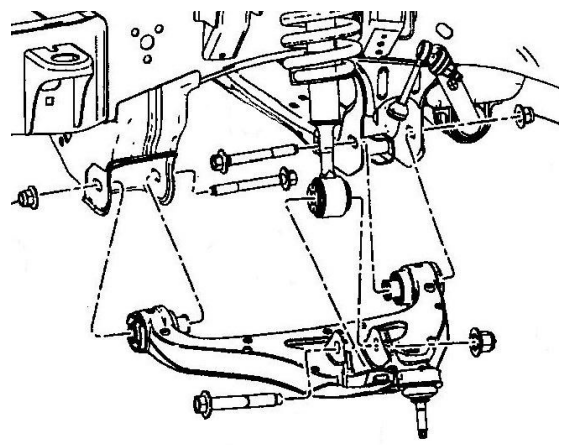

Illustration 3

16. Put an index mark on flange of Front Driveshaft at Differential and remove the six bolts holding the Front Driveshaft to Differential (**Illustration 4**).
17. Support Front Axle Housing with a suitable hydraulic jack. Disconnect axle vent hose from front axle. Remove the three bolts attaching Front Differential. Then lower Front Differential and move out of way.

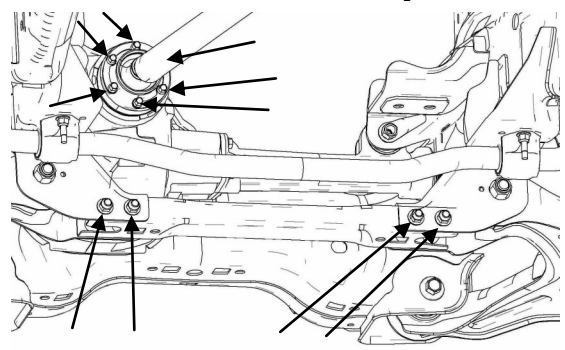

Illustration 4

18. Mark and then trim frame at driver rear control arm mounting location. (**Illustration 5**).
19. Position Sway Bar Bracket (20-52409-9) on frame, aligning hole with outer edge of slot. Mark and drill a 19/32" hole. (**Illustration 6**).

Illustration 5

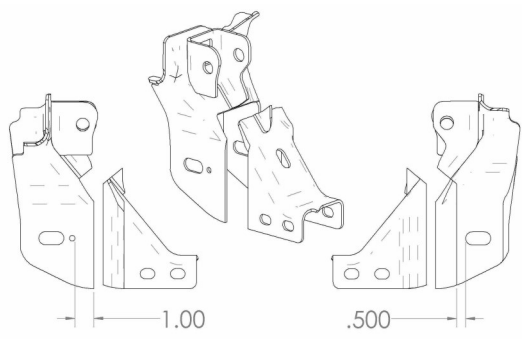

Illustration 6

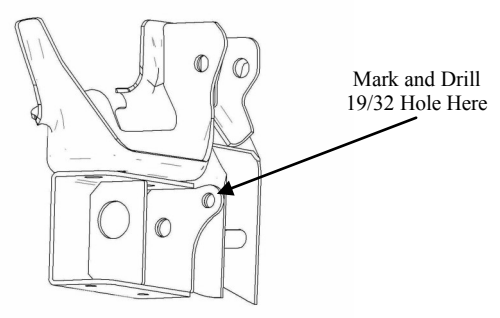
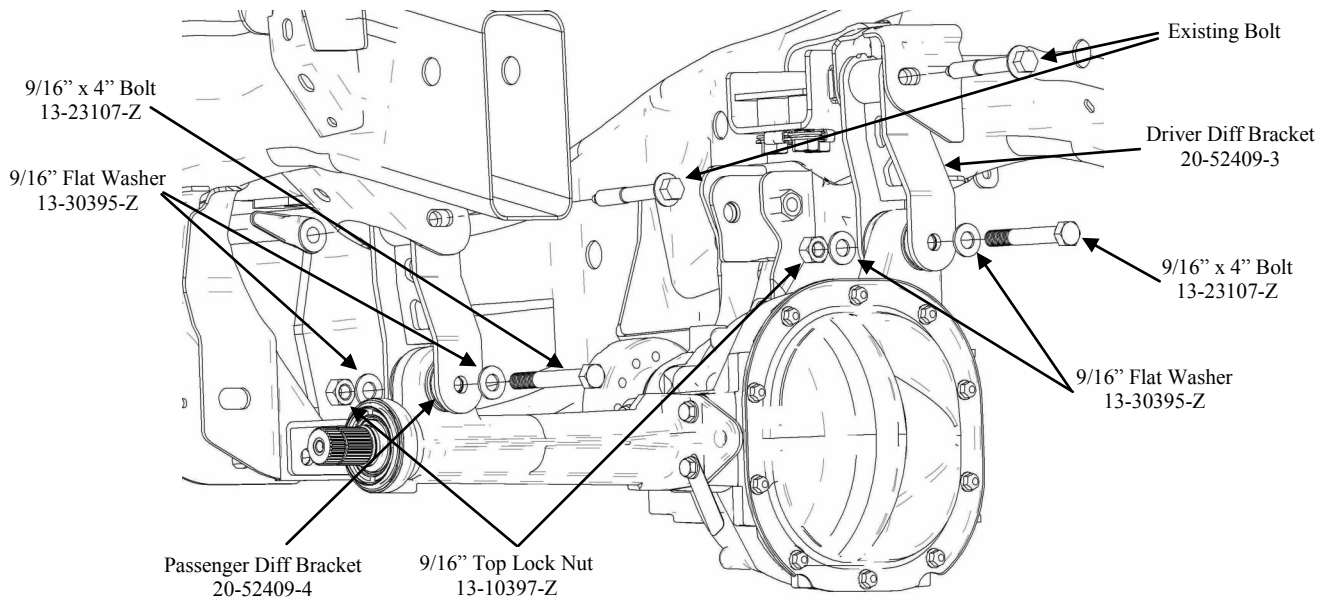

Illustration 7



20. Install Diff Drop Bracket (20-52409-4) on passenger side using original hardware. Do not tighten. **(Illustration 7)**.
21. Install Diff Drop Bracket (20-52409-3) on driver side using original hardware. Do not tighten. **(Illustration 7)**.
22. Raise Front Differential into position in RCD Diff Drop Brackets, and install two 9/16 x 4 bolts with washers through Diff Drop Brackets, and secure with the 9/16 nuts and washers provided. Do not tighten. **(Illustration 7)**.
23. Install Compression Strut Brackets (20-51099-22) on Rear Crossmember (20-52409-2) using 1/2\" hardware supplied. Torque to 65 ft. lbs. **(Illustration 8)**.

Illustration 8

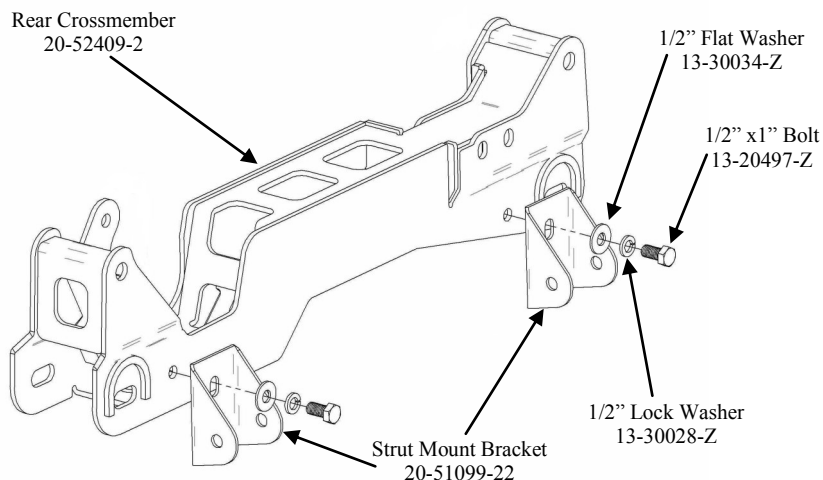
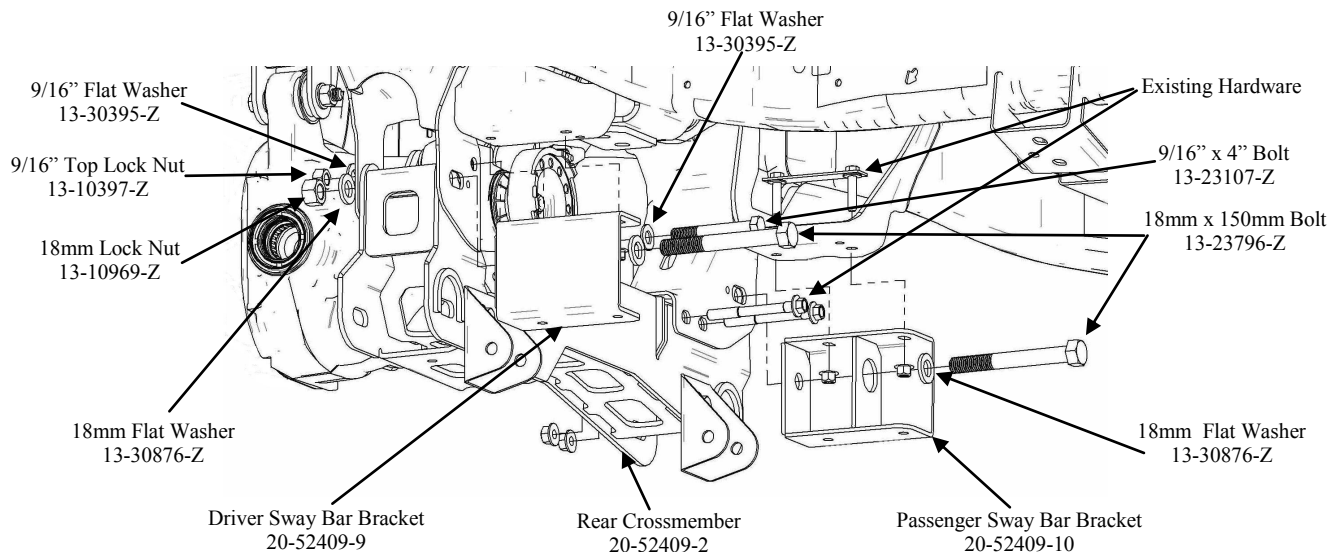

Illustration 9



24. Raise the RCD Rear Crossmember (20-52409-2) into place and install the two 18mm x 150mm bolts through RCD Sway Bar Brackets (20-52409-9 and 20-52409-10). Install the 9/16 x 4 bolt through Sway Bar Bracket, hole previously drilled and differential. Install the two existing bolts on the passenger side. They will go through the RCD Rear Crossmember and Passenger Diff Drop Bracket previously installed. Re-install the original Sway Bar Bolts through new Sway Bar Brackets. Tighten all Diff Brackets at this time. Torque the 18mm bolts to 222 ft. lbs, the 10mm bolts to 66 ft. lbs. ,the 9/16 bolts to 95ft. Lbs. and the existing Diff bolts to 95 ft. lbs. (**Illustration 9**).

25. Re-connect vent hose to front differential.

26. Install RCD Front Crossmember (20-52409-1) using existing hardware. Torque bolts to 222 ft. lbs. (**Illustration 10**).

Illustration 10

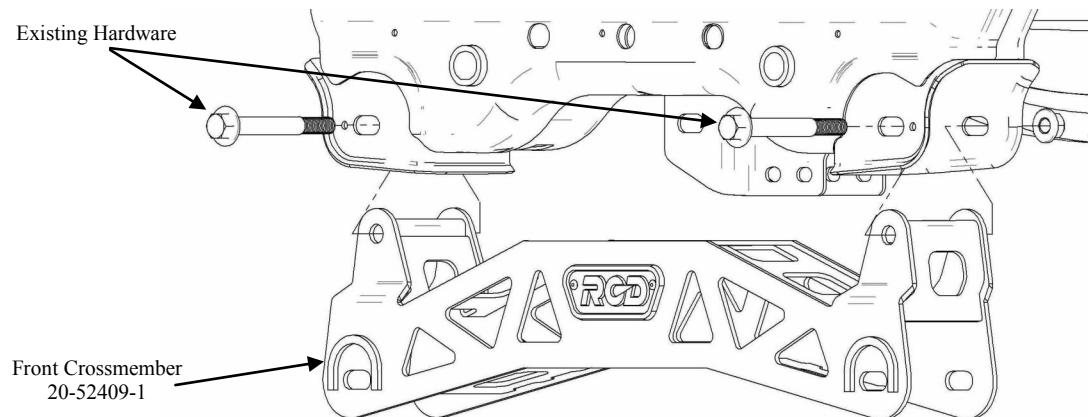

27. Place Driveshaft Spacer (20-52409-8) between driveshaft and differential and secure with 10mm x 80mm socket head bolts. Torque bolts to 45 ft. lbs. (**Illustration 11**).

28. Install both Lower Control Arms into the RCD Crossmembers using the 18mm Cam Bolts, Nuts and Washers provided. Do Not tighten at this time. (**Illustration 12**).

Illustration 12

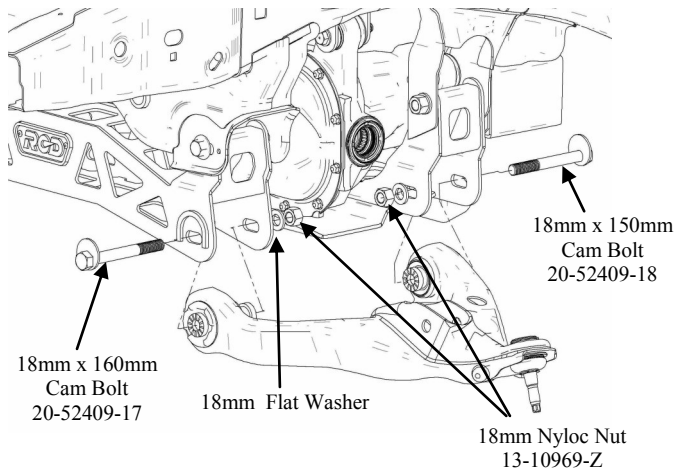
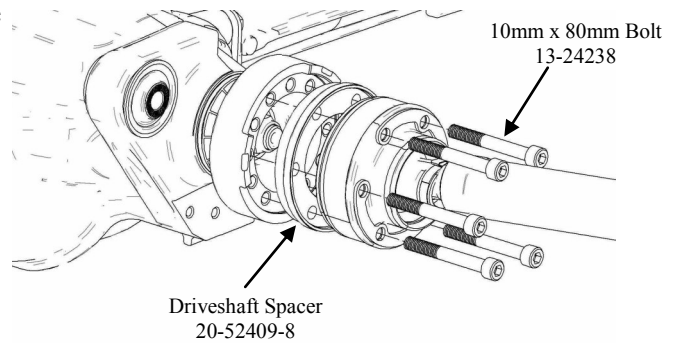

Illustration 11



29. Install the RCD Skidplate under the Differential using 3/8" hardware provided. Torque to 35 ft. lbs. (**Illustration 13**).

Illustration 13

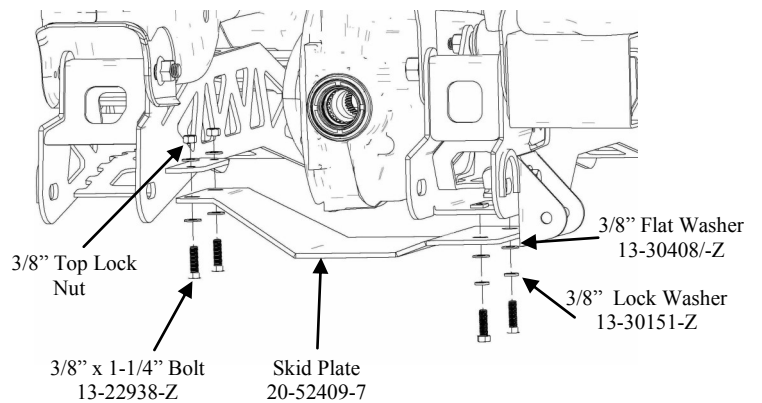
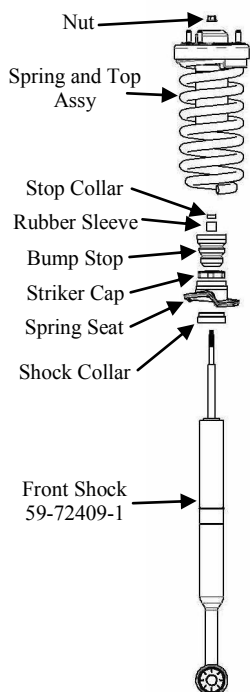

Illustration 14



30. Shock Absorber and Spring Assembly. Using a suitable spring compressor, compress the spring until tension is released from the shock absorber. Remove the nut at the top of the shock absorber and carefully remove the shock. Remove the rubber bump stop from shock absorber. Now remove the striker cap from the shock and slide the spring seat off. Install the shock collar against snap ring on new shock (59-72409-1). Install spring seat. Install new striker cap. Install original bump stop on shaft. This will fit around the black rubber sleeve provided. Place stop collar on shaft. Now insert shock into spring and cap and install nut. Carefully release the spring tension. Note: The shock (59-72409-1) has two snap ring grooves. For 6" lift use the upper groove. If only 4" of lift is desired, move the snap ring to the lower groove. (**Illustration 14**).

31. Install the newly assembled Front Shocks using original hardware. Torque the upper nuts to 35 ft. lbs. Do not tighten lower nut until vehicle is on ground at ride height.

32. Remove the Integrated Wheel End Disconnect from knuckle previously removed. Compress the Integrated Wheel End Disconnect on the bench to collapse the vacuum chamber. While it is collapsed install a vacuum cap on the vacuum port (**Illustration 15**). Install the Integrated Wheel End Disconnect on the outer constant velocity joint housing.

Illustration 15

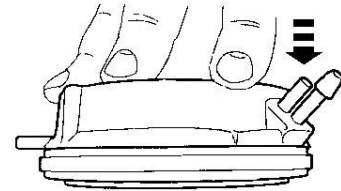

33. Install the new Steering Knuckle to the lower ball joint with nut. Then install the upper ball joint and tie rod. Torque the lower ball joint to 111 ft. lbs. and the upper ball joint and tie rod to 85 ft. lbs. **NOTE: Before installing the new Steering Knuckles, make sure that the Upper and Lower Ball Joint tapers and the Tie Rod taper are all clean and dry. Clean with mineral spirits, if necessary, to remove dirt and grease.**

34. Install the three integrated wheel end disconnect bolts and torque to 11 ft. lbs.

35. Remove the Hub Assembly from knuckle previously removed. Install the Hub assembly to the new RCD Steering Knuckle (20-52409-5D and 20-52409-6P) with the original bolts, being careful not to damage the o-ring. Torque the bolts to 148 ft. lbs. Install the Axle-to-Wheel Hub Nut and torque to 20 ft. lbs. Install the Wheel Speed Sensor and torque to 13 ft. lbs.

36. Re-attach vacuum hose to Integrated Wheel End Disconnect.

37. Install Brake Dust Shield. Slide Brake Rotor onto hub.

38. Remove Brake Line to Frame attaching bolt and install RCD Brake Line Bracket (20-52409-13) using 5/16" hardware provided. (**Illustration 16**).

Illustration 16

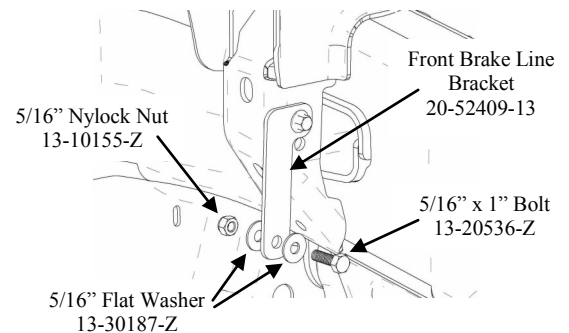

39. Install Brake Caliper Assembly onto Steering Knuckle. Torque Caliper Mount bolts to 148 ft. lbs.

40. Attach Brake Hose to Knuckle using hardware previously removed. Secure the Speed Sensor Line and Vacuum Line.

41. Install Sway Bar to Brackets using 3/8" hardware provided. Attach Sway Bar Links to control arms. Torque 3/8 bolts to 35 ft. lbs. and Sway Bar to Control Arm nuts to 66 ft. lbs. (**Illustration 17**).

Illustration 17

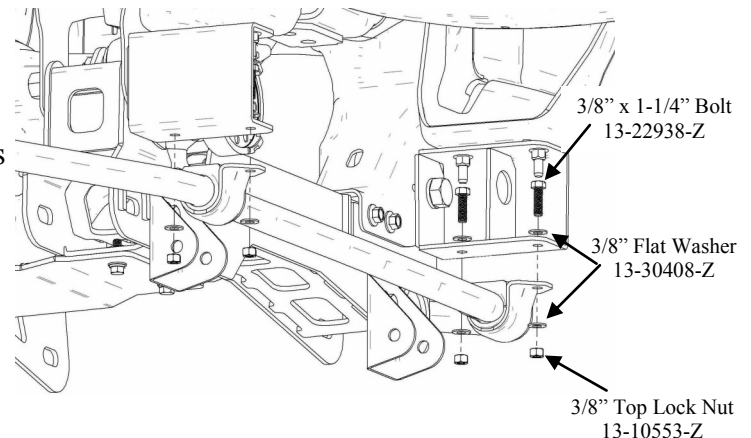

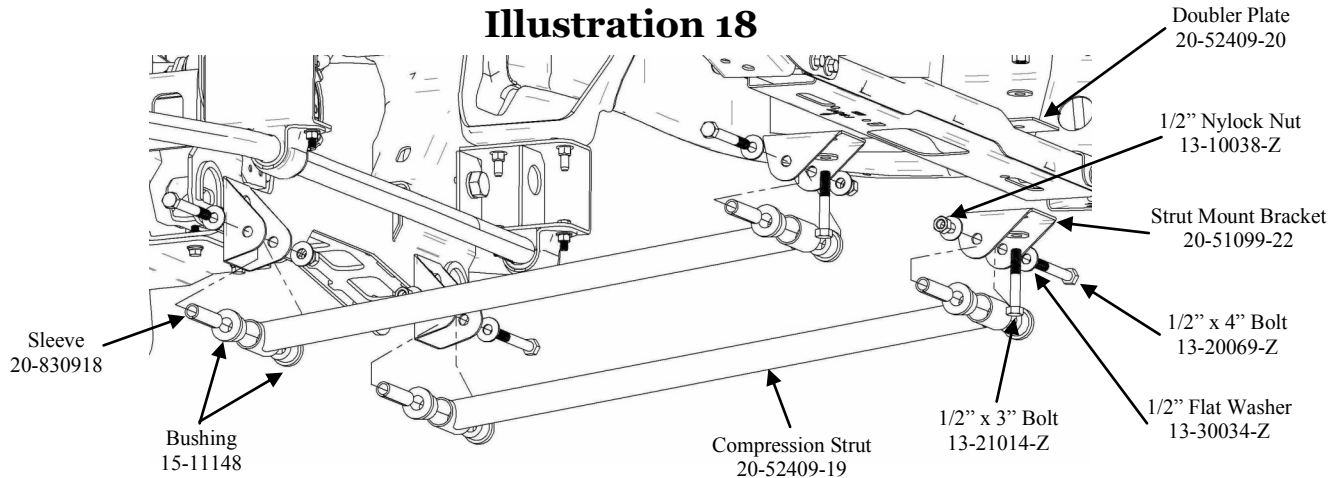

42. Assemble Bushings (15-11148) and Sleeves (20-830918) into both ends of both Compression Struts (20-52409-19). Using 1/2" x 4" Hex Bolts, washers and nuts, insert compression struts into brackets on the back of the RCD Rear Crossmember (**Illustration 18**).
43. Attach Compression Strut Mount Brackets (20-51099-22) to frame using 1/2" x 3" Hex Bolts, washers, nuts and Doubler Plate (20-52409-20) (**Illustration 18**). Install the Compression Struts to the Mounts, and torque all remaining 1/2" hardware to 90 ft. lbs.
44. Install the wheels and tires, and lower the vehicle to the ground. Torque lug nuts to 135 ft-lbs.
45. **Recheck ALL hardware used to install complete suspension system at this time. Anything not tightened to the specified torque needs to be tightened now. Refer to chart on the last page of these instructions for general and specified torque values.**

Rear Installation Instructions

1. Raise the vehicle. If working without a shop hoist support vehicle with suitable safety stands. To do this, put vehicle in gear, block front wheels, both in front and behind tires, then disengage emergency brake. Place floor jack underneath rear axle and raise vehicle. Place suitable safety stands under frame to support vehicle and lower vehicle onto safety stands. Remove rear wheels.
2. Locate the Parking Brake Cable on the driver side of vehicle where it attaches to Rear Spring Hanger. Disconnect the two cables where they come together. Remove Cable, that connects to the Driver side rear brake, from Rear Spring Hanger by compressing tabs and pulling it out. Now remove the Passenger Side Cable from bracket (Some models use a plastic bushing and some use a wire loop).

3. Bolt the RCD E-Brake Cable Bracket (20-52409-14) to the frame using the supplied 1/2" hardware. Now drill a 1 1/32" hole using the new bracket as a guide and install the 5/16" hardware provided. (**Illustration 19**).

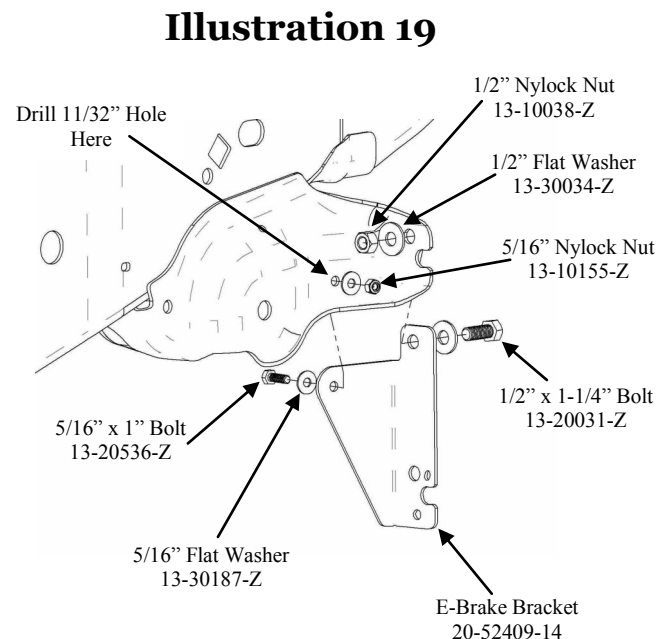

4. Insert Driver Side Cable through hole in new Bracket and attach Passenger Side Cable to bracket using plastic bushing or wire loop previously removed. If the wire type, use 5/16" hardware provided to secure.
5. Connect Cables back together.
6. Locate place where Rear Brake Hoses attach to frame. Disconnect this bracket from frame.
7. Install RCD Brake Line Bracket (20-52409-15) to frame using existing hardware. Attach Brake Line to new Bracket with 5/16" hardware provided.
8. Disconnect Rear Axle Breather Hose from axle. Install 3-1/2" Hose Extension provided.
9. With a floor jack, raise the rear axle enough to relieve tension on the shock absorbers and remove them.

10. Remove the rear U-bolts attaching rear axle to Driver side leaf spring. Carefully lower rear axle.

WARNING: Do not allow axle to hang by any hoses or cables.

11. Insert new Lift Block (20-834220) on axle pad. Make sure the Blocks pins index into the holes in the axle housing spring pad (**Illustration 20**). The wing on the Block faces the inside of the vehicle. Carefully raise rear axle until Block makes contact with leaf spring. Make sure the two pins are aligned with the holes in Block.

12. Re-mount axle to spring using new U-bolts (13-91049), 9/16" Washers, 9/16" High Nuts and existing spring plates. Torque U-bolt nuts to 110 ft. lbs. (**Illustration 20**).

13. Repeat steps 10-12 on Passenger side of vehicle.

14. Install new Bilstein Rear Shock Absorbers (59-72409-2). Using existing hardware, attach shocks to lower axle mounts. Attach shocks to upper frame mounts and torque upper and lower nuts to 66 ft. lbs.

15. Disconnect Rear Driveshaft from Rear Axle. Insert RCD Driveshaft Spacer (20-52409-16) between Driveshaft and Flange and attach using 10mm hardware provided. Torque to 45 ft. lbs. (**Illustration 21**).

16. Install rear tire/wheel assemblies and lower vehicle. Torque lug nuts to 150 ft-lbs.

Illustration 20

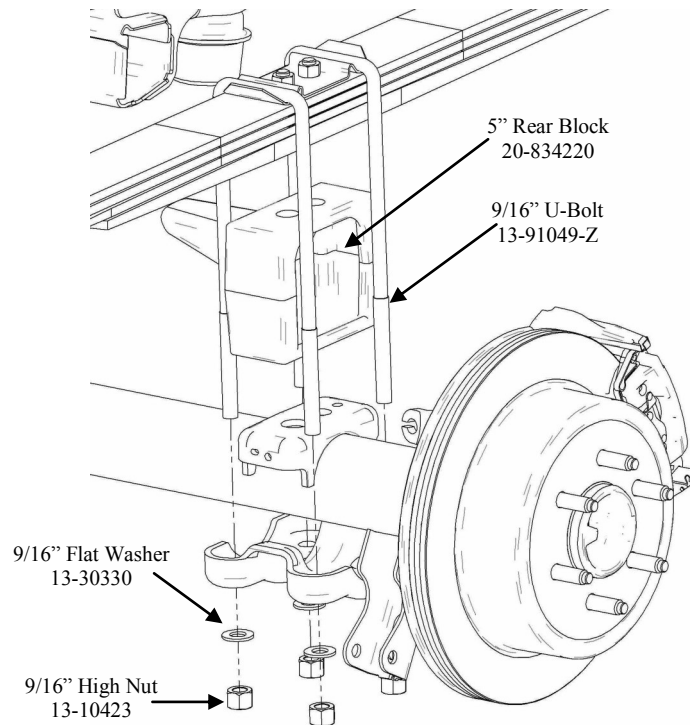
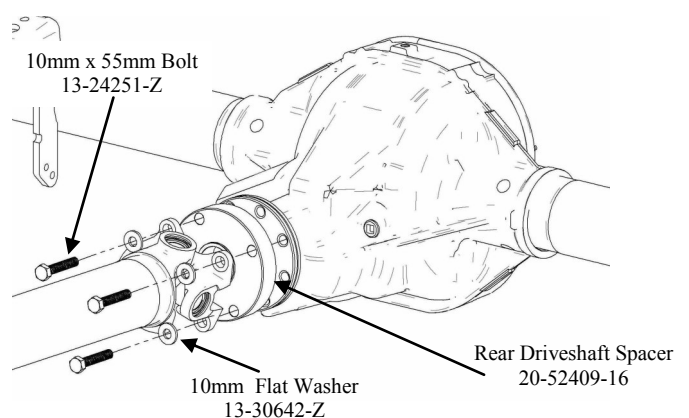

Illustration 21



SOME FINAL NOTES

- After installation is complete, double check that all nuts and bolts are tight. Refer to the torque specifications chart on last page.
- If new tires are installed that are more than 10% taller than original tires, the speedometer must be recalibrated for the Rear Wheel Anti-Lock Brake System to function properly. Contact an Authorized GM dealer for details on recalibration.
- With vehicle on the floor, cycle steering lock to lock and inspect steering, suspension and driveline systems for proper operation, tightness and adequate clearance. Recheck brake/hose fitting for leaks. Be sure all hoses are long enough.
- Have headlights readjusted to proper setting.
- Realign front end to factory specifications. Be sure vehicle is at desired ride height prior to realignment.

Torque Specifications

General Torque Specifications:

5/16"	20 ft. lbs.	M6	9 ft. lbs.
3/8"	35 ft. lbs.	M8	23 ft. lbs.
7/16"	60 ft. lbs.	M10	45 ft. lbs.
1/2"	90 ft. lbs.	M12	75 ft. lbs.
9/16"	160 ft. lbs.	M14	120 ft. lbs.
5/8"	175 ft. lbs.	M16	165 ft. lbs.
3/4"	250 ft. lbs.	M18	220 ft. lbs.

Existing Hardware Torque Specifications:

Wheel Hub-to-Wheel Knuckle Bolts	148 ft. lbs.
Front Differential Mounting Bolts	66 ft. lbs.
Front Driveshaft/Front Differential Pinion Flange Bolts	45 ft. lbs.
Sway Bar to Frame Mounting Bolts	35 ft. lbs.
Lower Control Arm Mounting Bolts	222 ft. lbs.
Sway Bar Link Nuts	66 ft. lbs.
Lower Ball Joint Nut	111 ft. lbs.
Axle Nut	20 ft. lbs.
Upper Ball Joint Nut	85 ft. lbs.
Tie Rod Nut	85 ft. lbs.
Caliper Mount to Steering Knuckle Bolts	148 ft. lbs.
Front Shock, Upper Mount Nuts	35 ft. lbs.
Front Shock, Lower Mount Bolt	351 ft. lbs.
Wheel Lug Nuts	150 ft. lbs.
U-Bolt Nuts	110 ft. lbs.
Rear Shock, Upper and Lower Mount Nuts	66 ft. lbs.
Anti-lock Brake Sensor Bolt	13 ft. lbs.