



1/13/03

**'97-'01 FORD 2WD F250/350
4" SUSPENSION SYSTEM**

P/N. 42399

INSTALLATION INSTRUCTIONS

NOTE: Each Lift Kit, and options to Lift Kits, are packaged separately. Therefore installation procedures are covered in separate instructions. Familiarize yourself with each set of instructions before beginning.

Parts List

<u>Item</u>	<u>Description</u>	<u>Qty</u>	<u>Illus.</u>
<u>Box 1 of 4</u>			
20-52399-3	Bracket, Radius Arm Drop (Drvr.)	1	8
20-52399-4	Bracket, Radius Arm Drop (Pass.)	1	8
20-52399-7	Bracket, Front Sway Bar Drop (Drvr.)	1	10
20-52399-8	Bracket, Front Sway Bar Drop (Pass.)	1	10
20-67941	Hardware Pack Containing: (Sway Bar Drop)		
20-52399-10	Spacer, Sway Bar Upper Mount	2	10
13-21456-Z	Hex Bolt, 1/2" - 13 x 1 1/2" Lg. Gr. 8	2	10
13-21118-Z	Hex Bolt, 7/16" - 14 x 1 1/4" Lg. Gr. 8	4	10
13-30382-Z	Flat Washer, 1/2" Hrdn.	4	10
13-30304-Z	Flat Washer, 7/16" Hrdn.	8	10
13-10514-Z	Top Lock Nut, 1/2" - 13 Gr. C	2	10
13-10384-Z	Top Lock Nut, 7/16" - 14 Gr. C	4	10
20-67967	Hardware Pack Containing: (Radius Arm Drop)		
13-21456-Z	Hex Bolt, 1/2" - 13 x 1 1/2 Lg. Gr. 8	12	8
13-30382-Z	Flat Washer, 1/2" Hrdn.	24	8
13-10514-Z	Top Lock Nut, 1/2" - 13 Gr. C	12	8
20-68253	Hardware Pack Containing: (Bumpstop Extension)		
20-52399-11	Front Bumpstop Extension	2	
13-20053-Z	Hex Bolt, 3/8" - 16 x 1" Lg. Gr. 5	2	
13-30012-Z	Flat Washer, 3/8" SAE	4	
13-10022-Z	Nyloc Nut, 3/8" - 16	2	
<u>Box 2 of 4</u>			
20-52399-1	Bracket, Front Pivot Drop (Drvr.)	1	5
20-52399-2	Bracket, Front Pivot Drop (Pass.)	1	6
20-52399-12	Brace, Pivot Drop Crossover	1	9
20-52399-9	Brace, Front Pivot Drop	1	7
50-083403	Pitman Arm	1	
20-67954	Hardware Pack Containing: (Front Pivot Drop)		
13-22132-Z	Hex Bolt, 1/2" - 13 x 2 1/4" Lg. Gr. 8	4	5,7
13-21456-Z	Hex Bolt, 1/2" - 13 x 1 1/2" Lg. Gr. 8	9	5,6
13-30382-Z	Flat Washer, 1/2" Hrdn.	26	5,6,7
13-10514-Z	Top Lock Nut, 1/2" - 13 Gr. C	13	5,6,7

20-67980	Hardware Pack Containing: (Pilot Drop Crossover)		
13-21378-Z	Hex Bolt, 1/2" - 13 x 3 3/4" Lg.	2	9
13-30034-Z	Flat Washer, 1/2" SAE	4	9
13-10038-Z	Nyloc Nut, 1/2" - 13	2	9
15-11148	Bushing, Red	4	9
20-832751	Sleeve, 3/4" x 2.12" Lg.	2	9

Box 3 of 4

20-20127-1	Coil Springs, (Front)	2	3,4
------------	-----------------------	---	-----

Box 4 of 4

BE5-6140	Shock Absorbers (Front)	2	
BE5-2816	Shock Absorbers (Rear)	2	

BEFORE YOU BEGIN

- ❑ Installation requires a professional mechanic. Use of appropriate power tools, a Ford Service Manual and a shop hoist can greatly reduce installation time.
- ❑ Prior to installation, carefully inspect the vehicle's steering and drive train systems, paying close attention to the Tie Rod ends, Pitman and Idler Arms, Ball Joints and wheel bearing preload. Also check steering-to-frame and suspension-to-frame attaching points for stress cracks. The overall vehicle must be in excellent working condition; repair or replace worn parts.
- ❑ Always use **new** cotter pins (these items are not supplied) when replacing them.
- ❑ Foot-pound torque readings are listed on Torque Specification Chart at the end of the instructions unless specifically stated in the instruction. Apply Loctite Retaining Compound on specified bolts during installation. **DO NOT USE AN IMPACT WRENCH TO TIGHTEN ANY OF THE BOLTS.**
- ❑ Read instructions carefully and study the illustrations before attempting installation. *Race Care Dynamics* is not responsible for damage, failure or injury resulting from improper installation or parts substitution of this kit.
- ❑ Check all parts and hardware against the parts list to assure that your kit is complete. Report any shortages to *Race Car Dynamics* at (1-619-588-4723). The parts and hardware supplied are of high-grade material and must not be replaced by inferior parts or failure may result.

- ❑ Separate parts according to the areas they will be used. Placing the hardware with brackets before you begin will save installation time.
- ❑ This kit is supplied as a bolt-on assembly. Do not weld anything to the components and do not weld the components to the vehicle.
- ❑ All components in this kit come with a protective coating. Do not plate (i.e. chrome, cadmium, zinc, etc.) or otherwise alter the finish in any way. This could weaken the structural strength of the components.
- ❑ Secure and properly block vehicle prior to beginning installation.
- ❑ Always wear safety glasses when using power tools.

PLEASE NOTE

- **WARNING:** DO NOT USE WHEEL SPACERS
- Front end realignment is necessary
- Speedometer recalibration is necessary if bigger tires (10% more than stock diameter) are installed.
- Retains factory sway bar.
- Clears 33" x 12.50 tires on 16.5" x 9.75 wheels or 35" x 12.50" with minor bumper trimming.
- Headlights will have to be adjusted after install

****The following special tools will be required for the proper removal and/or installation of this kit****

Pitman Arm Puller
#T64P-3509-F

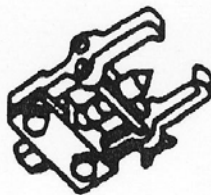

FRONT DISASSEMBLY

1. Raise the vehicle and remove wheels and tires. If working without a shop hoist, put vehicle in gear, set emergency brake, and block rear wheels, in front and behind tires. Loosen Lug nuts. Place floor jack under lower control arm's front crossmember and raise vehicle. Place safety jack stands under frame rails, behind front wheel wells and lower frame onto stands. Remove front wheels and tires.

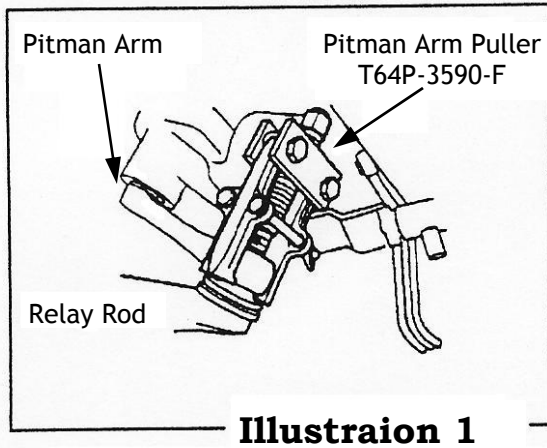

2. Use Pitman Arm Puller (T64P-3590-F) to separate relay rod from Pitman Arm (Illustration 1).

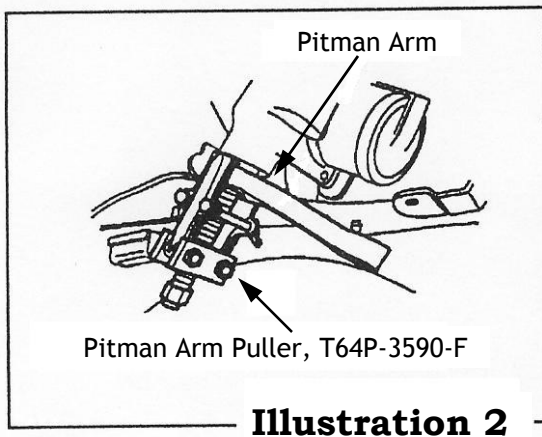

3. With steering at center, scribe an index mark on the face of steering gear shaft. Use puller to remove Pitman Arm from steering gear shaft (Illustration 2).

4. Disconnect sway bar from drop links, remove sway bar retainer brackets and remove sway bar from vehicle (Illustration 3).

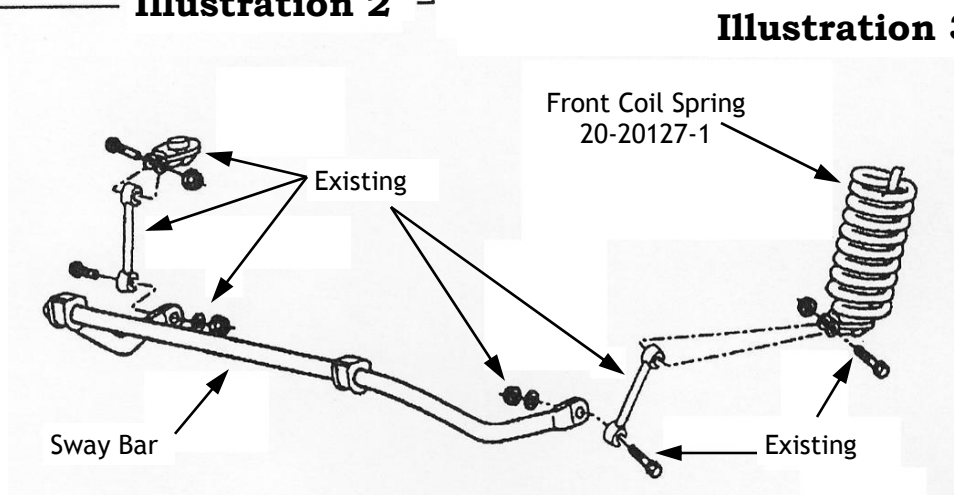

5. Use suitable floor jack to support the front pivot axle beam assembly near the front spindle. Remove upper spring retainer (Illustration 4).

Spring Retainer

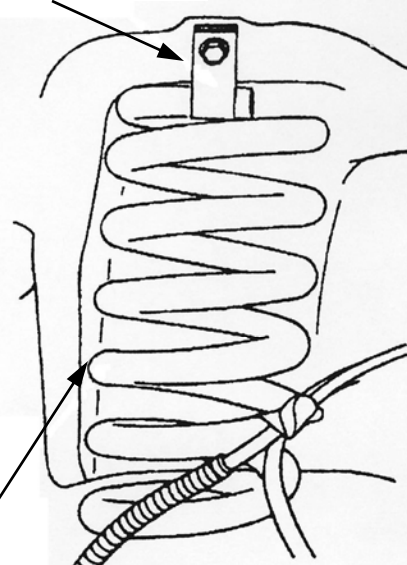

Front Coil Spring
20-20127-1

Illustration 4

6. Lower front pivot axle beam until front coil spring is free from upper spring seat. Use an extension to reach through the top of the coil spring and remove the lower spring retainer. Remove Spring.

7. Support front pivot axle beam at several points to prevent it from tipping or falling over. Disconnect pivot axle beam from the front pivot bracket.

WARNING: The beam is very heavy - Exercise caution when disconnecting them to avoid the possibility of injury.

8. Remove front pivot bracket from vehicle frame.

9. Locate driver's side radius arm drop bracket. Disconnect radius arm from the radius arm drop bracket. Remove radius arm drop bracket from vehicle.

10. Repeat steps 5 through 9 on opposite side of vehicle.

FRONT ASSEMBLY

1. Loosely install Front Pivot Drop Bracket (20-52399-1 Drvr) into existing hole locations. Use the Bracket as a guide and mark the area where existing crossmembers is to be drilled. Remove bracket and drill 1/2" holes at the marked locations (**Illustration 5**). Install bracket using hardware provided and torque nuts to 90 ft. lbs.

NOTE: A right angle drill may be necessary when drilling new pilot holes.

CAUTION: When drilling new pilot holes, check backside and surrounding areas for vacuum lines, gas lines, and water hoses so not to damage while drilling.

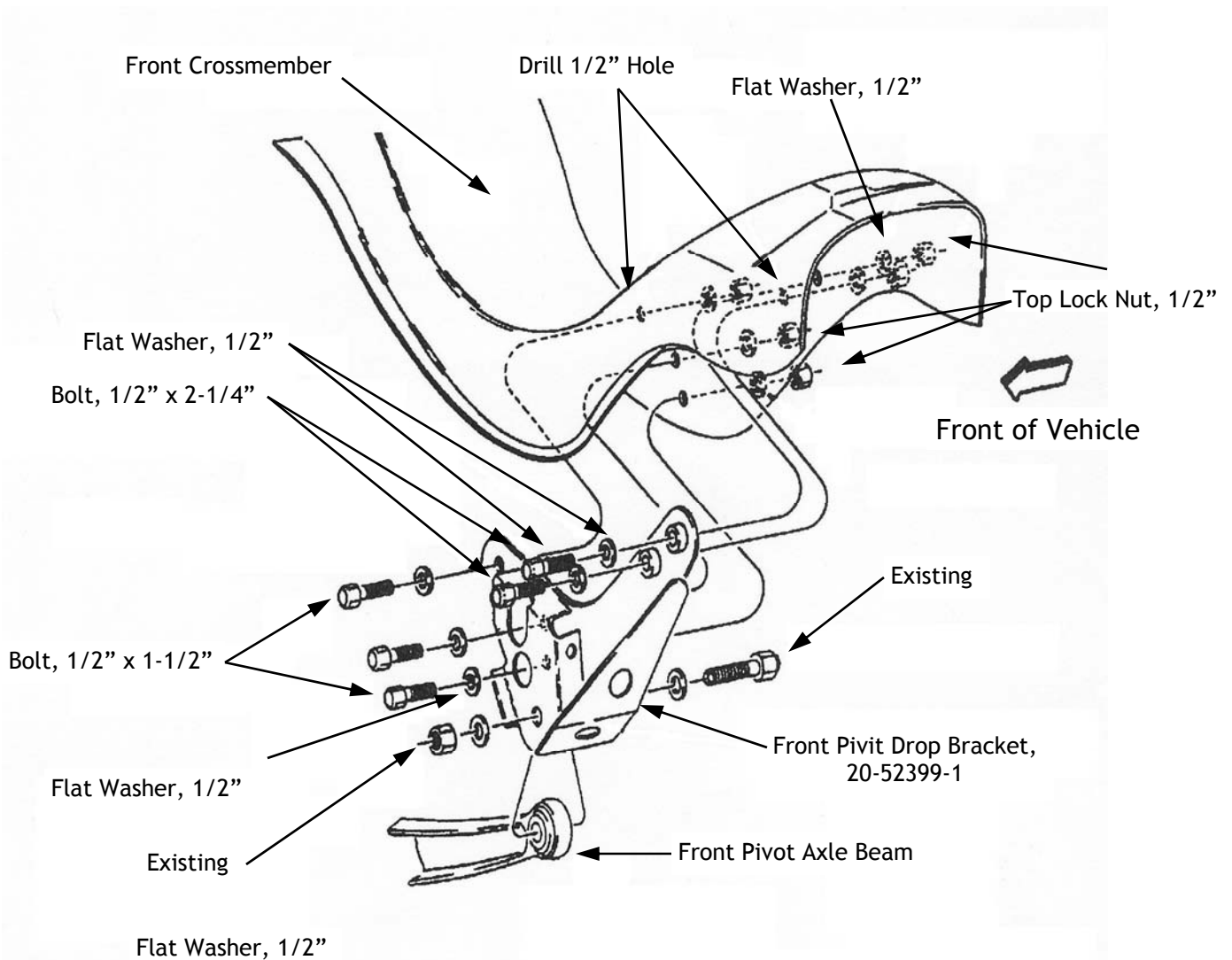

Illustration 5

2. Loosely install Front Pivot Drop Bracket (20-52399-5 Pass) into existing hole locations. Use the Bracket as a guide and mark the area where existing crossmember is to be drilled. Remove bracket and drill $\frac{1}{2}$ " holes at the marked locations (Illustration 6). Install bracket using hardware provided and torque nuts to 90 ft. lbs.
3. Install driver and passenger front pivot axle beams into new Front Pivot Drop Bracket using hardware previously removed. Torque nuts to 130 ft. lbs.

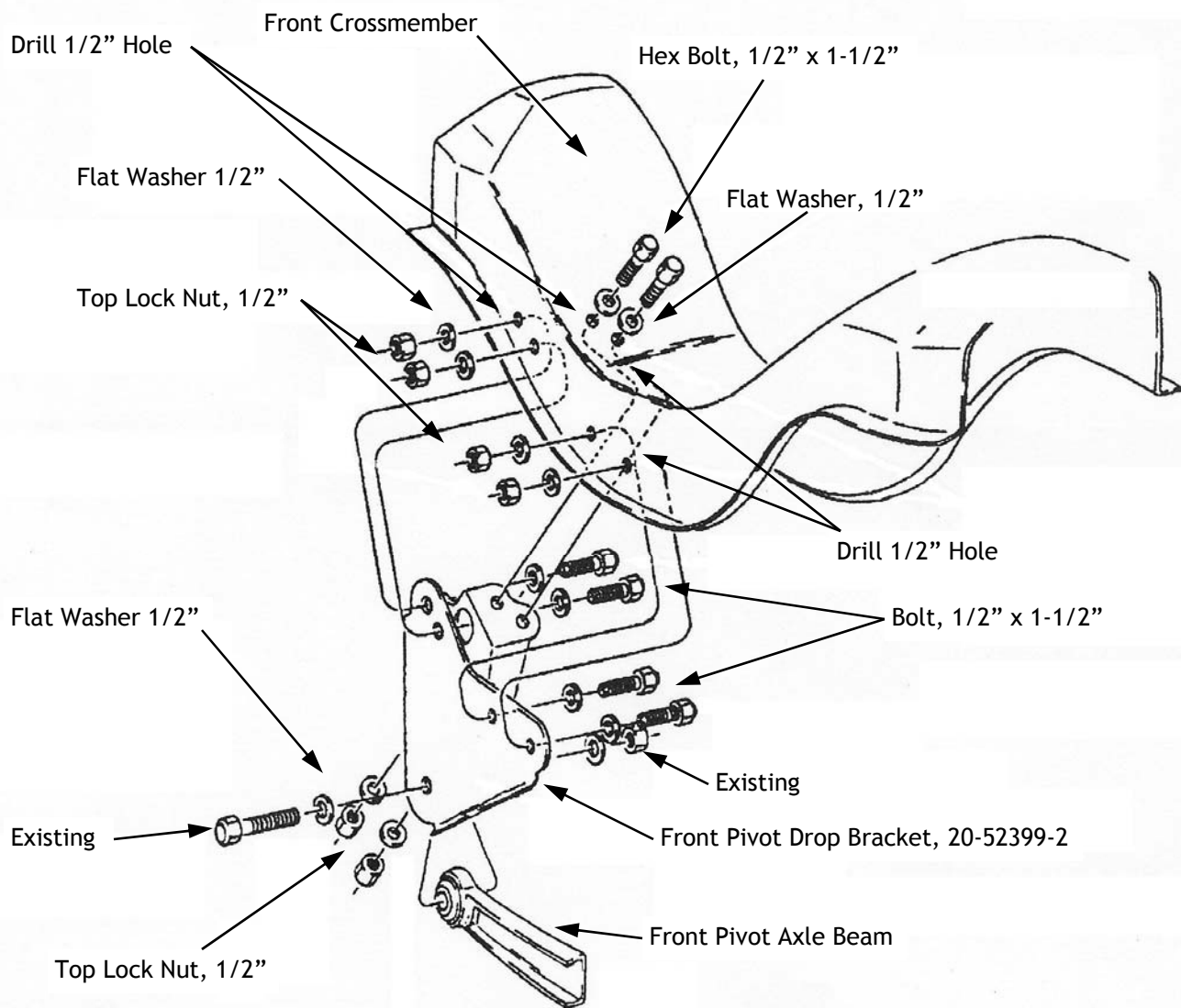

Illustration 6

 Front of Vehicle

- Loosely install Front Drop Brace (20-52399-9) into existing hole located on driver's side front Pivot Drop Bracket (Illustration 7). Use the brace as a guide and mark then drill $\frac{1}{2}$ " holes at the marked locations. Install Brace using hardware provided and torque nuts to 90 ft. lbs.

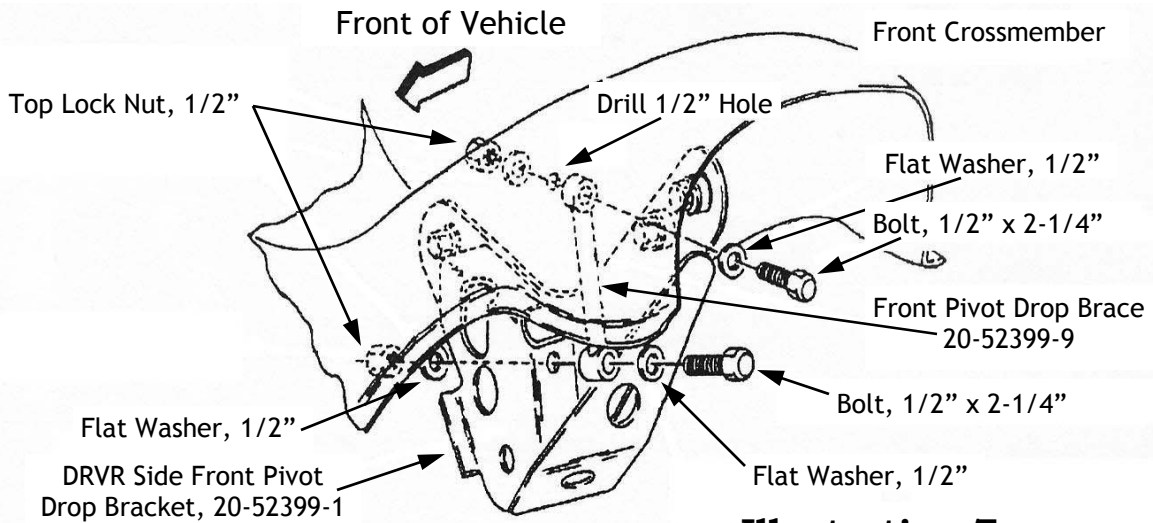

Illustration 7

- Install Radius Arm Drop Bracket (20-52399-3 Drvr.) and (20-52399-4 Pass) to existing hole locations in vehicle frame (Illustration 8) using hardware provided. Torque nuts to 90 ft. lbs.

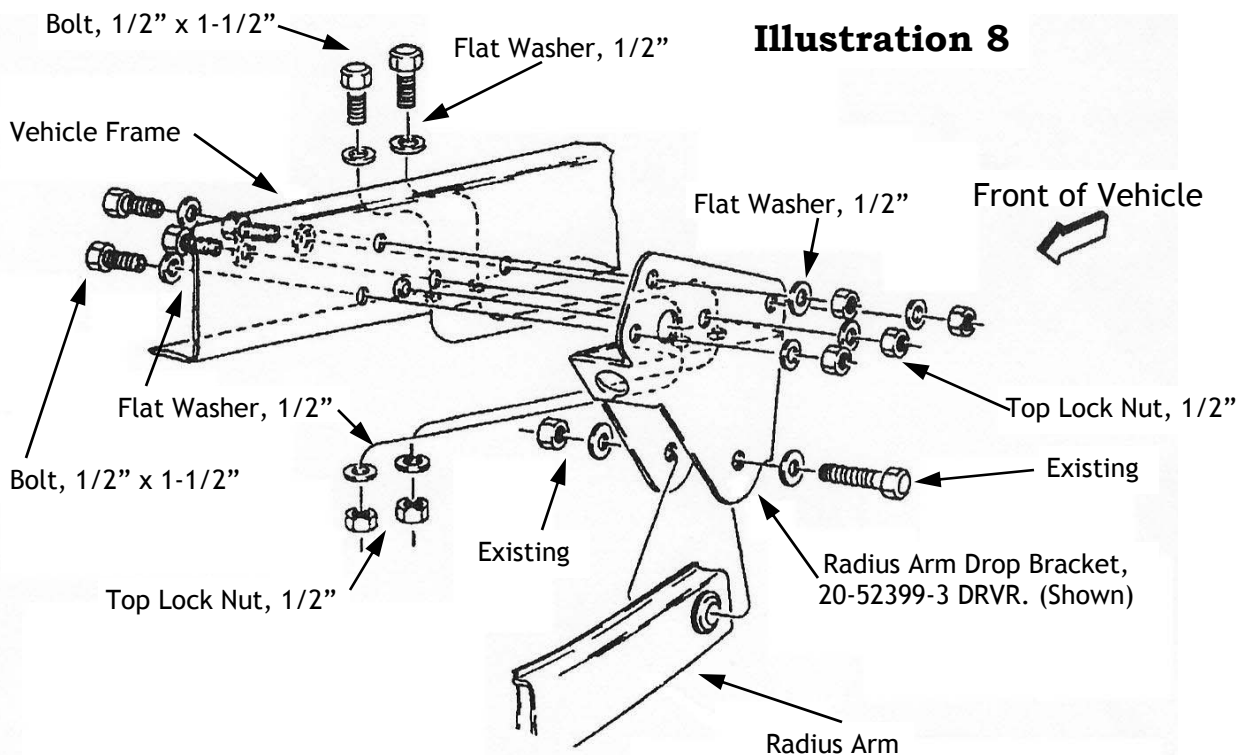

Illustration 8

6. Install existing radius arms into the new Radius Arm Brackets using hardware previously removed. Torque nuts to 185 ft. lbs.

7. Attach Pilot Drop Crossover Brace (20-52399-12) to new Radius Arm Drop Bracket using Bushing (15-11148) and Sleeve (20-832751) with hardware provided. (Illustration 9).

8. Attach Front Sway Bar Drop Bracket (20-52399-7 Drvr.) and (20-52399-8 Pass) to existing sway bar mounting area (Illustration 10). Use the front sway bar bracket upper mount as a guide to mark hole locations to be drilled. Remove Sway Bar Drop Bracket and drill 1/2" hole. Fasten using hardware provided. Torque 7/16" nuts to 60 ft. lbs., and 1/2" nuts to 90 ft. lbs.

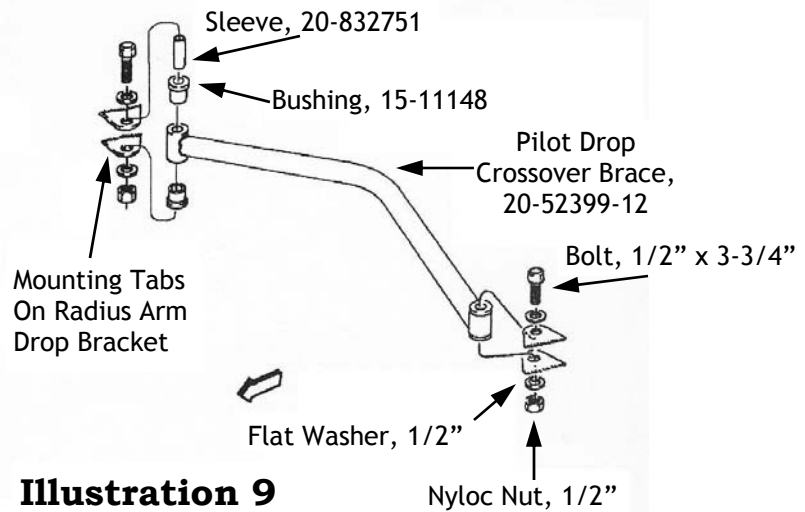

Illustration 9

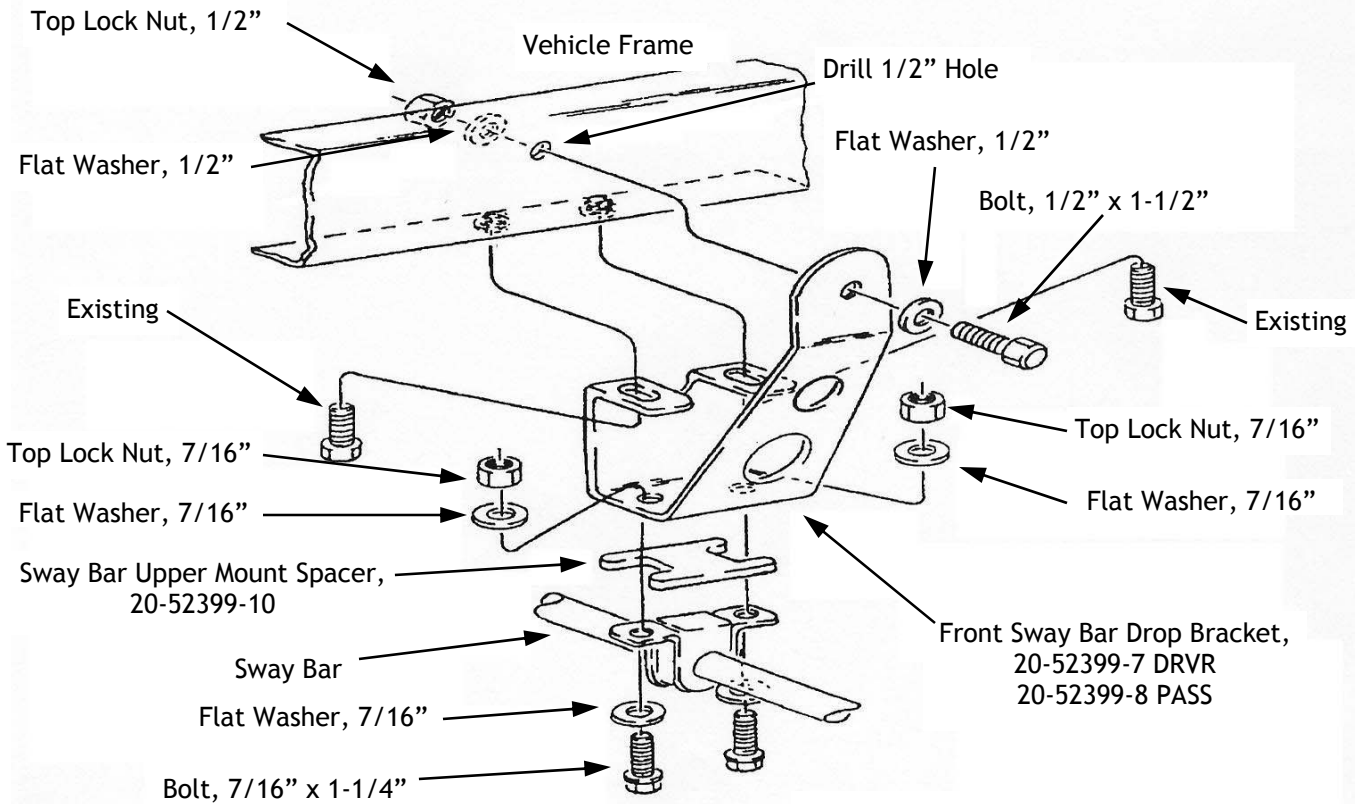

Illustration 10

9. Install existing sway bar to new Sway Bar Drop Brackets using Sway Bar Upper Mount Spacer (20-52399-10) and existing hardware. See torque specifications for value.

10. Locate and remove existing front bumpstops from the bottom of the vehicle frame. Attach existing bumpstop to Front Bumpstop Extension (20-52399-11) using the original hardware. Install front bumpstop assembly to the frame rail at the original bumpstop location using hardware provided. Torque 3/8" nuts to 30 ft. lbs.

11. Install new supplied Pitman Arm (083403) into position, noting any indexing marks and making sure that the steering wheel is centered. Use existing nut and install new cotter pin. Torque nut to 200ft. lbs.

12. Install new Front Coil Spring (20-20127-1) onto the lower axle beam mounting area. Reinstall the lower spring retainer and nut. Torque nut to 99 ft. lbs. With a floor jack under lower axle beam raise the jack until coil spring seats into the existing upper coil spring mount. Attach upper coil spring retainer using existing hardware previously removed. Torque bolt to 26 ft. lbs.

13. Install new longer Front Shock Absorbers (BE5-6140). Torque according to specifications.

14. Install new longer Rear Shock Absorbers (BE5-2816). Torque nuts to 46 ft. lbs.

15. Lower vehicle. With the vehicle at ride height, install steering linkage to new Pitman Arm using existing nut and new cotter pin. Torque nut to 67 ft. lbs.

SOME FINAL NOTES

- ❑ After installation is complete, double check that all nuts and bolts are tight. Refer to the chart on the last page for torque specifications.
- ❑ If new tires are installed that are more than 10% taller than original tires, the speedometer must be recalibrated for the anti-lock brake system (if applicable) to function properly. Contact an authorized Ford dealer for details on recalibration.
- ❑ With vehicle on floor, cycle steering lock to lock and inspect steering, suspension and driveline systems for proper operation, tightness and adequate clearance. Recheck brake/hose fitting for leaks. Be sure all hoses are long enough.
- ❑ Have headlights readjusted to proper setting.
- ❑ Realign front end to factory specifications. Be sure vehicle is at desired ride height prior to realignment.

TORQUE SPECIFICATIONS (Grade 8 & Class 10.9)

5/16" NUTS	20 ft. lbs.	M6	9 ft. lbs.
3/8" NUTS	35 ft. lbs.	M8	23 ft. lbs.
7/16" NUTS	60 ft. lbs.	M10	45 ft. lbs.
1/2" NUTS	90 ft. lbs.	M12	75 ft. lbs.
9/16" NUTS	160 ft. lbs.	M14	120 ft. lbs.
5/8" NUTS	175 ft. lbs.	M16	165 ft. lbs.

EXISTING TORQUE SPECIFICATIONS

Pitman Arm Nut	200 ft. lbs.
Radius Arm Nut	185 ft. lbs.
Front Pivot Axle Beam Nut	139 ft. lbs.
Lower coil Spring retainer nut	99 ft. lbs.
Relay Rod nut	67 ft. lbs.
Shock Absorber to Spring/Shock Tower nut (front)	30 ft. lbs.
Shock Absorber lower retainer nut (front)	60 ft. lbs.
Shock Absorber to Frame nut (rear)	46 ft. lbs.
Shock Absorber to Axle nut (rear)	46 ft. lbs.
Sway Bar Extension Nut	60 ft. lbs.
Sway bar bolt	36 ft. lbs.
Coil Spring retainer Bolt	26 ft. lbs.