



Rev. 1/5/04

**'97-'03 FORD F/S 4WD  
IFS F150  
4.2L OR 4.6L WITH 4R70W Transmission  
4"-5" SUSPENSION SYSTEM**

**P/N. 10-42097**

### **INSTALLATION INSTRUCTIONS**

**NOTE:** Each Lift Kit, and options to Lift Kits, are packaged separately. Therefore, installation procedures are covered in separate instructions. Familiarize yourself with each set of instructions before beginning.

Part List

<u>Item</u>	<u>Description</u>	<u>Qty</u>	<u>Illus.</u>
<u>Box 1 of 5</u>			
20-52097-1	Front Crossmember	1	20,22,25
20-52097-2	Rear Crossmember	1	21,24,27
20-52097-3	Crossmember Support Brkt. (Drvr.)	1	27
20-52097-4	Crossmember Support Brkt. (Pass.)	1	27
20-52097-5	Differential Drop Bracket	2	18,19,22
20-67174	Hardware Pack Containing: (Vent Hose)		
20-832335-1	Vent 3" Hose Extension -	1	23
20-832335-2	Vent Hose Connector	1	23
20-67408	Hardware Pack Containing: (FRONT BUMPSTOP)		
20-52097-17	Bracket, Bumpstop	2	29
13-20081-Z	Hex Bolt, 3/8" - 16 x 1-1/4" Lg.	2	29
13-30012-Z	Flat Washer, 3/8" SAE	4	29
13-10022-Z	Nyloc Nut, 3/8" - 16	2	29
20-66524	Hardware Pack Containing: (FRONT & REAR CROSSMEMBER)		
13-21950-Z	Hex Bolt, 5/8" - 11 x 5-1/2" Lg. Gr.8	4	
13-20625-Z	Hex Bolt, 1/2" - 13 x 6" Lg. Gr.5	1	25
13-30369-Z	Flat Washer, 5/8" Hrdn.	8	
13-30034-Z	Flat Washer, 1/2" SAE	2	25
13-10345-Z	Top Lock Nut, 5/8" - 11	4	
13-10038-Z	Nyloc Nut, 1/2" - 13	1	25
11-13737	Crossmember Spacer, (3-3/8")	1	25
20-830502	Load Washer	1	25
13-90490	Loctite Compound	2	
20-66901	Hardware Pack Containing: (COMPRESSION SUPPORT BRACKET)		
13-20142-Z	Hex Bolt, 7/16"-14 x 1-1/4" Lg. Gr. 5	4	27
13-30117-Z	Flat Washer, 7/16" SAE	8	27
13-10133-Z	Nyloc Nut, 7/16"-14	4	27
20-67057	Hardware Pack Containing: (DIFFERENTIAL DROP)		
13-21976-Z	Hex Bolt, 1/2"-13 x 3-3/4" Lg. Gr. 8	1	18
13-21963-Z	Hex Bolt, 12mm-1.75 x 100mm Lg. Gr.10.9	1	22
13-30382-Z	Flat Washer, 1/2" Hrdn	2	18
13-30546-Z	Flat Washer, 12mm Hrdn.	2	22
13-10514-Z	Top Lock Nut, 1/2"-13 Gr. C	1	18

20-68032	Hardware Pack Containing: (FRONT SWAY BAR LINK)		
20-832803	Sway Bar Link Spacer (6-1/2" Lg.)	2	32
13-22743-Z	Button Head, 1/2"-13 x 3" Lg.	4	32
15-11382	Bushing, Sway Bar Link	8	32
13-30668-Z	Washer, Retainer	4	32
20-67148	Hardware Pack Containing: (BRAKE LINE EXTENSION)		
20-832595	Brake Line Extension Bracket	2	31
13-21157-Z	Hex Bolt, 5/16"-18 x 3/4" Lg.	2	31
13-30187-Z	Flat Washer, 5/16" SAE	4	31
13-10155-Z	Nyloc Nut, 5/16"-18	2	31

**Box 2 of 5**

20-52097-19D	Front Spindle (Drvr.)	1	27
20-52097-20P	Front Spindle (Pass.)	1	27
20-68370	Hardware Pack Containing: (COTTER PINS)		
13-90607	Cotter Pins 1/8" x 1-1/2"	8	

**Box 3 of 5**

20-52097-21	Block "RCD", Torsion Bar Drop	2	29
20-52097-15	Compression Strut Rear Mount	1	28
20-52097-16	Compression Strut Assy.	1	28
20-66875	Hardware Pack Containing: (COMPRESSION STRUT)		
15-11148	Bushing, Red	6	28
20-830918	Sleeve, 3/4" x 2-3/4" Lg.	2	28
20-831789	Sleeve, 3/4" x 3-15/16" Lg.	1	28
13-21183-Z	Hex Bolt, 1/2"-13 x 5-1/2" Lg.	1	28
13-20069-Z	Hex Bolt, 1/2"-13 x 4" Lg.	2	28
13-20142-Z	Hex Bolt, 7/16"-14 x 1-1/4" Lg.	1	28
13-30034-Z	Flat Washer, 1/2"	6	28
13-30117-Z	Flat Washer, 7/16"	2	28
13-10038-Z	Nyloc Nut, 1/2"-13	3	28
13-10133-Z	Nyloc Nut, 7/16"-14	1	28
20-67083	Hardware Pack Containing: (TORSION BAR DROP)		
13-21183-Z	Hex Bolt, 1/2"-13 x 5-1/2" Lg.	2	29
13-21404-Z	Hex Bolt, 1/2"-13 x 4-1/2" Lg.	4	29
13-30034-Z	Flat Washer, 1/2"	12	29
13-10038-Z	Nyloc Nut, 1/2"-13	6	29
20-830502	Load Washer	2	29
20-831932	Spacer, 3/4" x 1-1/4" Lg.	2	29

**Box 4 of 5**

BE5-6138	Shock Absorber (Front)	2
BE5-6093	Shock Absorber (Rear)	2

**Box 5 of 5**

13-70026-1	Add-a-Leaf, 97-00 F150 Ford	2	33
20-68240	Hardware Pack Containing: (ADD-A-LEAF)	1	
13-90750	Center Pins	2	
13-90438	U-bolt, 9/16"-18 x 3-1/4" x 10-5/8"	4	
20-68188	Hardware Pack Containing: (9/16" U-bolt)		
13-30330	Flat Washer, 9/16" Hrdn.	8	
13-10423	High Nut, 9/16"-18	8	
20-68344	Hardware pack Containing: (CLAMPS)	1	
13-90737-1	Clamp, 2-1/2" Clip Leaf Spring	4	
13-90737-2	Clamp, 2-1/2" Cap Leaf Spring	4	

**BEFORE YOU BEGIN**

- Installation requires a professional mechanic.
- Prior to installation, carefully inspect the vehicle's steering and drive train systems, paying close attention to the Tie Rod ends, Pitman and Idler Arms, Ball Joints and wheel bearing preload. Also check steering-to-frame and suspension-to-frame attaching points for stress cracks. The overall vehicle must be in excellent working condition; repair or replace worn parts.
- Always use **new** cotter pins (these items are not supplied) when replacing them.
- Foot pound torque readings are listed on Torque Specification Chart at the end of the instructions unless specifically stated in the instruction. Apply Loctite Retaining Compound on specified bolts during installation. **DO NOT USE AN IMPACT WRENCH TO TIGHTEN ANY OF THE BOLTS.**

- Read the instructions carefully and study the illustrations before attempting installation. *Race Car Dynamics* is not responsible for damage, failure or injury resulting from improper installation or parts substitution of this kit.
- Check all parts and hardware against the parts list to assure that your kit is complete. Report any shortages to *Race Car Dynamics* at (1-619-588-4723). The parts and hardware supplied are of high grade material and must not be replaced by inferior parts or failure may result.
- Separate parts according to the areas they will be used. Placing the hardware with brackets before you begin will save installation time.
- This kit is supplied as an bolt-on assembly. Do not weld anything to the components and do not weld the components to the vehicle.
- All components in this kit come with a protective coating. Do not plate (i.e. chrome, cadmium, zinc etc.) or otherwise alter the finish in any way. This could weaken the structural strength of the components.
- Secure and properly block vehicle prior to beginning installation.
- Always wear safety glasses when using power tools.

### **PLEASE NOTE**

- **WARNING: DO NOT USE WHEEL SPACERS**
- Front end realignment is necessary.
- Speedometer recalibration is necessary if bigger tires ( 10% more than stock diameter ) are installed.
- Clears 35" x 12.50" tires on 16" x 8" wheels, requires wheels with a maximum of 4-5/8" of back spacing.
- Verify transmission type by measuring transmission oil pan. 4R70W measures approximately 13" x 13" square. Will not work on "long style" 13" x 24" E40D transmission equipped vehicles.

- New Super Crew Applications will only achieve 4" of lift due to the new torsion bar system. Maximum 33" x 12.50" tires on 16" x 8" wheels are recommended. 35" x 12.50" tires will require fender trimming.
- Vehicles equipped with manual transmissions will not be able to use lateral compression struts.
- This system utilizes the stock torsion bar to achieve the best ride quality. If after kit is installed, ride/handling seems too "soft", heavier Gross Vehicle Weight Rating (GVWR) bars can be installed. Contact your local Ford dealer for more details.

**\*\* The following special tools will be required for the proper removal and or installation of this kit.\*\***

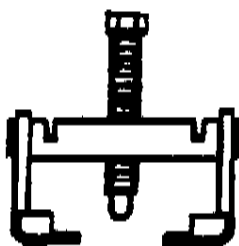

**Torsion Bar Tool  
# T95T-5310-A**

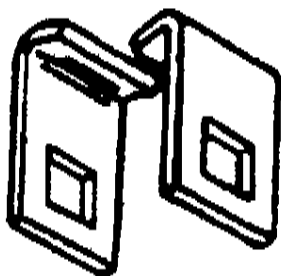

**Torsion Bar Tool  
Adapters  
#T96T05310-A**

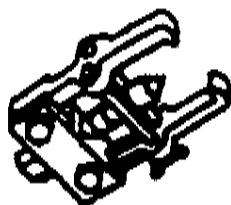

**Pitman Arm Puller  
# T64P-3509-F**

## **FRONT DISASSEMBLY**

1) **GETTING STARTED:** Measure ride height with vehicle supporting its own weight. Ride height is the measured distance from center of spindle to top of fender well (**Illustration 1**). Raise vehicle. If working without a shop hoist, put vehicle in gear, set emergency brake and block rear wheels, in front and behind tires. Loosen Lug nuts. Place floor jack under lower control arm's front crossmember and raise vehicle. Place safety jack stands under frame rails, behind front wheel wells and lower frame onto stands. Remove front wheels and tires.

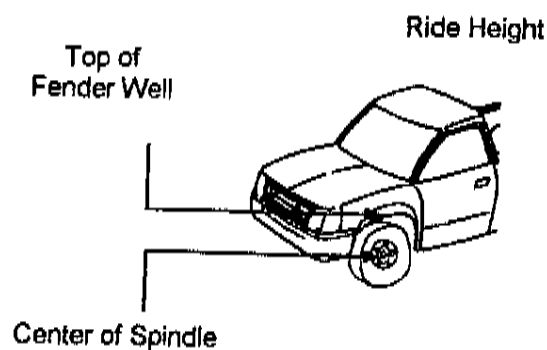

Illustration 1

**WARNING:** Be extremely careful when loading or unloading torsion bars. There is a tremendous amount of stored energy in the bars. Keep your hands and body clear of adjuster arm assembly and puller in case anything breaks.

2) Install Torsion Bar tool (T95T-5310-A) with Adapter Plates (T96T-5310-A) (**Illustration 2**). Tighten torsion bar tool until it touches torsion bar adjuster. Measure the depth of the adjuster bolt for replacement of torsion bar adjusters. Remove torsion bar adjuster bolt and nut. Remove torsion bar adjuster and repeat on opposite side.

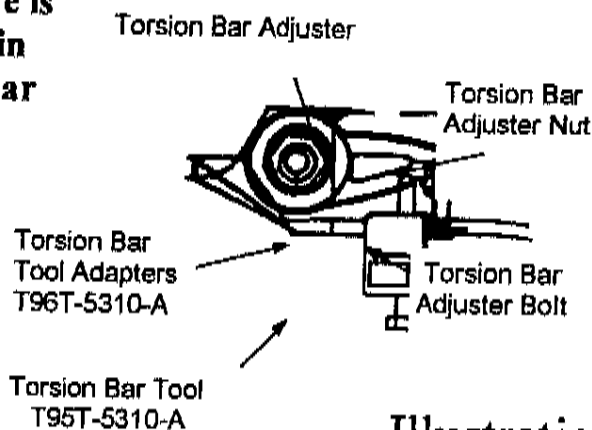

Illustration 2

**NOTE:** If vehicle is equipped with a 4-wheel anti-lock brake system, at this time disconnect the anti-lock sensor wire from brake line and reposition so not to damage ends.

3) Remove six bolts attaching torsion bar crossmember to frame (**Illustration 2**). Move crossmember back, one side at a time, while removing torsion bar. Remove assembly and set it aside.

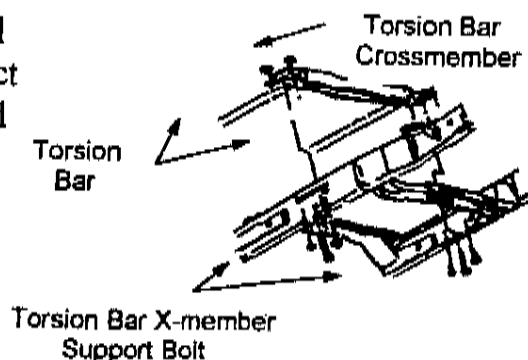

Illustration 3

4) Locate the (two) caliper bolts on front brake calipers (**Illustration 4**). Remove bolts and lift disc brake caliper off disc brake rotor. Position brake calipers aside. Use wire or plastic tie to support caliper. Do not let caliper hang by the brake lines.

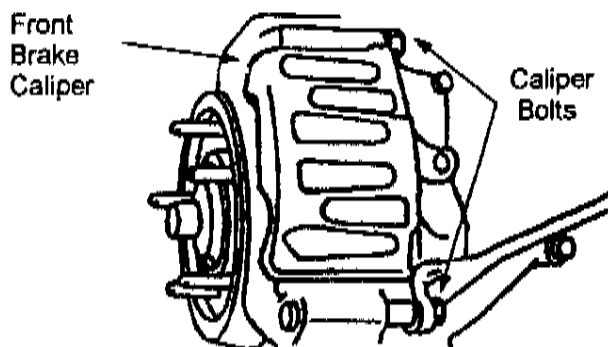

Illustration 4

5) See **Illustration 5** and loosen the three bearing assembly bolts located on back side of wheel hub.

6) Remove cotter pin, retainer and hub nut from front rotor (**Illustration 6**). Remove rotor and set aside. You will not be re-using the cotter pin. A new cotter pin will be needed for assembly. Remove front bearing assembly by removing the three bolts previously loosened.

**NOTE:** If your vehicle is equipped with the 4-wheel Anti-lock Brake system

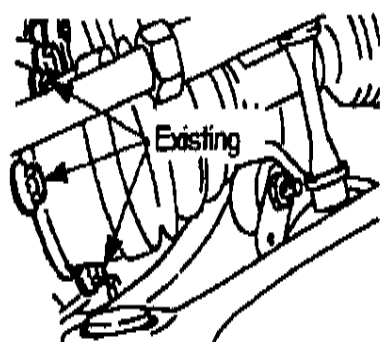

Illustration 5

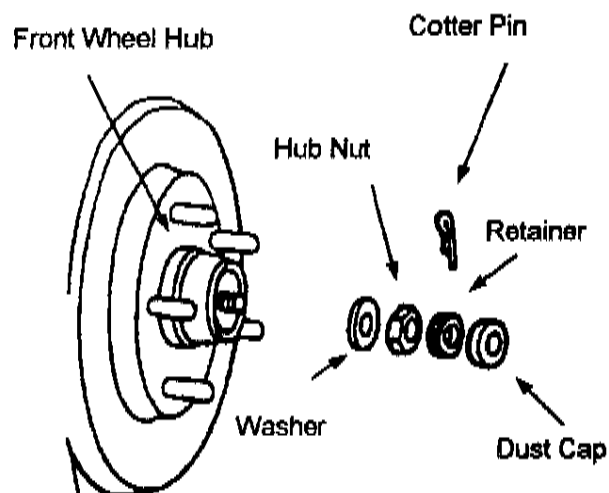

Illustration 6



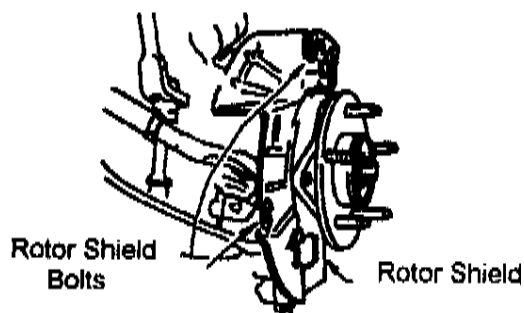

Illustration 7

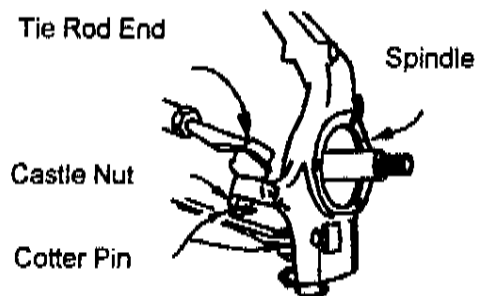

Illustration 8

remove the Disc Brake Rotor Shield at this time (**Illustration 7**). Disconnect anti-lock sensor wire from spindle and bearing assembly. Set aside so not to damage.

**7)** Locate Tie-Rod end castellated nut (**Illustration 8**). Remove the cotter pin and castellated nut. You will not be re-using the cotter pin. A new cotter pin will be needed for assembly. Using Pitman Arm Puller (T64P-3590-F) (**Illustration 9**) separate tie-rod end from front spindle.

**8)** Locate upper ball joint castellated nut (**Illustration 10**). Remove cotter pin and nut. You will not be re-using cotter pin. A new cotter pin will be needed for assembly. Attach Pitman Arm Puller (T64P-3590-F) as shown in

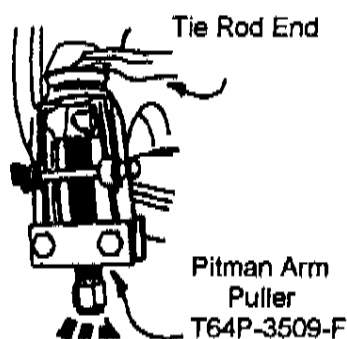

Illustration 9

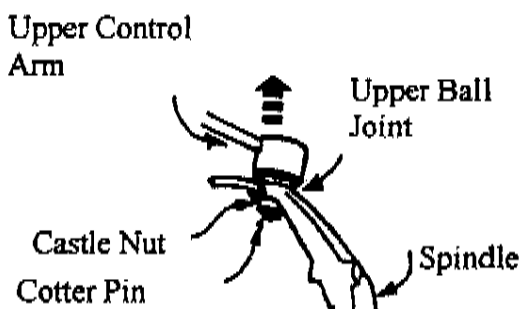

Illustration 10

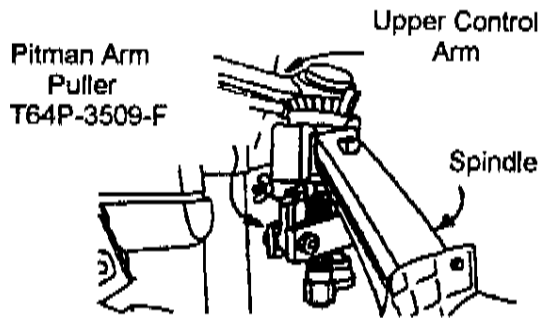

Illustration 11

**Illustration 11.** Separate the Front Spindle from upper suspension A-arm.

9) Remove sway bar link nut from Lower A-Arm (**Illustration 12**).

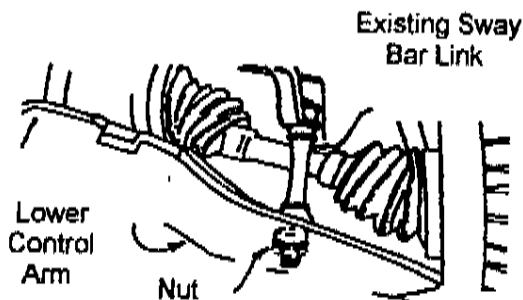

Illustration 12

10) Locate and remove front Shock Absorber lower mounting bolt and nut from lower A-arm.

11) Suspend front wheel drive shaft using a strap or wire, so not to bind.

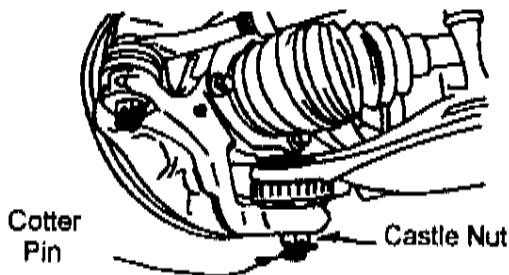

Illustration 13

12) Locate and remove lower ball joint cotter pin (**Illustration 13**). Using Pitman Arm Puller (T64P-3590-F), separate the front spindle from the lower A-arm. Remove the front spindle (**Illustration 14**).

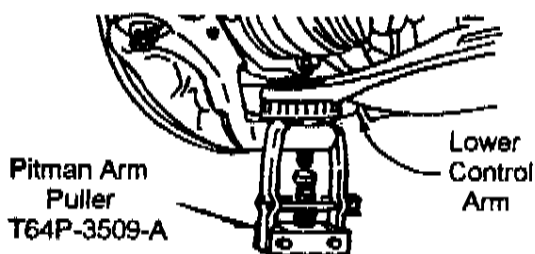

Illustration 14

13) Repeat steps 4 thru 12 on opposite side.

**14) Locate and disconnect vacuum line and front axle vent tube from front differential (Illustration 15). Use floor jack to support front drive axle.**

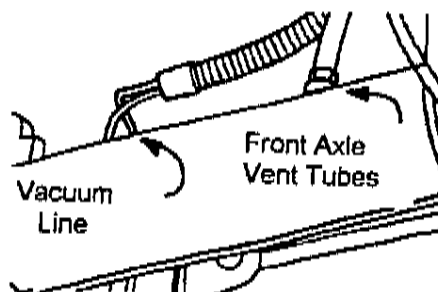

Illustration 15

**15) Locate existing differential crossmember (Illustration 16). Remove front bushing, hardware and four (4) differential crossmember bolts. Remove differential crossmember. You will not be re-using this item.**

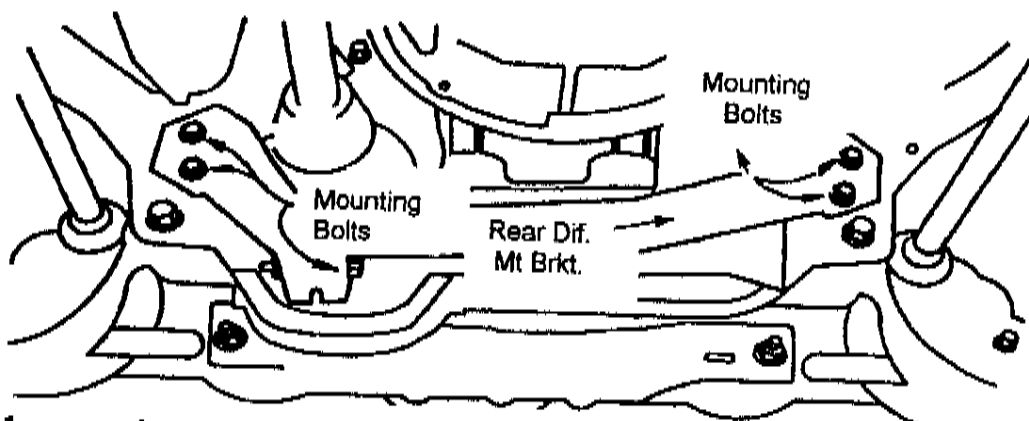
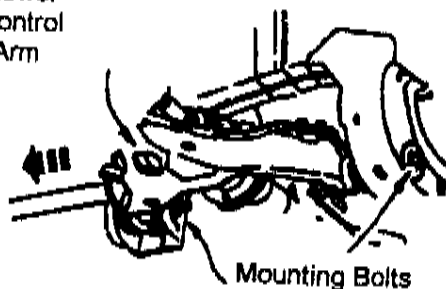

Illustration 16

**16) Locate the two (2) lower A-arm mounting areas (Illustration 17). Remove existing hardware and lower A-arm.**

Lower  
Control  
Arm



**18) Repeat steps 16 and 17 on opposite side.**

Illustration 17

**FRONT ASSEMBLY**

**NOTE:** If your vehicle is equipped with an O.E.M. skidplate, remove it at this time (Illustration 18).

1) Make sure Front Differential is well supported, then remove existing hardware from both passenger and driver side differential mounting areas. Carefully lower differential enough to install Differential Drop Bracket (20-52097-5) on passenger side using the 1/2" hardware provided (Illustration 19). Install, but do not tighten.

Skidplate Bolts

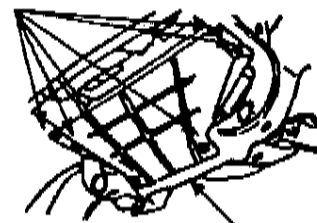

Existing Skidplate

Illustration 18

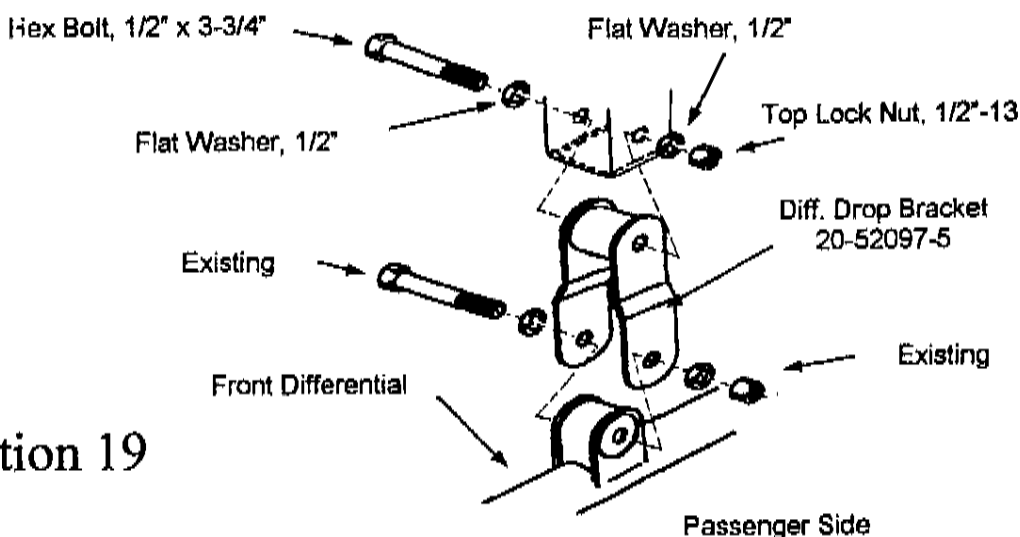
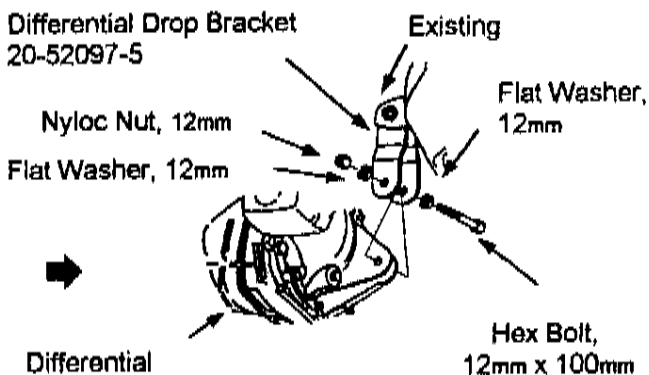

Illustration 19



2) Install Front Driver side Differential Drop Bracket (20-52097-5) using 12mm hardware provided (Illustration 19). Make sure the bolt head is facing the passenger outboard side of vehicle. Do not tighten.

Illustration 20

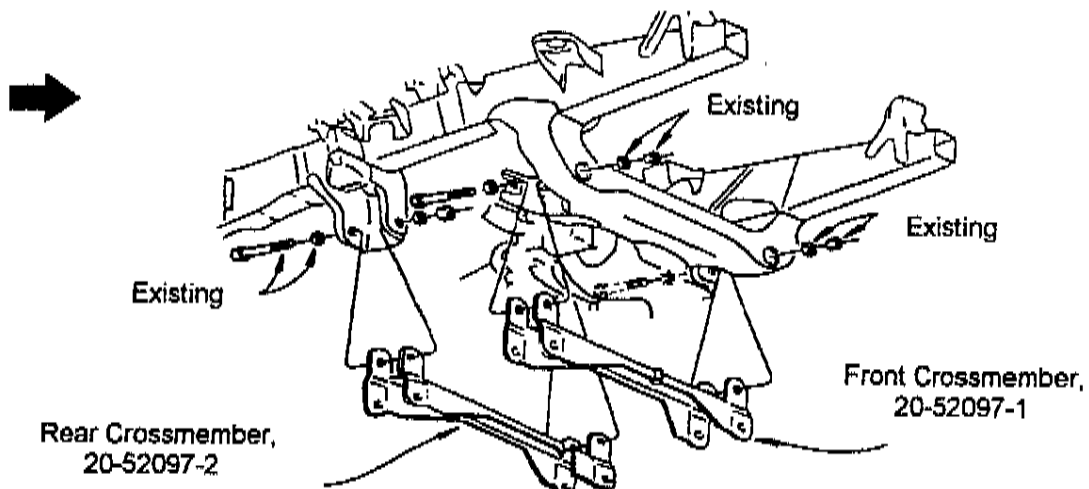

Illustration 21

**3) Install Rear Crossmember (20-52097-2) into original A-arm rear mounting locations (Illustration 21). Make sure differential mount fits inside mounting tabs on rear crossmember (Illustration 22). Use existing hardware previously removed and make sure the bolt heads are facing towards rear of vehicle. Do not tighten.**

**4) Install Front Crossmember (20-52097-1) into original front A-arm mounting locations (Illustration 21). Unfasten and slide driver side lower differential mounting hardware back enough to align differential mount bracket to support**

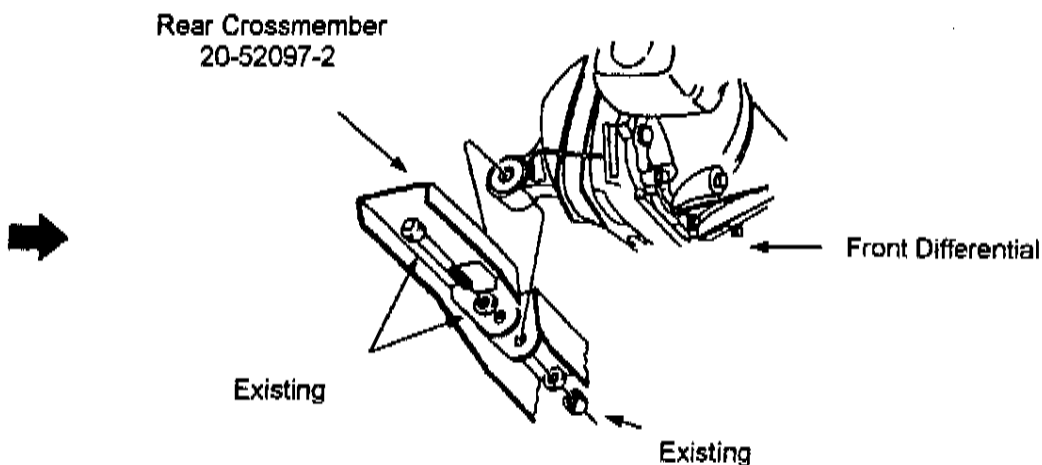
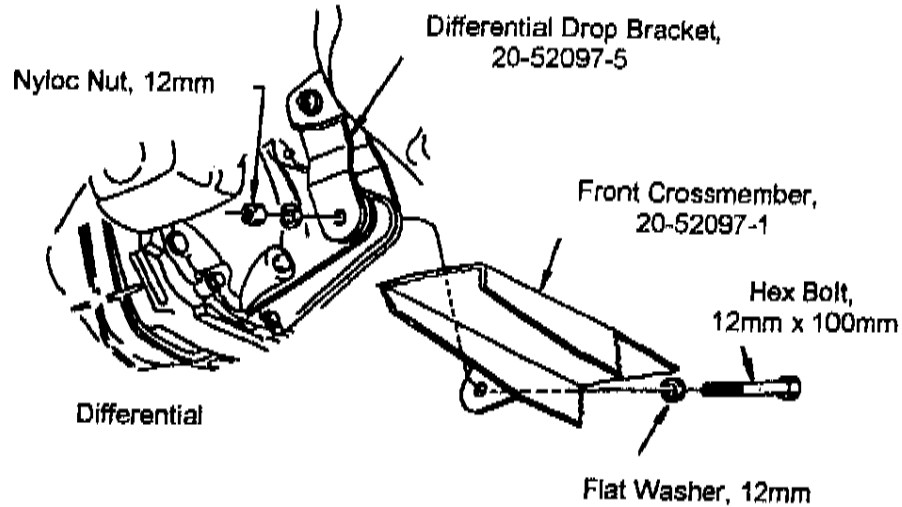

Illustration 22



### Illustration 23

tab on crossmember (**Illustration 23**). Fasten front crossmember using existing hardware previously removed. Make sure bolt heads are facing to the front of vehicle. Do not tighten.

5) Install existing Lower A-arms into the new front and rear crossmember mounting locations using the 5/8" hardware provided.

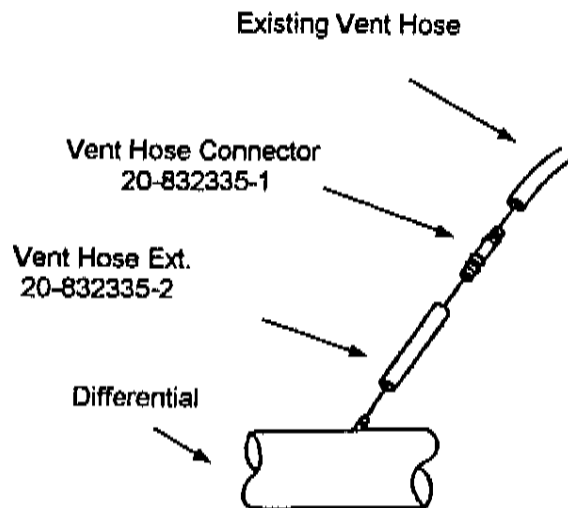

### Illustration 24

6) Install new Vent Hose Connector (20-832335-1) into existing vent hose. Install Vent Hose Extension (20-832335-2) into Connector and Axle tube (**Illustration 24**).

7) Torque existing crossmember mounting nuts to 121-147 ft. lbs. Torque existing differential mounting nuts to 56-76 ft. lbs. Torque 12mm and 1/2" differential mount nut to 110 ft. lbs.

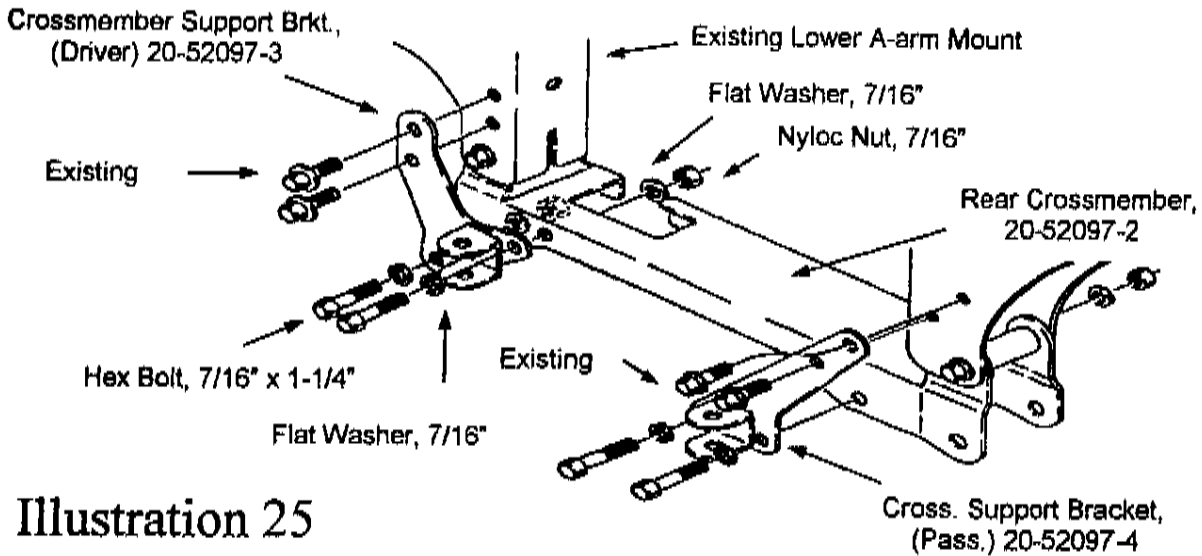

Illustration 25

**8) Referring to Illustration 25, install Crossmember Support Brackets (20-52097-3 Drvr.) and (20-52097-4 Pass.). Fasten upper mounts of bracket to existing rear crossmember mounting locations using hardware previously removed. Fasten lower mounts to rear crossmember using 7/16" hardware provided. Do not tighten at this time.**

**9) Install Front Crossmember Spacer (11-13737) using 1/2" hardware and load washer (Illustration 26). Make sure bolt head is on bottom. Torque nut to 76 ft. lbs.**

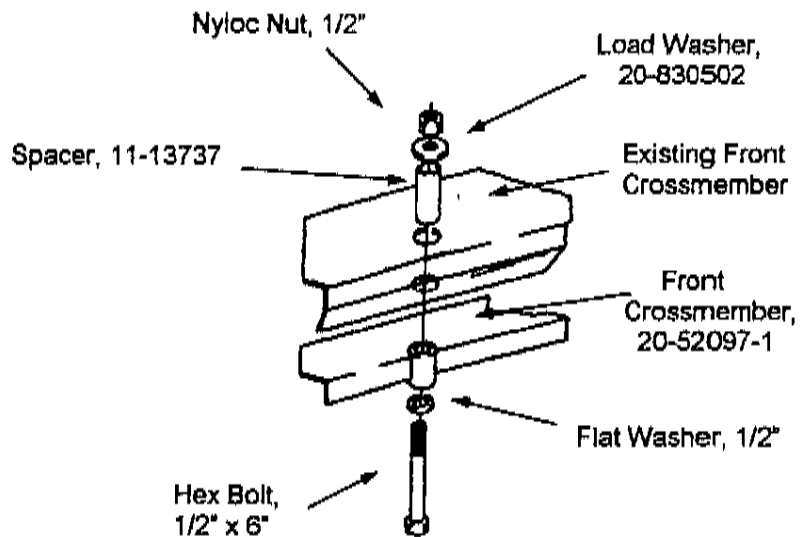
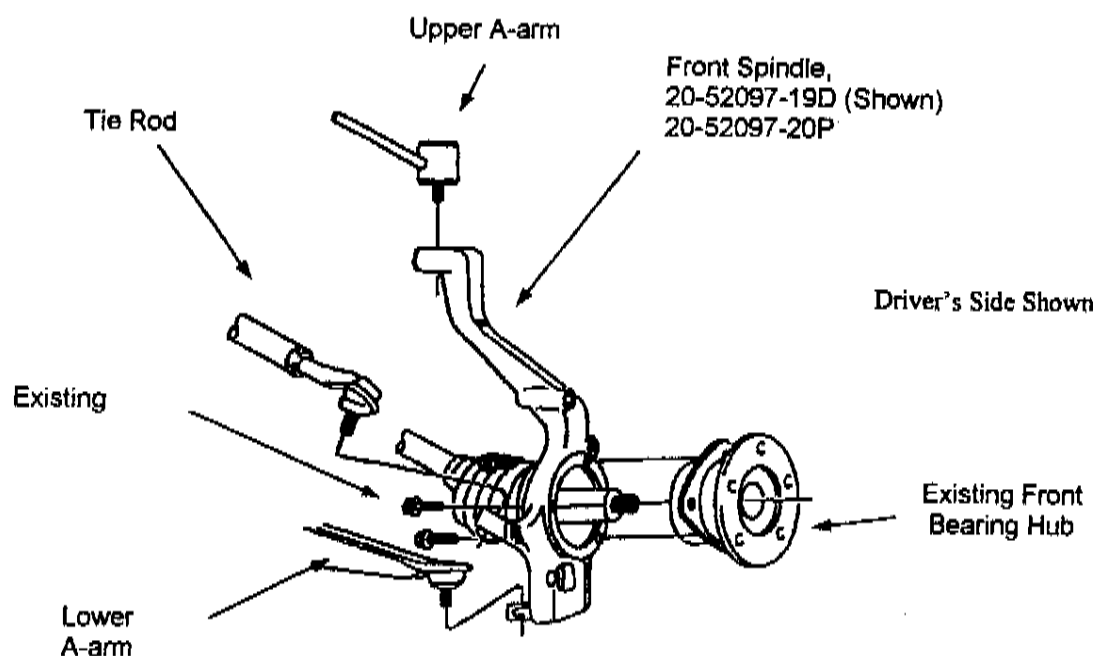

Illustration 26

**10) Refer to Illustration 27. Remove seals from old spindles and install in new spindles. Support Lower A-arms. Position and attach new front spindle (20-52097-19D Drvr) and (20-52097-20P Pass.) to upper ball joint. Torque nut to 55-77 ft. lbs. Attach ball joint on lower A-arm to Front Spindle. Torque to 83-112 ft. lbs. Apply new cotter pins at these locations. Install axle bearing assembly, apply Loctite and torque the three bolts to 110-148 ft. lbs. Do not tighten hub nut at this time.**

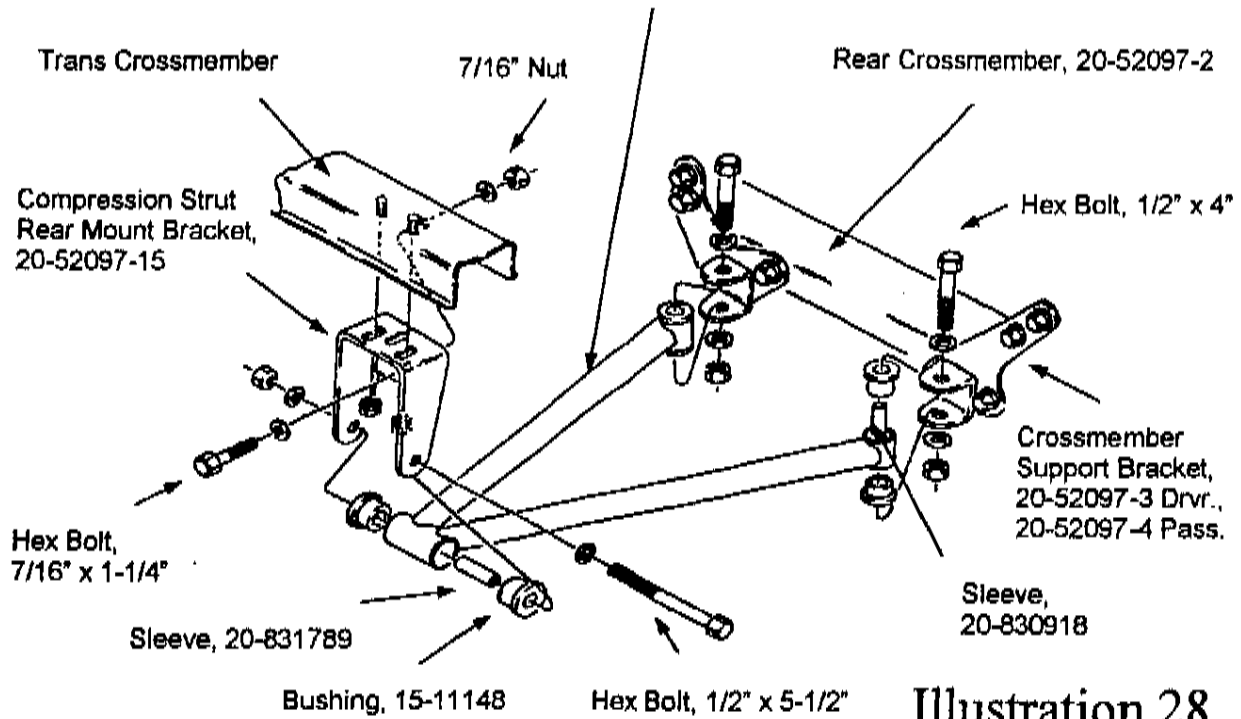

**Illustration 27**

**NOTE:** Compression strut assembly will not work on vehicles with a manual transmission, due to transmission's crossmember location.

**11) Remove rear transmission mount hardware from trans crossmember. Position Compression Strut Bracket (20-52097-15) on trans crossmember and use as guide to mark the mount location where trans crossmember is to be drilled. Remove Bracket and drill a 1/2" diameter hole in the marked area on crossmember. Remove Driver Side Crossmember Support Bracket (20-52097-3). Install Compression strut (20-52097-16) as shown in**





**Illustration 28**

**Illustration 28.** Install crossmember support bracket to crossmember and existing mount. Tighten assembly. Torque existing trans crossmemembr nuts to 64-81 ft. lbs. Torque 1/2" nuts to 76 ft. lbs. Torque 7/16" nut to 51 ft. lbs. Torque existing crossmember support bolts to 56-76 ft. lbs.

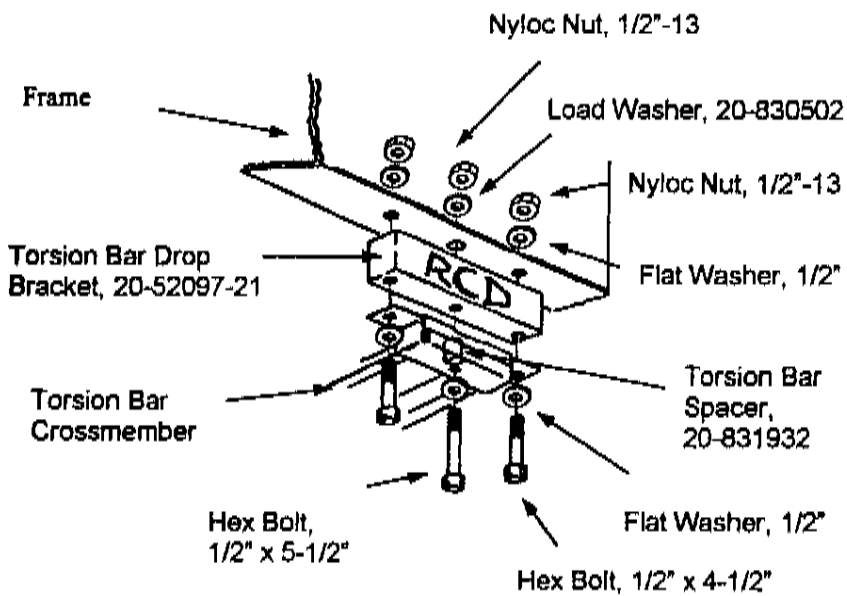

**Illustration 29**

12) Locate existing torsion bar crossmember mount bracket. Remove nut clip and rubber mounting bushing. Drill center mounting hole on bracket to 9/16" diameter. Be sure to turn crossmember over (inside the bracket) before mounting. Slide the bracket onto torsion bar crossmember, then insert Torsion Bar Spacer (20-831932) as shown in **Illustration 29**. Loosely fasten, using Torsion Bar

Drop Bracket (20-52097-21) and hardware provided. Insert existing torsion bars, then torque hardware to specification chart on back page. Set torsion bar adjuster screw to depth previously measured at the beginning.

**NOTE:** If vehicle is equipped with 4-wheel anti-lock brake system. Install wire and sensor to spindle and bearing assembly at this time.

13) Install Front disc brake rotor shield using existing hardware. Do not over tighten.

14) Attach tie-rod to Front Spindle and make sure tapers are seated. Torque existing nuts to 57-77 ft. lbs. apply new cotter pins at these locations.

15) Locate and remove existing bumpstops on lower A-arm. Fasten the existing bumpstops to Bumpstop Brackets (20-52097-17) as shown in **Illustration 30**. Install bumpstop to Bracket using existing hardware. Install Bracket to A-arm using 3/8" Hex Bolt, Flat Washers and nyloc Nut provided. Torque nuts to 32 ft. lbs.

16) Install new longer Front Shock Absorbers (BE5-6138). Torque according to specifications chart.

17) Install front disc rotor but do not tighten hub at this time.

18) Locate and remove brake line mounting bolt on vehicle frame, both driver and passenger side. Move the brake line away from frame and attach Brake Line Extension Bracket (20-832595) to the original

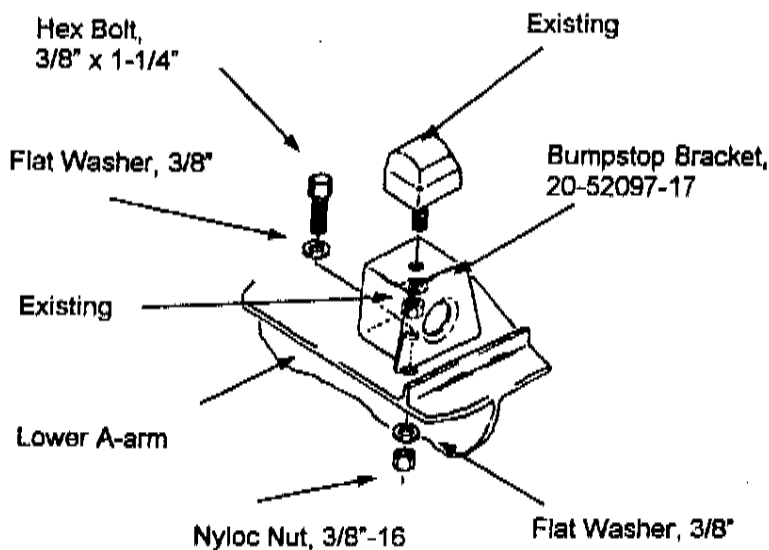

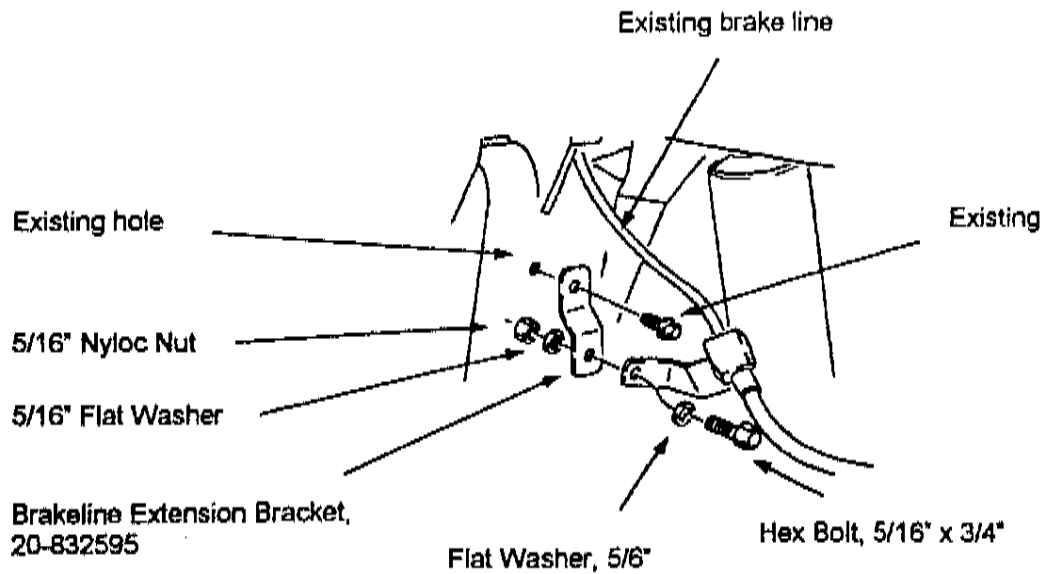

Illustration 31

mounting location using existing hardware (**Illustration 31**). Do not tighten at this time. Carefully obtain enough excess steel line by straightening and bending until brake line can be attached to the Brake Line Extension Bracket previously installed. Secure using the 5/16" hardware provided. Install the brake calipers to the front spindles using existing hardware. Torque to 21-26 ft. lbs. Cycle steering lock-to-lock and check for adequate brake line clearance. Tighten Brake Line Extension hardware when clearance is obtained.

**NOTE:** Non front ABS vehicles will have a pair of steel lines that must be relocated. Be very careful not to kink the steel lines during the previous procedure.

**NOTE:** If vehicle is equipped with 4-wheel anti-lock brake system reconnect the sensor at this time.

20) Install front wheels. Lower vehicle and torque axle hub nut to 187-254 ft. lbs.

21) With vehicle supporting its own weight, install sway bar using Sway Bar Link (20-832803) using hardware provided (**Illustration 32**). Torque Button Head bolt to 66 ft. lbs.

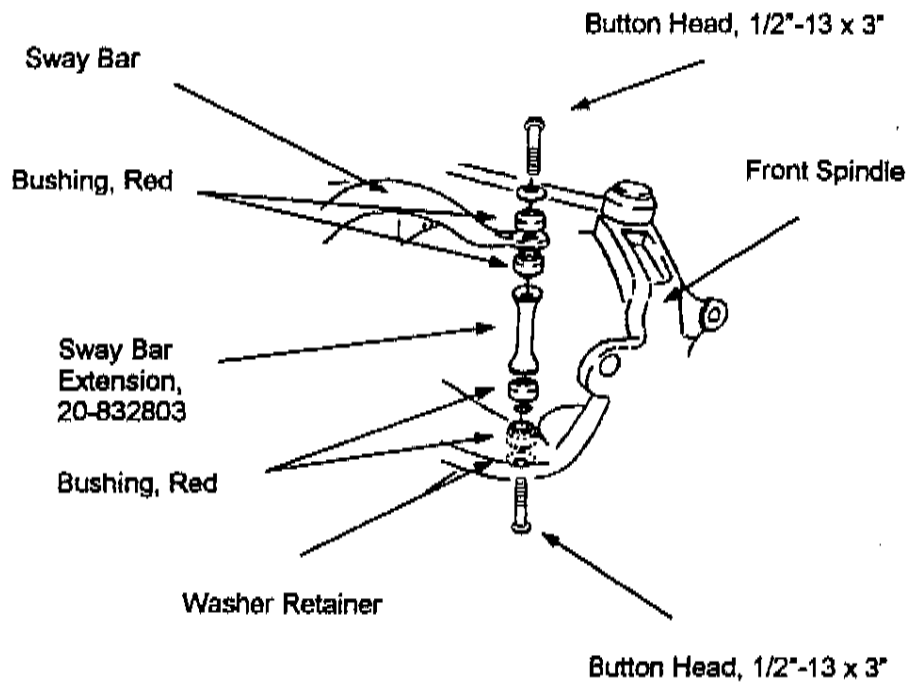

Illustration 32

## **REAR INSTALLATION**

1) Raise the vehicle. If working without a shop hoist support vehicle with suitable safety stands. To do this put vehicle in gear, block front wheels, both in front and behind tires, then disengage emergency brake. Place floor jack underneath rear axle and raise vehicle. Place suitable safety stands under frame to support vehicle and lower vehicle onto safety stands.

2) With a floor jack, raise the rear axle just enough to relieve tension on the shock absorbers and remove shocks.

3) Disconnect the axle vent hose from the axle housing.

4) Make sure the axle is well supported and remove axle U-bolts and hardware. Next remove the spring eye bolts and/or shackles and remove the springs from the vehicle.

**CAUTION:** Do not allow axle to hang by any hoses or cables.

5) Use C-clamps or a large bench vise to hold the spring assembly securely Together (**Illustration 33**).

6) If applicable, remove any spring leaf alignment clamps. Remove the spring center bolt. A hammer and drift punch may be necessary to drive pin out.

7) Carefully remove C-clamps or open vise and lay unassembled spring aside.

**NOTE:** Add-a-leaf (13-70026-1) will be placed in the spring assembly

### Illustration 33

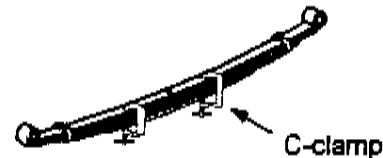

Secure spring assembly together with suitable C-clamps. Remove spring center bolt. Carefully remove C-clamps and insert Add-a-Leaf.

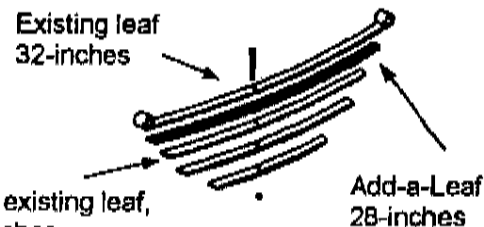

Position Add-a-Leaf in spring pack progressively according to length. EX: Two existing leaves are 32" & 25", place the 28" Add-a-Leaf between existing leaves.



Do not install Add-a-Leaf below a helper spring.



Install C-clamps then Center Bolt. Do not attempt to pull springs together with Center Bolt.

progressively according to length. For example, if existing leave is 32" long and next is 25" long, and the new Add-a-leaf is 28" long, place Add-a-leaf between existing leaves.

**NOTE:** If equipped, do not install your Add-A-Leaf spring below the helper spring assembly. Factory helper springs are flat or nearly flat leaves installed at the bottom of the leaf pack.

8) Apply a small amount of grease to both ends of the Add-A-Leaf. Assemble leaf springs using C-clamps with Add-A-Leaf in place.

9) Insert new center pin (13-90750) and nut. Torque nut to 20 ft. lbs.

**CAUTION:** Do not try to compress the spring with center pin.

10) Carefully remove C-clamps.

11) Install completed spring assemblies into their respective chassis mounts. Install using provided U-bolts and hardware. Torque U-bolt nuts to 85-100 ft. lbs.

12) Connect axle vent hose.

13) Install the longer Rear Shock Absorbers (BE5-6093) and torque according to the specification chart on last page.

14) Install wheels and lower vehicle to ground.

15) Once vehicle is supporting it's own weight, adjust ride height.

**NOTE:** To attain ride height add the lift kit height to the original ride height measurement previously taken during "GETTING STARTED" in Front Disassembly. Example: Original ride height of 21" plus 5" for lift kit height, equals 26" for proper ride height measurement. On this example vehicle adjust torsion bar to achieve ride height of 26." Manually bounce the front and rear of vehicle to pre-set the bar and springs. Then, evenly adjust the torsion bar bolts until the front of the vehicle spindle-to-top of fender well measurement achieves proper ride height.

**NOTE:** Each torsion bar may require slightly different adjustment to level vehicle side to side.

16) Once ride height has been achieved torque front Sway Bar Extension Button Head bolts to 66 ft. lbs.

## **SOME FINAL NOTES**

- After installation is complete, double check that all nuts and bolts are tight. Refer to the chart on the last page for torque specifications. (Do not retighten nuts and bolts where Loctite compound was applied).
- If new tires are installed that are more than 10% taller than original tires, the speedometer must be recalibrated for the anti-lock brake system (if applicable) to function properly. Contact an authorized Ford dealer for details on recalibration.
- Bleed Brake System according to O.E. specifications (only if hose's were changed). Use Ford approved brake fluid only.
- With vehicle on floor, cycle steering lock to lock and inspect steering, suspension and driveline systems for proper operation, tightness and adequate clearance. Recheck brake/hose fitting for leaks. Be sure all hoses are long enough.
- Have headlights readjusted to proper setting.
- Realign front end to factory specifications. Be sure vehicle is at desire ride height prior to realignment.

## **TORQUE SPECIFICATIONS** (Grade 8 & Class 10.9)

5/16" NUTS	20 ft. lbs.	M6	9 ft. lbs.
3/8" NUTS	35 ft. lbs.	M8	23 ft. lbs.
7/16" NUTS	60 ft. lbs.	M10	45 ft. lbs.
1/2" NUTS	90 ft. lbs.	M12	75 ft. lbs.
9/16" NUTS	160 ft. lbs.	M14	120 ft. lbs.
5/8" NUTS	175 ft. lbs.	M16	165 ft. lbs.

Front axle hub nut	187-254 ft. lbs.
Font lower arm ball joint castellated nut	83-112 ft. lbs.
Front lug nuts	83-112 ft lbs.
Front shock absorber lower bolt	56-76 ft. lbs.
Front suspension lower arm nuts	121-147 ft. lbs.
Front upper arm ball joint castellated nut	56-76 ft. lbs.
Front stabilizer bar link nuts	16-21 ft. lbs.
Torsion bar crossmember support bolt	29-40 ft. lbs.
Torsion bar crossmember support nut	39-53 ft. lbs.
Tie rod end castellated nut	56-76 ft. lbs.