



3/26/14

**2011-2014 CHEVY 2500HD
6" SUSPENSION SYSTEM
P/N: 10-41811**

INSTALLATION INSTRUCTIONS

NOTE: Each lift kit, and options to lift kits, are packaged separately. Therefore installation procedures are covered in separate instructions. Familiarize yourself with each specific set of instructions before beginning.

PART LIST

ITEM	DESCRIPTION	QTY.	ILLUS.
Box 1 of 7			
20-51811-1	Front Crossmember	1	15, 17, 18
20-51811-2	Rear Crossmember	1	13, 14, 17,18, 23
Box 2 of 7			
20-51811-5D	Steering Knuckle - Driver Side	1	
Box 3 of 7			
20-51811-17	Compression Strut	2	23
20-51811-18	Compression Strut Bracket	2	17, 23
20-51099-22	Strut Mount Bracket	2	23
20-70268	Hardware Pack (Compression Strut)		
13-20069-Z	Hex Bolt, 1/2"-13 x 4"	4	23
13-30034-Z	Flat Washer, 1/2"	8	23
13-10038-Z	Nyloc Nut, 1/2"-13	4	23
20-830918	3/4" OD x .095w x 2-3/4" Sleeve	4	23
15-11148	Bushing, Red	4	23
20-68526	Hardware Pack (Strut Mount)		
13-21677-B	Self Tapping Bolt, 3/8"-16 x 1"	4	23
Box 4 of 7			
20-51811-3	Driver Bumpstop Bracket	1	16
20-51811-4	Passenger Bumpstop Bracket	1	
20-51811-7	Driver Diff Drop Bracket	1	12
20-51811-8	Passenger Diff Drop Bracket	1	12
20-51811-9	Skid Plate	1	18
20-51811-11	Driver Torsion Drop Bracket	1	24
20-51811-12	Passenger Torsion Drop Bracket	1	
20-51811-16	Wheel Spacer	1	
20-72371	Hardware Pack (Crossmember)		
13-24173-Z	Hex Bolt, 18MM-2.5 x 120MM	2	17
13-24186-Z	Hex Bolt, 18MM-2.5 x 140MM	2	17
13-30876-Z	Flat Washer, 18MM	8	17
13-10969-Z	Nyloc Nut, 18MM-2.5	4	17

20-72384	Hardware Pack (Skid Plate)		
13-22938-Z	Hex Bolt, 3/8"-16 x 1-1/4"	4	18
13-30408-Z	Flat Washer, 3/8"	4	18
13-30151-Z	Lock Washer, 3/8"	4	18
20-72397	Hardware Pack (Diff Drops)		
13-21456-Z	Hex Bolt, 1/2"-13 x 1-1/2"	2	12
13-30382-Z	Flat Washer, 1/2"	4	12
13-10514-Z	Top Lock Nut, 1/2"-13	2	12
13-24199-Z	Hex Bolt, 12MM-1.75 x 30MM	3	12
13-30546-Z	Flat Washer, 12MM	6	12
13-10592-Z	Flange Nut, 12MM-1.75	3	12
20-72410	Hardware Pack (Bumpstops)		
13-23978-Z	Self Drilling Screw, 1/4-14 x 1"	4	16
20-72423	Hardware Pack (Drive Axle Spacers)		
20-51811-20	Drive Axle Spacer	2	19
13-24212-Z	Hex Bolt, 10MM-1.5 x 45MM	16	19
13-30642-Z	Flat Washer, 10MM	16	19
20-72436	Hardware Pack (Sway Bar Extension)		
20-835605	Sway Bar Extension, 11"	2	22
13-22743-Z	Button Head, 1/2" – 13 x 3" Lg.	2	22
13-30694-Z	Washer, Bushing Retainer 1-1/4"	6	22
13-10878-Z	Nyloc Nut, 1/2"-20	2	22
15-11616	Inner Bushing, Sway Bar Link	2	22
15-11629	Outer Bushing, Sway Bar Link	2	22
15-11746	Bushing, Sway Bar Flex Joint	4	22
20-72449	Hardware Pack (Brake Line & Front Skid Plate)		
20-51811-10	Front Brake Line Bracket	2	20
13-20536-Z	Hex Bolt, 5/16"-18 x 1"	4	20, 21
13-30187-Z	Flat Washer, 5/16"	6	20, 21
13-10155-Z	Nyloc Nut, 5/16"-18	4	20, 21
13-31032-Z	Fender Washer, 5/16"	2	21
20-72462	Hardware Pack (Torsion Bar Drops)		
13-23107-Z	Hex Bolt, 9/16"-12 x 4"	2	24
13-30395-Z	Flat Washer, 9/16"	4	24
13-10397-Z	Top Lock Nut, 9/16"-12	2	24
13-21352-Z	Hex Bolt, 1/4"-20 x 1"	2	24
13-30195-Z	Flat Washer, 1/4"	4	24
13-10161-Z	Nyloc Nut, 1/4"-20	2	24

Box 5 of 7

20-833349-1D	Driver Rear Block, 4" W-Arm 3/4" Hole	1	26
20-833349-2P	Passenger Rear Block, 4" W-Arm 3/4" Hole	1	
13-91556	U-Bolt, 3/4" x 3.145" x 15-1/4"	4	26
20-72475	Hardware Pack (U-Bolts)		
13-11203	High Nut, 3/4"-16 Plain	8	26
13-31019	Flat Washer, 3/4" Plain	8	26
20-72488	Hardware Pack (Rear Brake)		
20-51811-13	Rear Speed Sensor Bracket	2	28
20-51811-14	Park Brake Cable Bracket	1	27
20-51811-15	Rear Brake Line Bracket	1	25
13-20536-Z	Hex Bolt, 5/16"-18 x 1"	4	25, 27, 28
13-30187-Z	Flat Washer, 5/16"	6	25, 27, 28
13-10155-Z	Nyloc Nut, 5/16"-18	4	25, 27, 28

Box 6 of 7

20-51811-6P	Steering Knuckle—Passenger Side	1	
-------------	---------------------------------	---	--

Box 7 of 7

59-71811-1	Front Shock	2	
50-BE5-6134-T5	Rear Shock	2	

INTRODUCTION

Installation by a professional mechanic is recommended. Use of the appropriate tools, a GM service manual, and a shop hoist can greatly reduce installation time.

Prior to installation, carefully inspect the vehicle's steering and drive train systems, paying close attention to the tie-rod ends, rack & pinion unit, ball joints and wheel bearing preload. Also check steering-to-frame and suspension-to-frame attachment points for stress cracks. The overall vehicle must be in excellent working condition; repair or replace worn parts.

Read instructions carefully and study illustrations before attempting installation. **RCD Suspension** is not responsible for damage, failure or injury resulting from improper installation or parts substitution of this kit.

Check parts and hardware against the parts list to assure that your kit is complete. Report any shortages to RCD Suspension at (1-619-588-4723). The parts and hardware supplied are of high-grade material and must not be replaced by inferior parts or failure may result. Do not begin installation if parts are missing.

Separate parts according to the areas they will be used. Placing the hardware with brackets before you begin will save installation time.

This kit is supplied as a bolt-on assembly. Do not weld anything to the components and do not weld the components to the vehicle.

All components in this kit come with a protective coating. Do not plate (i.e. chrome, cadmium, zinc etc.) or otherwise alter the finish in any way. This could decrease the structural strength of the components.

Secure and properly block vehicle prior to beginning installation.

Always wear safety glasses when using power tools.

Foot-Pound torque readings are listed on the Torque Specifications chart at the end of the instructions unless specifically stated in an instruction. **DO NOT USE AN IMPACT WRENCH TO TIGHTEN ANY OF THE BOLTS.**

PLEASE NOTE

WARNING: DO NOT USE WHEEL SPACERS

Front-end realignment is necessary.

Speedometer recalibration is necessary if larger tires (10% more than stock diameter) are installed.

Brake system will need to be bled by a professional brake technician.

System is designed to accommodate up to a 35" x 12.50" tire. Wheel sizes of 17" x 9" with a maximum of 5-1/2" backspacing, 18" x 9" with a maximum of 5-3/4" backspacing and 20" x 9" with a maximum of 6" backspacing.

Special tools are required for safe removal and installation of the ball joints, tie-rods and torsion bars. These tools can be purchased from your GM Dealer.

Torsion Bar Unloading Tool # J 36202
Steering Linkage Puller #J 24319-B
Ball Joint Separator Tool #J 43631

Note: Wheel Spacer (20-51811-16) should be kept with vehicle for use with factory spare wheel only.

Front Installation Instructions

1. GETTING STARTED: Measure ride height with vehicle supporting its own weight. Ride height is the measured distance from the center of spindle to top of the fender well (**Illustration 1**). Raise the vehicle. If working without a shop hoist, put vehicle in gear, set emergency brake and block rear wheels, in front and behind tires. Loosen front wheel lug nuts. Place floor jack under the lower control arm's front crossmember and raise vehicle. Place safety jack stands under frame rails, behind front wheel wells, and lower the frame onto the stands. Remove front wheels.

Illustration 1

Ride Height Measurement

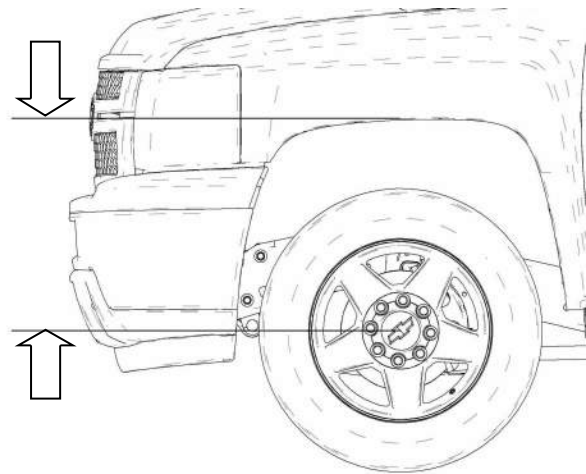

2. Measure and record Torsion Bar Adjusting Screw depth for replacement of Torsion Adjuster Arm. Remove torsion bar adjusting screw. Apply a small amount of lubricating grease to J 36202 puller threads and puller shaft-to-adjuster arm contact point. Position puller over the adjuster arm and load adjuster arm until adjuster nut can be removed from the crossmember (**Illustration 2**). With bar unloaded, slide it further forward into the lower control arm. If bar seems lodged, use a hammer to punch through hole in the back of crossmember. When bar shifts forward, the adjuster arm will fall.

Illustration 2

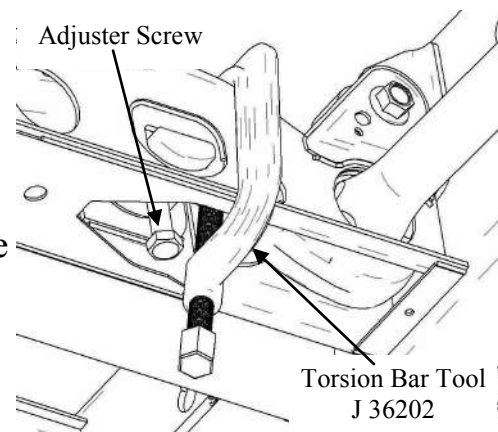

CAUTION: Be extremely careful when loading or unloading the torsion bars. There is tremendous amount of stored energy in the bars. Keep your hands and body clear of the adjuster arm assembly and puller tool in case anything breaks.

3. Remove torsion bar crossmember by removing the two bolts that connect crossmember to frame. **(Illustration 3)**. With crossmember out of the way, the torsion bars can be dislodged from lower control arms and removed. Mark or separate the bars, since they must be reinstalled on the same side they were removed from.

Illustration 3

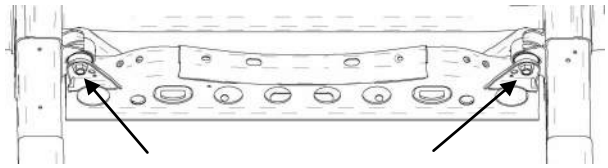

4. Remove front shock absorbers.
5. Remove anti-sway bar links, which connect bar body to lower control arms **(Illustration 4)**.
6. Mark differential flange and the drive axle flange for installation reference.

Illustration 4

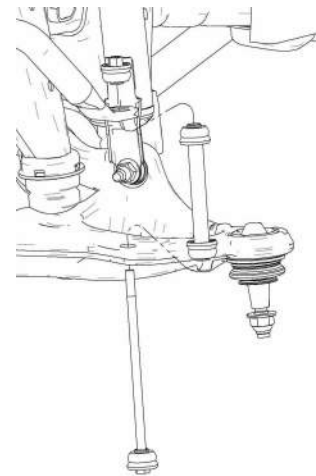

7. Beginning on driver side, remove nut and washer from hub **(Illustration 5)**. Remove eight bolts that fasten drive axle to differential. Pull drive axle out of hub through the lower control arm.

Illustration 5

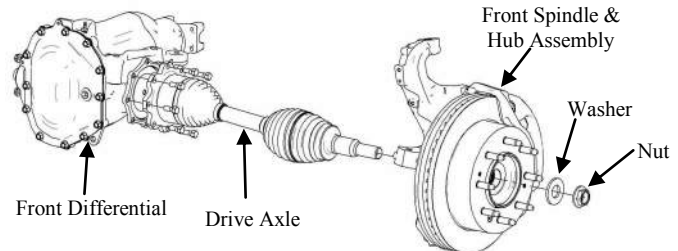

NOTE: Be careful not to damage the drive axle boots.

8. Locate then disconnect brake hose bracket at knuckle. Locate the two caliper mounting bracket bolts attaching the brake caliper to rear of front knuckle. Remove the bolts then remove caliper and bracket as an assembly. Use a length of wire to secure caliper assembly out of the way and to prevent damage to brake lines.

CAUTION: Do not allow brake caliper to hang by the brake hose.

9. Remove torx bolt attaching brake rotor and remove rotor.
10. Disconnect wheel speed sensor at hub and move out of way.
11. Locate tie rod end and remove the nut. Attach Universal Steering Link Puller (J 24319) and separate tie rod end from front spindle. **(Illustration 6)**.
12. Locate front lower ball joint and remove nut from ball joint. Using Ball Joint Separator Tool (J 43631) apply pressure on tool until ball joint breaks loose from lower part of the front spindle. **(Illustration 6)**.

13. Locate front upper ball joint. Remove nut from ball joint. Using Ball Joint Separator Tool (J 43631) apply pressure on tool until ball joint breaks loose from upper part of the front spindle. **(Illustration 6).**

Illustration 6

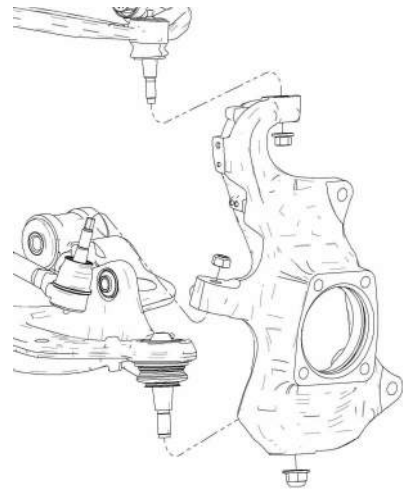

14. Remove front spindle with the hub and bearing assembly attached, set aside. **(Illustration 6).**

15. Remove lower control arm pivot bolts and remove lower control arm **(Illustration 7).**

16. Repeat steps 7 through 14 on opposite side.

17. Remove front plastic skid plate and differential skid plate, if vehicle is so equipped.

Illustration 7

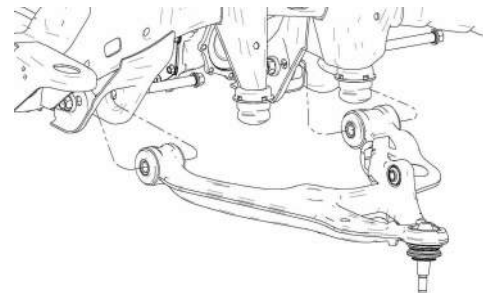

18. Locate front drive shaft U-joint to differential yoke. Place an index mark for installation reference on both the drive shaft U-joint and differential yoke. Remove hardware from the yoke and slide shaft rearward to disengage. **(Illustration 8).** Tape bearing cap assemblies and secure shaft out of the way. Disconnect the electrical connector and vent hose from differential assembly.

Illustration 8

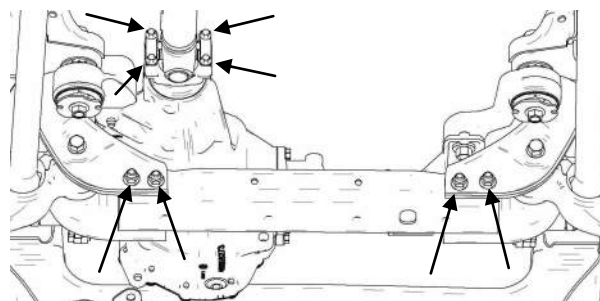

19. Remove the four bolts attaching crossmember that runs under differential, and remove crossmember. **(Illustration 8).**

20. Support front differential assembly with a floor jack. Remove the three bolts on the driver side and the two nuts on the passenger side **(Illustration 9).** Slowly remove the differential assembly from vehicle, and lower it to the floor.

Illustration 9

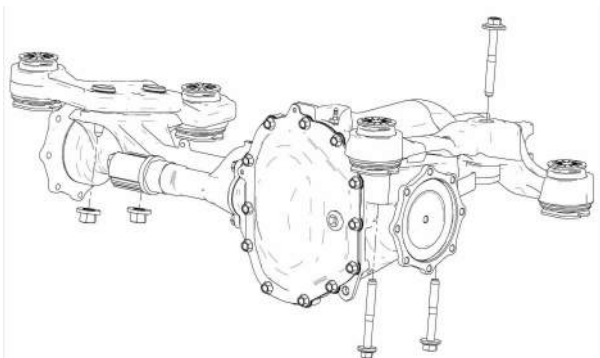

Illustration 10

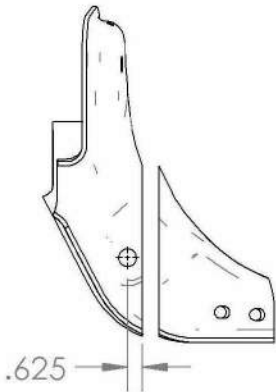
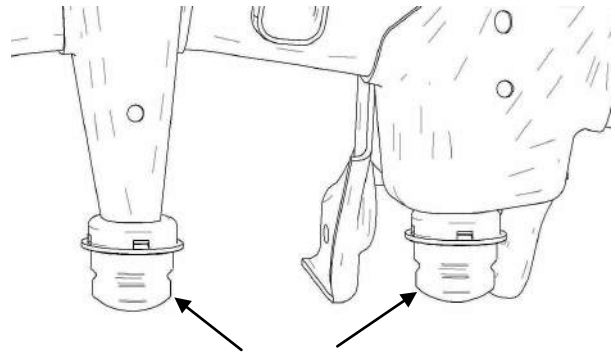

Illustration 11



21. Mark and then trim frame at driver rear control arm mounting location. **(Illustration 10)**. Clean sharp edges. Paint exposed metal.

22. Remove the two bumpstops located on either side by prying out of pockets and set aside. **(Illustration 11)**.

23. Install Driver Diff Bracket (20-51811-7) to frame using Existing bolt and 12mm hardware provided. Install Passenger Diff Bracket (20-51811-8) to frame using Existing Nuts. Do Not Tighten. **(Illustration 12)**.

24. Raise differential into place and attach to Diff Brackets using existing bolts and 12mm hardware provided on driver side and 1/2" hardware provided on passenger side. **(Illustration 12)**. Torque the 12mm bolts and nuts to 75 ft. lbs. and the 1/2" bolts and nuts to 65 ft. lbs.

Illustration 12

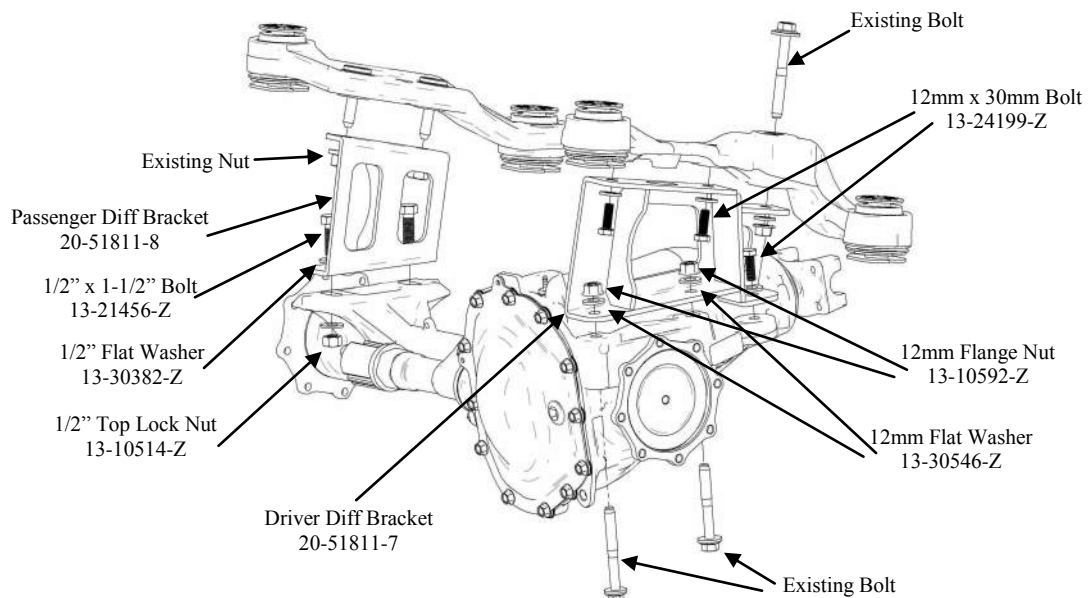

25. Re-attach vent hose and electrical wiring to front differential. Reconnect front drive shaft to the differential. Torque bolts to 19 ft. lbs.

26. Install two of the bumpstops previously removed to RCD Rear Crossmember (20-51811-2) as shown. **(Illustration 13).**

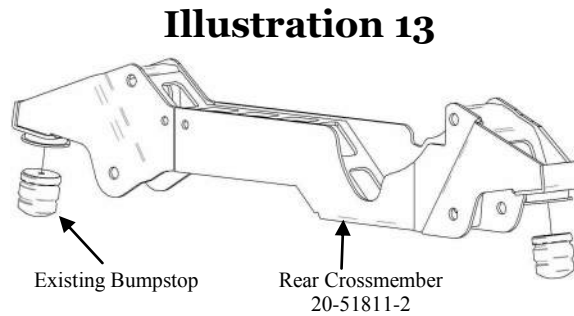

27. Install Rear Crossmember into original lower control arm pockets using existing hardware previously removed. **(Illustration 14).** Do Not Tighten.

28. Install Front Crossmember (20-51811-1) into original lower control arm pockets using existing hardware previously removed. **(Illustration 15).** Do Not Tighten.

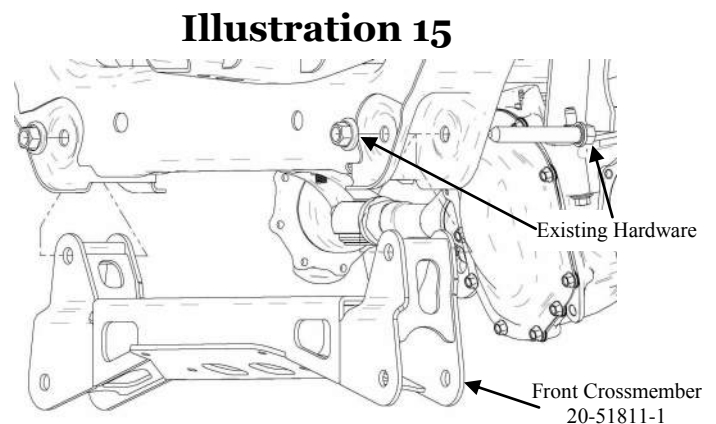
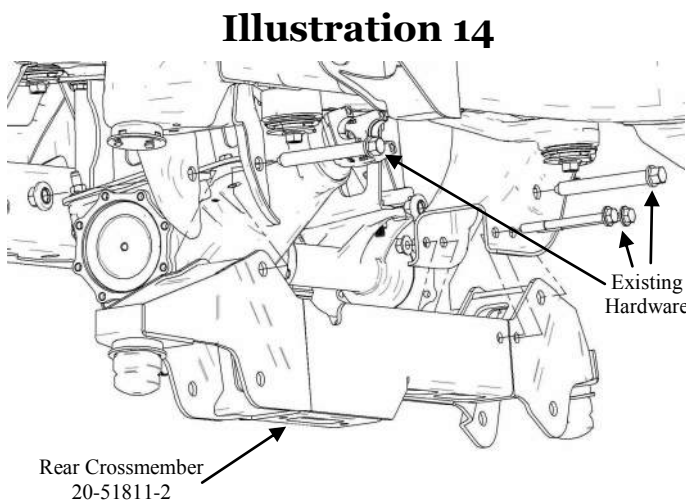

29. Install bumpstop previously removed into Bumpstop Bracket (20-51811-3) and attach to vehicle using 1/4" self drilling screws provided. **(Illustration 16).** Repeat process on opposite side.

Note: Bumpstop will offset to the front of vehicle slightly.

Illustration 16

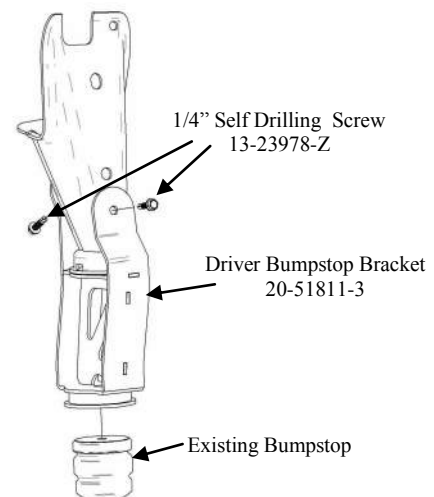

30. Install lower control arms using 18mm x 120mm bolts at front and 18mm x 140mm bolts with Compression Strut Brackets (20-51811-18) at rear. **(Illustration 17)**. Do Not Tighten.

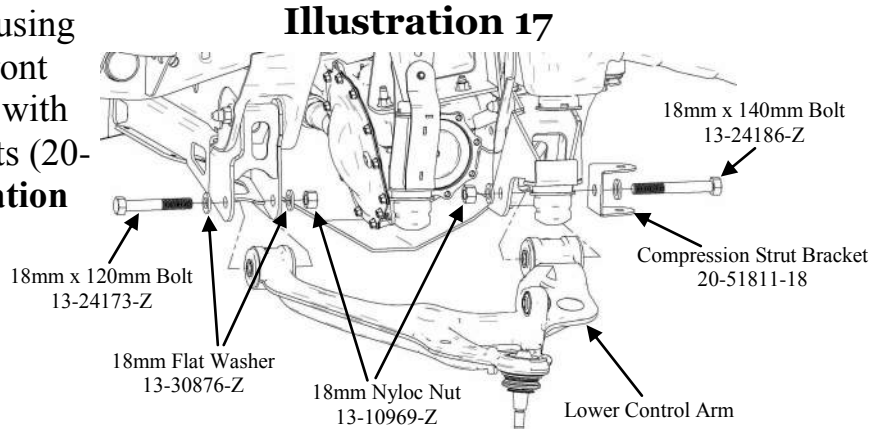

31. Attach Skid Plate (20-51811-9) to crossmembers using 3/8" hardware provided. **(Illustration 18)**. Torque 3/8" bolts to 30 ft. lbs.

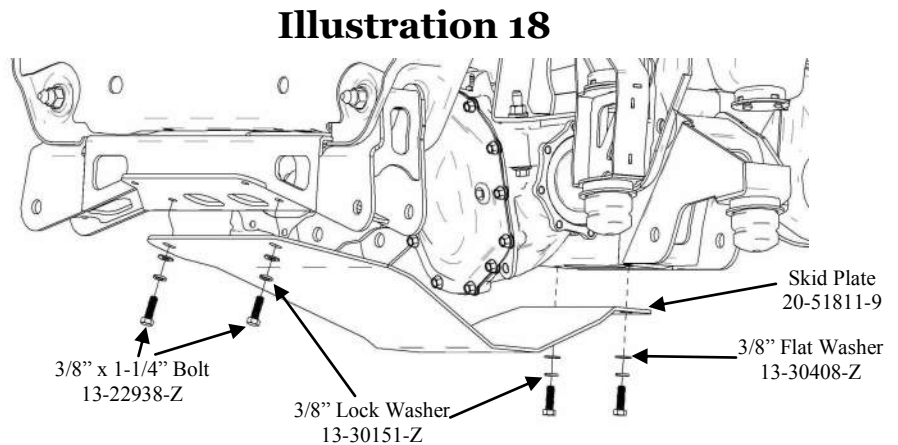

32. Remove the hub and bearing assembly from front spindle. Remove existing O-ring and splash shield. Install the O-ring, splash shield and hub & bearing assembly to new Front Spindle (20-51811-5D) and (20-51811-6P).
NOTE: Make sure hub and bearing assemblies are reinstalled on the same side they were removed from. Apply Loctite compound to existing hardware. Torque bolts to 130 ft. lbs.
33. Connect driver side front spindle assembly to the upper and lower control arm ball joints. Torque upper ball joint nut to 37 ft. lbs. Torque lower ball joint nut to 74 ft. lbs.
34. Rotate tie rod end 180 degrees and attach to spindle using nut previously removed. Torque nut to 37 ft. lbs.
35. Reinstall drive axle into front spindle using nut and washer previously removed. Torque nut to 150 ft. lbs.

Illustration 19

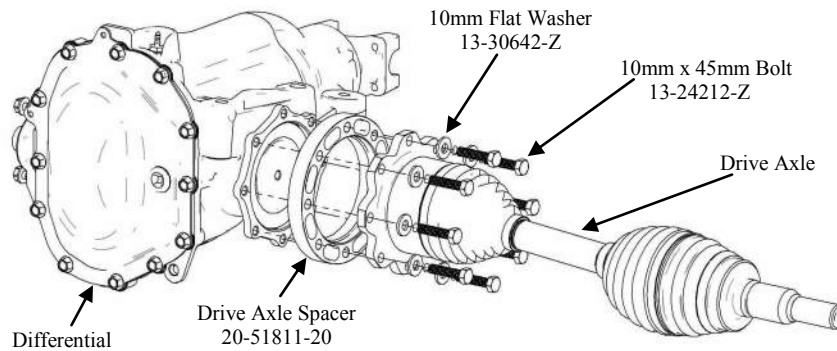

36. Place Drive Axle Spacer (20-51811-20) against differential flange (**Illustration 19**). Align reference marks on the axle flange and differential flange. Make sure all mounting holes are aligned with each other. Attach using Loctite compound and 10mm hardware provided, torque bolts to 58 ft. lbs.

37. Install wheel speed sensor in wheel hub using bolt previously removed.

38. Install brake rotor and attach using Torx bolt previously removed. Attach caliper assembly to steering knuckle using hardware previously removed. Torque caliper-to-knuckle mounting bolts to 220 ft. lbs.

39. Remove bolt attaching brake line to frame and insert Brake Line Bracket (20-51811-10) between brake line and frame. Attach bracket to frame with bolt previously removed and to brake line with 5/16" hardware provided.

Illustration 20

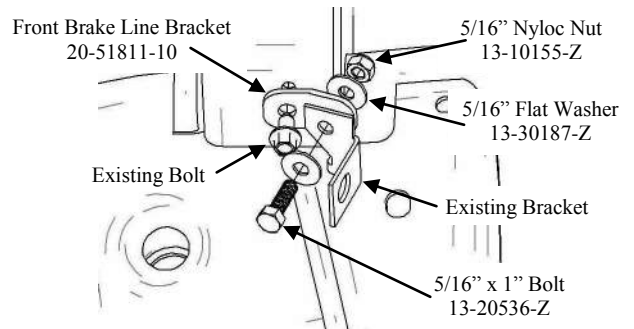

40. Attach brake line to steering knuckle using hardware previously removed. Tie speed sensor wire to brake line.

41. Install new longer front Shock Absorbers (59-71811-1).

42. Re-install front skid plate using existing hardware previously removed and 5/16" hardware provided. (**Illustration 21**).

Illustration 21

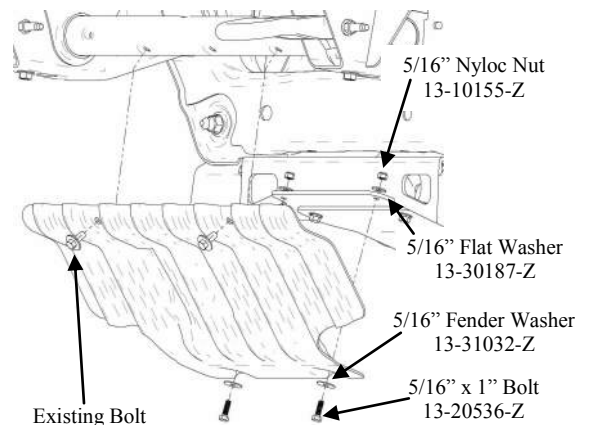

43. Install extended Sway Bar Links (20-835605). (**Illustration 22**).

44. Install Bushings (15-11148) and Sleeves (20-830918) into both ends of Lateral Compression Struts (20-51811-17). Attach Lateral Compression Strut to the strut mount bracket located on Rear Crossmember using hardware provided (**Illustration 23**). Do not tighten at this time.

45. Attach Strut Mount Bracket (20-51099-22) to opposite end of Compression Strut. Using the bracket as a guide, mark and center punch the mounting hole locations. Drill 11/32" diameter hole at each of the marked locations. Install using the 3/8" self-tapping hardware provided. (**Illustration 23**). Torque 3/8" bolts to 30 ft. lbs. and 1/2" bolts to 65 ft. lbs.

Illustration 22

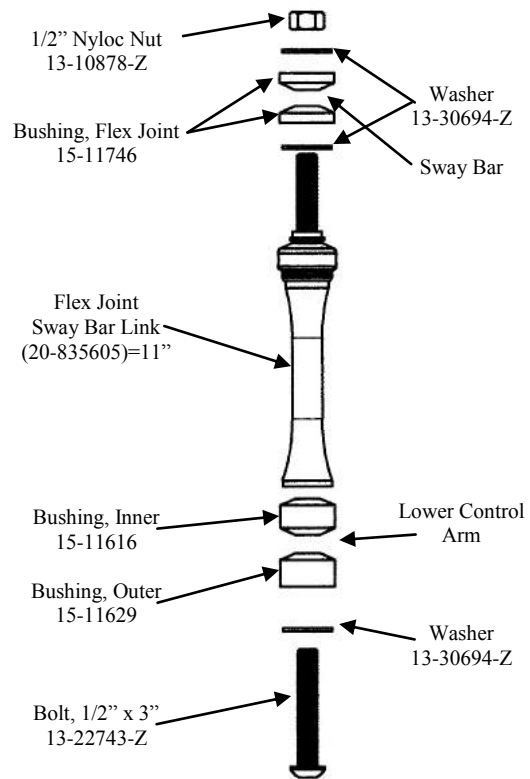

Illustration 23

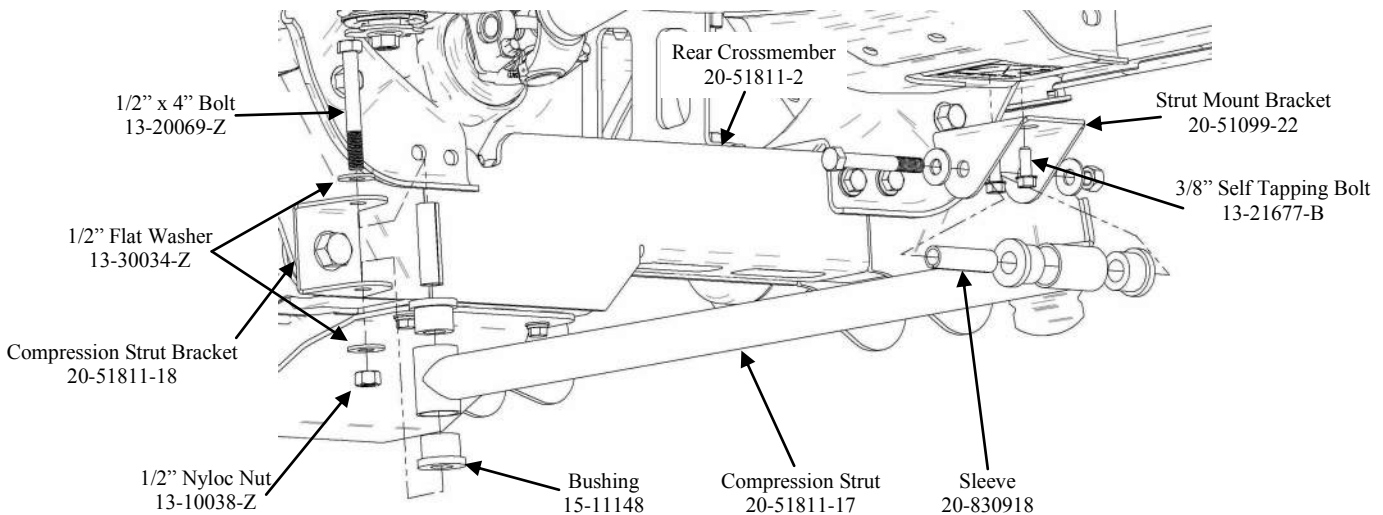
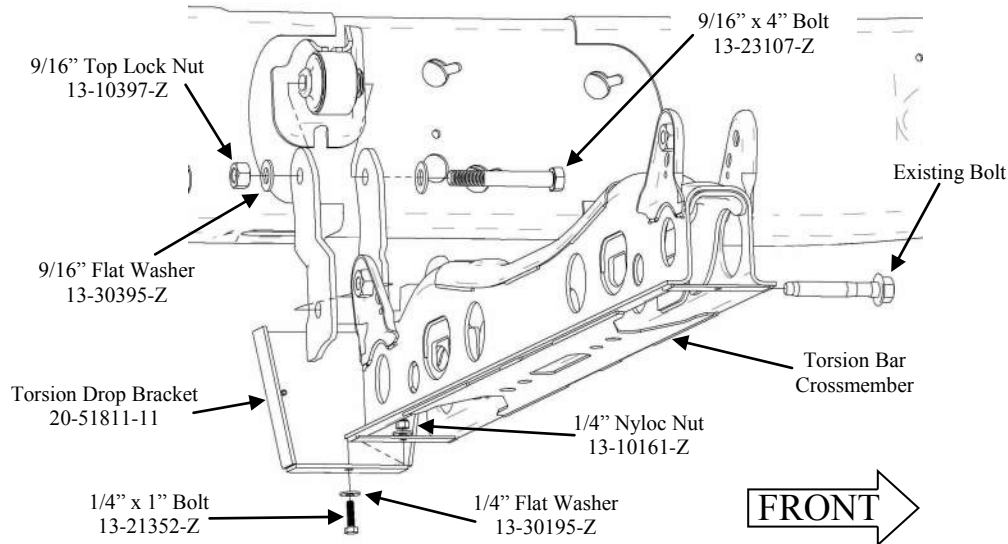

Illustration 24



46. Locate torsion bar crossmember previously removed. Drill two small holes in bottom of crossmember out to 1/4". Attach Torsion Drop Brackets (20-51811-11 and 20-51811-12) to crossmember, using existing bolts previously removed and 1/4" hardware provided. **(Illustration 24)**. Do Not Tighten.
47. Insert torsion bars into their respective lower control arms. Slide torsion bars forward.
48. Install torsion bar crossmember assembly using 9/16" hardware provided. **(Illustration 24)**. Torque the 9/16" bolts and existing bolts to 95 ft. lbs.
49. Slide torsion bars rearward through the torsion bar crossmember while holding adjustment arm in the proper position. Verify that reference marks on adjustment arm and torsion bar match.
50. Install the Torsion Bar Unloading Tool (J 36202). Be very careful while increasing tension on the torsion bar.
51. Reinstall retainer plate and adjusting bolt. Thread adjusting bolt until exposed length matches the measured length before removal. This way, they can be installed in the stock position.
52. Install front wheels and lower vehicle to the ground. Torque lug nuts to 140 ft. lbs.
53. When vehicle is at ride height, torque lower control arm to front and rear crossmember pivot bolts and existing crossmember bolts to 250 ft. lbs.

Rear Installation Instructions

1. Raise the vehicle. If working without a shop hoist, support vehicle with suitable safety stands. To do this, put vehicle in gear, block front wheels, both in front and behind tires, then disengage emergency brake. Place floor jack underneath rear axle and raise vehicle. Place suitable safety stands under frame to support vehicle and lower vehicle onto safety stands. Remove rear tire/wheel assemblies.
2. Locate the Parking Brake Cable on the driver side of vehicle where it attaches to Rear Spring Hanger. Remove bracket attaching cables to spring hanger.
3. Locate place where Rear Brake Hoses attach to frame. Disconnect this bracket from frame.
4. Install RCD Brake Line Bracket (20-51811-15) to frame using existing hardware. Attach Brake Line to new Bracket with 5/16" hardware provided. (**Illustration 25**).

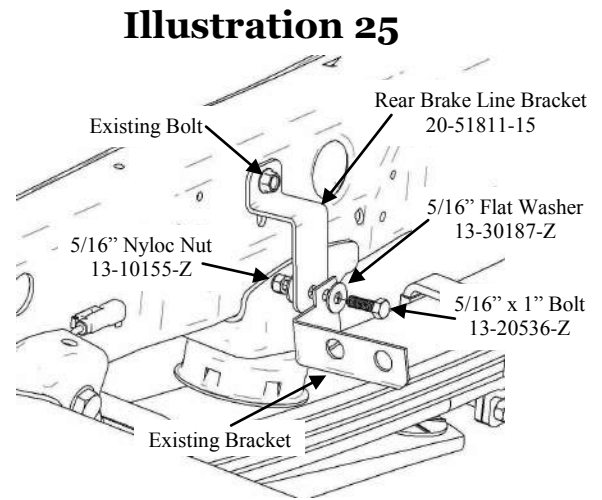

5. Disconnect speed sensor wire from brake line bracket on each side of rear axle.
6. Remove bolt attaching park brake cable to rear axle at center.
7. With the floor jack, raise the rear axle enough to relieve tension on the shock absorbers and remove shocks.
8. Remove the rear U-bolts attaching rear axle to driver side leaf spring. Carefully lower rear axle.
WARNING: Do not allow axle to hang by any hoses or cables.
9. Insert new Lift Block (20-833349-1D) on axle pad. Make sure the Block's pin indexes into the hole in the axle housing spring pad (**Illustration 26**). The wing on the Block faces the inside of the vehicle. Carefully raise rear axle until Block makes contact with leaf spring. Make sure the pin is aligned with the hole in Block.

10. Re-mount axle to spring using new U-bolts (13-91556), 3/4" Washers, 3/4" High Nuts and existing spring plates. Torque U-bolt nuts to 130 ft. lbs. (**Illustration 26**).

11. Repeat steps 8-10 on Passenger side of vehicle.

12. Install Park Brake Cable Bracket (20-51811-14) between axle and cable using existing bolt and 5/16" hardware provided. (**Illustration 27**).

13. Install Speed Sensor Brackets (20-51811-13) on each side of axle using 5/16" hardware provided. Clip speed sensor wire into bracket. (**Illustration 28**).

14. Install new Rear Shock Absorbers (50-BE5-6134-T5). Using existing hardware, attach shocks to lower axle mounts. Attach shocks to upper frame mounts and torque upper and lower nuts to 66 ft. lbs.

15. Install rear tire/wheel assemblies and lower vehicle. Torque lug nuts to 140 ft-lbs.

Illustration 26

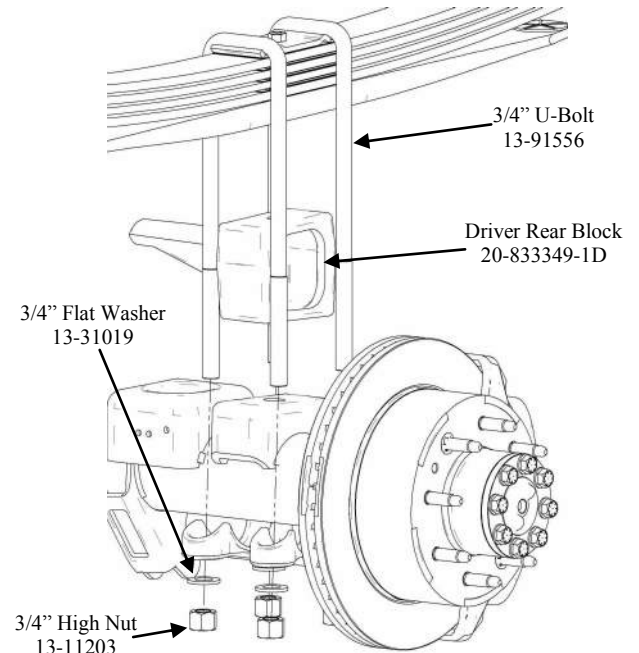

Illustration 27

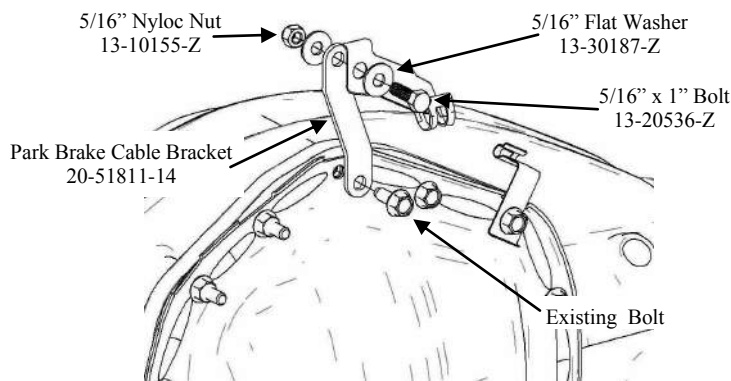
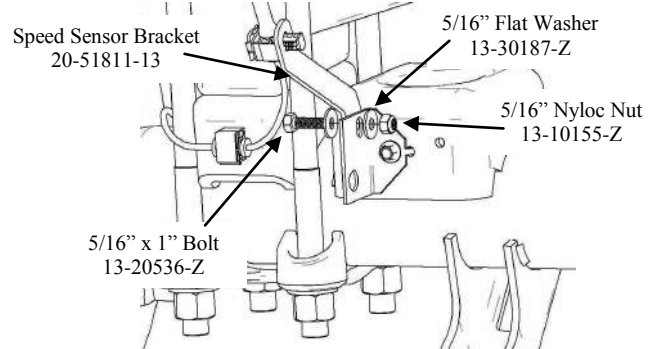

Illustration 28



SOME FINAL NOTES

- After installation is complete, double check that all nuts and bolts are tight. Refer to the torque specifications chart on last page.
- If new tires are installed that are more than 10% taller than original tires, the speedometer must be recalibrated for the Rear Wheel Anti-Lock Brake System to function properly. Contact an Authorized GM dealer for details on recalibration.
- With vehicle on the floor, cycle steering lock to lock and inspect steering, suspension and driveline systems for proper operation, tightness and adequate clearance. Recheck brake/hose fitting for leaks. Be sure all hoses are long enough.
- Have headlights readjusted to proper setting.
- Realign front end to factory specifications. Be sure vehicle is at desired ride height prior to realignment.

Torque Specifications

General Torque Specifications:

5/16"	20 ft. lbs.	M6	9 ft. lbs.
3/8"	35 ft. lbs.	M8	23 ft. lbs.
7/16"	60 ft. lbs.	M10	45 ft. lbs.
1/2"	90 ft. lbs.	M12	75 ft. lbs.
9/16"	160 ft. lbs.	M14	120 ft. lbs.
5/8"	175 ft. lbs.	M16	165 ft. lbs.
3/4"	250 ft. lbs.	M18	220 ft. lbs.

Existing Hardware Torque Specifications:

Wheel Hub-to-Wheel Knuckle Bolts	130 ft. lbs.
Front Differential Mounting Nuts, Pass. Side	75 ft. lbs.
Front Differential Mounting Bolts 12mm	87 ft. lbs.
Front Driveshaft/Front Differential Pinion Flange Bolts	19 ft. lbs.
Lower Control Arm Mounting Bolts	250 ft. lbs.
Lower Ball Joint Nut	74 ft. lbs.
Axle Nut	148 ft. lbs.
Upper Ball Joint Nut	37 ft. lbs.
Tie Rod Nut	37 ft. lbs.
Caliper Mount to Steering Knuckle Bolts	220 ft. lbs.
Front Shock, Upper Mount Nuts	37 ft. lbs.
Front Shock, Lower Mount Bolts	37 ft. lbs.
Wheel Lug Nuts	140 ft. lbs.
Front Halfshaft to Differential Bolts	58 ft. lbs.
U-Bolt Nuts	130 ft. lbs.
Rear Shock, Upper and Lower Mount Nuts	52 ft. lbs.