



4/4/13

**'88-'98 CHEVROLET/GMC  
IFS 4WD(6LUG)  
6" SUSPENSION SYSTEM**

**P/N. 10-41089**

**INSTALLATION INSTRUCTIONS**

**APPLICATION WARNING:** Applicable for hub mounted ABS sensor models only.  
Not for 1992-94 Suburban/Blazers with external spindle mounted ABS.

**NOTE:** Each Lift Kit, and options to Lift Kits, are packaged separately. Therefore installation procedures are covered in separate instructions. Familiarize yourself with each set of instructions before beginning.

## **PART LIST**

<b>ITEM</b>	<b>DESCRIPTION</b>	<b>QTY.</b>	<b>ILLUS.</b>
<b><u>Box 1 of 6</u></b>			
20-51089-1	Front Crossmember	1	11
20-51089-2	Rear Crossmember	1	11
<b><u>Box 2 of 6</u></b>			
20-51089-10P	Front Spindle (Pass.)	1	
20-51089-11D	Front Spindle (Drvr.)	1	
20-68708	Hardware Pack Containing: (Cotter Pin)		
13-90607	Cotter Pin, 1/8" x 1-1/2"	4	
<b><u>Box 3 of 6</u></b>			
20-51089-3	Lateral Compression Struts	2	14
20-51099-22	Bracket, Strut Mount	2	14
20-67889	Hardware Pack Containing: (Compression Strut)		
15-11148	Bushing, Red	8	14
20-830918	Sleeve, 3/4" x 2-3/4"	4	14
20-832738	Sleeve, 3/4" x 1.00"	2	14
20-67902	Hardware Pack Containing: (Compression Strut)		
13-20069-Z	Hex Bolt, 1/2"-13 x 4"	4	14
13-21014-Z	Hex Bolt, 1/2"-13 x 3"	2	14
13-30034-Z	Flat Washer, 1/2"	12	14
13-10038-Z	Nyloc Nut, 1/2"-13	6	14
<b><u>Box 4 of 6</u></b>			
20-51089-5	Bracket, Torsion Bar Drop	2	15
20-51089-7	Bracket, Differential Support	1	9
20-51089-8	Bracket, Differential Drop	1	10
20-830554	Cap, Frame	1	7
20-830671	Block, Tapered Rear- 3"	2	18
13-90646	U-Bolt, 9/16"-18 x 12-1/2"	4	18
20-68188	Hardware Pack Containing: (U-Bolt Hardware)		
13-30330	Flat Washer, 9/16" Hrdn. Plain	8	18

13-10423	High Nut, 9/16"-18 Fine	8	18
20-68305	Hardware Pack Containing: (RCD Universal)		
13-20447-Z	Unslot Hex, #10 x 1/2"	4	
15-10966	Clamp, 3/8" x 3/8" x .203	4	
15-11395	Wire Tie, 6"	4	
15-11447	Wire Tie, 8"	2	
15-11460	Wire Tie, 11"	2	
20-68734	Hardware Pack Containing: (Brake Lines)		
50-5189-1	Brake Line Kit, Chevy IFS	2	
50-5189-2	Brake Line Crush Washer	4	
20-65354	Hardware Pack Containing: (Cambolt Kit)		
20-51088-10	Cam-Bolt, Rear Crossmember	2	
20-51088-15	Cam-Bolt, Front Crossmember	2	
20-831867	Washer, Cam 2" OD	4	
13-10345-Z	Top Lock Nut, 5/8"-11	4	
13-90490	Loctite Compound	1	
20-69917	Hardware Pack Containing: (Sway-Bar Extension)		
20-833739	Sway-Bar Extension, 9-1/2"	2	16
13-22743-Z	Bolt, 1/2"-13 x 3" Button Head	2	16
13-30694-Z	Washer, Bushing Retainer 1-1/4"	6	16
13-10878-Z	Nyloc Nut, 1/2"-20	2	16
15-11616	Bushing, Sway-Bar Link Inner	2	16
15-11629	Bushing, Sway-Bar Link Outer	2	16
15-11746	Bushing, Sway-Bar Flex Joint	4	16
20-67863	Hardware Pack Containing: (Differential Bracket)		
13-21144-Z	Hex Bolt, 9/16"-12 x 3-1/2" Gr. 8	1	
13-22665-Z	Hex Bolt, 9/16"-12 x 1-3/4" Gr. 8	2	10
13-22704-Z	Hex Bolt, 7/16"-14 x 3" Gr. 8	1	9
13-22639-Z	Hex Bolt, 10mm x 1.5 x 60mm Gr. 10.9	4	9
13-30395-Z	Flat Washer, 9/16" Hrdn.	6	10
13-30304-Z	Flat Washer, 7/16" Hrdn.	2	9
13-30642-Z	Flat Washer, 10mm Hrdn.	4	9
13-10397-Z	Top Lock Nut, 9/16"-12 Gr. C	3	10

13-10384-Z	Top Lock Nut, 7/16"-14 Gr. C	1	9
15-11148	Bushing, Red	2	9
20-832725	Sleeve, 3/4" x 2.25"	1	9
20-68669	Hardware Pack Containing: (Torsion Bar Drop)		
13-21378-Z	Hex Bolt, 1/2"-13 x 3-3/4"	4	15
13-21417-Z	Hex Bolt, 3/8"-16 x 5"	2	15
13-30034-Z	Flat Washer, 1/2"	8	15
13-30012-Z	Flat Washer, 3/8"	4	15
13-10038-Z	Nyloc Nut, 1/2"-13	4	15
13-10022-Z	Nuloc Nut, 3/8"-16	2	15
20-68643	Hardware Pack Containing: (Upper Control Arm Alignment Tabs)		
20-832933	Tab, Upper Control Arm Align	8	12
13-22223-Z	Bolt, 9/16"-12 x 3-3/4" Gr. 8	4	
13-30395-Z	Flat Washer, 9/16" Hrdn.	8	
13-10397-Z	Top Lock Nut, 9/16"-12 Gr. C	4	
20-68500	Hardware Pack Containing: (Drive Axle Spacer)		
13-22886-Z	Hex Bolt, 10mm-1.5 x 70mm Gr. 10.9	12	13
13-30642-Z	Flat Washer, 10mm Hrdn.	12	13
13-90490	Loctite, Compound	1	
20-51089-20	Spacer, Drive Axle	2	13
20-68513	Hardware Pack Containing: (Rear Bumpstop)		
20-51089-12	Rear Bumpstop Ext. Chevy 88-98	2	
15-11031	Bumpstop, Medium Progressive	2	
13-20142-Z	Hex Bolt, 7/16"-14 x 1-1/4"	2	
13-30117-Z	Flat Washer, 7/16"	4	
13-30012-Z	Flat Washer, 3/8"	2	
13-10133-Z	Nyloc Nut, 7/16"-14	2	
13-10022-Z	Nyloc Nut, 3/8"-16	2	
20-68539	Hardware Pack Containing: (Existing Skid Plate Hardware)		
13-20081-Z	Hex Bolt, 3/8"-16 x 1-1/4"	4	
13-30012-Z	Flat Washer, 3/8"	8	
13-10022-Z	Nyloc Nut, 3/8"-16	4	
11-15144	Tube, 1" x .219 x .31	2	

20-68656	Hardware Pack Containing: (Rear Brake Line Extension)		
20-51089-13	Bracket, Rear Brake Line Extension	1	
13-20425-Z	Hex Bolt, 5/16-18 x 1-1/4"	1	
13-30187-Z	Flat Washer, 5/16"	2	
13-10155-Z	Nyloc Nut, 5/16"-18	1	
<b><u>Box 5 of 6</u></b>			
<b><u>Box 6 of 6</u></b>			
13-70039-1	Rear, Add-A-Leaf	2	17
20-68240	Hardware Pack Containing: (Spring Pins)		
13-90750	Pin, Center 3/8"-24 x 6" w/Nut	2	
20-68344	Hardware Pack Containing: (Add-A-Leaf)		
13-90737-1	Clamp, 2-1/2"	4	17
13-90737-2	Cap, 2-1/2"	4	

## **INTRODUCTION**

- 24-067379 Shock Absorber (Front) 2
  - 33-061399 Shock Absorber (Rear) 2
- Installation by a professional mechanic is recommended. Use of the appropriate power tools, a Chevrolet/GMC service manual and a shop hoist can greatly reduce installation time.
- Prior to installation, carefully inspect the vehicle's steering and drive train systems, paying close attention to the tie rod ends. Pitman and Idler Arms, Ball Joints and wheel bearing preload. Also check steering-to-frame and suspension-to-frame attaching points for stress cracks. The overall vehicle must be in excellent working condition; repair or replace worn parts.
- Read instructions carefully and study the illustrations before attempting
- Read installation. Race Car Dynamics is not responsible for damage, failure or injury resulting from improper installation or parts substitution of this kit.
- Check the parts and hardware against the parts list to assure that your kit is complete. Report any shortages to *RCD Suspension* at (1-619-588-4723). The parts and hardware supplied are of high-grade material and must not be replaced by inferior parts or failure may result.

- ❑ Separate parts according to the areas they will be used. Placing the hardware with brackets before you begin will save installation time.
- ❑ All components in this kit come with a protective coating. Do not plate (i.e. chrome, cadmium, zinc etc.) or otherwise alter the finish in any way. This could weaken the structural strength of the components.
- ❑ Secure and properly block vehicle prior to beginning installation.
- ❑ Always wear safety glasses when using power tools.
- ❑ Foot-pound torque readings are listed on the Torque Specifications chart at the end of the instructions unless specifically stated in an instruction. **DO NOT USE AN IMPACT WRENCH TO TIGHTEN ANY OF THE BOLTS.**

### **PLEASE NOTE**

- **WARNING:** DO NOT USE WHEEL SPACERS.
- Crossover exhaust pipe may need to be modified to clear front drive shaft.
- No special drive shaft is required. Stock drive shafts are retained.
- Clears 33" x 12.50" tires on 16 x 8" wheels, 35" x 12.50" with minor bumper trimming.
- Requires wheels with a maximum of 4.5" of back spacing on 16" wheels, 4.75 on 16.5" wheels. 8" wide wheels are highly recommended.
- Front system increases vehicle track width 2" for added stability.
- Due to inconsistent ride height from the factory some models may need an optional Add-a-leaf to level the vehicle (call for part number). System may require rear driveline modification if over 5" of rear lift is achieved with block and Add-a-leaf combination.
- Front end alignment is required.
- Vehicles equipped with a rear sway bar must order #20-68786 extended rear sway bar link kit.
- Special tools are required for safe removal and installation of the Ball Joints, Tie-Rods, and Torsion Bars. These tools can be purchased from your GM Dealer.

Torsion Bar Unloading Tool # J 36202  
Steering Linkage Puller J 24319-B  
Ball Joint Separator Tool # J 23742  
Knockout Removal Tool #38794

## **FRONT DISASSEMBLY**

1) GETTING STARTED: Measure ride height with vehicle supporting it's own weight. Ride height is the measured distance from center of spindle-to-top of the fender well (**Illustration 1**). Raise the vehicle. If working without a shop hoist support vehicle with suitable safety jack stands. Put vehicle in gear, set emergency brake and block rear wheels, in front and behind tires. Loosen front wheel lug nuts. Place floor jack under the lower control arm's front crossmember and raise vehicle. Place safety jack stands under frame rails, behind front wheel wells, and lower the frame onto the stands. Remove front wheels.

Ride Height Measurement

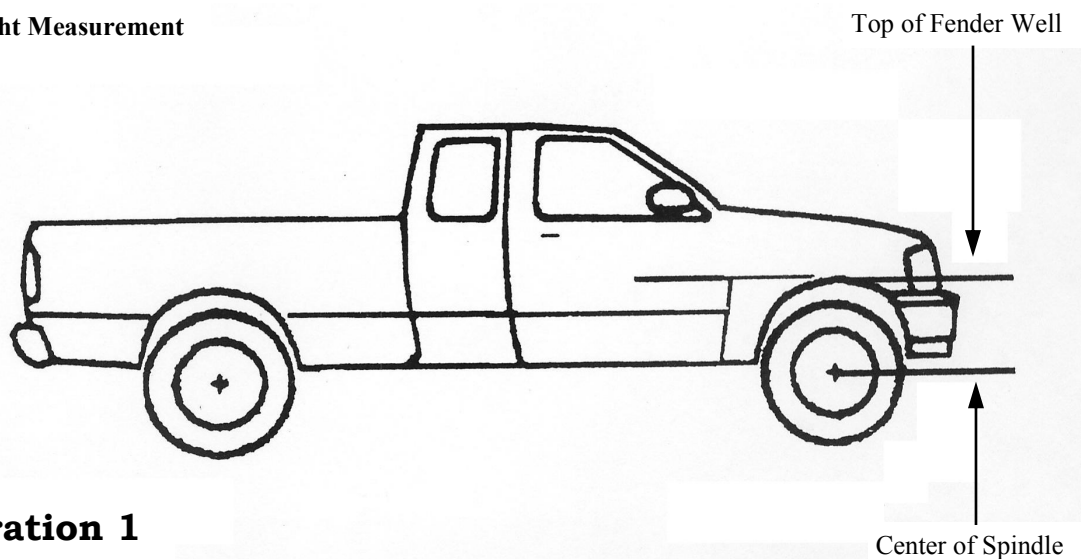

**Illustration 1**

**WARNING: Be extremely careful when loading or unloading the torsion bars. There is a tremendous amount of stored energy in the bars. Keep your hands and body clear of adjuster arm assembly and puller tool in case anything breaks.**

2) Measure Torsion Bar Adjusting Screw depth for replacement of Torsion Adjuster Arm later. Mark bars and arms as an assembly for installation later. Remove the torsion bar adjusting screw. Apply a small amount of lubricating grease to the Torsion Bar Unloading Tool (J 36202) threads and the tool shaft-to-adjuster arm contact point. Position the Unloading Tool and load adjuster arm until adjuster nut can be removed from the crossmember (**Illustration 2**). With the bar unloaded, slide it further forward into the lower control arm. If the bar seems lodged, use a hammer to punch through the hole in the back of crossmember. When bar shifts forward, the adjuster arm will fall.

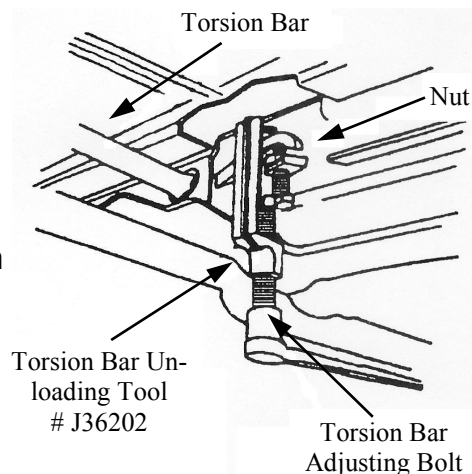

### Illustration 3

3) Remove torsion bar crossmember by removing bolts that connect crossmember to the frame. With crossmember out of the way, the torsion bars can be dislodged from lower control arms and removed. Mark or separate the bars, since each bar must be reinstalled on the same side that it was removed from.

4) Remove the front shock absorbers and detach existing front bumpstops from upper mounting cup.

5) Remove anti-sway bar drop links, which connect bar body to lower control arms (**Illustration 3**).

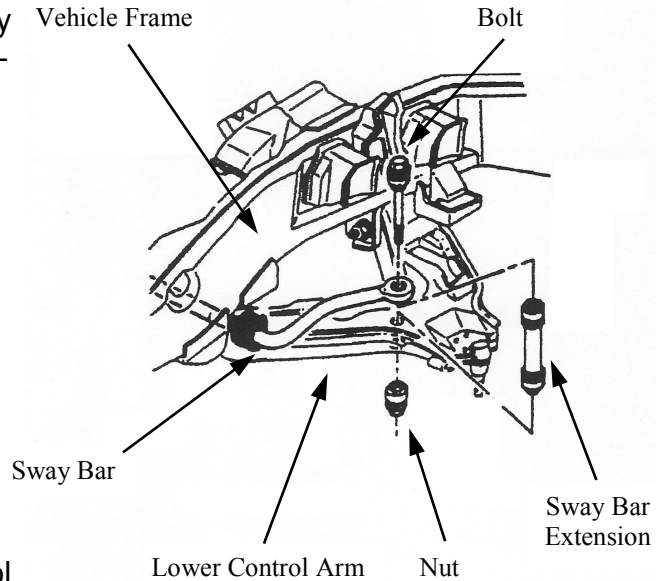

6) Locate and place an index mark, for installation reference, on both the differential flange and the drive axle flange.

7) Remove the nut and washer from the hub (**Illustration 4**). Remove the six existing bolts fastening drive axle to differential. Pull drive axle out of the hub through lower control arm.

**NOTE:** Be careful not to damage the drive axle boots.

8) Disconnect brake hose from caliper and plug end of hose to prevent fluid loss. Locate and remove the two Alien Head bolts attaching brake caliper mounting bracket to backside of front spindle. Remove the brake caliper assembly from brake rotor (**Illustration 4**).

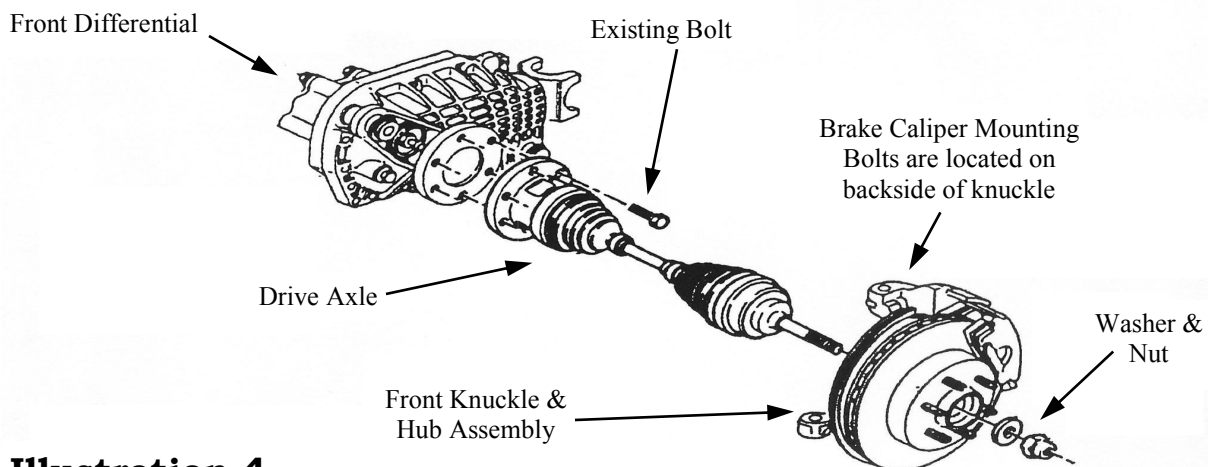

### Illustration 4



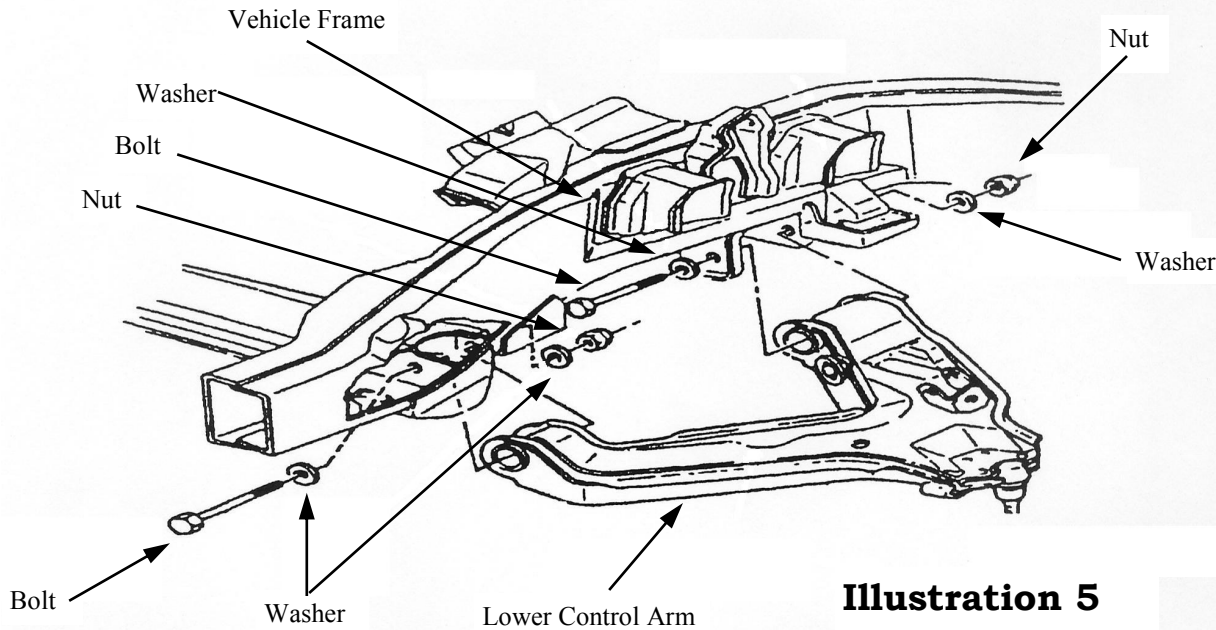

**Illustration 5**

**9)** Remove brake rotor. Locate tie rod end and remove the nut. Attach Universal Steering Link Puller (J 24319-B) and separate tie rod end from front spindle.

**10)** If applicable, separate the ABS sensor cable at the frame and upper control arm.

**11)** Locate front lower ball joint. Remove nut from ball joint. Using Ball Joint Separator Tool (J 23742) apply pressure on tool until ball joint breaks loose from lower part of the front spindle.

**12)** Locate front upper ball joint. Remove nut from ball joint. Using Ball Joint Separator Tool (J 23742) apply pressure on tool until ball joint breaks loose from upper part of the front spindle.

**13)** Remove front spindle with hub and bearing assembly attached, set aside. Remove the lower control arm pivot bolts and remove lower control arm (**Illustration 5**).

**Repeat steps 4 thru 13 on opposite side.**

**14)** Remove the differential skid plate, if vehicle is so equipped.

**15)** Locate front drive shaft U-joint to differential yoke. Place an index mark for installation reference on both the drive shaft U-joint and differential yoke. Remove hardware from the yoke and slide the shaft rearward to disengage. Tape bearing cap assemblies and secure shaft out of the way.

**16)** Disconnect the electrical connector and vent hose from differential assembly.

**17)** Support front differential assembly with a floor jack. Remove upper mounting hardware and passenger side axle hardware (**Illustration 6**). Slowly remove the differential assembly from vehicle, and lower it to the floor.

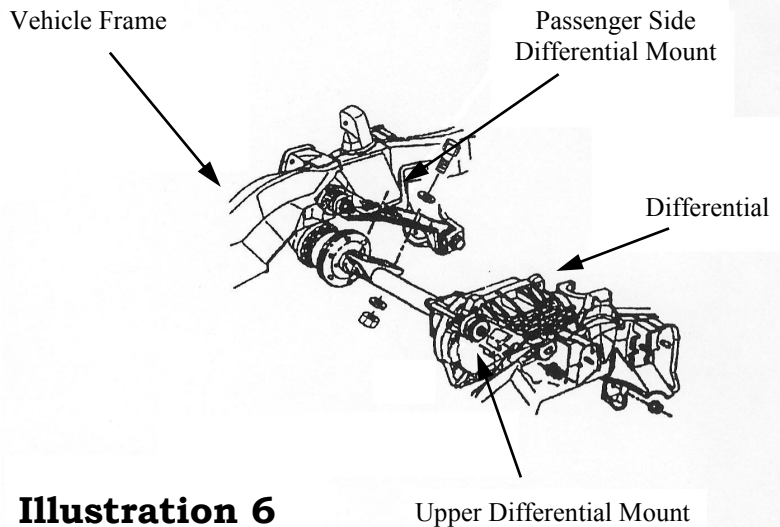

**Illustration 6**

**18)** Using a suitable cutting tool, cut off the rear lower differential mount bracket (driver's side), plus an additional one-inch of the frame supporting the bracket. (**Illustration 7**). Weld in the provided Frame Cap (20-830554). File all sharp edges and paint exposed metal.

Rear Lower Differential Mount (Drvr Side).

**NOTE:** Use suitable cutting tool & cut off as shown. Do not use cutting torch

Weld Cap in place, 20-830554

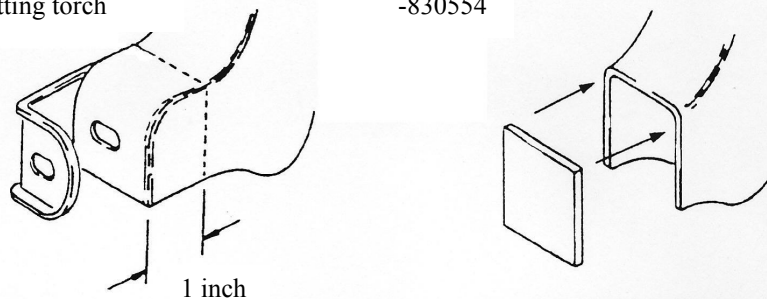

**Illustration 7**

**19)** Locate the upper mount on front differential housing. Cut off upper mount flush to main case (**Illustration 8**). If the driver side lower differential mount bracket was properly modified grinding to clearance the case will not be necessary. If necessary, remove material from the left side of the differential to provide clearance for the lower control arm frame mount.

**Illustration 8**

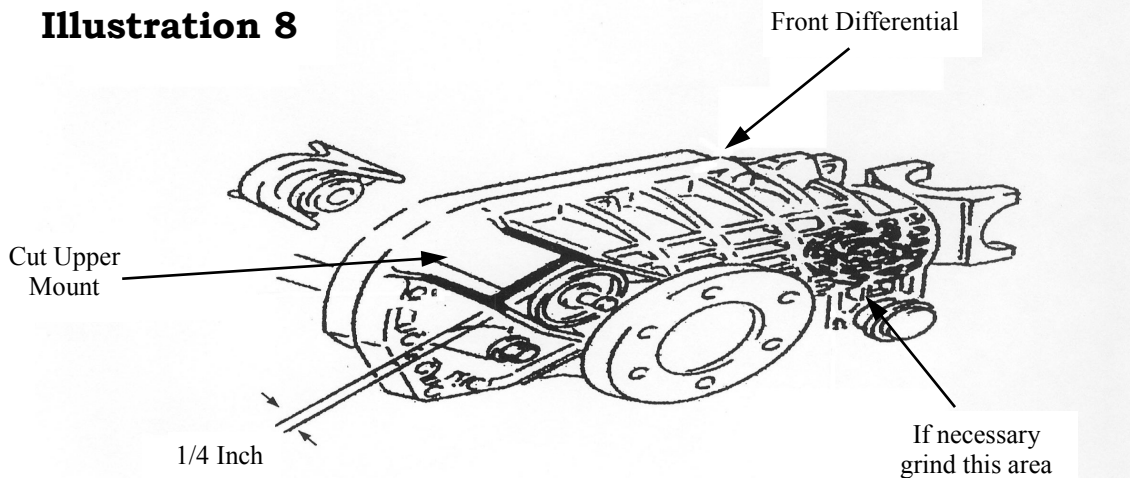

## **FRONT INSTALLATION**

1) Install Bushings (15-11148) and Sleeve (20-832725), into Differential Support Bracket (20-51089-7). Attach differential support bracket assembly to front differential (**Illustration 9**). Use Loctite compound and hardware provided. Torque to specification chart on last page of instructions.

**NOTE:** When attaching differential support bracket, gear oil may leak from case. Place this assembly in a large oil pan before removing hardware to catch spilled oil. While on the bench add one pint of GM's recommended differential fluid before installing differential.

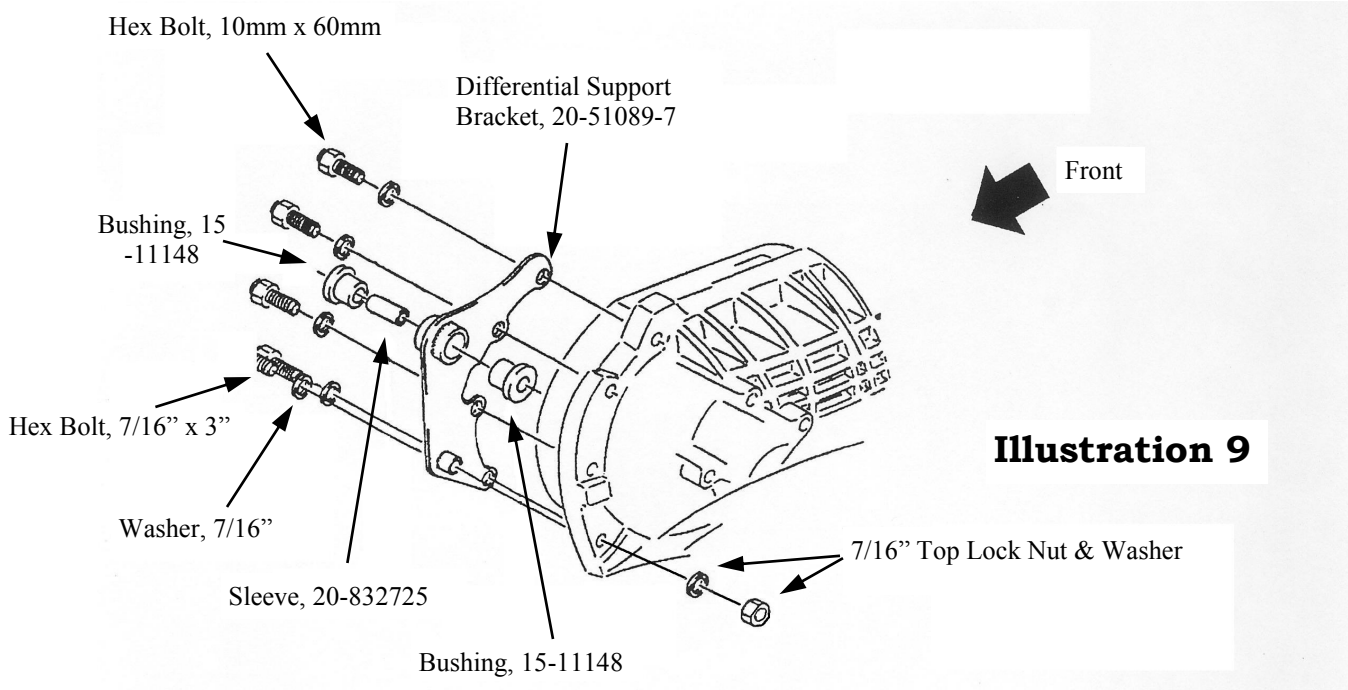

2) Loosely attach the passenger side Differential Drop Bracket (20-51089-8), to differential axle with hole in bracket facing front of vehicle. Use hardware provided (**Illustration 10**).

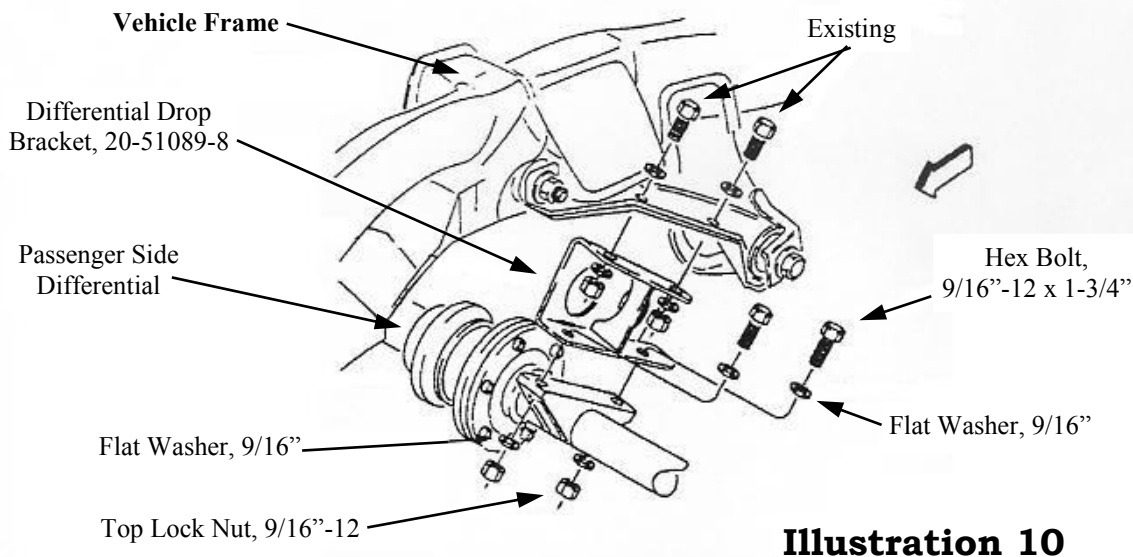

**Illustration 10**

3) Install Rear Crossmember (20-51089-2) into existing rear lower control arm mounting pockets (**Illustration 11**). Use existing hardware previously removed with bolt heads facing front of vehicle. Do not fasten at this time.

4) Support front differential assembly with a floor jack. Slowly raise differential into position and check for fit and clearance. If necessary, grind differential housing for clearance.

**NOTE:** Install existing hardware with bolt heads facing front of vehicle

**Illustration 11**

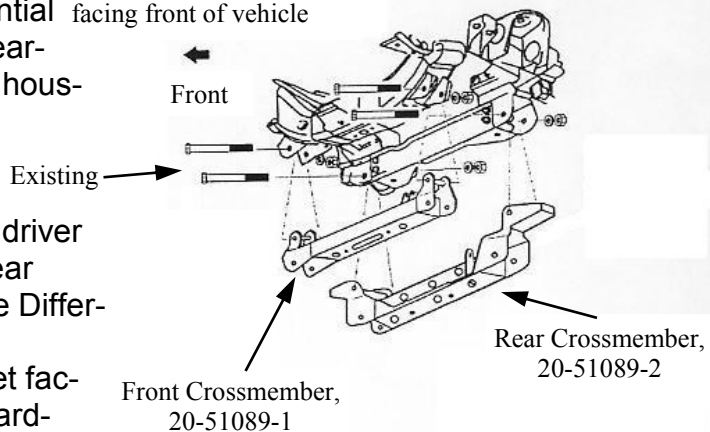

5) Install front differential (use hardware previously removed). The rear driver side differential mount attaches to rear crossmember. Install passenger side Differential Drop Bracket to frame (with hole in bracket facing front of vehicle). Do not fasten hardware at this time.

6) Install Front Crossmember (20-51089-1) into existing front lower control arm mounting pockets using existing hardware previously removed. Make sure bolt heads face front of vehicle. Place front differential support bracket between tabs provided on front crossmember. Do not tighten at this time.

7) Check that differential is mounted square in frame. Take Left-to-Right as well as Front-to-Back measurements and adjust fit. Tighten differential hardware at this time.

**NOTE:** If differential contacts crossmember, grind crossmember for clearance.

8) Install lower control arms into front and rear crossmembers using 5/8" Cam Bolt (20-51088-10 Rear), (20-51088-15 Front) hardware provided.

**NOTE:** Front crossmember cam bolt heads face forward and rear crossmember cam bolt heads face to the rear of vehicle. Do not tighten hardware at this time. To adjust lower cam bolts, adjust fixed cam side and tighten non-fixed cam nut.

9) Locate upper control arm frame mounting bracket(s) on the frame. Use Tool #J 38794 to remove frame bracket knockouts. Be careful not to distort frame bracket when removing knockout. Before working with tool apply extreme pressure lubricant to threads of T-bolt on tool- Insert bolt through knockout hole in bracket and install the tool bridge onto T-bolt. The bridge should span the knockout without interference. The forward bracket requires bridge to be installed between legs of bracket for proper access.

**NOTE:** Do not apply more than 75 ft. lbs. torque to prevent damage to tool and/or bracket. If torque limit is met and knockout does not break free use an appropriate size die grinder to remove knockout.

10) Install Upper Control Arm Alignment Tab (20-832933) against upper control arm frame mounting bracket with bolt-hole in tab towards frame (**Illustration 12**) using 9/16" bolts provided. Torque bolts to 121 ft. lbs.

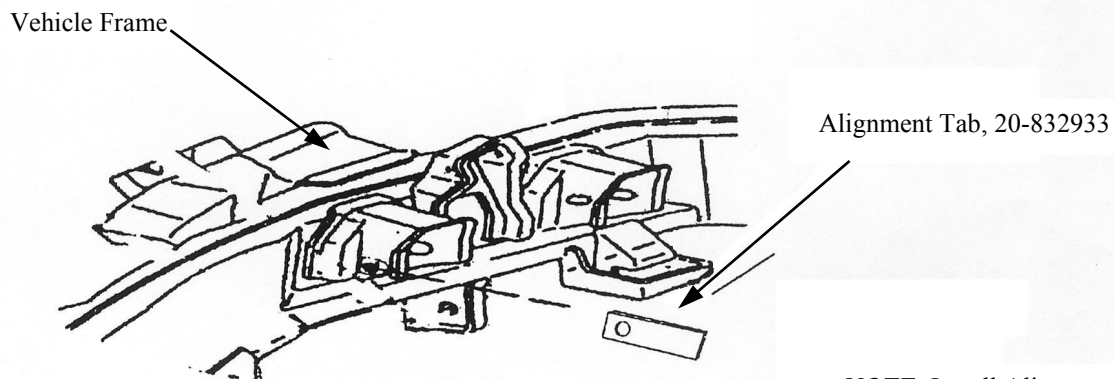

**NOTE:** Install Alignment Tab with bolt hole towards frame.

**Illustration 12**

**NOTE:** Alignment Tab (20-832933) fixes the upper control arms. Alignment will now be made with the lower control arms.

11) Reconnect differential vent hose and electrical connector.

12) Install front drive shaft, making sure alignment marks made during disassembly are matched.

**NOTE:** The exhaust crossover pipe may need to be modified to clear front drive shaft.

13) Remove hub and bearing assembly (also splash shield if applicable) from existing front spindles and install to new Front Spindles (20-51089-11D Drvr.) and (20-51089-10P Pass.)

**NOTE:** Make sure hub and bearing assemblies are installed on the same side they were removed from. Apply thread locking compound to existing hardware. Torque bolts to 133 ft. lbs.

14) Connect driver side front spindle assembly to upper and lower arm ball joints. Torque upper ball nut to 74 ft. lbs. Torque lower ball joint nut to 94 ft. lbs. Install new cotter pins.

15) Reinstall the drive axle into front spindle and attach with hardware previously removed.

**NOTE:** Do not lubricate the drive axle splines and front spindle with grease.

16) To install drive axle spacer, apply thread locking compound to hardware provided. Place Drive Axle Spacer (20-51089-20) against differential flange (**Illustration 13**). Align reference marks on drive axle to those on differential flange. With mounting holes aligned attach assembly and torque bolts to 58 ft. lbs.

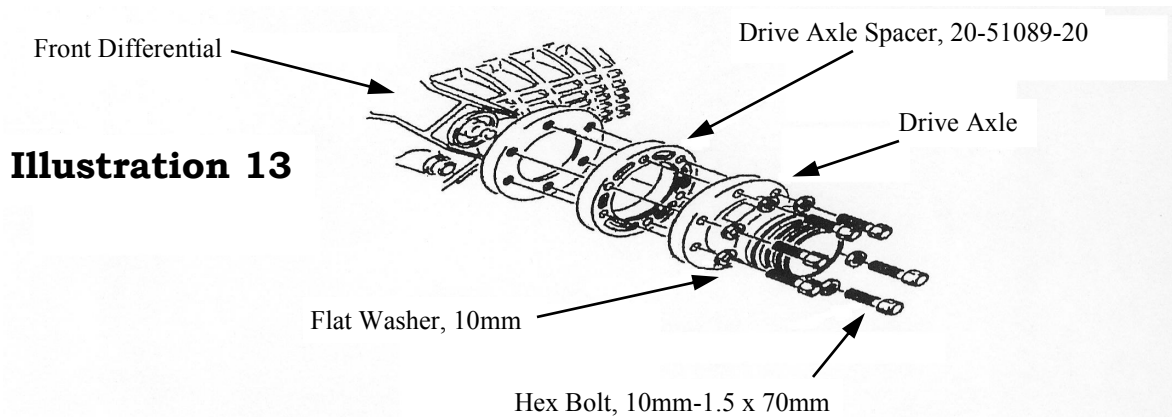

17) Install brake rotor, caliper assembly and new longer Brake Line (50-5189-1) with Crush Washer (50-5189-2). Route Brake Line through upper control arm and attach to spindle with tie wrap. Use existing hardware to attach caliper mounting bracket to spindle. Torque caliper Alien Head bolts to 38 ft. lbs.

18) Torque axle hub nut to 165 ft. lbs.

19) Install front bumpstops.

20) Install new longer front Shock Absorbers (BE5-6139-H5).

21) Cycle front suspension through full travel cycle and check for adequate clearance between shocks and brake line hoses.

**Repeat steps 14 thru 21 on opposite side.**

22) Tighten all fasteners to specifications. Refer to Torque Specifications on last page if torque value was not called out in preceding steps.

23) Install Bushings (15-11148) and Sleeves (20-830918) into both ends of Lateral Compression Struts (20-51089-3). Attach Lateral Compression Strut-to-strut mount bracket located on the rear crossmember using hardware provided (**Illustration 14**). Do not tighten assembly at this time.

24) Attach Strut Mount Bracket (20-51099-22) to opposite end of the compression strut (**Illustration 14**). Compression struts attach to trans crossmember existing holes after the bottom existing hole is drilled out to 1" inch. Insert Sleeve (20-832738) into drilled hole.

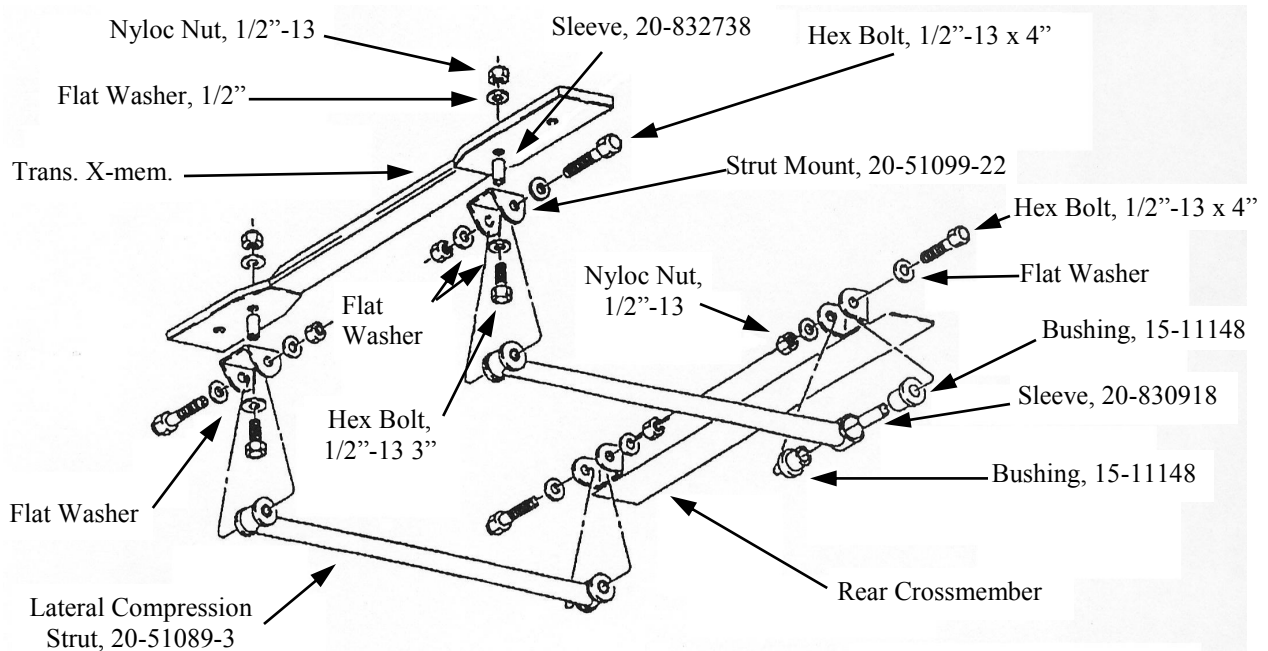

**Illustration 14**

**NOTE:** The Sleeve fits inside crossmember, preventing the frame from crushing when bolts are torqued. Use 1/2" hardware provided and torque nuts to 65 ft. lbs.

**25)** Insert torsion bars into the lower control arms. The bar's rear facing ends are now hanging. This step is a two-man operation. Balance the crossmember with a suitable floor jack and raise it to mate with the hanging bar ends. Now locate the adjuster arms inside the crossmember and onto the bar ends.

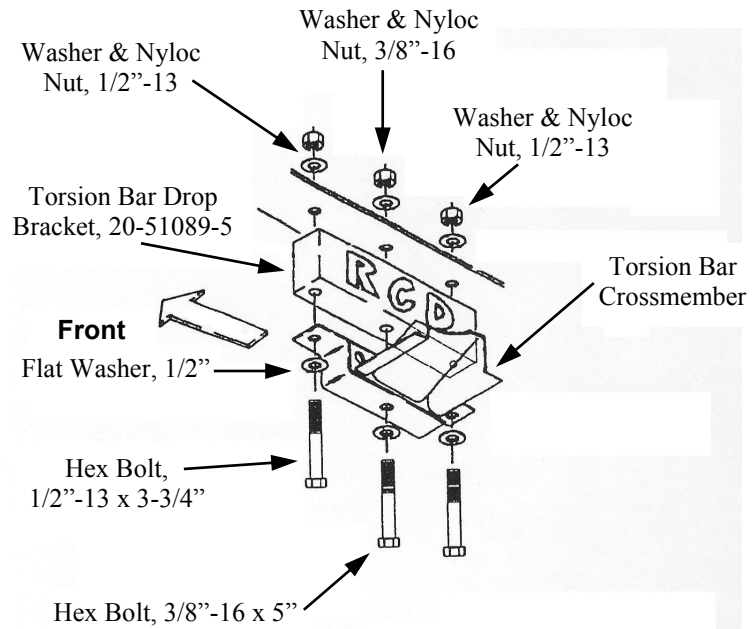

**Illustration 15**

**26)** Remove the endcaps of the torsion bar crossmember which contain the rubber bushings. Flip the endcaps upside down, and re-install the torsion bar crossmember with the new Torsion Bar Drop Brackets (20-51089-5) on the bottom of the frame rail as shown in **Illustration 15**. Torsion bars are marked "left" and "right".

**27)** Slide the torsion bar rearward through the torsion bar crossmember while holding the adjustment arm in the proper position. Verify that reference marks on adjustment arm and torsion bar match.

**28)** Install the Universal Torsion Bar Unloading Tool (J 36202). Again, be very careful when increasing tension on torsion bar.

**29)** Install retainer plate and adjusting bolt. Thread in adjusting bolt until exposed length is at measured length taken during disassembly. This way, the bars will be installed in their stock position.

**30)** Have brake system bled by a certified brake technician.

**31)** Install front wheels and lower vehicle to the ground. Tighten lug nuts.

**32)** When vehicle is at proper ride height (**Refer to Step 12 of Rear Installation**), torque the lower control arm to front and rear crossmember pivot nuts to 175 ft. lbs., starting from the front to the rear.



**33) Install existing sway bar to lower control arm using Sway Bar Extension (20-833739) and hardware provided (**Illustration 16**). Torque Button Head Bolts to 66 ft. lbs.**

**Illustration 16**

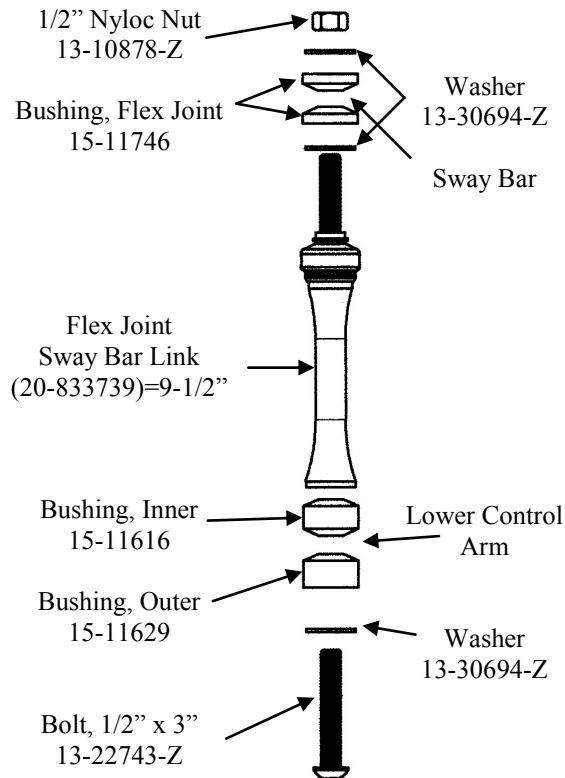

**IMPORTANT NOTICE TO INSTALLER**

When installing the **RCD** Flex Joint sway bar links, this hole **MUST** be drilled out to a minimum of 5/8" and a maximum of 3/4", which is recommended, and edges ground smooth. Failure to do so may result in shearing off of attaching bolt.

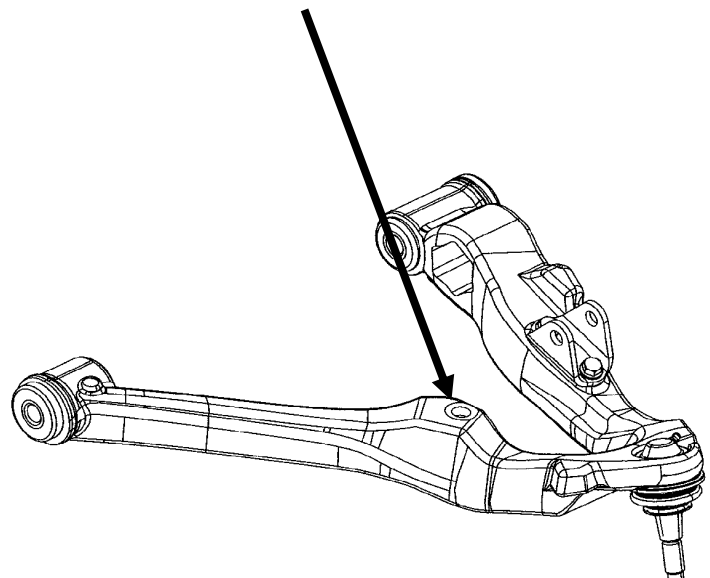

## **REAR INSTALLATION**

- 1) Raise the vehicle. If working without a shop hoist support vehicle with suitable safety stands. To do this put vehicle in gear, block front wheels, both in front and behind tires, then disengage emergency brake. Place floor jack underneath rear axle and raise vehicle. Place suitable safety stands under frame to support vehicle and lower vehicle onto safety stands.
- 2) With the floor jack, raise the rear axle enough to relieve tension on the shock absorbers and remove them.
- 3) Remove rear U-bolts attaching rear axle to driver side leaf spring. Carefully lower rear axle.

**WARNING:** Do not allow axle to hang by any hoses or cables.

4) Secure the spring assembly together with suitable "C-clamps" (**Illustration 17**). Remove any spring leaf alignment clamps. Remove the spring center bolt. A hammer and drift punch may be used to drive bolt out if necessary.

5) Carefully remove "C-clamps" and set the helper spring aside if installed.

**NOTE:** Add-a-Leaf (13-70039-1) will be placed in the spring assembly progressively according to length. For example, if two existing leaves are 32" long and the next is 25" long, and the new Add-a-Leaf is 28" long, place the Add-a-Leaf between the existing leaves.

6) Apply a small amount of grease to each end of the Add-a-Leaf, place it in the spring assembly as described in the note above and assemble the leaf spring using the "C-clamps."

7) Insert new Center Pin (13-90750) and nut. Torque to 20 ft. lbs.

**CAUTION:** Do not try to compress the spring with the center pin.

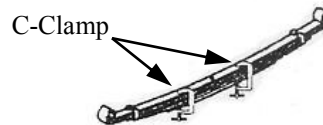

Secure spring assembly together with suitable C-Clamps. Remove spring center bolt. Remove C-Clamps and Insert Add-A-Leaf.

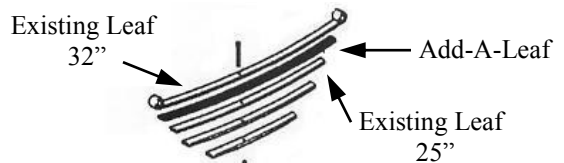

Position Add-A-Leaf in spring pack progressively according to length. EX: Two existing leaves are 32" & 25" so place 28" Add-A-Leaf between existing leaves.



Do not install Add-A-Leaf below a Helper Spring



Install C-Clamps then Center Bolt. Do not attempt to pull springs together with Center Bolt.

### **Illustration 17**

**8)** Insert new riser Block (20-830671) on axle pad. Make sure the block's pin indexes into the hole of the axle housing spring pad. The short end of the block faces the front of the vehicle. Carefully raise rear axle until block makes contact with leaf spring. Make sure center bolt is aligned with hole in block (**Illustration 18**).

**9)** Re-mount axle to spring using the new U-bolts (13-90646), Washers, Nuts and existing spring plates. Torque U-bolts nuts to 85-100 ft.-lbs.

**Repeat steps 3 through 9 on opposite side.**

**10)** Install new longer Shock Absorbers (BE5-6137-H5), using the existing hardware attach the shock to lower axle mount and torque nuts to 74 ft. lbs. Attach shock to upper frame mount and torque to 13 ft. lbs.

**11)** Disconnect brake line bracket from differential. In it's place install Brake Line Extension (20-51089-13) to differential using original hardware previously removed. Attach brake line to extension using 5/16" hardware provided.

**12)** Remove existing rear bumpstops from bottom of frame rails.

**13)** Install new Rear Bumpstop (15-11031) and Rear Bumpstop Extension (20-51089-12) as an assembly to frame rail at each of the original bumpstop locations. Secure with 7/16"-14 x 1-1/4" hardware provided.

**14)** Install rear wheels and lower vehicle.

**15)** Once vehicle is supporting it's own weight, adjust ride height (**Illustration 1**).

**NOTE:** To attain ride height add the lift kit height to the original ride height measurement previously taken in "GETTING STARTED." Example: Original ride height of 21" plus 6" for lift kit height, equals 27" for proper ride height measurement. On this example vehicle adjust torsion bar to achieve ride height of 27." Manually bounce the front and rear of vehicle to pro-set the bar and springs. Then, evenly adjust the torsion bar bolts until the front of the vehicle spindle-to-top offender well measurement achieves proper ride height.

**NOTE:** Each torsion bar may require slightly different adjustment to level vehicle side to side.

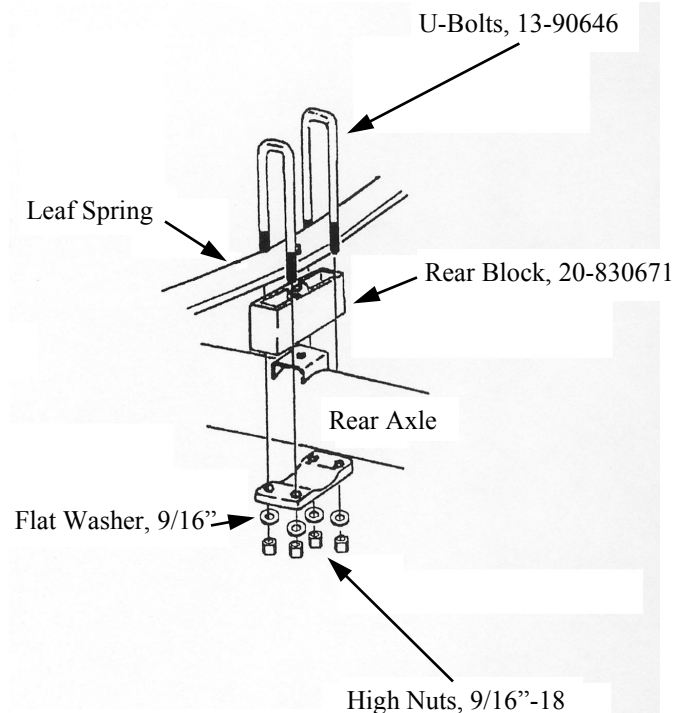

**Illustration 18**

**16)** Check that all fasteners are secured on both front and rear of vehicle. Turn steering to full left, then full right and check for proper clearance.

**SOME FINAL NOTES**

- ❑ After installation is complete, double check that all nuts and bolts are tight. Refer to the torque specifications chart on last page.
- ❑ If new tires were installed that are more than 10% taller than original tires, the speedometer must be recalibrated for the Rear Wheel Anti-Lock Brake System to function properly. Contact an Authorized GM dealer for details on recalibration.
- ❑ With vehicle on the floor, cycle steering lock to lock and inspect steering, suspension and driveline systems for proper operation, tightness and adequate clearance. Recheck brake/hose fitting for leaks. Be sure all hoses are long enough.
- ❑ Have headlights readjusted to proper setting.
- ❑ Have front end aligned to factory specifications. Be sure vehicle is at desired ride height prior to realignment.

**TORQUE SPECIFICATIONS**

5/16" NUTS	20 FT. LBS.	M6	9 FT. LBS.
3/8" NUTS	35 FT. LBS.	M8	23 FT. LBS.
7/16" NUTS	60 FT. LBS.	M10	45 FT. LBS.
1/2" NUTS	90 FT. LBS.	M12	75 FT. LBS.
9/16" NUTS	160 FT. LBS.	M14	120 FT. LBS.
5/8" NUTS	175 FT. LBS.	M16	165 FT. LBS.

**EXISTING HARDWARE TORQUE SPECIFICATIONS**

CALIPER ALLEN HEAD BOLT	38 ft. lbs.
FR. BRAKE ANCHOR PLATE TO KNUCKLE	210 ft. lbs.
LOWER CONTROL ARM NUTS	121 ft. lbs.
UPPER CONTROL ARM NUTS	140 ft. lbs.
TIE ROD NUTS	46 ft. lbs.
FRONT SHOCK NUTS (upper & lower)	66 ft. lbs.
REAR SHOCK NUTS (upper)	13 ft. lbs.
REAR SHOCK NUTS (lower)	74 ft. lbs.
LOWER BALL JOINT NUTS	94 ft. lbs.
UPPER BALL JOINT NUTS	74 ft. lbs.
DIFFERENTIAL SUPPORT BOLTS 10MM	45 ft. lbs.