

# EG4 LITHIUM-ION BATTERY USER MANUAL

- 2 -

## MANUAL OVERVIEW

### ► CONTENT

The EG4 series of Lithium iron phosphate battery modules are designed for Telecom and energy storage applications. The battery modules include an integrated, intelligent Battery Management System (BMS) that monitors, manages, and logs all individual battery cell parameters, such as voltage, current, temperature, capacity, cell balancing, and state of health for operator safety and module protection.

This product user manual describes the type, size, and structure of the battery modules including BMS characteristics and module installation details.

#### CHAPTER CONTENT

1. Overview  
Background, Applications and Advantages
2. Principle and Structure  
Operating principles and connecting structures
3. Parameters  
All battery module parameters and protections
4. Installation and Testing
5. Computer Software  
Installation, connection and communication
6. Shipping, Storage, and Disposal
7. Safety, Symbols, and Cautions

### ● BEFORE YOU START

Read all the safety information provided in this document prior to installing or operating the equipment. Contact Customer Support immediately for a free consultation, if you have any questions about the handling, operation or safe use of the battery.

To handle or operate the battery modules, you shall:

- Be knowledgeable and qualified to perform electrical work
- Read the complete user manual before operating or handling battery modules
- Remove any possible metallic shorting risk from your body, such as jewelry, watches, rings, necklaces, etc.
- All tools shall be insulated

# TABLE OF CONTENTS

<b>1 OVERVIEW.....</b>	<b>4 -</b>
<b>1.1 BACKGROUND AND APPLICATIONS.....</b>	<b>4 -</b>
<b>1.2 ADVANTAGES.....</b>	<b>4 -</b>
<b>2 PRINCIPLE AND STRUCTURE.....</b>	<b>6 -</b>
<b>2.1 OPERATING PRINCIPLE.....</b>	<b>6 -</b>
<b>2.2 CONNECTING STRUCTURE.....</b>	<b>6 -</b>
<b>3 PARAMETERS.....</b>	<b>7 -</b>
<b>3.1 MODELS.....</b>	<b>7 -</b>
<b>3.2 CONTROL PANEL.....</b>	<b>7 -</b>
<b>3.3 BATTERY MANAGEMENT SYSTEM (BMS) .....</b>	<b>10 -</b>
<b>3.3.1 VOLTAGE PROTECTION.....</b>	<b>10 -</b>
<b>3.3.2 CURRENT PROTECTION.....</b>	<b>10 -</b>
<b>3.3.3 TEMPERATURE PROTECTION.....</b>	<b>11 -</b>
<b>3.3.4 CELL BALANCE.....</b>	<b>11 -</b>
<b>3.3.5 BATTERY HEATING AND THERMAL PRESERUATION.....</b>	<b>11 -</b>
<b>4 INSTALLATION AND TESTING.....</b>	<b>13 -</b>
<b>4.1 PREPARE TO INSTALL.....</b>	<b>13 -</b>
<b>4.1.1 INSTALLATION OF ENVIRONMENT.....</b>	<b>13 -</b>
<b>4.1.2 TOOLS AND MATERIALS.....</b>	<b>14 -</b>
<b>4.1.3 SITE SURVEY.....</b>	<b>15 -</b>
<b>4.1.4 BATTERY CHECK.....</b>	<b>15 -</b>
<b>4.2 INSTALLATION.....</b>	<b>15 -</b>
<b>4.2.1 CAUTIONS.....</b>	<b>15 -</b>
<b>4.2.2 INSTALLATION STEP.....</b>	<b>16 -</b>
<b>5 PC SOFTWARE.....</b>	<b>19 -</b>
<b>5.1 PC SOFTWARE.....</b>	<b>19 -</b>
<b>5.1.1 INSTALLATION OF SOFTWARE.....</b>	<b>20 -</b>
<b>5.1.2 CONNECT AND COMMUNICATE.....</b>	<b>20 -</b>
<b>6 SHIPPING, STORAGE, AND DISPOSAL.....</b>	<b>21 -</b>
<b>6.1 SHIPPING AND STORAGE.....</b>	<b>21 -</b>
<b>6.2 WARNING AND DISPOSAL.....</b>	<b>21 -</b>
<b>6.3 COMMON FAULTS AND SOLUTIONS.....</b>	<b>22 -</b>
<b>7 SAFETY, SYMBOLS AND CAUTIONS.....</b>	<b>23 -</b>
<b>7.1 SAFETY SYMBOLS.....</b>	<b>23 -</b>
<b>7.2 PRECAUTIONS.....</b>	<b>23 -</b>

- 4 -

## 1 OVERVIEW

### 1.1 BACKGROUND AND APPLICATIONS

The EG4 series battery modules are the first lithium-ion modules for Telecom and energy storage applications. Lithium-ion batteries are a new generation of “green energy” batteries. In recent years, the rapid advancement of lithium-ion battery technology has accelerated the pace to replace traditional lead-acid batteries. Compared with traditional lead-acid batteries, lithium-ion batteries boast high energy density, small volume, light weight, long life, and a wide temperature range along with other advantages, particularly safety, with the use of lithium iron phosphate (LiFePO<sub>4</sub> or LFP) and intelligent battery management systems. At present, the lithium iron phosphate battery technology is very mature, with the cost gradually declining. It is becoming widely used in mainstream and high-end standby power solutions and home energy storage applications and is the preferred battery technology for communication backup power sources.

## 1.2 ADVANTAGES

1. High performance LFP cells for long life, safety, and a wide temperature range
2. High energy density, small size, light weight, maintenance free, and zero emissions
3. LFP cells are connected with fire retardant wire and copper connecting bus bars for stability and safety
4. Built-in BMS, with battery voltage, current, temperature, and state of health (SOH) management
5. LEDs indicate the battery State of Charge (SOC) and operating status
6. Intelligent cell balancing while charging to ensure consistent battery capacity and extended service life
7. Optional heating function for use in low temperature environments
8. Optional integrated Simple Network Management Protocol (SNMP) communication module to support remote, dynamic battery module monitoring
9. Standard 19 inch metal rack mount battery module enclosure for simple installation
10. Flexible customization of dimensions
11. Easily connect battery modules in parallel for increased capacity

- 6 -

# 2 PRINCIPLE AND STRUCTURE

## 2.1 OPERATING PRINCIPLE

EG4-24V series battery modules are primarily used as standby, storage, or backup energy sources. However, battery modules initially require a charge cycle from some power source (such as utility grid power sources, generators, or solar photovoltaic (PV) systems) to obtain their cycle capacity. They can then provide continuous power to loads when power sources are disrupted or not available; until their capacity is too low to continue the discharge cycle. Once a power source returns, the battery module is recharged and the charge/discharge cycle continues.

## 2.2 CONNECTING STRUCTURE

When using more than one EG4-24V series battery module, it is imperative to use Bus Bars to provide steady and even charging across your battery bank.

- 7 -

# 3 PARAMETERS

## 3.1 MODELS

The EG4-24V series battery module product specifications are in Table 3.1

**TABLE 3.1 EG4-24V SERIES BATTERY MODULE PRODUCTS**

Model Type	Voltage(V)	Capacity	Energy	Length	width	Height	Weight (Kg)
EG4-24V200	25.6	200Ah	5120Wh	442mm	470mm	155mm	43.0

## 3.2 CONTROL PANEL

EG4-24V series battery module is shown in figure 3.2.

## FIGURE 3.2 EC4-48U SERIES BATTERY MODULE

- 8 -

**TABLE 3.3 DESCRIPTIONS**

NO.	Name	Function	Remarks
1	Handle	For carrying and handling	
2	Terminals	Connect to DC bus for charging and discharging	
3	Fixture	Rack mount enclosure	
4	ID	Assign address for each module	See Table 3.4
5	RUN	LED indicates module operation	ON - Standby Flashing - charge/discharge
6	RS485	RS485 Communication interface	
7	Breaker	Switch the module output on/off	Optional
8	ALM	LED indicates Alarm	
9	SOC	The state of charge	4 green LEDs (each designates 25% SOC)
10	DO	Dry contact with optocoupler circuit	Optional
11	Fuse	Easy-to-replace fuses	Optional

**TABLE 3.4 ASSIGNMENT OF ID ADDRESSES**

Code				Address	Assign	Remarks
1	2	3	4			
ON	ON	ON	ON	0	Module 1	
ON	ON	ON	OFF	1	Reserved for Inverter comms	
ON	ON	OFF	ON	2	Module 2	
ON	ON	OFF	OFF	3	Module 3	
ON	OFF	ON	ON	4	Module 4	
ON	OFF	ON	OFF	5	Module 5	
ON	OFF	OFF	ON	6	Module 6	
ON	OFF	OFF	OFF	7	Module 7	
OFF	ON	ON	ON	8	Module 8	
OFF	ON	ON	OFF	9	Module 9	
OFF	ON	OFF	ON	10	Module 10	
OFF	ON	OFF	OFF	11	Module 11	
OFF	OFF	ON	ON	12	Module 12	
OFF	OFF	ON	OFF	13	Module 13	
OFF	OFF	OFF	ON	14	Module 14	
OFF	OFF	OFF	OFF	15	Module 15	

**Note:** In Table 3.4, the Code designates switch positions for a specific module Address (or ID). The switch position denotes a binary coding scheme where "OFF" (up) is "1" and "ON" (down) is "0". For example, "ON

ON ON ON" is binary "0000" or decimal Address "0"; "ON ON OFF ON" is binary "0010" or decimal Address "2"; "ON OFF ON ON" is binary "0100" or decimal Address "4", and so on. This allows encoding in the range of 0~15, which can support up to 16 modules in parallel. If more modules are needed in parallel, please contact Signature Solar; we will design the module to meet your requirements.

- 9 -

**TABLE 3.5 LED INDICATOR DESCRIPTION**

State	Warning/ Normal	RUN	ALM	SOC LED				Definition
				25%	50%	75%	100%	
OFF		OFF	OFF	OFF	OFF	OFF	OFF	All OFF
Standby	Normal	ON	OFF	ON as battery capacity indicates				
	Warning	ON	Flash 2					
	Protection	OFF	ON					
Charge	Normal	Flash 1	OFF					
	Warning	Flash 1	Flash 2					
	Protection	OFF	ON					
Discharge	Normal	Flash 2	OFF					
	Warning	Flash 2	Flash 2					
	Protection	OFF	ON					
BMS failure		OFF	Flash2					OFF

Note: For State of Charge (SOC), each ON LED indicates an increment of 25% SOC.

Note: Flash 1——Flash once every 1.2S; Flash 2——Flash once every 2.4S.

**TABLE 3.6 COMMUNICATION INTERFACE DEFINITION FOR FRONT PANEL RJ45 CONNECTORS**

Definition	RJ45B (most common)							
	PIN-1 WHT/ORG	PIN-2 ORG	PIN-3 WHT/GRN	PIN-4 BLU	PIN-5 WHT/BLU	PIN-6 GRN	PIN-7 WHT/BRN	PIN-8 BRN
CAN								
RS485							D+	D-
Battery								
Comm								

**FIGURE 3.7 INTERFACE ON BATTERY PANEL**

### 3.3 BATTERY MANAGEMENT SYSTEM BMS

### **3.3.1 VOLTAGE PROTECTION**

#### **● Over Voltage**

While charging, if any individual cell voltage exceeds the cell protection limit or if the battery module voltage exceeds the module protection limit, the BMS will disconnect the battery module terminals to shut off charging. Once all cell voltages and the battery module voltage have decreased below the set recover limits, the BMS will automatically reconnect the battery module terminals and allow charging to resume. The voltage settings are shown in table 3.6.

#### **● Under Voltage**

While discharging, if any individual cell voltage is below the cell protection limit or if the battery module voltage is below the module protection limit, the BMS will disconnect the battery module terminals to shut off discharging. Once all cell voltages and the battery module voltage have increased above the set recover limits, the BMS will automatically reconnect the battery module terminals and allow discharging to resume. The voltage settings are shown in table 3.6.

### **3.3.2 CURRENT PROTECTION**

#### **● Charge Over Current**

While charging, if the current exceeds the maximum continuous current rating by 2% and remains for greater than 10 seconds, or if the current exceeds the rating by 20% and remains for greater than 3 seconds, the BMS will disconnect the battery module terminals to shut off charging. The BMS will automatically reconnect the battery module terminals and allow charging to resume after 180 seconds. Resolve the fault condition to avoid further shutdowns or the BMS will lock the module after 5 attempts and require a manual reset. The settings are shown in table 3.6.

#### **● Discharge Over Current**

While discharging, if the current exceeds the maximum continuous current rating by 2% and remains for greater than 10 seconds, or if the current exceeds the rating by 50% and remains for greater than 3 seconds, the BMS will disconnect the battery module terminals to shut off discharging. The BMS will automatically reconnect the battery module terminals and allow discharging to resume after 60 seconds. Resolve the fault condition to avoid further shutdowns or the BMS will lock the module after 5 attempts and require a manual reset. The settings are shown in table 3.6.

#### **● Short Current Protection**

While discharging, if the current exceeds the maximum continuous current rating by 100% and remains for greater than 1 second, the battery module output circuit breaker will trip and disconnect the battery module terminals to shut off discharging. The BMS will require a manual reset. Resolve the fault condition to avoid further shutdowns. The settings are shown in table 3.6.

#### **● Reverse Polarity Protection**

If the battery module terminals are connected to a load or source with the polarity of the terminals reversed, the BMS will immediately disconnect the battery module terminals and enter the polarity protection state to protect the battery module from damage. The BMS will require a manual reset. Ensure the terminal polarity error is corrected before proceeding.

### **3.3.3 TEMPERATURE PROTECTION**

#### **● Cell**

There are several thermal sensors to monitor cell temperature. If the temperature of any cell is less than 23F or greater than 158F, the BMS will disconnect the battery module terminals to terminate charging. The BMS will automatically reconnect the battery module terminals and allow charging to resume after the temperature returns to within 32F to 140F.

If the temperature of any cell is less than -4F or greater than 167F, the BMS will disconnect the battery module terminals to terminate discharging. The BMS will automatically reconnect the battery module terminals and allow discharging to resume after the temperature returns to within 14F to 149F. The settings are shown in table 3.6.

● PCB

A thermal sensor exists to monitor the printed circuit board (PCB) temperature. If the PCB temperature exceeds 221F, the BMS will disconnect the battery module terminals. The BMS will automatically reconnect the battery module terminals once the temperature is less than 176F. The settings are shown in table 3.6.

● Module

A thermal sensor exists to monitor the battery module ambient temperature. If the ambient temperature is less than -13F or greater than 158F, the BMS will disconnect the battery module terminals. The BMS will automatically reconnect the battery module terminals once the temperature returns to within 5F to 140F. The settings are shown in table 3.6.

### 3.3.4 CELL BALANCE

● Smart Cell Balance

While charging, if any cell voltage exceeds 1.95V and the voltage difference between the cells becomes greater than 20mV, the BMS will initiate the balancing process for those cells. The balance current is based on the cell voltage differences and limited to 200mA.

**TABLE 3.7 PARAMETER SETTING**

NO.	Type	Function	Setting Value	Remarks
1	Voltage	Charge	Charge voltage range	27.6V~28.8V 28V Recommended
			Cell voltage protection	1.9V Warning 1.95V Trip 1.73V Recover
			Module voltage protection	29.6V Warning 30V Trip 27.6V Recover
		Discharge	Cell voltage protection	1V Warning 1.3V Trip 1.7V Recover
			Module voltage protection	22.2V Warning 21.6V Trip 24.0V Recover
2	Current	Charge	Normal 100A Max continuous	
		Discharge	Normal 100A Max continuous 30A recommended	
			Over current protection 1	102.0A Trip 10s delay 60s Recover
			Over current protection 2	150.0A Trip 3s delay 60s Recover
		Short protection		250.0A Trip 1s delay Manual reset
3	Temperature	Cell	Temperature Protection ≤23F or ≥158F Trip Charging -4F or ≥167F Trip Discharging	32F~140F Recover Charging 14F~149F Recover Discharging
		PCB	≥221F Trip	≤176F Recover

		Module		$\leq -13F$ or $\geq 158F$ Trip Ambient	$5F \sim 140F$ Recover Ambient
--	--	--------	--	--	-----------------------------------

# 4 INSTALLATION AND TESTING

## 4.1 PREPARING TO INSTALL

- Rules Of Safety

The installation, operation, and maintenance of EG4-24V lithium iron phosphate battery modules shall be performed by trained and qualified professional personnel. Before installation or use, please read the product safety precautions and related operating instructions. Strictly abide by the following safety rules and any local safety regulations, otherwise personal injury or damage to the product may occur.

1. Ensure any source or load connected to the battery module terminals are in good condition and free from defects.
2. Before installation, ensure all grid power sources are shut down, the battery module output circuit breaker is "OFF" and the battery module is switched "OFF".
3. All electrical wires shall have the same grade of insulation. Also ensure electrical wires are free from nicks, cuts, or exposed metal.
4. Ensure the battery module and associated equipment have reliable and secure grounding affixed.

### 4.1.1 INSTALLATION ENVIRONMENT

The installed battery module environment requires specific parameter ranges for safe, long-term operation. The environmental requirements are shown in table 4.2.

**TABLE 4.2 ENVIRONMENTAL REQUIREMENTS**

Type	Requirement
Working Ambient Temperature Range	$-13F \sim 158F$
Storage Ambient Temperature Range	$-13F \sim 158F$
Relative Humidity	$\leq 95\%$
Atmospheric Pressure Range	$86kPa \sim 106kPa$
Site Environment	No conductive dust, corrosive gas, or vibration. Keep away from heat and flame.

### FIGURE 4.1 INSTALLATION PROCESS

### 4.1.2 TOOLS AND MATERIALS

Suggested items for installation are shown in table 4.3.

**TABLE 4.3 TOOLS AND MATERIALS**



Name	Name
user manual	diagonal cutter
screwdriver	multimeter
wrench	ammeter
wire stripper	insulation tape
	clamps

### 4.1.3 SITE SURVEY

- Equipment Inspection

1. Ensure loads and sources connected to the battery module terminals are in good condition and free from defects.
2. Ensure source voltages will not exceed the battery module charge voltage range shown in table 3.6, charge voltage range.
3. Ensure source currents will not exceed the battery module normal charge current limit shown in table 3.6, normal charge current.
4. Ensure total load currents will not exceed the battery module normal discharge current limit shown in table 3.6, normal discharge current.

- Ground Check

Check if the battery module and associated equipment have reliable and secure grounding affixed.

### 4.1.4 BATTERY CHECK

1. Check the battery module packaging for damage before proceeding; provide documentation if any damage is found (such as purchase receipts, shipping receipts, pictures, videos, et cetera).
2. Check the battery module packing list to ensure all components and accessories are present.
3. Carefully unpack the battery module and check for any damage before proceeding; provide documentation if any damage is found (such as purchase receipts, shipping receipts, pictures, videos, et cetera).
4. Be careful while handling battery modules to avoid any damage or injury.

## 4.2 INSTALLATION

### 4.2.1 CAUTIONS

Battery module installation requires attention to critical details, such as:

1. Installation space and load bearing limits. Ensure there is sufficient space for air flow around the battery module(s); mounting brackets are affixed securely between the battery module(s) and a structural frame to prevent vibration; and the hardware and structural components are capable of supporting the battery module(s) combined weight.
2. Wire specifications. Ensure all source and load wires connected to the battery module(s) are of sufficient temperature rating and wire gauge (or cross-sectional area) to accommodate the battery module(s) maximum continuous operating current and intermittent fault current.
3. Project layout. Ensure the entire construction layout of cables, wiring, source/load equipment, fuses, switches, enclosures, and battery module(s) is reasonable and allows for maintenance activities.
4. Wiring layout. Ensure all wires and cables are routed neatly and securely, without kinks or against abrasive/sharp edges; also consider the benefits of moisture-proofing and corrosion prevention.
5. At least two people should perform the battery module installation for reasons of safety.

**CAUTION:** Ensure the installation site is safe before proceeding.

## 4.2.2 INSTALLATION STEP

Battery installation steps are shown in table 4.4.

**TABLE 4.4 INSTALLATION STEPS**

Step NO.	Name	Definition
1	Power sources	All electrical sources and battery modules shall be turned off. Ensure there are no voltages present before proceeding.
2	Mechanical installation	1. Enclosure and mounting connections 2. Battery mounting connections
3	Electrical installation	1. Grounding wire connection 2. Battery module connections 3. Source/Load connections 4. Communication cable connection
4	Electrical commissioning	Turning on the system

### ● Step 1. Power Sources

Before installation, ensure all grid power sources are turned off and tagged. Turn off all battery modules and disconnect all loads. Ensure there are no voltages present before proceeding.

### ● Step 2. Mechanical Installation

1. Mounting brackets. Ensure mounting brackets are attached on both sides of the battery module enclosure. If they are not attached, locate the mounting brackets and hardware within the shipment packaging and connect a mounting bracket to each side of the battery module enclosure using the provided hardware. Ensure the mounting brackets are attached securely and not loose.

2. Battery module(s). The preferred method to mount battery modules is within a standard 19 inch rack or cabinet. The battery module handles, attached to the front, are used to lift the battery module onto the rack supporting plate then push the battery module into the rack until the battery module mounting brackets touch the rack frame. Then attach mounting bolts through the battery module mounting bracket to the corresponding rack frame mounting nuts. Ensure the mounting brackets fit firmly against the rack frame then tighten the bolts to 6 Foot Pounds.

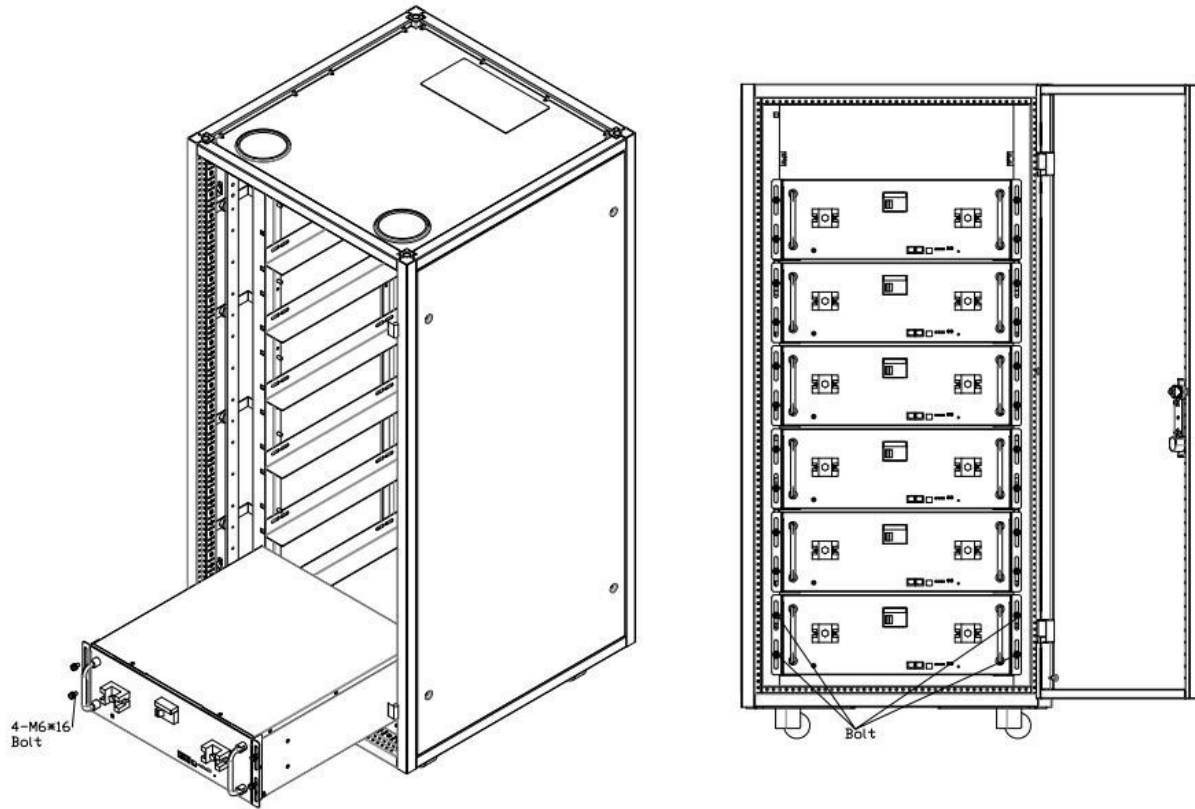

### ● Step 3. Electrical Installation

1. Grounding wire. Affix a grounding wire of sufficient wire gauge from the battery module enclosure grounding screw (located on the front panel) to the rack frame (or cabinet) earth ground point. Ensure the connection is secure and corrosion free.
  2. Battery module(s). With only a single battery, connect the battery module terminals directly to the source or load; ensure proper polarity of connections. If there are multiple batteries to be connected in parallel, ensure that all battery module output voltages are within 0.1 Volt (100 milliVolts) before proceeding. If battery module outputs are not within 0.1 Volt (100 milliVolts), charge the respective battery modules until they are. Then ensure all battery modules are turned off before connecting each battery module "+" (positive) and "-" (negative) terminal to its respective rack "+" (positive) and "-" (negative) bus-bar, using the large gauge connecting wire provided.
  3. Source/Load. Connect all sources and loads to the rack bus bar, observing proper polarity. NOTE: there may be fuses, contactors, switches, etc. between the rack bus bar and the connected sources and/or loads.
  4. Communication cable. If a single battery is used, skip this step.
- When multiple batteries are connected in parallel, set the battery module Address (or ID) of each battery module according to table 3.4 (also ensure no duplicate address codes are used). Then connect one end of the provided RJ-45 communication cable into a battery module front panel RJ-45 jack (labeled "Battery-Comm") and connect the remaining end of the RJ-45 communication cable into another battery module front panel RJ-45 jack (labeled "Battery-Comm"). Continue connecting communication cables until all battery modules are connected. To monitor the battery module parameters, connect a computer to the "RS485" jack using a USB to serial converter/adaptor according to Table 3.6 and Chapter 5.

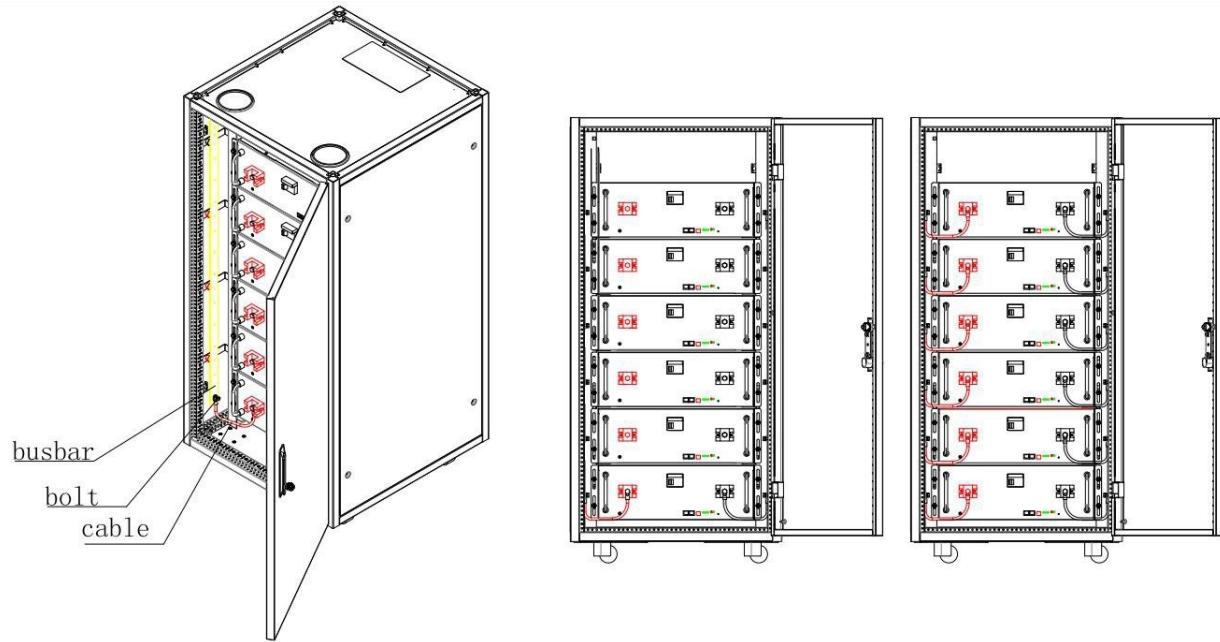

- **Step 4. Electrical Commissioning**

After all previous steps have been completed, turn ON each battery module (including their respective output circuit breaker to ON), one at a time, pausing between each to allow the batteries to stabilize. Continue until all battery modules are ON and terminal voltage is detected on the bus bar. If any battery module does not start, or the front panel "ALM" (alarm) lights, or the output circuit breaker goes OFF, immediately turn OFF all battery modules and disconnect the offending battery module from the rack bus bar and remove it from the rack for further inspection. Once all connected battery modules are deemed functioning properly, then turn ON or enable power sources and loads, one at a time, while monitoring the battery modules, sources, and loads for any anomalies. If any battery module front panel "ALM" (alarm) lights, or any circuit breaker trips, or fuses blow, or arcing, or smoke, immediately turn OFF all battery modules, sources, and loads and correct the fault before proceeding.

Caution : If you have any question about the installation, stop and contact technical support to avoid damage or accidents.

## **5 PC SOFTWARE**

### **5.1 PC SOFTWARE**

- Software Menu

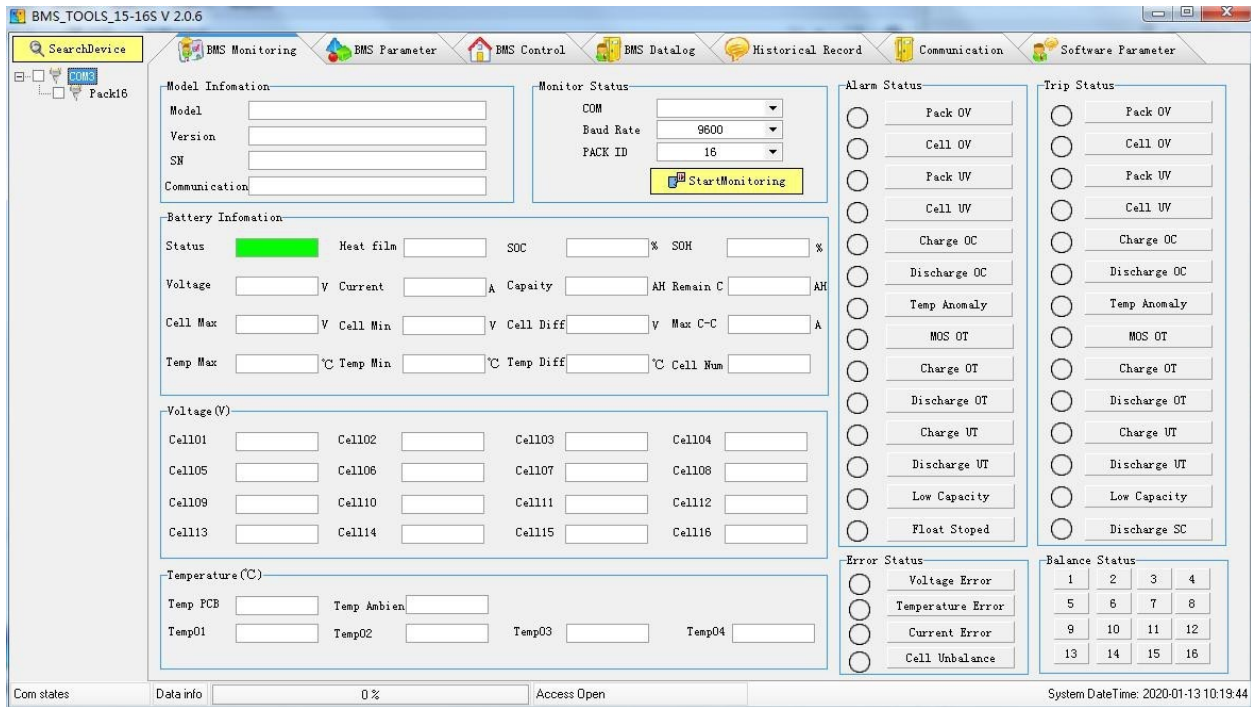

Menu	Explanation
BMS Monitoring	Battery BMS information, display battery data and status
BMS control	Control BMS status
BMS parameter	Check and set battery parameter
BMS Datalog	BMS status storage and export
Historical record	History storage and export
Communication	real-time data, communication with battery BMS
Software parameter	Software settings and Language settings

## 5.1.1 INSTALLATION OF SOFTWARE

Start the software

## 5.1.2 CONNECT AND COMMUNICATE

Unzip the software

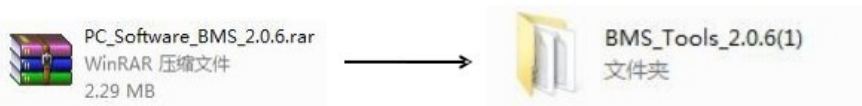

Start the software

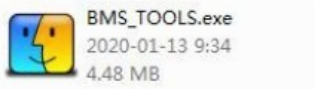

Connect the battery communication port with the communication cable(DB9 interface or RJ45 interface).

Set the baud rate to 9600.

Click "Search Device", and the battery BMS will be online automatically.

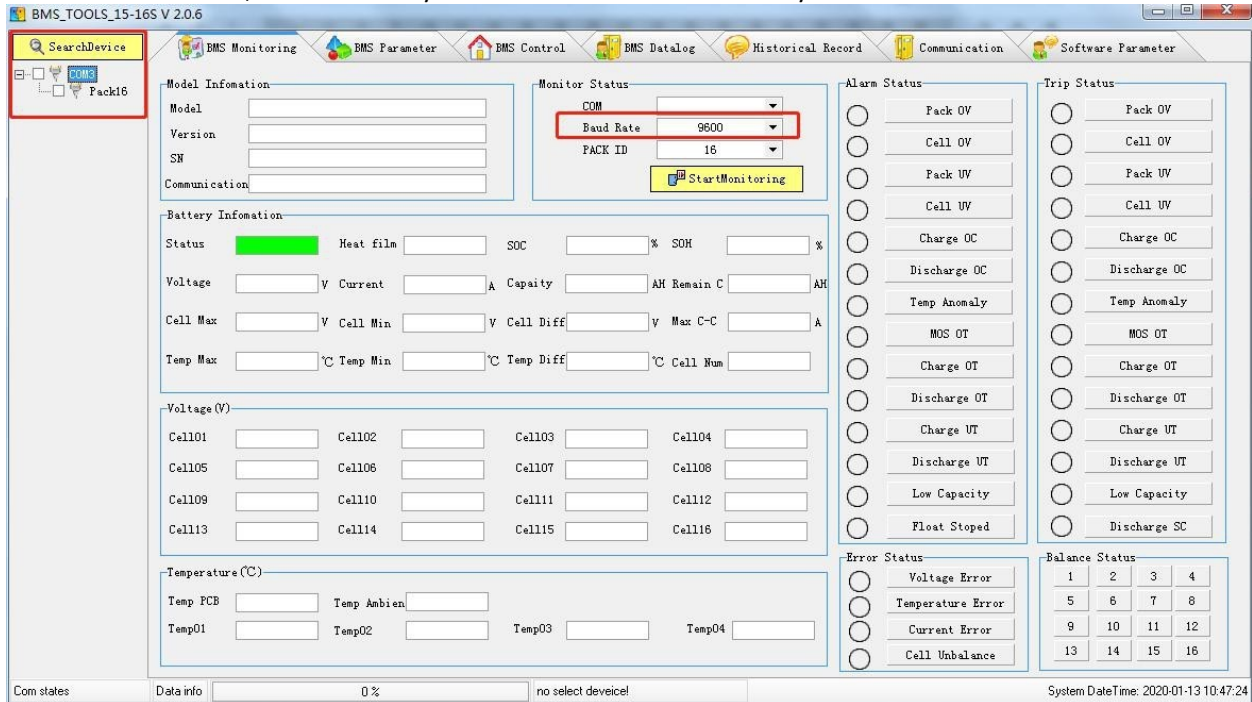

Then all the battery data can be displayed on the PC software.

Menu	Explanation
BMS Monitoring	Battery BMS information, display battery data and status
BMS control	Control BMS status
BMS parameter	Check and set battery parameter
BMS Datalog	BMS status storage and export
Historical record	History storage and export
Communication	real-time data, communication with battery BMS
Software parameter	Software settings and Language settings

## **b SHIPPING, STORAGE, AND DISPOSAL**

### **b.1 SHIPPING AND STORAGE**

#### ● Shipping

According to the provisions of the product can be used in general means of conveyance, but

should avoid throwing, rain fall, strong radiation and corrosion erosion. during transportation, please prevent the collision and strong vibration.

● **Storage**

Storage device in the indoor storage, the ambient air temperature is 32F to + 113F, the average monthly relative humidity of not more than 90%, the ambient air without corrosive and flammable and explosive gas; storage warehouse should be ventilated, free of alkaline, acidic substances and other corrosive gases, without a strong mechanical vibration, shock, and without strong electromagnetic field and direct sunlight. Capacity was maintained at 50% to 60% stores, and charging the battery every 6 months.

## **6.2 WARNING AND DISPOSAL**

When the ALM lights, battery has been alarmed or protected, please check fault reasons and take corresponding measures. Table 5.1 below is the main alarm condition.

**TABLE 5.1 THE MAIN ALARM AND PROTECTION**

State	Type	Indicator	Disposal
Charging	Over voltage protection	ALM	Stop charge, check module voltage and charger
	Over current protection	ALM	Stop charge, check the settings and limitation
	Temperature protection	ALM	Stop charge, wait for the temp recovery
Discharging	Low voltage protection	ALM	Stop discharge, turn to charging mode
	Over current protection	ALM	Stop discharge, check if there is an over load
	Temperature protection	ALM	Stop discharge, wait for the temp recovery

## **6.3 Common Faults And Solutions**

Common faults and solutions are shown in table 5.2.

**TABLE 5.2 COMMON FAULT AND SOLUTION**

NO.	Fault phenomenon	Analysis	Solution
1	No DC output	Low voltage protection	Charge the battery and try again
2	Power supply time is too short	Battery capacity lack or not full power	Maintenance or replacement
3	Battery can not be charged to full	Power system DC output voltage falls below the minimum charge voltage	Regulating DC output voltage of power supply to battery suitable charging voltage
4	ALM LED always lights	Power line connection short circuit	Disconnect the power cable and check all cables
5	The battery output voltage is unstable	Battery management system do not operate normally	Press the reset button to reset the system, then reboot the system
6	Communication lost or data fault	Communication settings fail	Check the communication settings and correct it

Caution : If the battery cannot operate normally, please do not disassemble the battery without technical instructions.

- 23 -

## 7 SAFETY, SYMBOLS AND CAUTIONS

### 7.1 SAFETY SYMBOLS

#### Symbol Definition

DO NOT dispose of battery in a fire.

Recycle or dispose of Lithium batteries in accordance with local Laws/regulations.

DO NOT dispose of battery in the trash.

### 7.2 PRECAUTIONS

Please read and comply with the following conditions of installation and use of the battery, incorrect installation using the battery may cause personal injury or damage to the product.

1. DO NOT throw the battery into water. Store batteries in cool and dry environment when not in use.
2. DO NOT put the battery into fire or heat the battery, so as to avoid explosion or other dangerous events.
3. When charging the battery please choose specialized charging equipment, and follow the correct procedures, do not use unqualified chargers.
4. DO NOT reverse positive and negative terminals, do not connect the battery directly to AC power avoid battery short circuit.
5. DO NOT use batteries from different manufacturers or different kinds, types together ,and do not



mixed use old batteries and new batteries.

6. DO NOT use the battery when it become hot, bulges, deforms or leaks.

7. DO NOT puncture the battery by nail or other sharp objects; Do not throw, stamp on, impact or hit the battery.

8. DO NOT open or try to repair the battery when it is defective. Warranty invalid if the battery repaired or disassembled.

9. Batteries are 75% charged before shipment, Don't use the battery if it's hot, bulged, or smells abnormal and so on, and report to after sale dept. immediately.

10. If you need storage the battery for a long time, please charge and discharge the battery every three months to ensure the best performance, and the best state of charge for storage is between 50%~60%.

11. Please use the battery in the temperature range which defined in the manual.

12. The state of charge of batteries is 50% before shipment, please charge the battery before using.

**NOTE:** If you have some special technical problems which not mentioned above, please contact technical staff at (903) 441-2090.