

Specification for Approval

Product Name : AMOLED Module

Model Name : AMS320FH01-0

Description : 3.2", 240×RGB×400 16M Color

Proposed by			Customer's Approval
Designed	Checked	Approved	

All information contained within this document is strictly private and belongs to the Samsung Mobile Display Co., Ltd. It is to be treated as being marked "Proprietary and Confidential" and is intended only for the recipient(s) to whom it has been sent by us. It may also be legally privileged.

Also, contents in this document are subject to change after prior notice to the customer.

Contents

1. Scope	5
2. Warranty	5
3. Features	6
4. Mechanical specification	6
5. Maximum rating	6
6. Electrical characteristics	7
7. Electro-optical characteristics	8
8. Input/Output terminal	11
8-1. I/O Connection	11
8-2. Circuit Block Diagram	12
9. Recommended Operating Sequence	13
9-1. Power Input Sequence	13
9-2. Power On/Off Sequence	14
9-3. Power Setting Sequence	15
9-4. Initializing Sequence	16
9-5. RAM Address Set	17
9-6. Display On/Off Sequence	17
9-7. Stand-by / Wake-up Sequence	18
10. MDDI I/O DC/AC Characteristics	19
10-1. Receiver Electrical Specifications	19
10-2. Transmitter Electrical Specifications	19
10-3. Data / STB Timing	20
10-4. Reset Input Timing	20
11. Quality Level	21
11-1. Environment Condition	21
11-2. Sampling Procedure	22
11-3. Inspection Item(Cosmetics)	23

SAMSUNG MOBILE DISPLAY CO., LTD.(All Rights Reserved).

12. Reliability	25
12-1. Items of Reliability	25
13. Handling Precautions	27
13-1. Mounting Method	27
13-2. Caution of AMOLED Handling and Cleaning	27
13-3. Static Charge	27
13-4. Safekeeping	28
13-5. Caution for Operation	28
13-6. Storage	29
13-7. Safety	29
13-8. Employing Limit Sample	29
14. Drawing	30
14-1. Product Drawing	30
14-2. FPCB Drawing	31
14-2-1. Schematic Diagram	32
14-2-2. Electronic Part List	33
14-2-3. Placement (Rear)	34
14-3. FPCB Structure	35
14-4. FPCB Layer Pattern	36
14-5. Packing Drawing	42
14-5-1. Module Marking Rule	43
14-5-2. Inner Box Label	43
14-5-3. Carton Box Label	44

SAMSUNG MOBILE DISPLAY CO., LTD.(All Rights Reserved).

1. Scope

This specification applies to the AMOLED display module that is supplied by SAMSUNG MOBILE DISPLAY Co. Ltd. (hereinafter referred to as "SMD") and whose model name and descriptions are specified on the cover-page.

If any unexpected problems and/or unspecified features occur, SMD shall negotiate in order to reach a solution with the customer.

2. Warranty

SMD warrants that at the time of sale the products will, in all material respects, conform to the then applicable version of this specification and will be free from defects in material and manufacture. SMD further warrants that the products will, with recommended maintenance and without being subjected to extraordinary or abnormal use or abuse (e.g., careless handling, assembling without ESD protection, or repairing without SMD's agreement), remain serviceable for fifteen months from the date that product is produced at SMD. Any modification made to products will void the warranty unless the modifications are approved in writing by SMD in advance of the change.

This exclusion does not apply to normal installation of approved accessories. This warranty shall not apply to equipment that has been (1) improperly installed or installed contrary to instructions; (2) subjected to negligence, accident, vandalism, or disasters such as flood, fire, or war; or (3) damaged through improper operation, maintenance, storage or abnormal use or abuse. **THIS IS THE ONLY WARRANTY GIVEN BY SMD AND IS IN PLACE OF ALL OTHERS.** This warranty supersedes any prior, contrary or additional representations, whether oral or written. SMD DISCLAIMS AND EXCLUDES ALL OTHER WARRANTIES—WHETHER EXPRESS, IMPLIED, OR STATUTORY—INCLUDING ANY **WARRANTY OF MERCHANTABILITY, ANY WARRANTY OF FITNESS FOR A PARTICULAR PURPOSE, AND ANY IMPLIED WARRANTIES OTHERWISE ARISING FROM COURSE OF DEALING, COURSE OF PERFORMANCE, OR USAGE OF TRADE.**

SAMSUNG MOBILE DISPLAY CO., LTD.(All Rights Reserved).

Doc. No.: AMS320FH01-0

TITLE : 3.2" 240×400, 16M AMOLED

Rev. : 0.1

5/44

3. Features

- 1) Display Color : 16M_Color
- 2) Display Format : 240(W)×RGB×400(H) dots
- 3) Interface : MDDI
- 4) Driver IC : LD9034 by LDT
- 5) Polarizer : Hard Coated Glare Polarizer

4. Mechanical Specification

Item	Specifications	Unit
Dimensional outline (Glass)	46.16(W) X 76.58(H) X 1.37(T, typ) (0.3T)	mm
Number of dots	240(W) X RGB X 400(H)	Dots
Active area	41.76(W) X 69.60(H)	mm
Diagonal Inch	3.2	inch
Pixel pitch	0.153(W) X 0.153(H)	mm
Sub pixel size	0.051(W) X 0.153(H)	mm

5. Maximum Rating

Item	Symbol	Min.	Max.	Unit	Note	
Supply voltage	Analog	VCI	-0.3	5.0	VDC	(1),(2)
	I/O	VDD3	-0.3	5.0	VDC	(1),(2)
	OLED	ELVDD	-0.3	6.0	VDC	(3)
		ELVSS	-10	GND+0.3	VDC	-
Signal Input voltage	VIN	-0.3	VDD3+0.3	VDC	(2)	
Operating temperature	Top	-20	65	°C	-	
Operating Humidity	Hop	10	96	%(RH)	-	
Polarizer Surface Hardness	3H				-	
Storage temperature	Tstg	-40	70	°C	-	
Storage Humidity	Hstg	10	90	%(RH)	-	

Note 1) VCI, VDD, VBAT should satisfy the below condition of
 $VBAT > VCI, VDD3 > VSS (GND).$

Note 2) If the supplied voltage exceeds the maximum limitation, LSI can be damaged permanently. Therefore, while operating, it is recommend to use LSI within the maximum electrical limitation.
 If not, LSI can cause decreased reliability or operational problems.

SAMSUNG MOBILE DISPLAY CO., LTD.(All Rights Reserved).

6. Electrical Characteristics

-. Test Conditions : VDD3=2.6V, VCI=2.8V, Vbat=3.8V, VSS=0V, Tamb=25°C unless otherwise specified.

Item		Symbol	Condition	Min.	Typ.	Max.	Unit
Supply Voltage	Analog	VCI	-	2.5	2.8	3.1	V
	I/O	VDD3	-	2.34	2.6	2.85	
	OLED	ELVDD	-	4.55	4.6	4.65	
		ELVSS	-	-5.00	-4.9	-4.80	
Input Voltage	"H" level	VIH	-	0.8*VDD3	-	VDD3	V
	"L" level	VIL	-	VSS	-	0.2*VDD3	
Output Voltage	"H" level	VOH	IOH = 1mA IOL = 1mA	0.8*VDD3	-	VDD3	V
	"L" level	VOL		GND	-	0.2*VDD3	
Leakage Current	Input	ILI	VI=VDD3 or VSS	-1.0	-	+1.0	uA
Supply Current	EL Power - 300cd/m ² Full white condition	IBAT	VBAT=3.8V	-	-	375	mA
Driver IC Current Consumption		IVCI	VCI=2.8V	-	-	10	mA
		IVDD3	VDD3=2.6V	-	-	5	mA
		Istby	EL_ON=LOW VDD3=2.6V VCI=2.8V	-	-	30	uA

SAMSUNG MOBILE DISPLAY CO., LTD.(All Rights Reserved).

7. Electro-optical characteristics

-. Test Conditions: VDD3=2.6V, VCI=2.8V, Vbat=3.8V, VSS=0V, Tamb=25℃ unless otherwise specified.

Item	Symbol	Temp	Condition	Min.	Typ.	Max.	Unit	Note	
Brightness		25℃	Normal (White Mode)	255	300	360	cd/m ²	(1)	
Uniformity		25℃	Normal (White Mode)	80	90	-	%	(2)	
Contrast ratio		C/R	25℃	$\Phi=0^\circ, \theta=0^\circ$		3,400	10,000	-	(3),(4)
Color of CIE coordinate	White	x	25℃	$\Phi=0^\circ \theta=0^\circ$	0.270	0.300	0.330	-	(1),(4)
		y			0.280	0.310	0.340	-	
	Red	x			0.625	0.675	0.725	-	
		y			0.275	0.325	0.375	-	
	Green	x			0.170	0.220	0.270	-	
		y			0.675	0.725	0.775	-	
	Blue	x			0.095	0.145	0.195	-	
		y			0.005	0.055	0.105	-	
Color Gamut		25℃	vs. NTSC	100	-	-	%		
Viewing angle		25℃	Upper/Down/Right/Left CR ratio ≥ 200	@60°					
Life Time		25℃	50% Brightness drop @300cd/m ² , Full White	TBD	-	-	Hr	(5)	

SAMSUNG MOBILE DISPLAY CO., LTD.(All Rights Reserved).

NOTE1) Optical Measuring System

In case of using PR705 (Photo-Research™): Sample Evaluation at Development Lab.

- * Measuring Angle = 90 +/-5°
- * Ambient Illumination = Dark Room (under 5 lux)
- * Measuring Distance = 50 +/-5cm
- * Aperture Size = 1° (Measuring Diameter ≐ 5 mm)

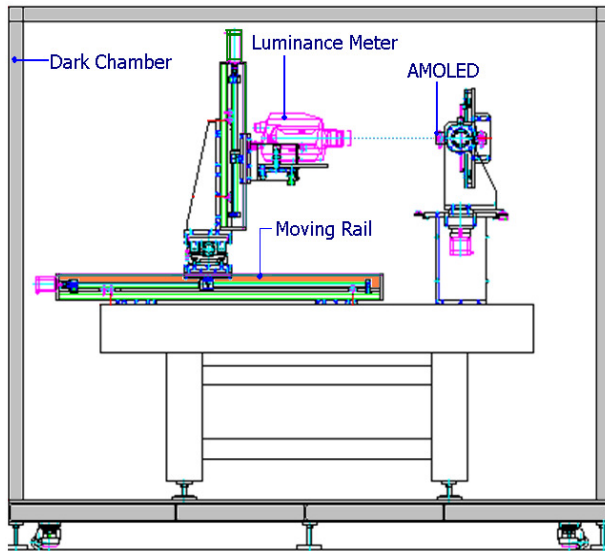

In case of using CA210 (made by Minolta™): MP Inspection at Production Line

- * Measuring Angle = 90 +/- 5°
- * Ambient Illumination = 50~600 lux. (When CA210 is used, ambient illumination do not affect to measuring luminance because CA210's contacting rubber can exclude outside light.)
- * Measuring Distance = 0cm (Contact Measuring)

Note 2) Uniformity Measuring Point

$$\text{Uniformity} = L_{\min} / L_{\max} * 100 [\%]$$

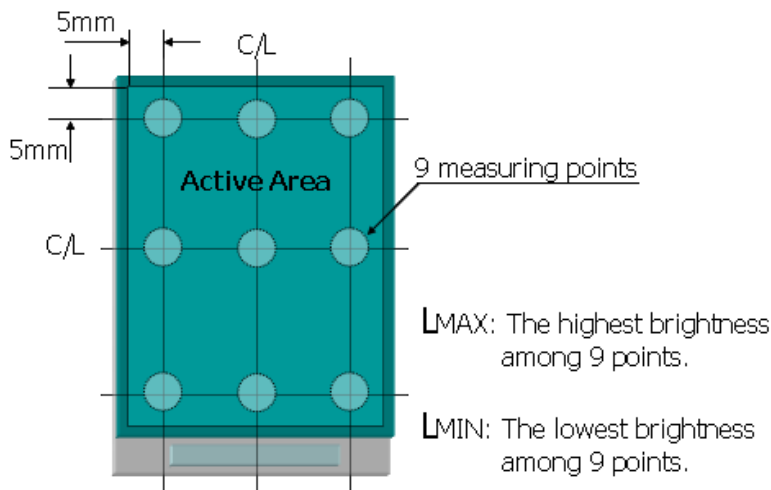

SAMSUNG MOBILE DISPLAY CO., LTD.(All Rights Reserved).

Note 3) Definition of Contrast Ratio(C/R)

$$\text{Contrast Ratio(C/R)} = \frac{\text{Brightness of selected dot (White patterned area) at } 300\text{cd/m}^2}{\text{Brightness of non-selected dot (Black patterned area) at } 300\text{cd/m}^2}$$

Note 4) Definition of ϕ , θ

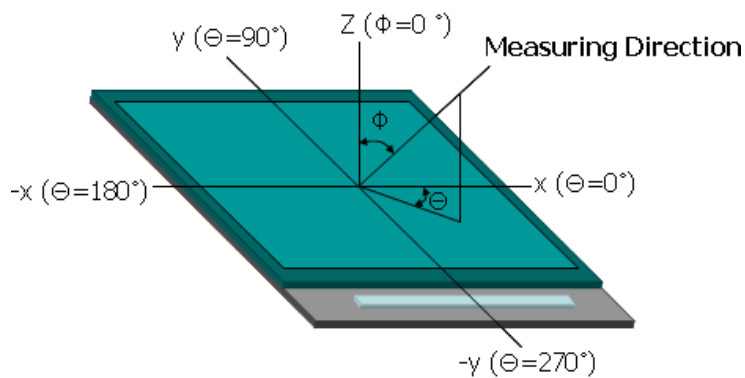

Note 5) Life Time : The elapsed time that the full white brightness decreases to the half of initial value.

8. Input/Output Terminal Assignment

8-1. I/O Connection (44PIN, PANASONIC AXK844145WG)

Pin #	Symbol	I/O	Function
1	TS_LR		Touch Panel LR
2	TS_UL		Touch Panel UL
3	TS_LL		Touch Panel LL
4	TS_UR		Touch Panel UR
5	GND	-	Ground Terminal
6	GND	-	Ground Terminal
7	MSM_MIC_BIAS		Microphone Voltage
8	GND	-	Ground Terminal
9	MIC1_M_A		Microphone M
10	MSN	I	Negative MDDI strobe clock
11	MIC1_P_A		Microphone P
12	VCI	Analog Power	Power Terminal for Analog Power and Internal Logic(2.8VDC)
13	GND	-	Ground Terminal
14	MSP	I	Positive MDDI strobe clock
15	GND	-	Ground Terminal
16	TE	O	Output Signal to eliminate AM-OLED's Tearing Effect
17	KB_C5	-	Keypad Column5
18	GND	-	Ground Terminal
19	KB_C6	-	Keypad Column6
20	RESETB	I	Reset Signal
21	KB_C7	-	Keypad Column7
22	MDN	I/O	Negative MDDI data input/output
23	KB_R2	-	Keypad Row2
24	MTPV	-	Leave it open
25	KB_R5	-	Keypad Row5
26	MDP	I/O	Positive MDDI data input/output
27	KB_R6	-	Keypad Row6
28	EL_ON	O	Module DCDC on/off control signal(VCI level)
29	KB_R7	-	Keypad Row7
30	GND	-	Ground Terminal
31	KB_START_KEY	-	Start Key
32	ELVSS_L	Display Power	Power Pin for Module Analog
33	KB_END_KEY	-	End Key
34	ELVDD_R	Display Power	Power Pin for Module Analog
35	KB_SEND_KEY	-	Send Key
36	VDD3	Logic I/O	Power Terminal for Logic I/O (2.6VDC)
37	GND	-	Ground Terminal
38	ELVSS_R	Display Power	Power Pin for Module Analog
39	N_KP_BL_DRV	-	LED Feedback
40	ELVDD_L	Display Power	Power Pin for Module Analog
41	VREG_5V	-	LED Voltage
42	GND	-	Ground Terminal
43	GND	-	Ground Terminal
44	GND	-	Ground Terminal

SAMSUNG MOBILE DISPLAY CO., LTD.(All Rights Reserved).

8-2. Circuit block diagram

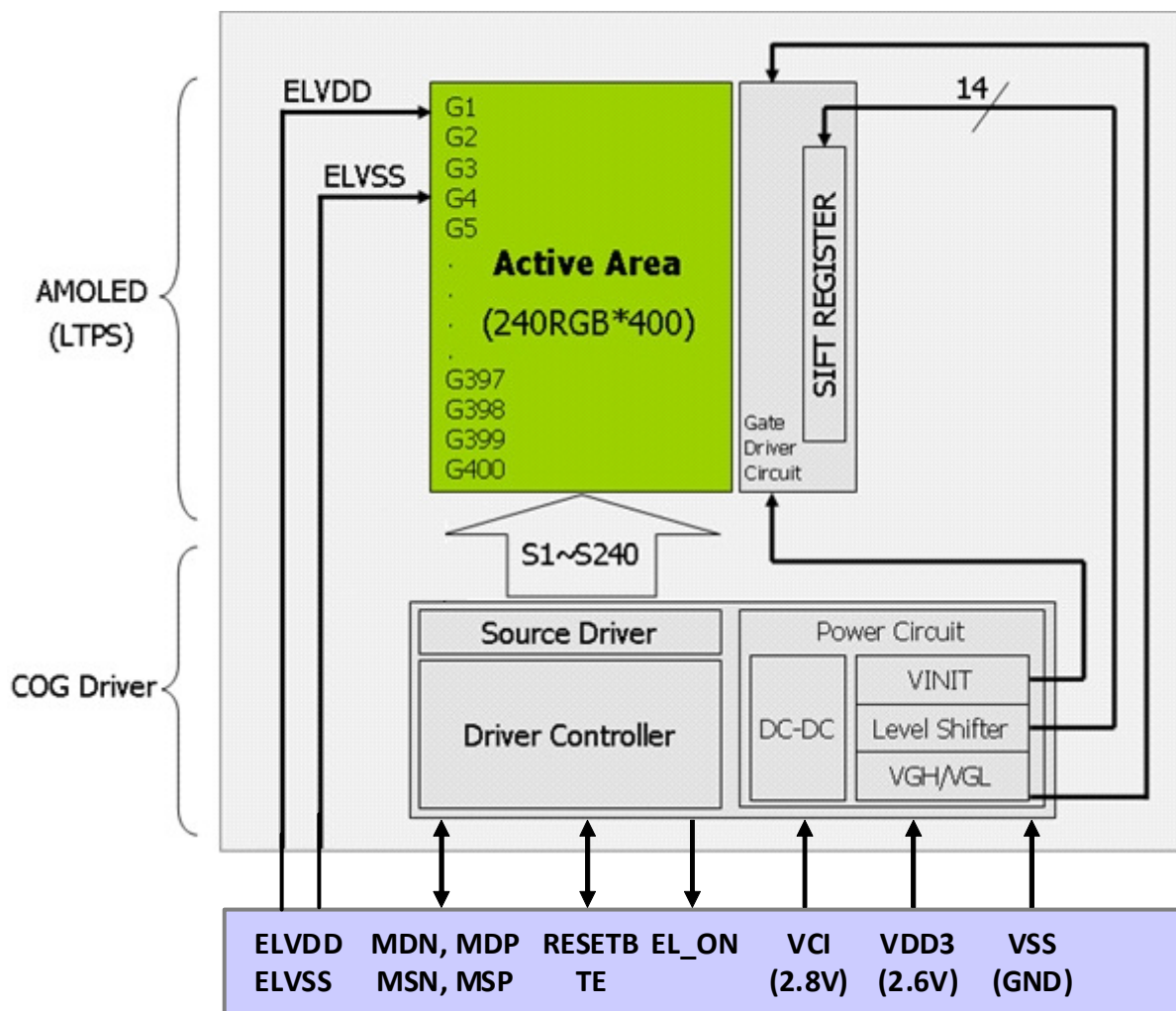

- Note-1) MTPV will be used in AMOLED module assembly factory.
Therefore a user must do not connect any signals or power-lines.
- Note-2) DC-DC IC is located at SET Maker's side.

9. Recommended Operating Sequence

9-1. Power Input Timing

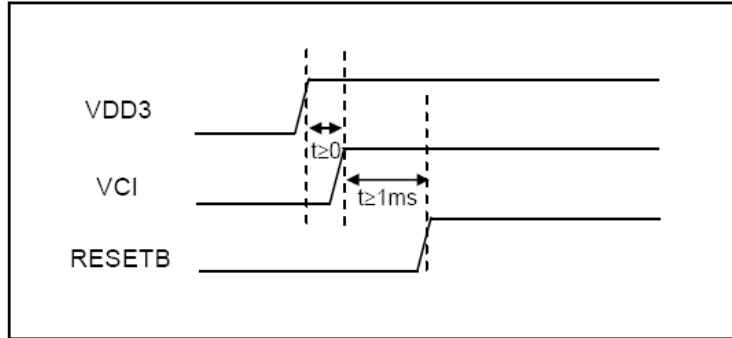

Note-1) VDD3 must be supplied earlier than VCI or at least supplied at the same time with VCI. RESETB must be applied after VCI has been supplied.

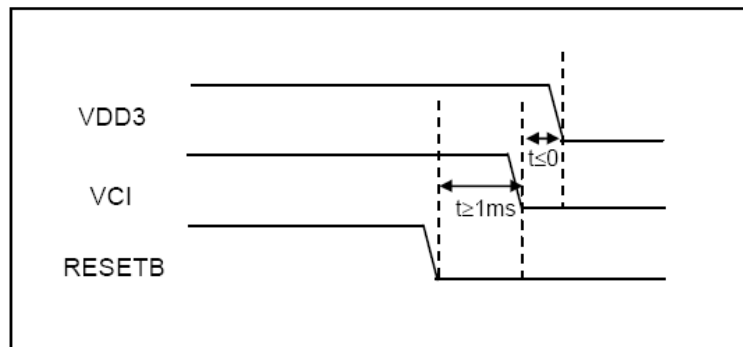

Note-1) VDD3 must be OFFed later than VCI or at least OFFed at the same time with VCI. VCI must be OFFed after RESETB has been pulled down.

9-2 Power On/Off Sequence

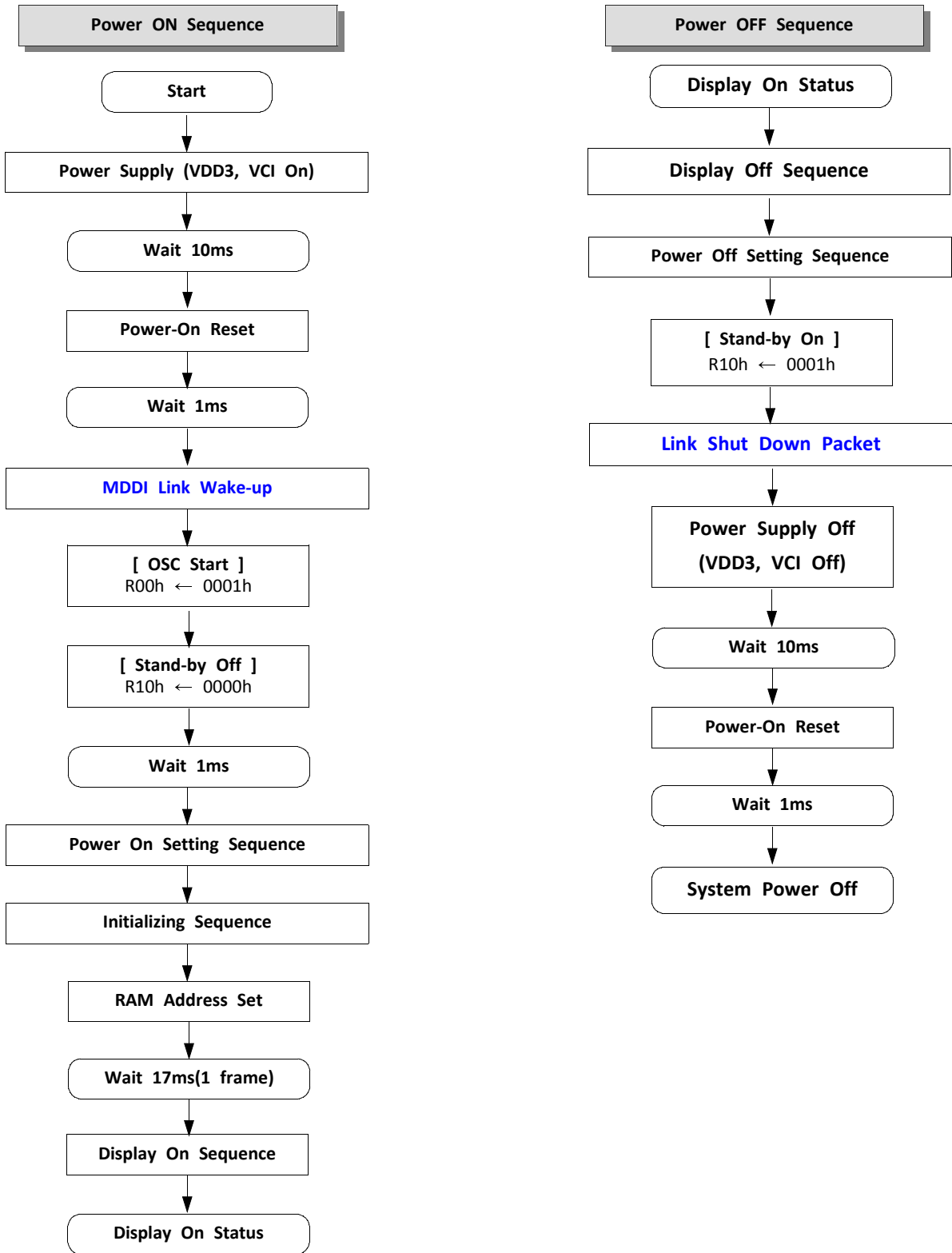

SAMSUNG MOBILE DISPLAY CO., LTD.(All Rights Reserved).

9-3 Power On/Off Setting Sequence

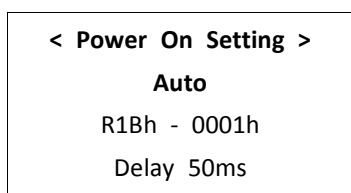
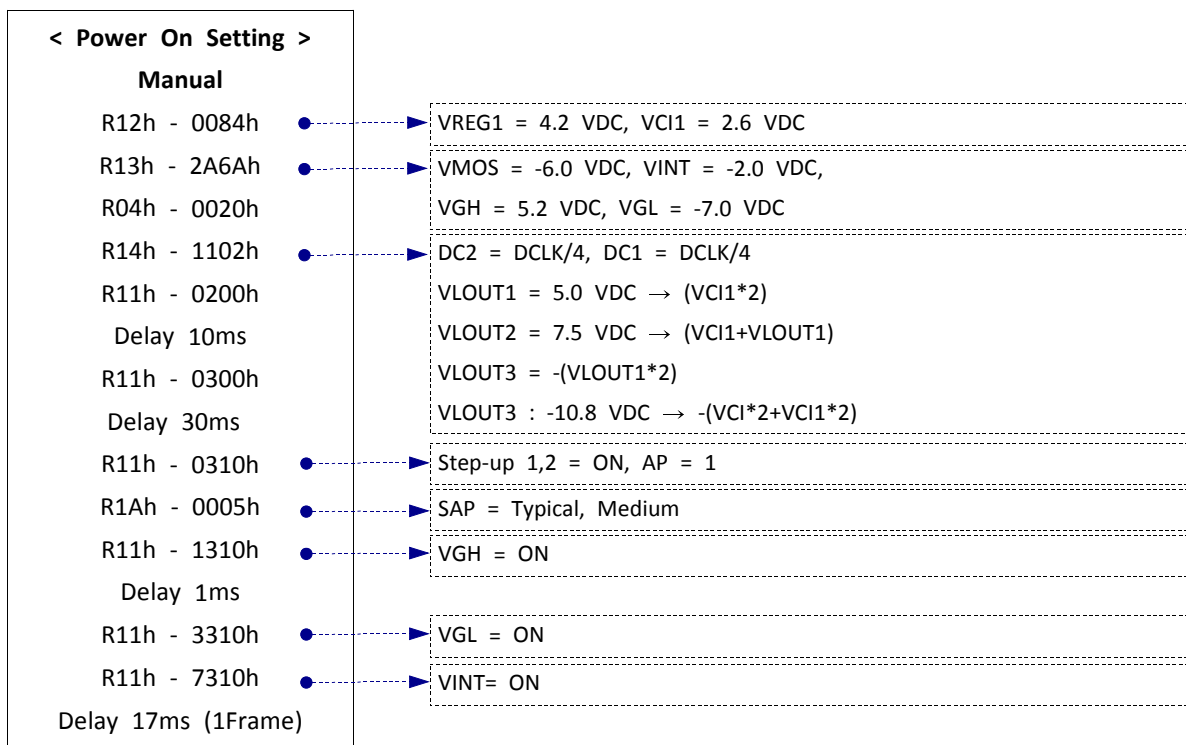

※. SET maker can choose Manual or Auto Power On setting

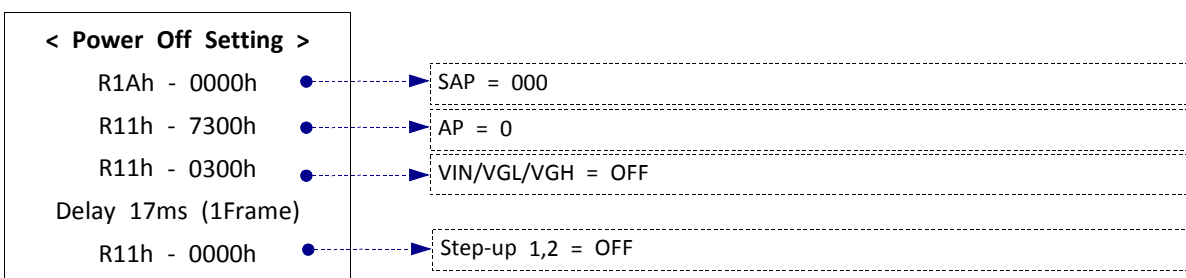

9-4 Initializing Sequence

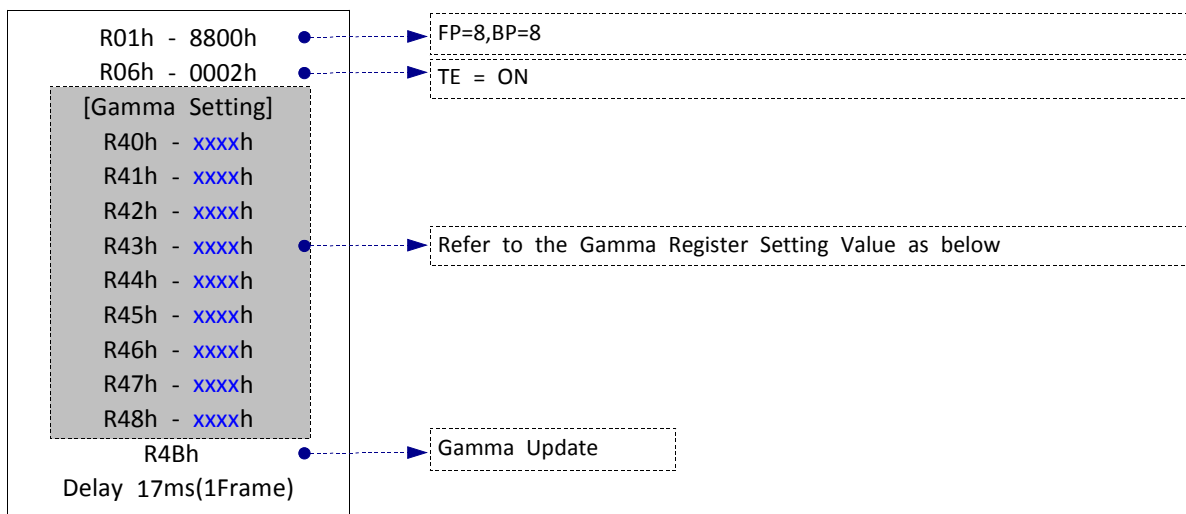

[Gamma Register Setting Value]

Luminance	300cd/m ²	200cd/m ²	175cd/m ²	150cd/m ²	125cd/m ²	100cd/m ²
Register	Parameter	Parameter	Parameter	Parameter	Parameter	Parameter
R40h	5800h	4900h	440Fh	400Fh	3A0Fh	350Fh
R41h	6800h	5700h	5112h	4B12h	4612h	3F12h
R42h	7500h	6200h	5A25h	5525h	4D25h	4725h
R43h	6B62h	6974h	4722h	4521h	3E1Bh	2914h
R44h	507Fh	4F7Fh	2671h	2973h	2774h	2475h
R45h	5654h	5354h	4746h	4948h	4949h	4A49h
R46h	292Ah	2E2Fh	291Fh	291Fh	291Fh	2A21h
R47h	232Fh	2532h	1D2Dh	1B2Eh	1E2Fh	1C31h
R48h	2526h	2828h	2624h	2526h	2726h	2627h

Luminance	70cd/m ²	50cd/m ²	30cd/m ²	10cd/m ²	5cd/m ²
Register	Parameter	Parameter	Parameter	Parameter	Parameter
R40h	2D0Fh	260Fh	1C0Fh	0E0Fh	080Fh
R41h	3612h	2E12h	2410h	1410h	0C10h
R42h	3D25h	3425h	281Fh	161Fh	0E1Fh
R43h	0016h	3E00h	3E00h	3E00h	3E00h
R44h	227Bh	1E01h	2C01h	2C01h	2C01h
R45h	4C45h	4C4Ch	5842h	5842h	5842h
R46h	2B1Eh	2B17h	2D25h	2C22h	2C22h
R47h	1C32h	1E32h	2334h	2537h	2337h
R48h	2728h	2A2Ah	2D2Ch	302Dh	2E2Ch

※ If you want to use other gamma conditions except for above driving conditions, you should ask for us. Otherwise, AMOLED products may occur quality trouble.

SAMSUNG MOBILE DISPLAY CO., LTD.(All Rights Reserved).

9-5 RAM Address Set

[RAM Address Set]
 R20h ← 0000h
 R21h ← 0000h

9-6 Display On/Off Sequence

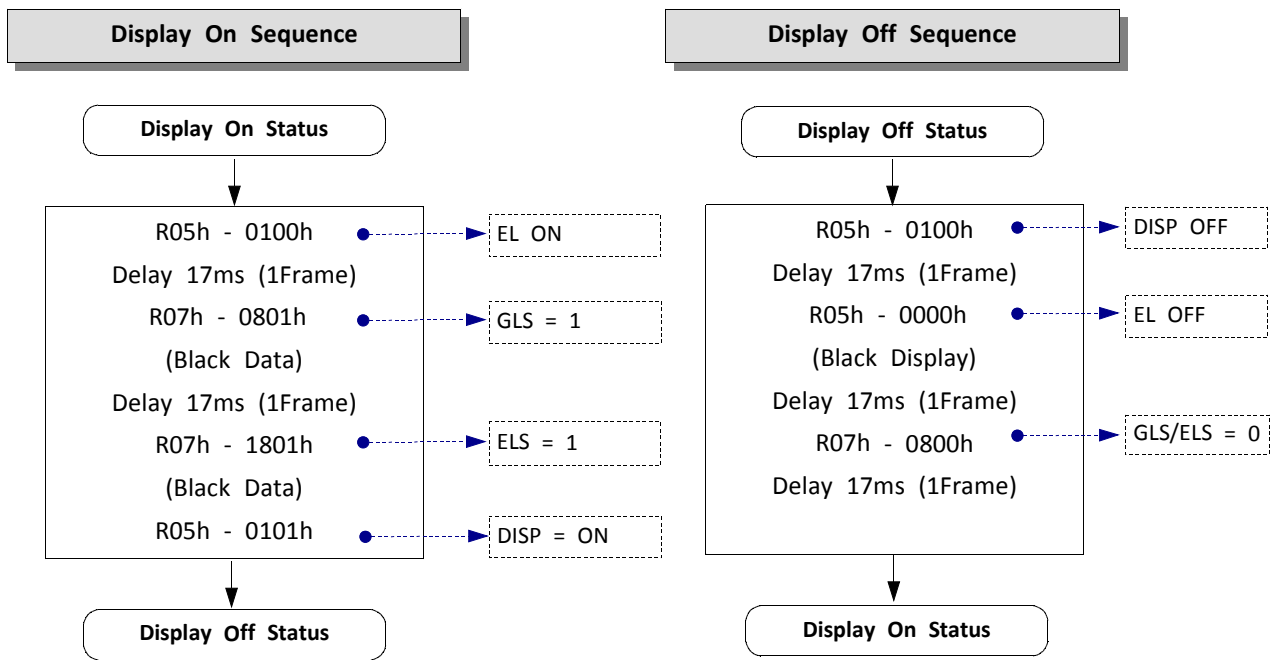

9-7 Stand-by / Wake-up Sequence

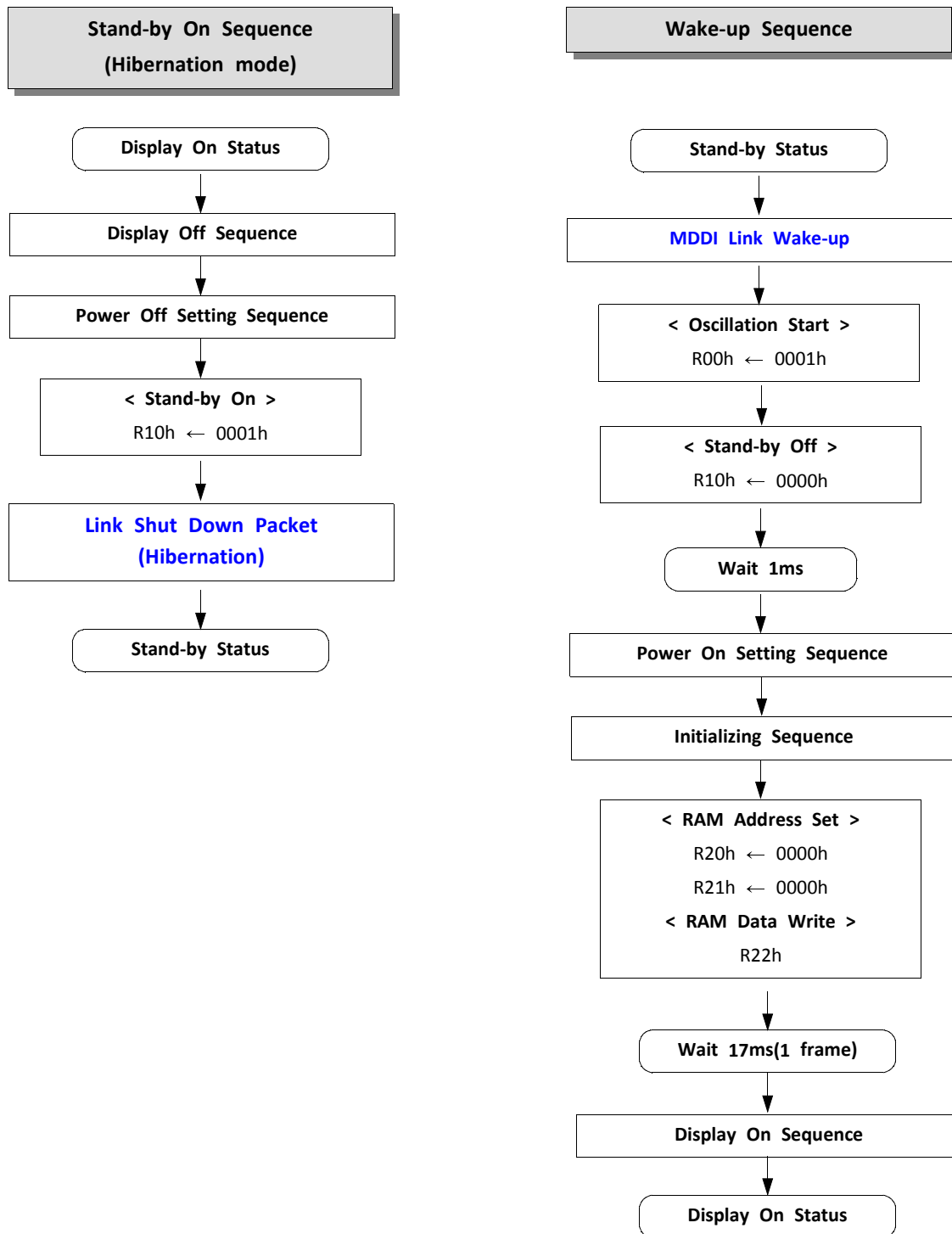

SAMSUNG MOBILE DISPLAY CO., LTD.(All Rights Reserved).

10. MDDI I/O DC/AC Characteristics

10-1 Receiver Electrical Specifications

Parameter	Description	MIN	MAX	UNIT
V_{IT+}	Differential input high threshold voltage	-	50	mV
V_{IT-}	Differential input low threshold voltage	-50		mV
V_{IT+HIB}	Receiver differential input high threshold voltage(in hibernation)	-	175	mV
V_{IT-HIB}	Receiver differential input low threshold voltage(in hibernation)	75	-	mV
$V_{input-range}$	Allowable receiver input voltage range	0	1.65	V
T_A	Jitter, bit boundary to center crossing	$0.051 * T_{BIT} + 11.5$		ps
T_B	Jitter, bit boundary to minimum output level	$0.051 * T_{BIT} + 50$		ps
T_{BIT}	Period of one forward link data bit	6.67		ns
R_{term}	Termination Resistor value	98	102	Ω

10-2 Transmitter Electrical Specifications

Parameter	Description	MIN	MAX	UNIT
$V_{output-range}$	Driver output voltage range	0.11	1.60	V
I_{OD+}	Driver differential output high current	2.5	4.5	mA
I_{OD-}	Driver differential output low current	-4.5	-2.5	mA
$T_{rise-fall}$	Rise and fall time(between 20% and 80% amplitude)of driver output	0.425	Max(100ns, $0.3 * T_{BIT.R}$)	ns
T_A	Jitter, bit boundary to center crossing	-		ps
T_B	Jitter, bit boundary to minimum output level	$0.2 * T_{BIT.R}$		ps
$T_{BIT.R}$	Period of one reverse link data bit	13.3	-	ns

※. Note : Please refer to the VESA specification Ver 1.1

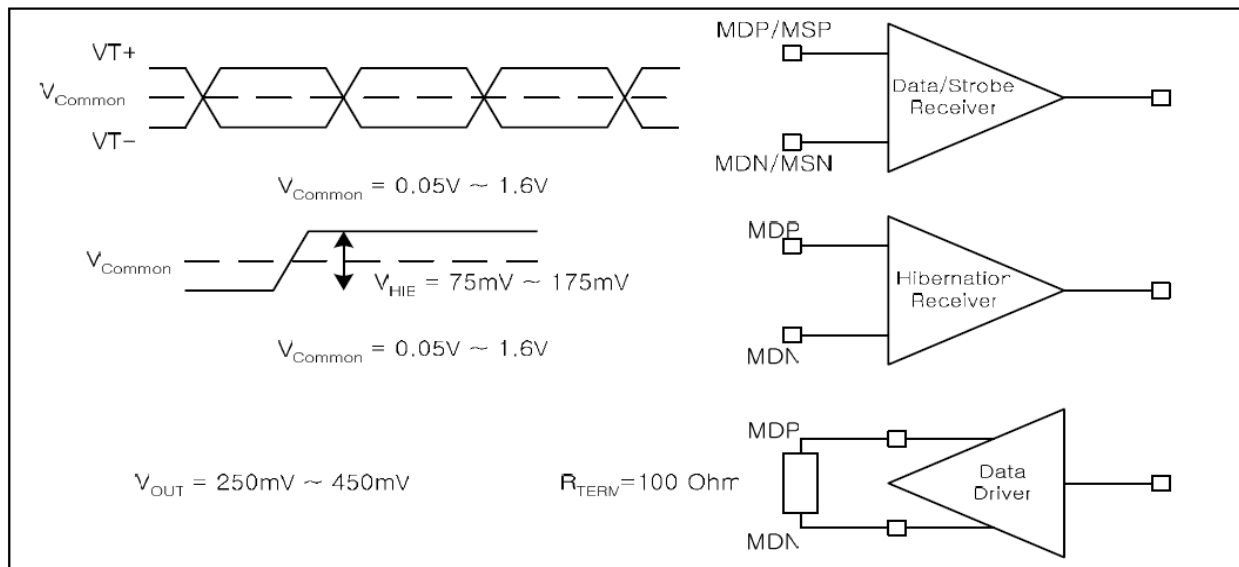

[MDDI receiver, driver electrical diagram]

10-3 Data / STB Timing

ITEM	SYMBOL	Unit	MIN	TYP	MAX
Data Transfer Rate	1/t(BIT)	Mbps	-	-	150
Differential Transfer Input Skew	$ \pm t(\text{skew-pair-i}) $	ns	-	-	0.250
Data_Stb Input Skew	$ \pm t(\text{diff-skew-i}) $	ns	-	-	2.860 (from 0.439* (tBIT-150ps))

Skew between Positive and Negative

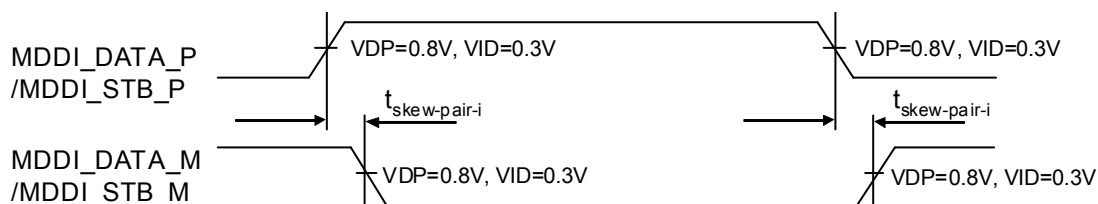

Skew between DATA_P/M and STB_P/MNegative

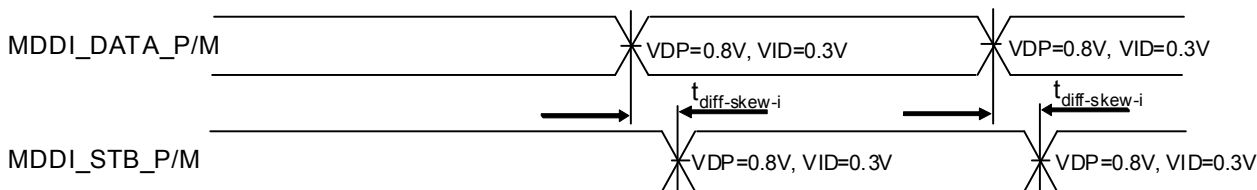

10-4 Reset Input Timing

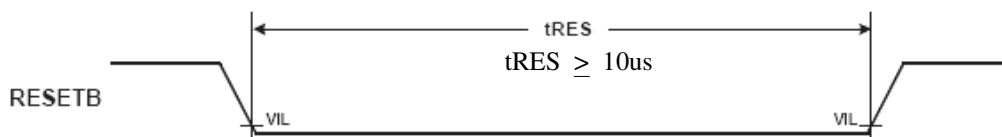

(VDD3=2.6V, VCI=2.8V, Ta=-20~+60°C)

ITEM	SYMBOL	CONDITION	MIN	MAX	UNIT	PORT
Reset time	t_{RES}		10	-	us	

11. Quality Level

11-1. Environment Condition

The environmental conditions for inspection shall be as follows.

① Temperature & Humidity

Room temperature : $22 \pm 3^{\circ}\text{C}$

Humidity : $65 \pm 20\%RH$

② Viewing distance : 30cm

Viewing angle(tolerance) : $\pm 30^{\circ}$

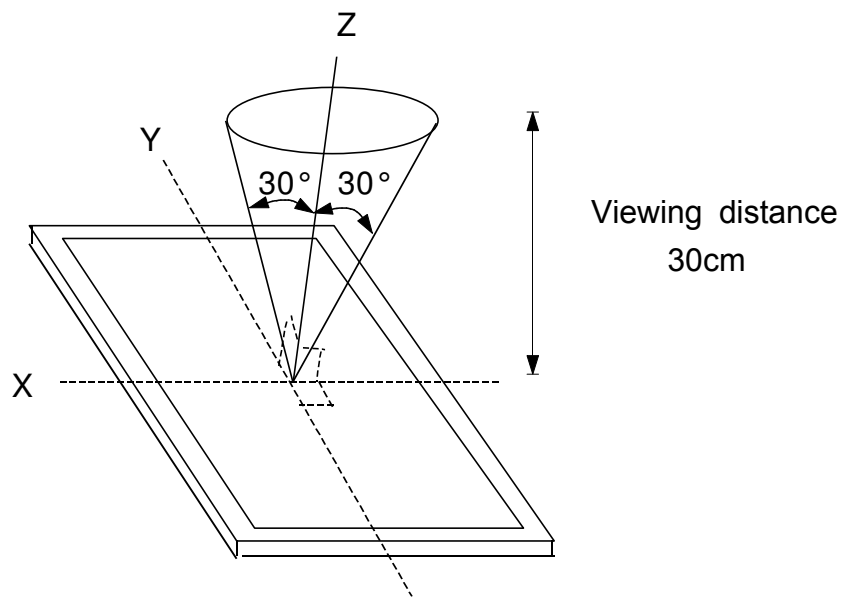

SAMSUNG MOBILE DISPLAY CO., LTD.(All Rights Reserved).

11-2. Sampling Procedures for each item's acceptance table

Defect type	Sampling Procedures	AQL
Major Defect	MIL-STD-105D Inspection level normal inspection single sample inspection	0.65
Minor Defect	MIL-STD-105D Inspection level normal inspection single sample inspection	1.5

① Major defect

: A major defect refers to a defect which may substantially degrade usability for product applications.

② Minor defect

: A minor defects refers to a defect which is not considered to substantially degrade product application, or a defect which deviates from existing standards almost unrelated to the effective use of the product or its operation.

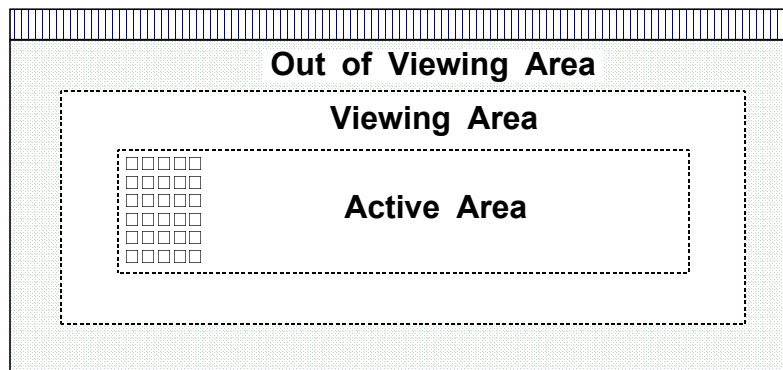
③ Defect application zone : Active Area + Viewing Area

- Defect in "Out of View Area" Zone should not be judged.

11-3. Inspection Item(cosmetics)

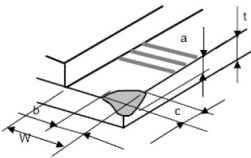
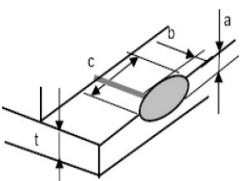
No.	Item	Criteria	Defect Type								
1	Non Display	Not allowed.	Major								
2	Abnormal Display	Not allowed.	Major								
3	Line Defect	Not allowed. (Vertical line/ Horizontal line / Periodical line)	Major								
4	Dark Spot or Bright Spot	<table border="1" style="margin-left: auto; margin-right: auto;"> <thead> <tr> <th colspan="2">Acceptable number</th> </tr> <tr> <th>Dark Spot</th> <th>Bright Spot</th> </tr> </thead> <tbody> <tr> <td style="text-align: center;">1</td> <td style="text-align: center;">0</td> </tr> </tbody> </table> <p>※ Dark spot means that a sub-pixel is completely dead.</p>	Acceptable number		Dark Spot	Bright Spot	1	0	Minor		
Acceptable number											
Dark Spot	Bright Spot										
1	0										
5	Dent, Contamination, Pit, Bubble	<table border="1" style="margin-left: auto; margin-right: auto;"> <thead> <tr> <th>Area A (mm²)</th> <th>Acceptable number</th> </tr> </thead> <tbody> <tr> <td style="text-align: center;">$A \leq 0.03$</td> <td style="text-align: center;">1</td> </tr> <tr> <td style="text-align: center;">$0.03 < A$</td> <td style="text-align: center;">0</td> </tr> </tbody> </table> <p>※ This items should be judged under the display on.</p>	Area A (mm ²)	Acceptable number	$A \leq 0.03$	1	$0.03 < A$	0	Minor		
Area A (mm ²)	Acceptable number										
$A \leq 0.03$	1										
$0.03 < A$	0										
6	Scratch on Polarizer	No visible scratches allowed. ※ This items should be judged under the display on.	Minor								
7	Surface Stain	A stain on the display surface which can affect display status and cannot be cleaned by using soft cloth and wiping gently is not permitted.	Minor								
8	Glass Crack	Not allowed.	Major								
9	Newton's Ring	Not allowed.	Minor								
10	Crosstalk	Not allowed.	Minor								
11	Glass Chip on corner	 <table border="1" style="margin-left: auto; margin-right: auto;"> <thead> <tr> <th>Item</th> <th>Acceptable Size</th> </tr> </thead> <tbody> <tr> <td style="text-align: center;">a</td> <td style="text-align: center;">$a < t$</td> </tr> <tr> <td style="text-align: center;">b</td> <td style="text-align: center;">$b < 2.0\text{mm}$</td> </tr> <tr> <td style="text-align: center;">c</td> <td style="text-align: center;">$c < 2.0\text{mm}$</td> </tr> </tbody> </table> <p>※Any damage is not allowed to the Seal or Pattern area.</p>	Item	Acceptable Size	a	$a < t$	b	$b < 2.0\text{mm}$	c	$c < 2.0\text{mm}$	Minor
Item	Acceptable Size										
a	$a < t$										
b	$b < 2.0\text{mm}$										
c	$c < 2.0\text{mm}$										
12	Glass Chip on side	 <table border="1" style="margin-left: auto; margin-right: auto;"> <thead> <tr> <th>Item</th> <th>Allowable Size</th> </tr> </thead> <tbody> <tr> <td style="text-align: center;">a</td> <td style="text-align: center;">$a < t$</td> </tr> <tr> <td style="text-align: center;">b</td> <td style="text-align: center;">$b < 0.5\text{mm}$</td> </tr> <tr> <td style="text-align: center;">c</td> <td style="text-align: center;">$c < 5.0\text{mm}$</td> </tr> </tbody> </table> <p>※Any damage is not allowed to the Seal or Pattern area.</p>	Item	Allowable Size	a	$a < t$	b	$b < 0.5\text{mm}$	c	$c < 5.0\text{mm}$	Minor
Item	Allowable Size										
a	$a < t$										
b	$b < 0.5\text{mm}$										
c	$c < 5.0\text{mm}$										

SAMSUNG MOBILE DISPLAY CO., LTD.(All Rights Reserved).

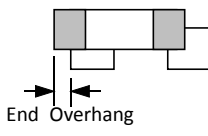
No	Item	Criteria	Defect Type
13	SMT (Soldering) on FPCB	(1) No polarity opposition (2) No wrong insertion	Minor
14	End of overhang of FPCB	Please refer to IPC-CM-770 specs.  End Overhang	Minor
15	Soldering defects	Visible cracks in soldering area not allowed.	Minor
16	Solder Ball	Movable solder ball which can cause electrical short is not allowed.	Minor

※ Visual Inspection Condition ; 300cd/m² , 150 ± 50 lux

※ Display pattern : White, Gray, Black, Red, Green, Blue

SAMSUNG MOBILE DISPLAY CO., LTD.(All Rights Reserved).

12. Reliability

12-1 Items of reliability

: All test result of items should be judged in 2 hours recovery time at room temperature.

[Note] Brightness condition : 300cd/m²

No	Item	Condition	Sample	Criteria
1	High Temp. Storage	240hrs @+70°C, 10%RH	6pcs	* No cosmetic defects are permitted
2	Low Temp. Storage	240hrs @-40°C	6pcs	
3	Thermal Shock Storage	5cycle(2H) @-40°C ↔ 85°C	6pcs	* Current consumption should be less than the Max. of Ibat.
4	High Temp. Operating	240hrs @+65°C	6pcs	
5	High Temp./Humid Operating	240hrs @+65°C*96%RH	12pcs	* Brightness difference must be less than 20% of initial value. (But, brightness difference of #1 may be accepted by 40%)
6	Low Temp. Operating	240hrs @-20°C	6pcs	
7	ESD Test @Non-Operating	- . Contact: +/-6kV - . Air: +/-10kV	6pcs	* No cosmetic and electrical defects are permitted. (Note 1) * Current consumption should be less than the Max. of Ibat.
8	Sine Vibration @Non-Operating	Frequency: 10~500~10Hz, Amplitude/Acceleration: 1G Sweep rate: 0.25bd/cotave Duration: 1 cycle, Complete test on 3 orientations	6pcs	* No cosmetic defects are permitted
9	Random-vibration @Non-Operating	10~80Hz +3dB/octave 80~300Hz 0.045 g ² /Hz 300~1500Hz -3dB/octave Duration: 45mins/ axis	6pcs	* Current consumption should be less than the Max. of Ibat.
10	Altitude, Non-Operating	40,000ft, 60°C 48Hr	6pcs	
11	Impact Test	Steel ball, Load: 21.68g, Height: 50cm, total 10 times	6pcs	* No cosmetic and electrical defects are permitted.
12	Dust Test	1. Place 2 tablespoons of baby powder in a large zip lock bag. 2. Rotate bag clockwise for 15 seconds. & counter-clockwise for 15 seconds(Total 60 seconds).	6pcs	* Any dust seen inside the panel is considered a failure.
13	Crunch Test	1. Mark 9 test spots on Display surface 2. 3kg load at point1, Φ10mm. 3. Retain 10sec, release the load and change to test point2. 4. Repeat step 2 & 3 on point2 until all test point is conducted.	6pcs	* No cosmetic defects are permitted (Note 2)

Note 1) A sample malfunction caused by ESD damage but operating as normal goods will not be considered a failure.

SAMSUNG MOBILE DISPLAY CO., LTD.(All Rights Reserved).

defective product.

Note 2) Crunch Test

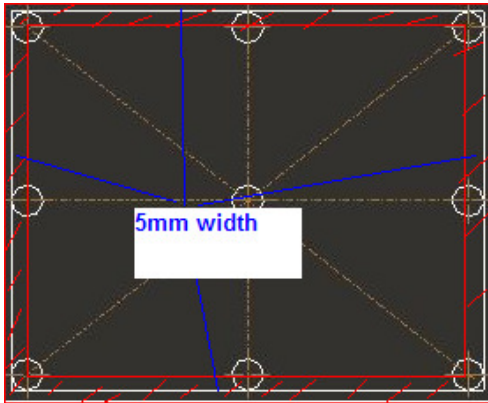

[Top view]

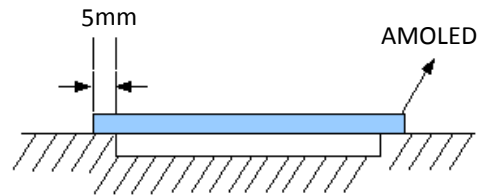

[Cross-section view]

SAMSUNG MOBILE DISPLAY CO., LTD.(All Rights Reserved).

13. Handling Precautions

13-1. Mounting Method

The display panel consists of a thin glass substrate with polarizers and encapsulation glass, which may easily get damaged. Therefore the display module should be protected from external damage; for example drop, high pressure onto glass etc..

13-2. Caution of AMOLED Handling and Cleaning

When a user needs to clean the display surface, then must use a soft cloth must be used or it should be wiped with the following solvents.

* Recommended Volatile Solvent:

- ⊙ Isopropyl alcohol
- ⊙ Ethyl alcohol
- ⊙ Trichlorotrifluoroethane

It is prohibited to wipe the display surface with dry or hard materials that will damage the polarizer surface. Do not use the following solvents:

* Prohibited Solvent:

- ⊙ Water
- ⊙ Ketone
- ⊙ Aromatics

Do not wipe the ITO pad area with dry or hard materials since it may cause damage to the ITO patterns. Do not use the following solvents on the pad to prevent it from being contaminated:

* Prohibited Materials on ITO Pattern:

- ⊙ HCFC (Other area except ITO pad can use the HCFC for cleaning process)
- ⊙ Soldering flux
- ⊙ Chlorine(Cl), Sulfur(S)
- ⊙ Spittle, Fingerprint

13-3. Static Charge

The display module uses C-MOS LSI drivers and a LTPS glass substrate, therefore SMD strongly recommends that users should protect the display module from ESD damages.

- * Connect all input signals to phone set. If there are unused input terminals, then those should be connected to VCI/VDD3 or VSS.
- * Do not input any signals before the power is turned on.
- * Ground workers' body, soldering iron, specific assembly jig and machines should be connected to a ground level so that the display module will not be damaged by electrostatic discharge.
- * The ionizer should be settled to prevent electrostatic discharge when a user removes the protection film on the polarizer.

SAMSUNG MOBILE DISPLAY CO., LTD.(All Rights Reserved).

13-4. Safekeeping

SMD recommends that a user should keep the display modules as packed. If a user needs to unpack the modules, then the user should avoid high pressure, strong impacts or falling from shelves.

Do not leave the modules under sunshine, or expose them to high temperature or humidity to avoid quality degradation.

For safety & avoiding the module damage, Carton box must stack the below 4 boxes.

13-5. Operating precaution

- A user must run the modules within the recommended operating voltage. Higher voltage may cause electronic damage or shorten the lifetime of the display.
- Luminance differences between lit and unlit pixels may be occurred after long-term operation with a fixed pattern or image. Therefore, SMD strongly recommends that a user should not operate the display continuously with a stationary image or fixed-pattern. A user should scroll the image, so that a fixed pattern will not be displayed on the display panel for long time.
- Strong pressing onto the display area may cause defects. Therefore the gap between polarizer's surface and the window should be more than zero millimeter.
- A slight dew depositing on the terminals can cause electro-chemical reactions resulting in a terminal open circuit. Usage under the maximum operating temperature and with the maximum operating humidity or less is required
- Production Environment: The modules be handled in a dust-free environment.
- Electrostatic Discharge Damages: Be careful of the occurrence of electrostatic discharge.
- Production Environmental: Be careful when assembling the modules into a customer's phone set to prevent external forces to the modules such as twisting or excessive mechanical stress.

SAMSUNG MOBILE DISPLAY CO., LTD.(All Rights Reserved).

13-6. Storage

In the case of storing the modules for a month or more (for instance, as spare parts), the following methods are recommended.

- Keep the modules inside a sealed envelop so that outside air or humidity will not infiltrate the modules.
- Keep the modules in a shady place to avoid infrared's exposure, and maintain the storage area's temperature and humidity stable.
- Avoid touching any material onto the display surface's polarizer. SMD recommends that a user should store the modules as they are contained inside the inner carton.

⊙ Temperature & Humidity

Room temperature : $22 \pm 3^{\circ}\text{C}$, Humidity : $65 \pm 20\%RH$

⊙ Storage term : Within 6 months.

13-7. Safety Precautions

- The display panel is composed of glass may cause a skin-deep wound if a user disassembles or repairs it. Do not try to disassemble or repair the display module at discretion.
- Be careful of glass chips that may cause injury to the skin of the finger when the display part is broken.
- In the event that parts of the module is come in contact with skin, wipe the affected skin with a paper towel or gauge and wash it off well with soap and receive medical attention if necessary.
- A user's fingers may get an electrical shock when touching the module's components due to the electrostatic discharge. Please do not touch the operated display module with bare hands.
- Do not use the display module except for a specified purpose.

13-8. Employing Limit Sample

Usually limit samples can be used in SMD's production line so that an inspector may judge a products whether PASS or FAIL comparing the products to limit sample.

If the following cases shall occur then appropriate action should be taken after agreement of both parties.

- When a question arises about this specifications.
- When a new problem arises that is not specified in this specifications.
- When an inspection specification changes or operating conditions change for the customer.
- When a new problem arises at the customer's operating set

SAMSUNG MOBILE DISPLAY CO., LTD.(All Rights Reserved).

14. Drawing

14-1. Product Drawing

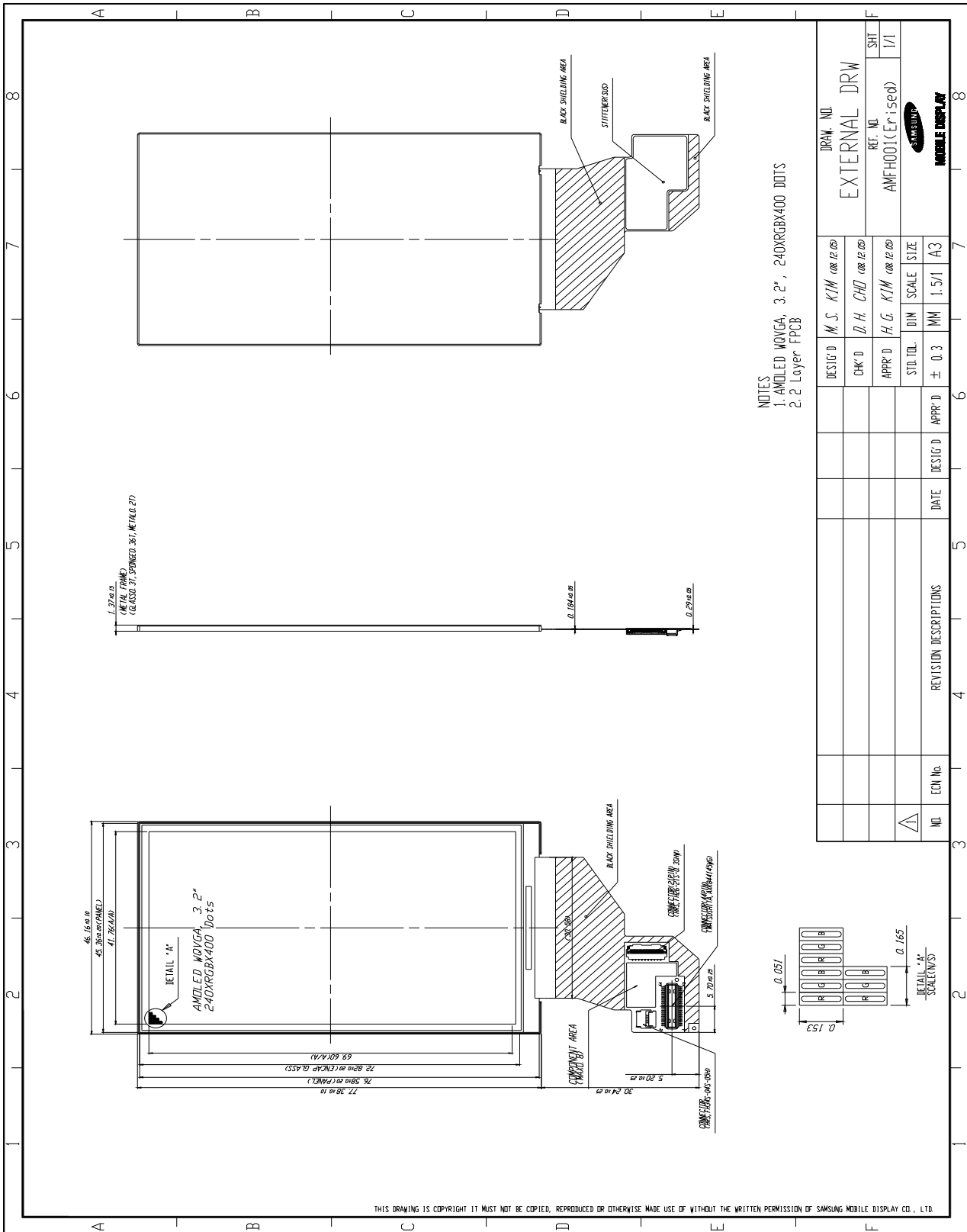

SAMSUNG MOBILE DISPLAY CO., LTD.(All Rights Reserved).

Doc. No.: AMS320FH01-0

TITLE : 3.2" 240×400, 16M AMOLED

Rev. : 0.1

30/44

14-2. FPCB Drawing

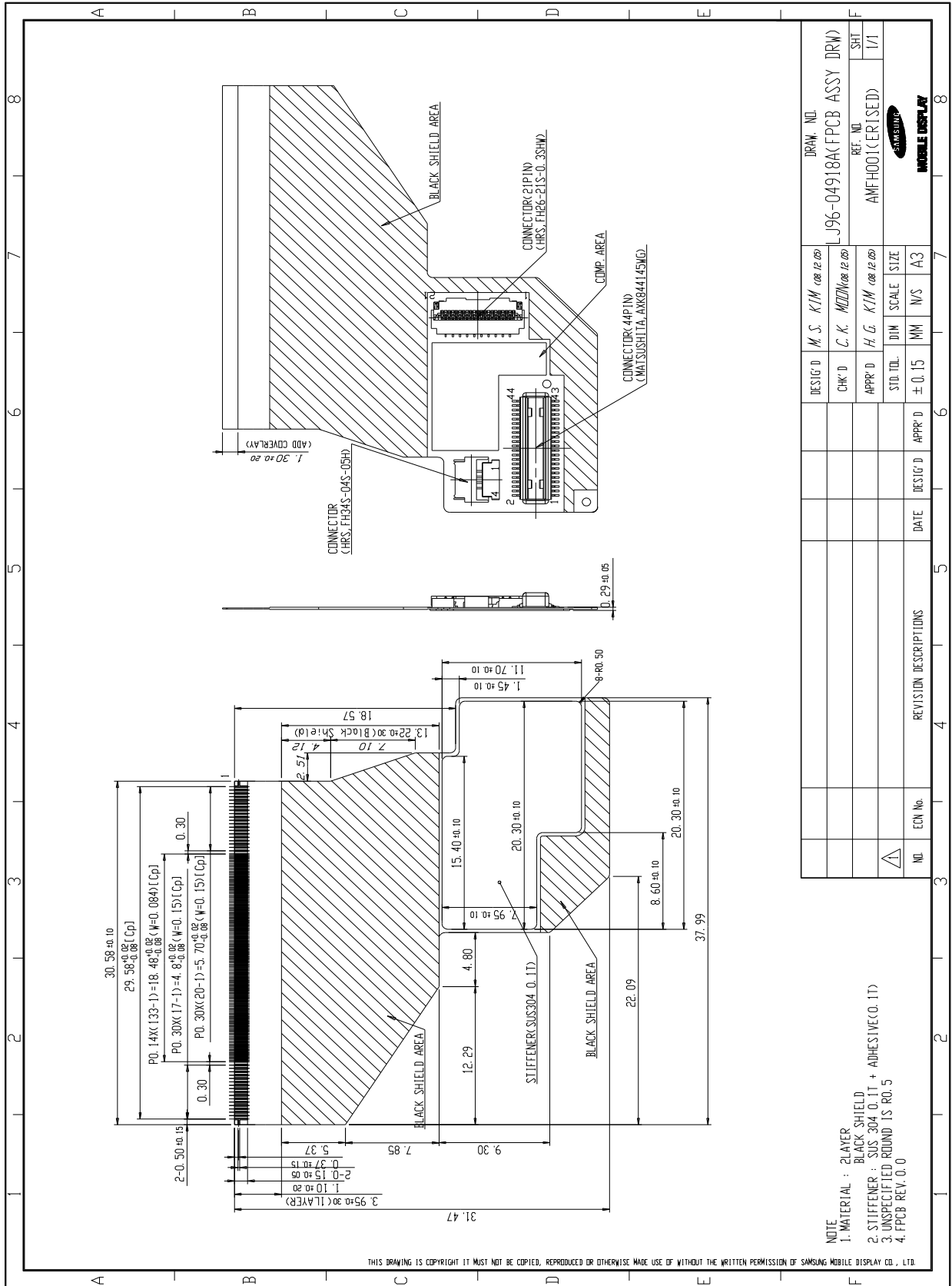

SAMSUNG MOBILE DISPLAY CO., LTD.(All Rights Reserved).

14-2-2. Electronic Part List

No.	Code	Name	Specification	Location	MAKER
1	0404-001172	DIODE-SCHOTTKY	RB520S-30,30V,200MA,SOD-523,TP	D1	ROHM
2	2203-006562	C-CER,CHIP	1000nF,10%,10V,X5R,1005, 1000nF	C25 C26 C27 C28 C29 C30 C31	KYOCERA, MURATA, SEM, TAIYO, TDK
3	2007-007306	R-CHIP	100ohm,1%,1/16W,TP,1005	R1 R2	SEM
4	2203-006399	C-CER,CHIP	1000nF,10%,6.3V,X5R,1005, 1000nF	C9	KYOCERA, MURATA, SEM, TAIYO, TDK
5	2203-006841	C-CER,CHIP	1000nF,10%,16V,X5R,1005, 1000nF	C8 C10 C11 C12 C13 C14 C15 C16	KYOCERA, SEM, TDK, AVX,
6	T.B.D	HEADER_MAIN CON	AXK844145WG, -,44,-,0.4,-,AU,-	CN1	PANASONIC
7	3708-002225	ZIF_KEYPAD	FH26-21S-0.3SHW, 21P,0.3mm,SMD-A,AU,Y,FLIP,BOTTOM	CN2	HIROSE
8	T.B.D	ZIF_TSP	FH34S4S0.5SH, 4,0.5,-,AU,-,-,-	CN3	HIROSE

SAMSUNG MOBILE DISPLAY CO., LTD.(All Rights Reserved).

Doc. No.: AMS320FH01-0

TITLE : 3.2" 240×400, 16M AMOLED

Rev. : 0.1

33/44

14-2-3. Placement (Rear)

PLACEMENT SPEC

DESIGNED

APROVED

C.S.SON
2008.11.28

I.H.LEE
2008.11.28

1. PLACEMENT (REAR)

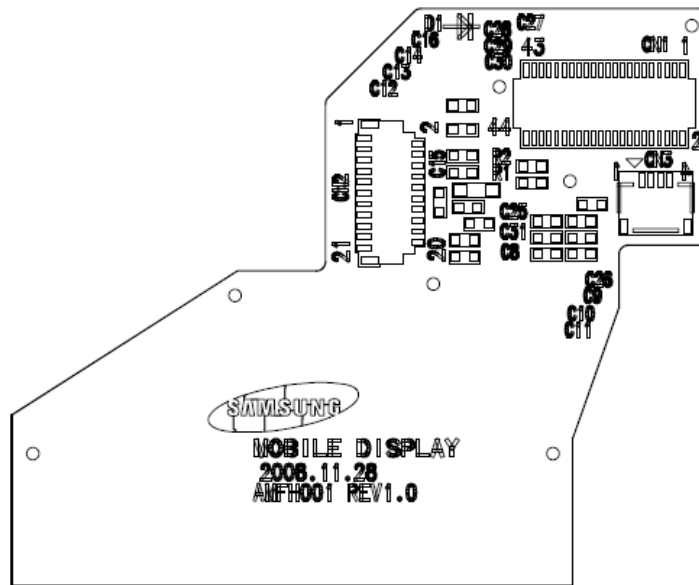

MODEL	AMFH001(REVISED)	REV 1.0
LAYER	SILICONES	
DATE	2008/11/28	DESIG.D C.S.SON
SAMSUNG MOBILE DISPLAY (All Rights Reserved)		

SAMSUNG MOBILE DISPLAY CO., LTD. (All Rights Reserved)

DOC. NO: LJ96-XXXXXA

AMFH001

REV1.0

PAGE 2/3

SAMSUNG MOBILE DISPLAY CO., LTD.(All Rights Reserved).

14-3. FPCB Structure

Model name : AMFH001	Code name :	REV: 1.0	
----------------------	-------------	----------	--

1. Main body

Layer	Material	Thickness	Maker	Part name	HALOGEN FREE	
	BLACK SHIELD	22 μm	TATSUTA	SF-PC5000	O.K	
Double Side	C/L	film	12.5 μm	Hanhwa	HGCS-A505L	O.K
		Adhesive	25 μm			
	Cu plating		10 μm			O.K
	FCCL	Copper	12 μm	Doosan	DSFLEX-600 122012E	O.K
		Adhesive	0 μm			
		Base film	20 μm			
		Adhesive	0 μm			
		Copper	12 μm			
	Cu plating		10 μm			
	C/L	Adhesive	25 μm	Hanhwa	HGCS-A505L	O.K
film		12.5 μm				
	BLACK SHIELD	22 μm	TATSUTA	SF-PC5000	O.K	
Total Thickness		183 μm				

-Theoretical thickness can be different from product thickness

2. Bonding part(FOG) & Bending part

Layer	Material	Thickness	Maker	Part name	HALOGEN FREE	
Double Side	C/L	film		Hanhwa	HGCS-A505L	O.K
		Adhesive	μm			
	Cu plating		10 μm			
	FCCL	Copper	12 μm	Doosan	DSFLEX-600 122012E	O.K
		Adhesive	0 μm			
		Base film	20 μm			
		Adhesive	0 μm			
		Copper	μm			
	Cu plating		μm			
	C/L	Adhesive	25 μm	Hanhwa	HGCS-A505L	O.K
film		12.5 μm				
Total Thickness		79.5 μm				

-Theoretical thickness can be different from product thickness

3.Connector part

Layer	Material	Thickness	Maker	Part name	HALOGEN FREE	
	STIFFENER	100 μm	Bashille	0.1T SUS	O.K	
	TAPE	30 μm	TESA	TESA 51983	O.K	
Double Side	C/L	film	12.5 μm	Hanhwa	HGCS-A505L	O.K
		Adhesive	25 μm			
	Cu plating		10 μm			
	FCCL	Copper	12 μm	Doosan	DSFLEX-600 122012E	O.K
		Adhesive	0 μm			
		Base film	20 μm			
		Adhesive	0 μm			
		Copper	12 μm			
	Cu plating		10 μm			
	C/L	Adhesive	25 μm	Hanhwa	HGCS-A505L	O.K
film		12.5 μm				
	BLACK SHIELD	22 μm	TATSUTA	SF-PC5000	O.K	
Total Thickness		291 μm				

-Theoretical thickness can be different from product thickness

SAMSUNG MOBILE DISPLAY CO., LTD.(All Rights Reserved).

14-4. FPCB Layer Pattern

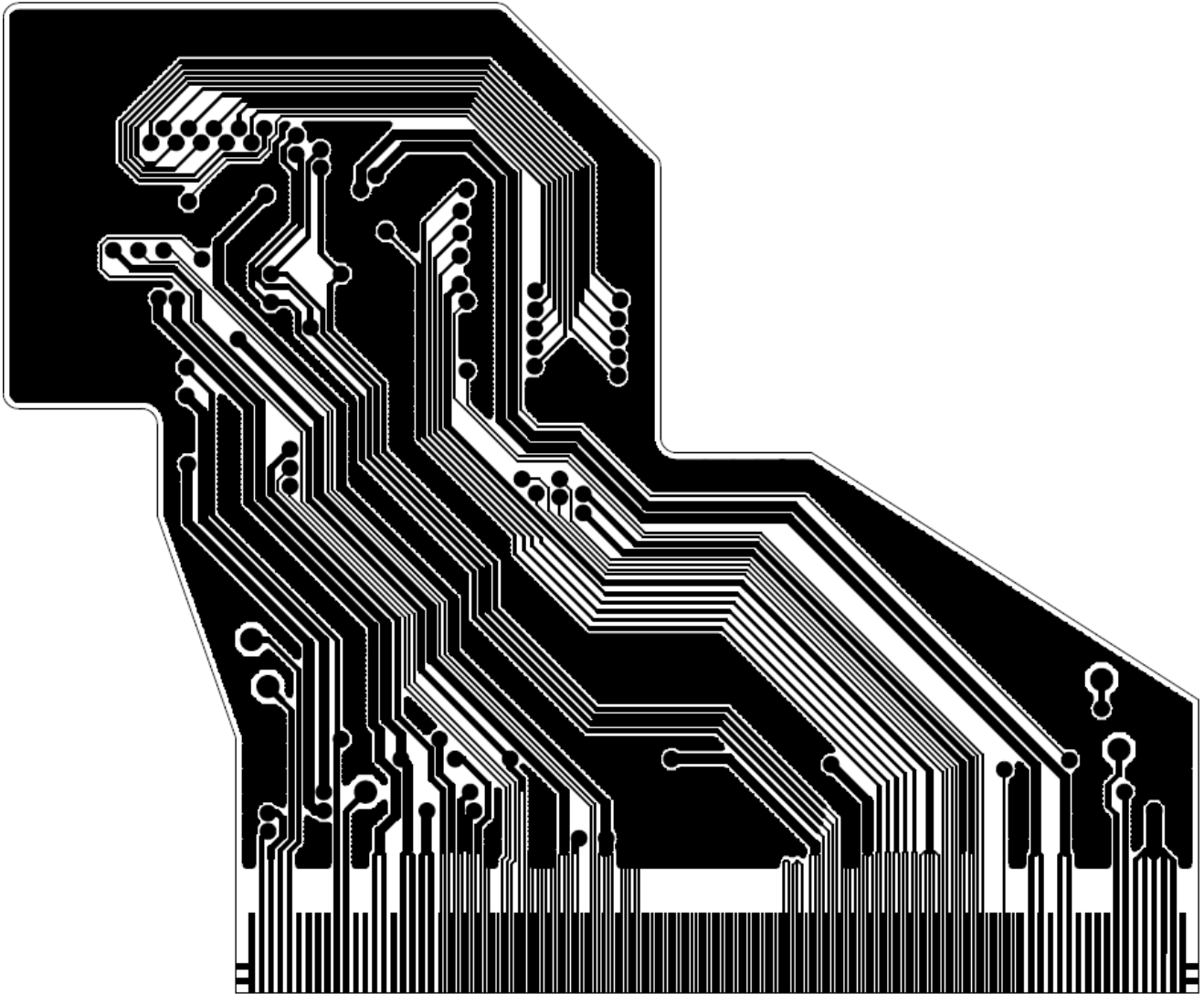

MODEL	AMFH001(ERISED)	REV	1.0
LAYER	SIGNAL_1	(LAY1/2)	
DATE	2008/11/28	DESIG'D	C.S.SON
SAMSUNG MOBILE DISPLAY(All Rights Reserved)			

SAMSUNG MOBILE DISPLAY CO., LTD.(All Rights Reserved).

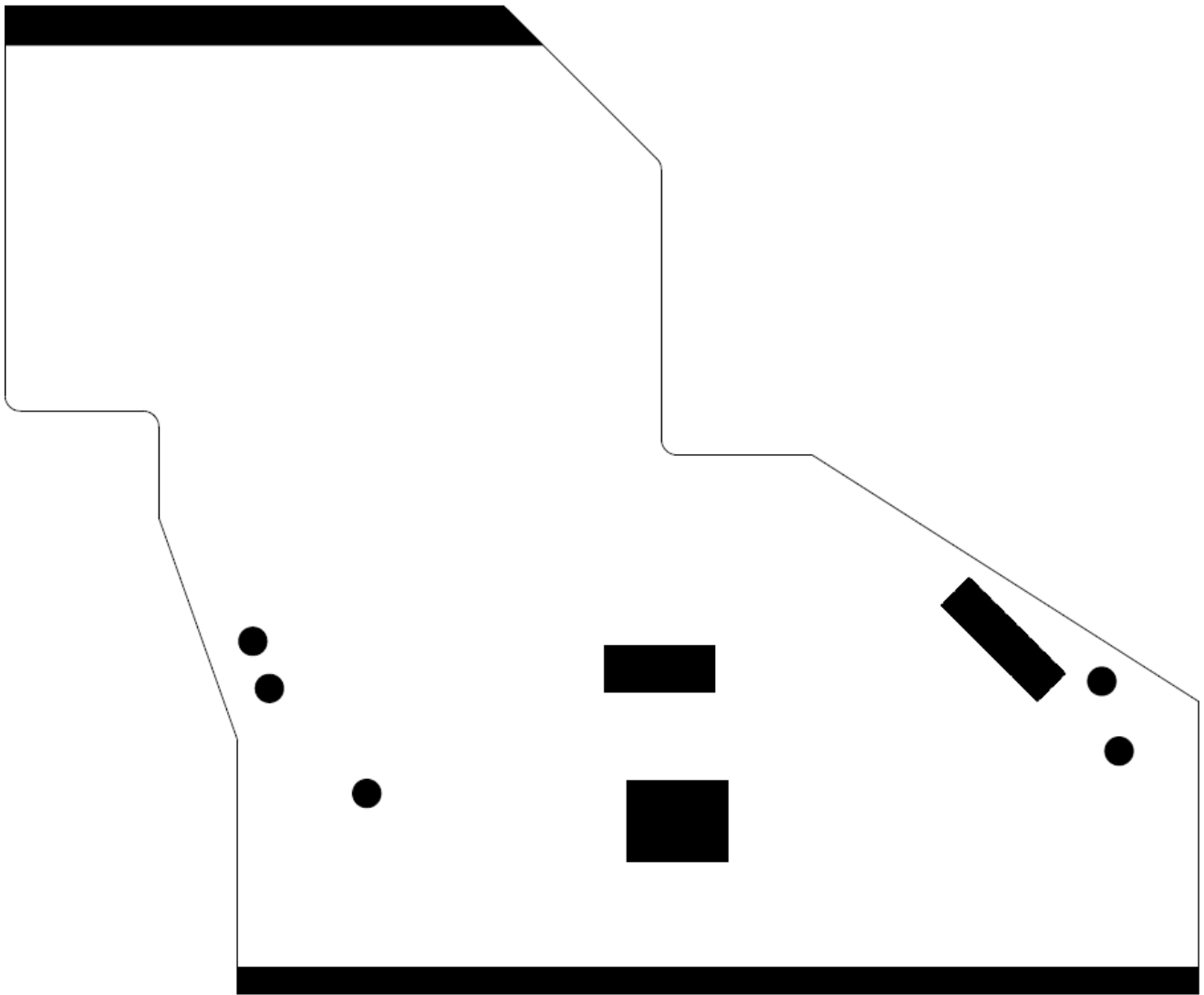

MODEL	AMFH001(ERISED)	REV	1.0
LAYER	SOLDER_MASK_1		
DATE	2008/11/28	DESIG'D	C.S.SON
SAMSUNG MOBILE DISPLAY(All Rights Reserved)			

SAMSUNG MOBILE DISPLAY CO., LTD.(All Rights Reserved).

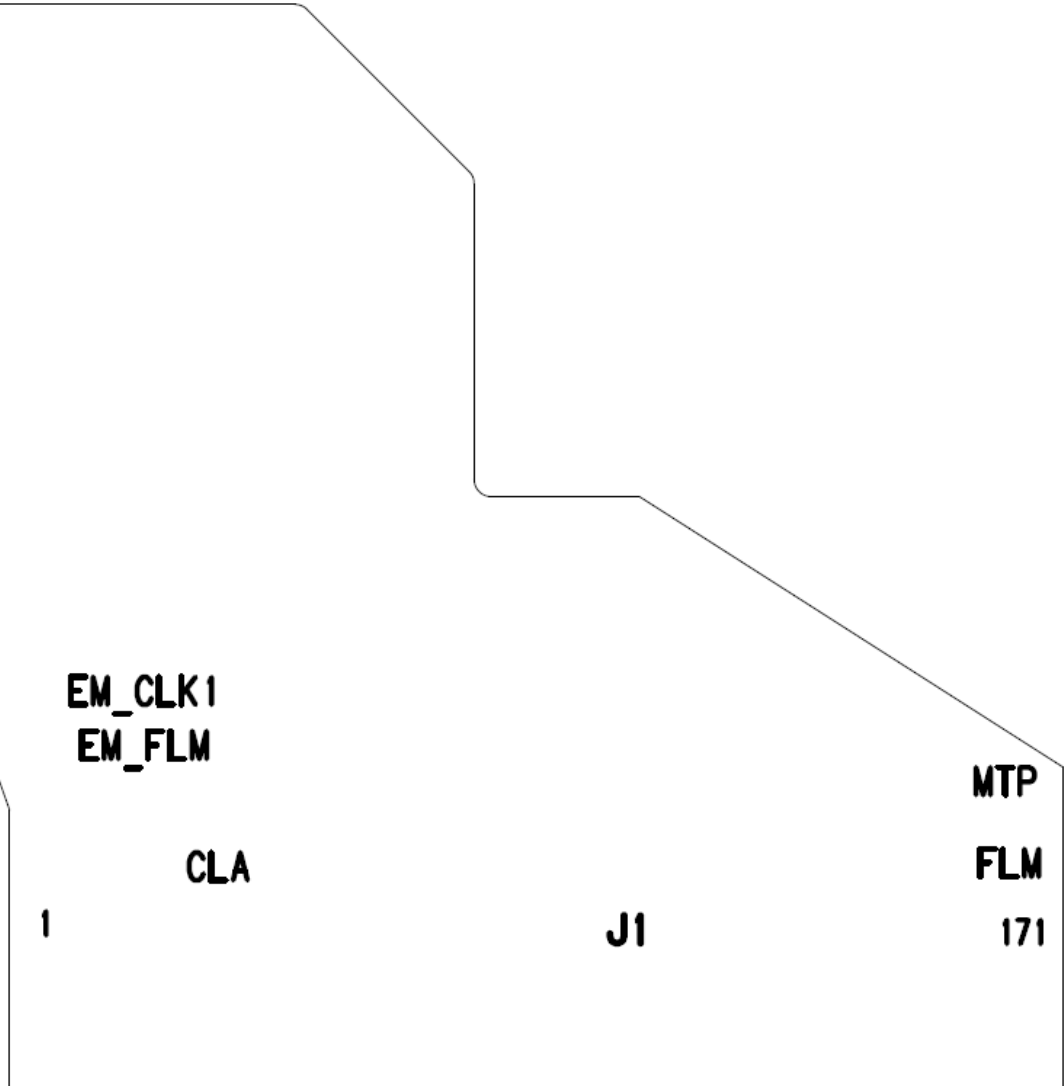

MODEL	AMFH001(ERISED)	REV	1.0
LAYER	SILKSCREEN_1		
DATE	2008/11/28	DESIG'D	C.S.SON
SAMSUNG MOBILE DISPLAY(All Rights Reserved)			

SAMSUNG MOBILE DISPLAY CO., LTD.(All Rights Reserved).

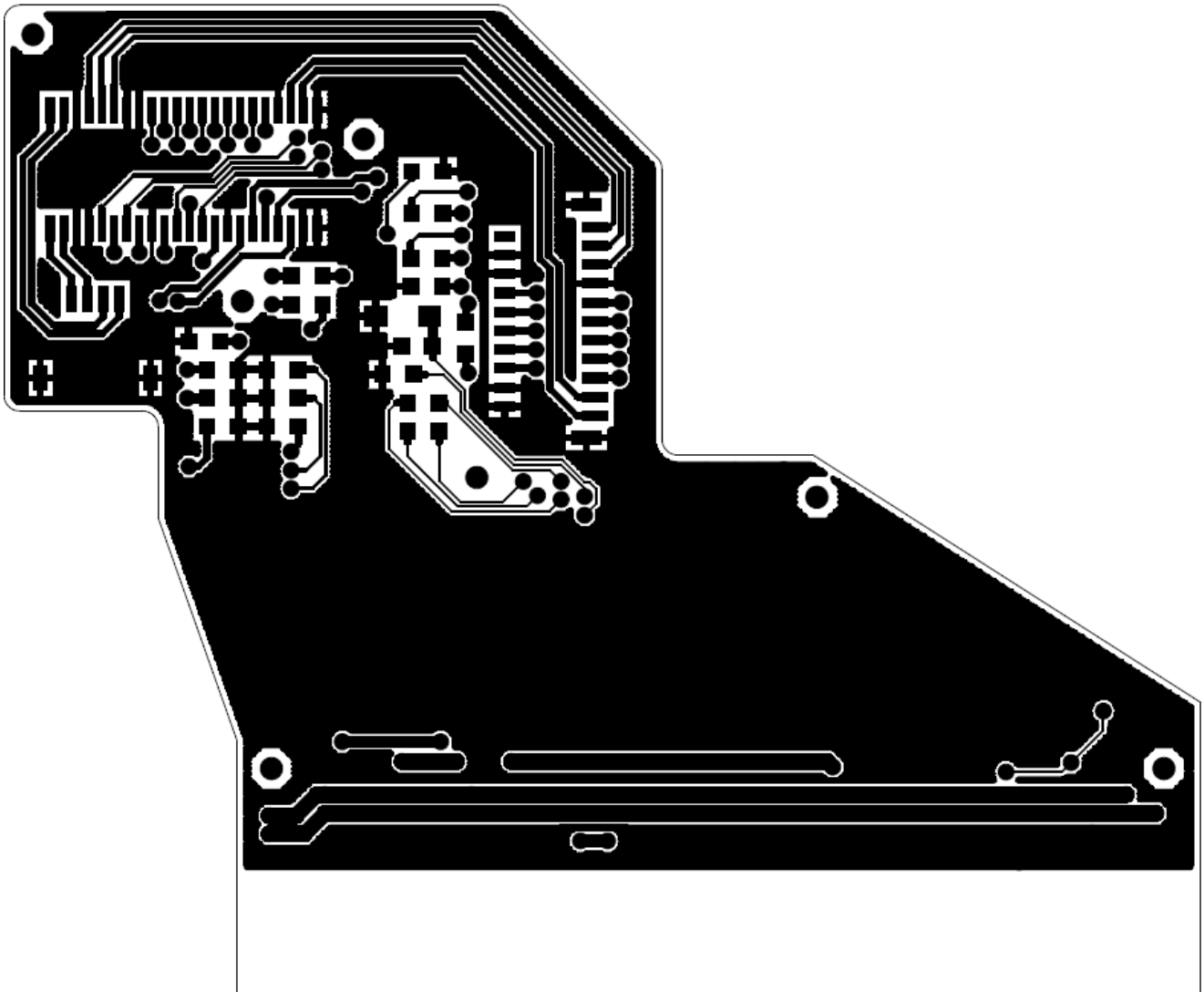

MODEL	AMFH001(ERISED)	REV	1.0
LAYER	SIGNAL_2	(LAY2/2)	
DATE	2008/11/28	DESIG'D	C.S.SON
SAMSUNG MOBILE DISPLAY(All Rights Reserved)			

SAMSUNG MOBILE DISPLAY CO., LTD.(All Rights Reserved).

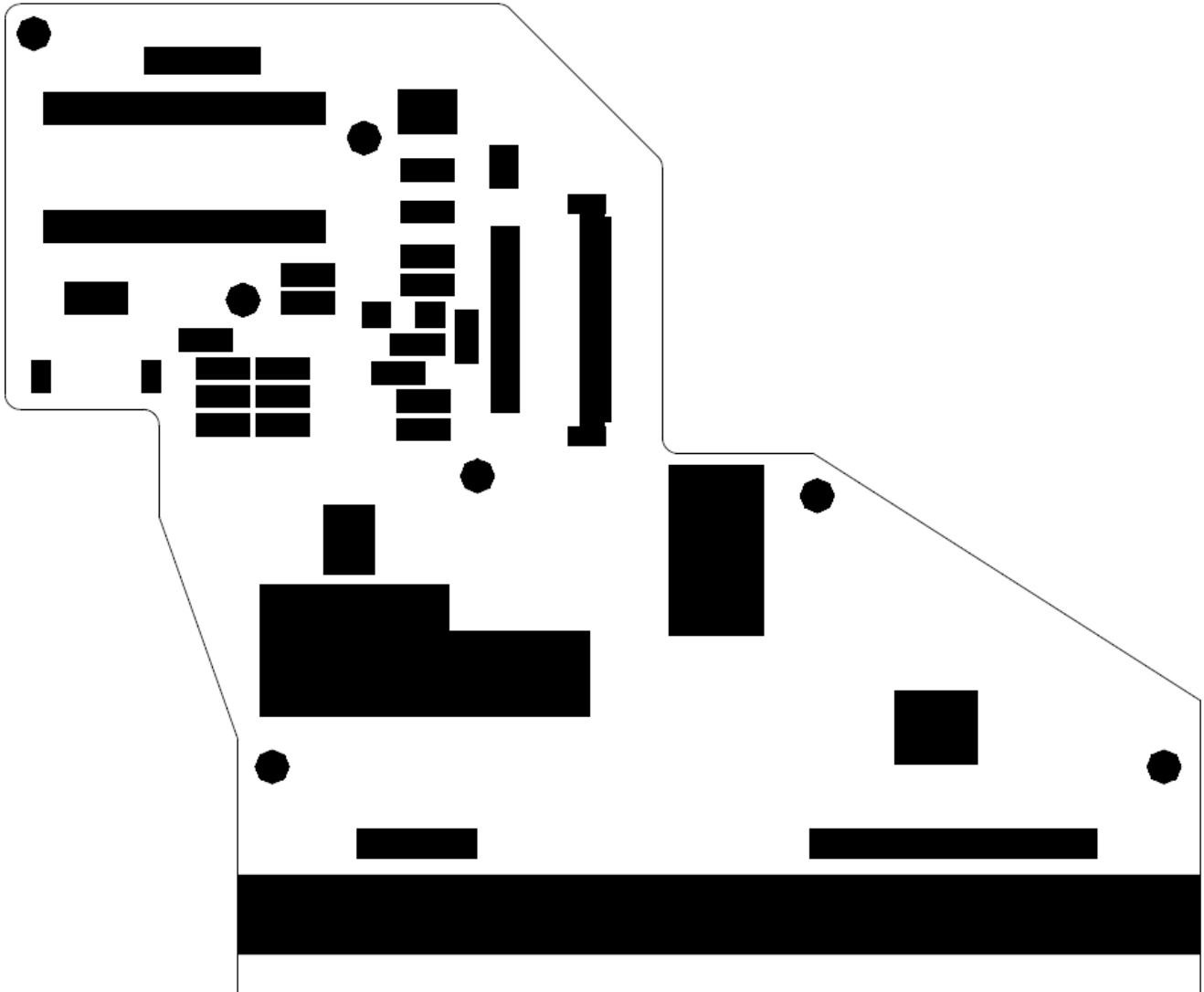

MODEL	AMFH001(ERISED)	REV	1.0
LAYER	SOLDER_MASK_2		
DATE	2008/11/28	DESIG'D	C.S.SON
SAMSUNG MOBILE DISPLAY(All Rights Reserved)			

SAMSUNG MOBILE DISPLAY CO., LTD.(All Rights Reserved).

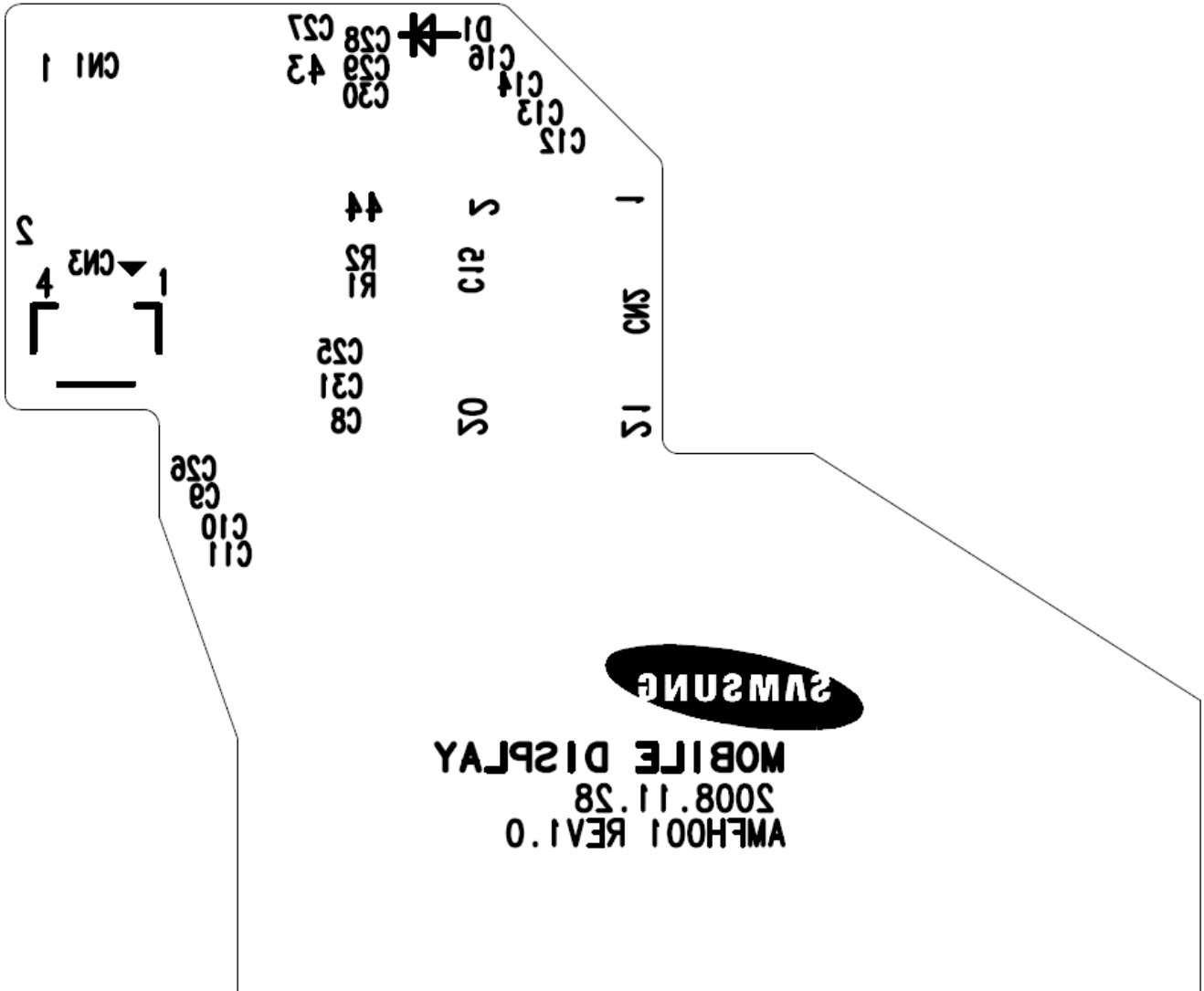

MODEL	AMFH001(ERISED)	REV	1.0
LAYER	SILKSCREEN_2		
DATE	2008/11/28	DESIG'D	C.S.SON
SAMSUNG MOBILE DISPLAY(All Rights Reserved)			

SAMSUNG MOBILE DISPLAY CO., LTD.(All Rights Reserved).

14-5. Packing Drawing

T.B.D

SAMSUNG MOBILE DISPLAY CO., LTD.(All Rights Reserved).

Doc. No.: AMS320FH01-0

TITLE : 3.2" 240×400, 16M AMOLED

Rev. : 0.1

42/44

14-5-1. Module Marking Rule

T.B.D

14-5-2. Inner Box Label

T.B.D

SAMSUNG MOBILE DISPLAY CO., LTD.(All Rights Reserved).

14-5-3. Carton Box Label

T.B.D

SAMSUNG MOBILE DISPLAY CO., LTD.(All Rights Reserved).

Doc. No.: AMS320FH01-0

TITLE : 3.2" 240×400, 16M AMOLED

Rev. : 0.1

44/44