

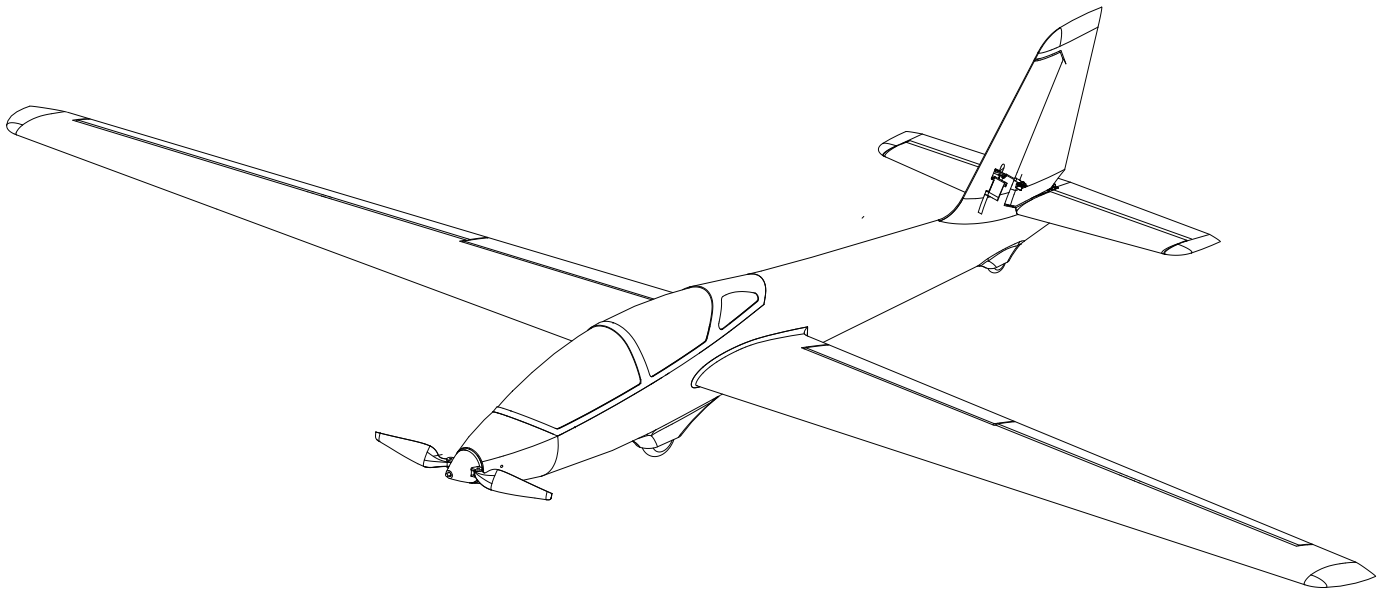

# 2300MM FOX



MAN-G0057

Instruction Manual  
操作手册

**SIMPLE**  
• SIMPLE ASSEMBLY

**ROBUST**  
• STRONG DURABLE EPO

**STABLE**  
• SMOOTH FLYING PERFORMANCE

**FMSHOBBY.COM**

**WARNING**

**WARNING:** Read the ENTIRE instruction manual to become familiar with the features of the product before operating. Failure to operate the product correctly can result in damage to the product, personal property and cause serious injury.

This is a sophisticated hobby product and NOT a toy. It must be operated with caution and common sense and failure to do so could result in injury or damage to the product or other property. This product is not intended for use by children without direct adult supervision.

This manual contains instructions for safety operation and maintenance. It is essential to read and follow all the instructions and warnings in the manual prior to assembly, setup or use, in order to operate and avoid damage or serious injury.

**Safety precautions and warnings**

As the user of this product, you are solely responsible for operating in a manner that does not endanger yourself and others or result in damage to the product or the property of others. This model is controlled by a radio signal subject to interference from many sources outside your control. This interference can cause momentary loss of control so it is advisable to always keep a safe distance in all directions around your model, as this margin will help avoid collisions or injury.

Age Recommendation: Not for children under 14 years. This is not a toy.

- Never operate your model with low transmitter batteries.
- Always operate your model in an open area away from cars, traffic or people.
- Avoid operating your model in the street where injury or damage can occur.
- Never operate the model in populated areas for any reason.
- Carefully follow the directions and warnings for this and any optional support equipment you use (chargers, rechargeable battery packs, etc.)
- Keep all chemicals, small parts and anything electrical out of the reach of children.
- Moisture causes damage to electronics. Avoid water exposure to all equipment not specifically designed and protected for this purpose.
- Never lick or any place of any your model in your mouth as it could cause serious injury or even death.

**Safety****Lithium Polymer (Li-Po) Battery Warning**

**CAUTION:** Always follow the manufacturer's instructions for safe use and disposal of batteries. Fire, property damage, or serious injury can result from the mishandling of Li-Po batteries.

- By handling, charging or using a Li-Po Battery you assume all risks associated with lithium batteries.
    - If at any time the batteries begin to swell or balloon, discontinue use immediately!
  - Always store the batteries at room temperature in a dry area to extend the life of the battery. Always transport or temporarily store the battery in a temperature range of 40-120F. Do not store the battery or model in a car or in direct sunlight. If stored in a hot car, the battery can be damaged or even catch fire.
  - Never use a Ni-Mh Charger to charge Li-Po Batteries. Failure to charge the battery with a Li-Po compatible charger may cause fire resulting in personal injury and property damage.
  - Never discharge Li-Po Cells below 3V.
  - Never leave charging batteries unattended.
  - Never charge damaged batteries.
- Charging the Flight Battery Warning**
- Use a battery charger that is designed to safely charge the Li-Po Battery. Read the charger instructions carefully before use. When charging the battery, make certain the battery is on a heat resistant surface. It is also highly recommended to place the Li-Po Battery inside a fire resistant charging bag readily available at hobby shops or online.

## Introduction

The MDM 1 Fox is a composite unlimited aerobatic glider. So impressive that at its first public unveiling it managed to place first in the World Championships! Since then it has become a podium regular throughout the world. Sleek and efficient with fantastic unlimited aerobatic flight, it is an excellent model for FMS to replicate.

This exciting aerobatic glider from FMS is made with impact-absorbing and resilient EPO foam. The mold quality is sublime, contributing to both the efficiency and great looks of the plane. Combined with a high-powered brushless motor and LiPo battery, the FMS 2300mm Fox, gives the budding modeler a new level of high performance excitement.

The FMS Fox features built-in reinforcing rods and plates in its wings, a horizontal stabilizer and vertical stabilizer that are a great support for overall strength and a very compact airframe, adding further to the enjoyment of this model.

Fox V2 has been upgraded with new features such as flaps and ball links, which enable the Fox to be a full house glider capable of camber, crow, and reflex. Other new features include a redesigned motor mount, revised horizontal stabilizer, improved wings and a refined fuselage, enabling the FOX to perform various gliding movements with increased confidence.

Positive and negative loops, stall turns, point rolls and inverted flight are all easily performed with this model and it will also perform excellently simply hunting for thermals or slope flying, making it suitable for a wide range of pilots.

### Features:

- Power configuration: Motor 4018-KV900, 30A ESC (with brake function), 9g servo x 6pcs;
  - Built-in reinforcement rods and plates in mainwing, horizontal stabilizer and vertical stabilizer for improved aircraft strength;
  - Ball link connectors are used replacing the traditional clevis;
  - Huge 2300mm wingspan provides stable flights and long fly times. A perfect platform for aerial photography;
  - Removable wings for easy transportation;
- EPO foam construction.

## Table of contents

Introduction .....	3
Kit contents .....	3
Model assembly .....	4
Battery installation .....	7
Receiver diagram .....	7
Get your model ready to fly .....	7
Clevis installation .....	8
Control horn and servo arm settings .....	9
Center of gravity(CG) .....	9
Before flying the model .....	9
Flying course .....	10
Troubleshooting .....	11
Spare parts list content .....	11
Brushless ESC introduction .....	12

## Kit contents

Before assembly, please inspect the contents of the kit. The diagram opposite details the contents of the kit with labels. If any parts are missing or defective, please identify the name or part number (refer to the spare parts list near the end of the manual) then contact your local shop or email us: support@fmsmodel.com

### Specifications

Wing span:2300mm /91.4in
Overall length: 1290mm /50.8in
Flying weight: ~ 1150g
Motor size: 4018-kv1900
Wing load:30.7g/dm <sup>2</sup>
Wing area: 37.5dm <sup>2</sup>
ESC:30A
Servo: 9g Servo x 6
Recommended battery: Li-Po 11.1V 1300mAh 25C

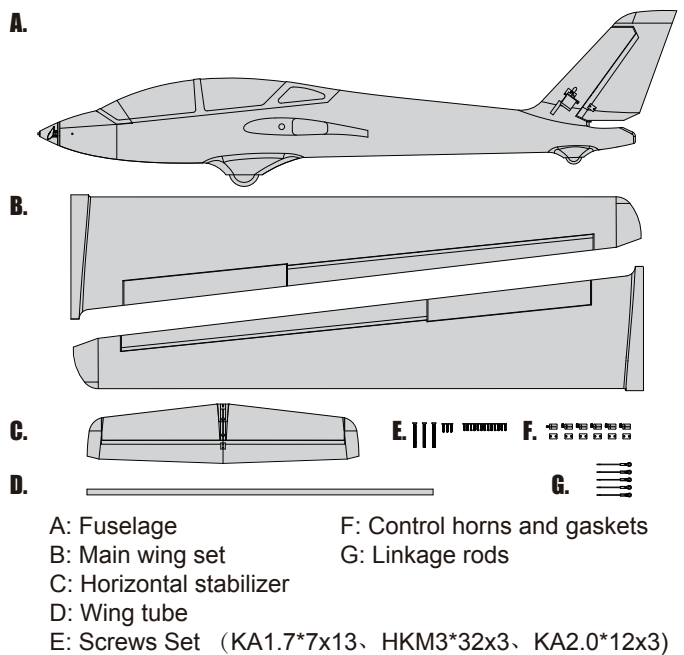

## Model assembly

### Flap and aileron Linkage rod installation

1. Open the accessory bag and take out the control horn and gasket for ailerons and flaps. Install the control horns and gaskets in aileron and flap slots as shown and screw in place.

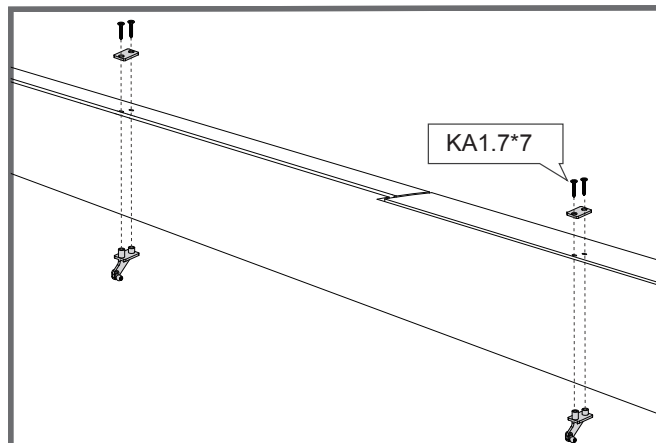

2. Make sure the servos are in neutral position. Attach the flap and aileron linkage rods to the corresponding holes in the flap and aileron control arms from the outside as shown (Please refer to the control horn and servo arm settings in manual). And then install the ball buckle at the other end of the linkage rods to the ball head at each control horn on control surfaces.

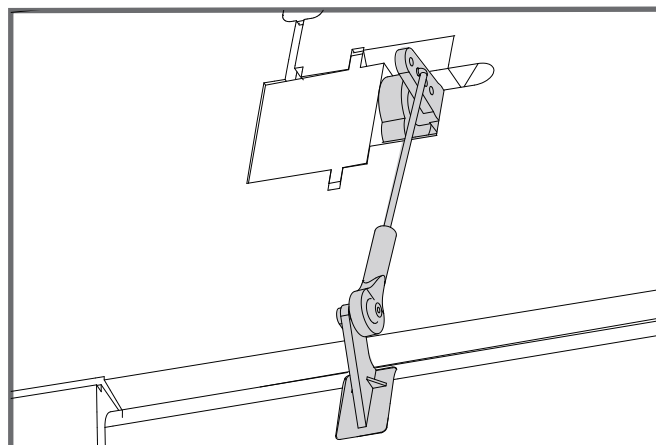
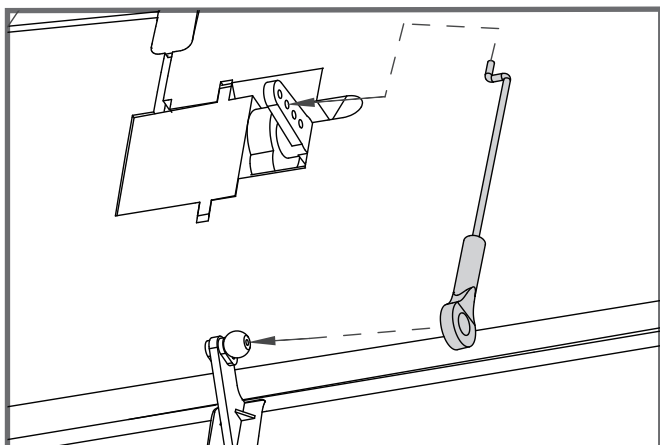

### Main wing installation

1. Slide the tube into the fuselage.

**Notice:** Loosen the screws at the shown positions before applying the wing tube.

2. Install both wing halves over the wing tube and into the wing slot of the fuselage.

**Notice:** Connect CH1, CH6, to Y harness.

3. Secure the screws in place as shown.

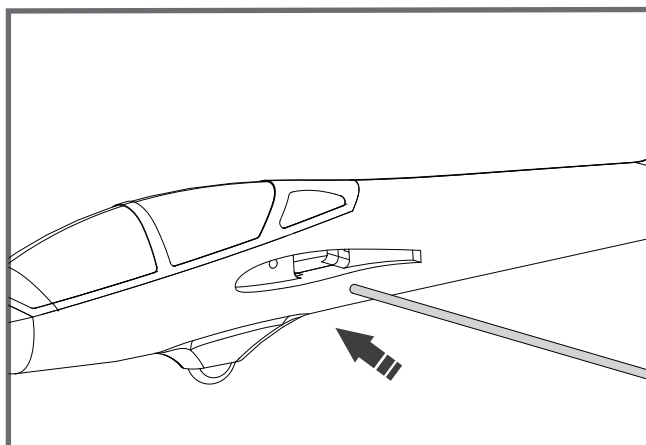

## Model assembly

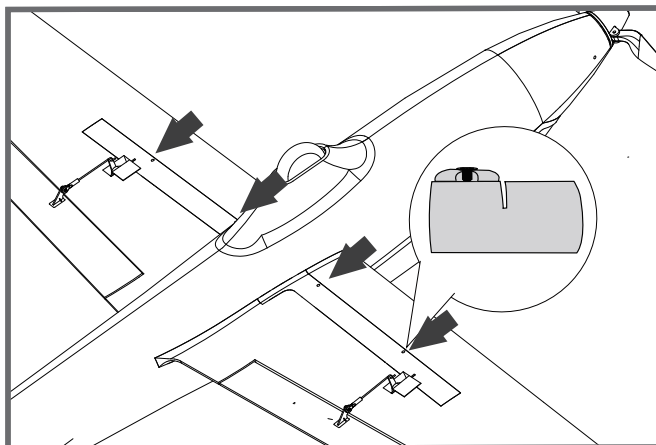
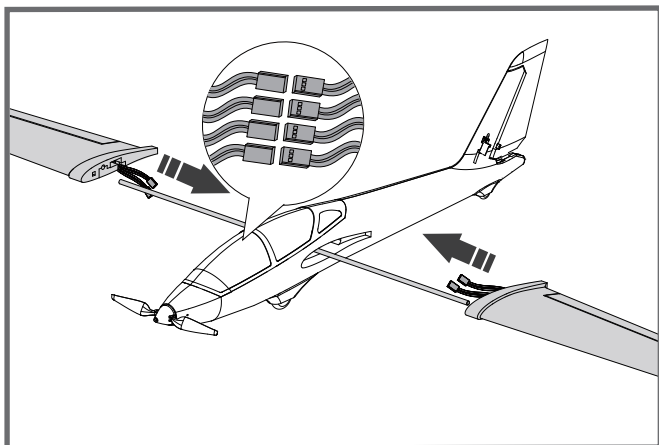

### Horizontal stabilizer installation

1. Take out the control horn and gasket for elevator from the accessory bag. Install the control horn and gasket in elevator slot as shown and screw in place.
2. Install the horizontal tail to the bottom slot of the vertical tail as shown, and secure it in place using the attached screws.
3. Apply the elevator linkage rod to control horn (referring to the installation method of flap and aileron linkage rods).

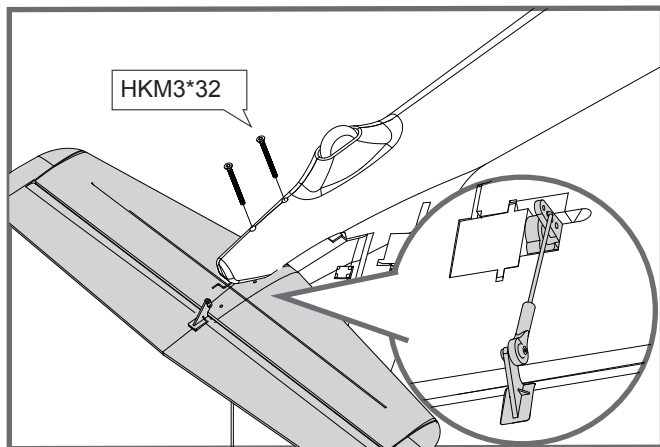
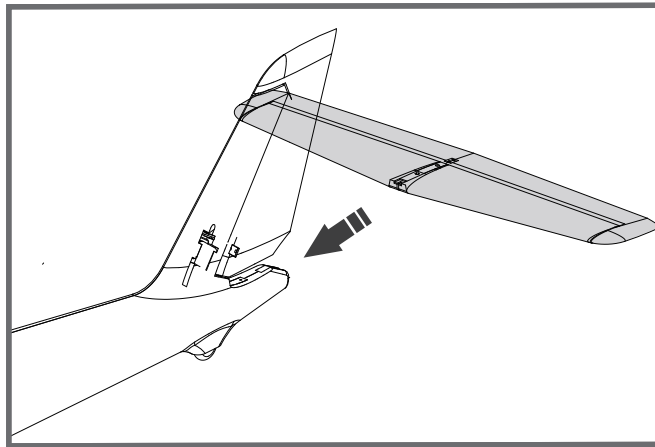
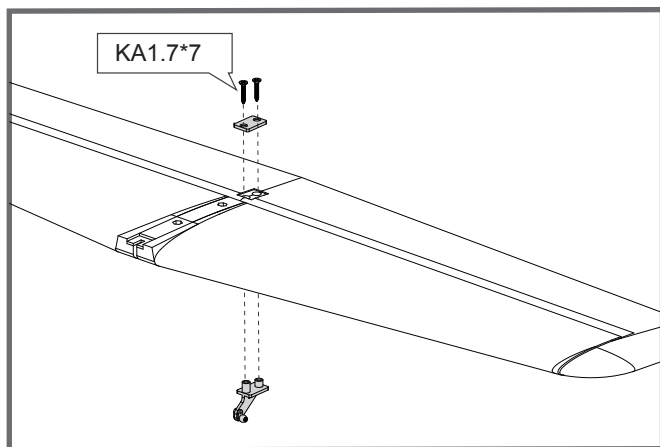

# Model assembly

## Vertical stabilizer installation

1. Take out the control horn and gasket for rudder from the accessory bag. Install the control horn and gasket in rudder slot as shown and screw in place.
2. Apply the rudder linkage rod to control horn (referring to the installation method of flap and aileron linkage rods).

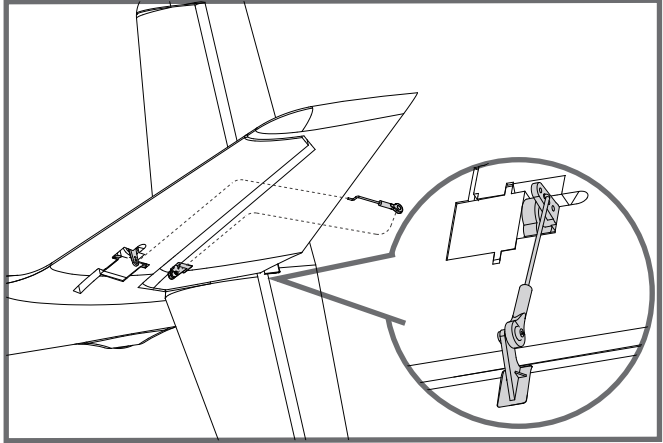
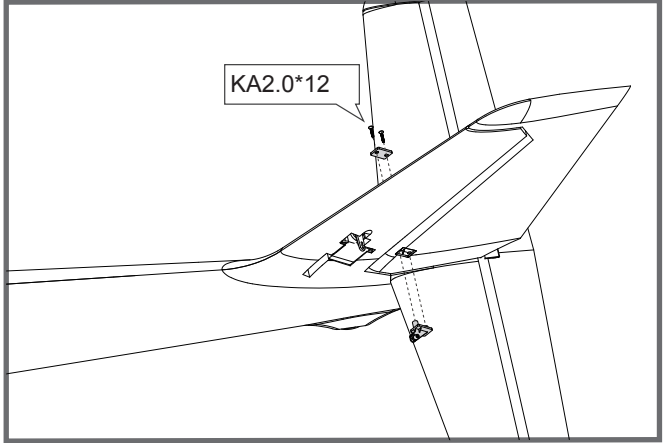

## Battery installation

1. Pull back on the latch and remove the battery hatch.
2. Apply the hook tape to the cable end of the battery.
3. Slide the fully charged battery into the battery compartment with the power supply cable toward the rear end of the plane.

Note: The center of gravity can be adjusted by moving the battery forward or aft. Having the correct center of gravity is critical to achieving proper flight characteristics.

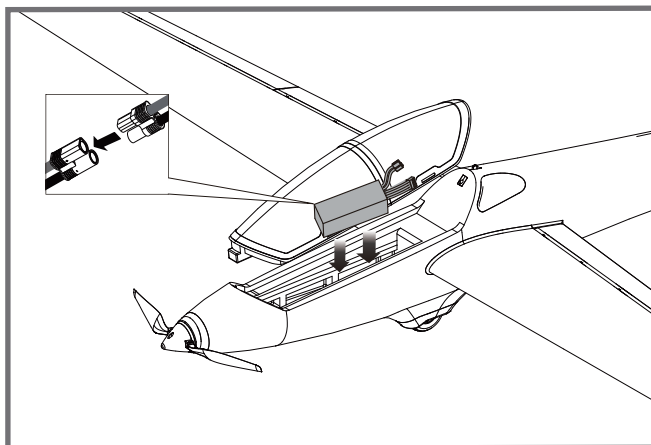

## Receiver diagram

The cables from the servo connector board should be connected to your receiver in the order shown. Note that the LEDs can be powered by any spare channel on the receiver. Tuck the wire leads into the recessed cavity towards the rear of the battery hatch.

		Receiver
Gear	1	Channel-1 — Aile
Elevator	2	Channel-2 — Elev
Throttle	3	Channel-3 — Thro
Rudder	4	Channel-4 — Rudd
Flap	6	Channel-6 — Flap

## Get your model ready to fly

### Important ESC and model information

1. The ESC included with the model has a safe start. If the motor battery is connected to the ESC and the throttle stick is not in the low throttle or off position, the motor will not start until the throttle stick is moved to the low throttle or off position. Once the throttle stick is moved to the low throttle or off position, the motor will emit a series of beeps. Several beeps with the same tune means the ESC has detected the cells of the battery. The count of the beeps equals the cells of the battery. The motor is now armed and will start when the throttle is moved.
2. The motor and ESC come pre-connected and the motor rotation should be correct. If for any reason the motor is rotating in the wrong direction, simply reverse two of the three motor wires to change the direction of rotation.
3. The motor has an optional brake setting. The ESC comes with brake switched off and we recommend that the model be flown with the brake off. However, the brake could be accidentally switched on if the motor battery is connected to the ESC while the throttle stick is set at full throttle. To switch the brake off, move the throttle stick to full throttle and plug in the motor battery. The motor will beep one time. Move the throttle stick to low throttle or the off position. The motor is ready to run and the brake will be switched off.
4. Battery Selection and Installation. We recommend the Li-Po 11.1V 1300mAh 25C Li-Po battery. If using another battery, the battery must be at least a Li-Po 11.1V 1300mAh 25C battery. Your battery should be approximately the same capacity, dimension and weight as the Li-Po 11.1V 1300mAh 25C Li-Po battery to fit the fuselage without changing the center of gravity significantly.

# Get your model ready to fly

## Transmitter and model setup

Before getting started, bind your receiver with your transmitter. Please refer to your transmitter manual for proper operation. **CAUTION:** To prevent personal injury, DO NOT install the propeller assembly onto the motor shaft while testing the control surfaces. DO NOT arm the ESC and do not turn on the transmitter until the Transmitter Manual instructs you to do so. Tips: Make sure all control sticks on your radio are in the neutral position (rudder, elevator, ailerons) and the throttle is in the OFF position. Make sure both ailerons move up and down (travel) the same amount. This model tracks well when the left and right ailerons travel the same amount in response to the control stick. Move the controls on the transmitter to make sure the aircraft control surface moves correctly. See diagrams.

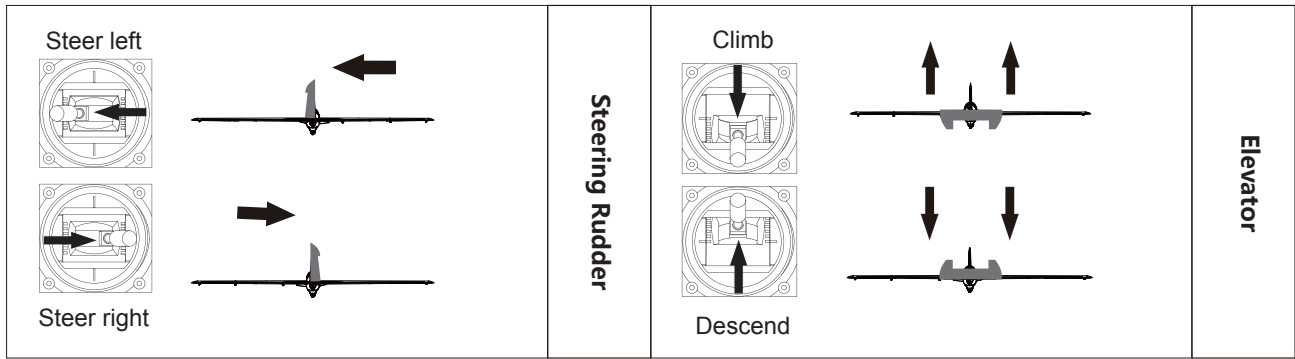
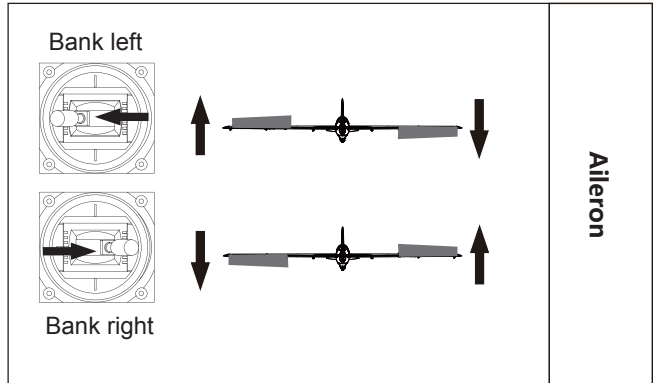

## Control throws

The suggested control throw setting for this airplane are as follows (dual rate setting):

	High Rate	Low Rate
Elevator	20mm up / down	16mm up / down
Aileron	18mm up / down	12mm up / down
Rudder	24mm left / right	20mm left / right
Flap	35mm up / down	30mm up / down

Tips: On the first flight, fly the model in low rate. The first time you use high rates, be sure to fly at low to medium speeds. High rate, as listed, is only for EXTREME maneuvering.

## Clevis installation



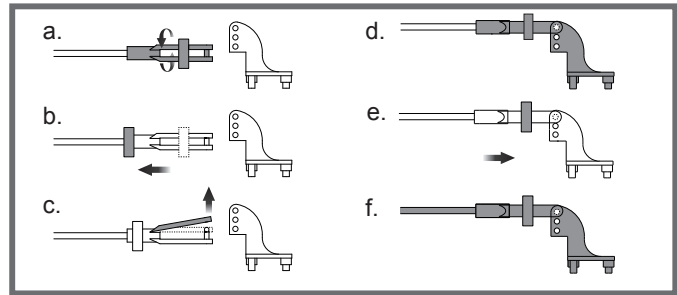





1. Pull the tube from the clevis to the linkage.
2. Carefully spread the clevis, then insert the clevis pin into the desired hole in the control horn.
3. Move the tube to hold the clevis on the control horn.

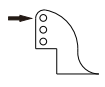

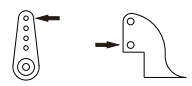
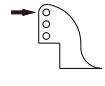

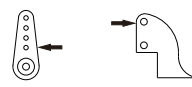
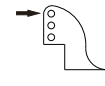
## Control horn and servo arm settings

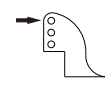
The table shows the factory settings for the control horns and servo arms. Fly the aircraft at the factory settings before making changes. After flying, you may choose to adjust the linkage positions for the desired control response.

	Horns	Arms	More control throw
Elevator			
Rudder			
Ailerons			
Flap			

## Check the C.G. (Center of gravity)

When balancing your model, adjust the battery as necessary so the model is level or slightly nose down. This is the correct balance point for your model. After the first flight, the CG position can be adjusted for your personal preference.

1. The recommended Center of Gravity (CG) location for your model is 40mm from the leading edge of the main wing (as shown) with the battery pack installed. Mark the location of the CG on top of the wing.

2. When balancing your model, support the plane at the marks made on the bottom of the main wing with your fingers or a commercially available balancing stand. This is the correct balance point for your model. Make sure the model is assembled and ready for flight before balancing.

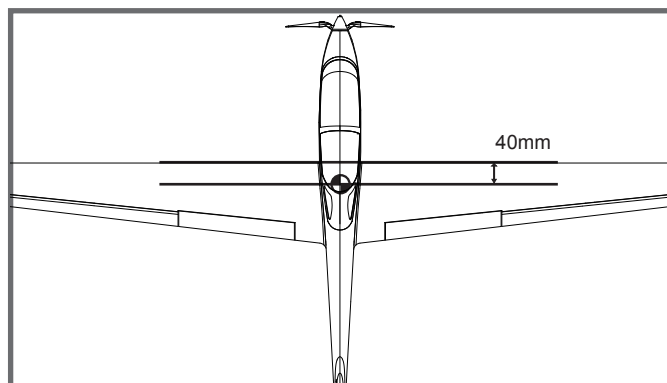

## Before flying the model

### Find a suitable flying site

Find a flying site clear of buildings, trees, power lines and other obstructions. Until you know how much area will be required and have mastered flying your plane in confined spaces, choose a site which is at least the size of two to three football fields - a flying field specifically for R/C planes is best.

Never fly near people - especially children, who can wander unpredictably.

### Perform the range check for your plane

As a precaution, an operational ground range test should be performed before the first flight each time you go out. Performing a range test is a good way to detect problems that could cause loss of control such as low batteries, defective or damaged radio components, or radio interference. This usually requires an assistant and should be done at the actual flying site you will be using.

First turn on the transmitter, then install a fully-charged battery into the fuselage. Connect the battery and install the hatch. Remember, use care not to bump the throttle stick. Otherwise, the propeller/fan will turn and possibly cause damage or injury.

**Note:** Please refer to your Transmitter Manual that came with your radio control system to perform a ground range check. If the controls are not working correctly or if anything seems wrong, do not fly the model until you correct the problem. Make certain all the servo wires are securely connected to the receiver and the transmitter batteries have a good connection.

## Before flying the model

### Monitor your flight time

Monitor and limit your flight time using a timer (such as on a wristwatch or in your transmitter if available). When the batteries are getting low you will usually notice a performance drop before the ESC cuts off motor power, so when the plane starts flying slower you should land. Often (but not always) power can be briefly restored after the motor cuts off by holding the throttle stick all the way down for a few seconds. To avoid an unexpected dead-stick landing on your first flight, set your timer to a conservative 4 minutes. When your alarm sounds you should land right away.

## Flying course

### Take off

While applying power, slowly steer to keep the model straight. The model should accelerate quickly. As the model gains flight speed you will want to climb at a steady and even rate. It will climb out at a nice angle of attack (AOA).

### Flying

Always choose a wide-open space for flying your plane. It is ideal for you to fly at a sanctioned flying field. If you are not flying at an approved site always avoid flying near houses, trees, wires and buildings. You should also be careful to avoid flying in areas where there are many people, such as busy parks, schoolyards, or soccer fields. Consult laws and ordinances before choosing a location to fly your aircraft. After takeoff, gain some altitude. Climb to a safe height before trying technical manoeuvres, including high speed passes, inverted flight, loops, and point rolls.

### Landing

Land the model when you hear the motor pulsing (LVC) or if you notice a reduction in power. If using a transmitter with a timer, set the timer so you have enough flight time to make several landing approaches.

The model's three point landing gear allows the model to land on hard surfaces. Align model directly into the wind and fly down to the ground. Fly the airplane down to the ground using 1/4-1/3 throttle to keep enough energy for proper flare. Before the model touches down, always fully decrease the throttle to avoid damaging the propeller or other components. The key to a great landing is to manage the power and elevator all the way to the ground and set down lightly on the main landing gear. After a few flights you will find the model can be set down lightly on the mains and you can hold the nose wheel off balancing the model on the mains until it slows and gently settles the nose.

### Maintenance

Repairs to the foam should be made with foam safe adhesives such as hot glue, foam safe CA, and 5min epoxy. When parts are not repairable, see the Spare Parts List for ordering by item number.

Always check to make sure all screws on the aircraft are tightened. Pay special attention to make sure the spinner is firmly in place before every flight.

## Trouble shooting

Problem	Possible Cause	Solution
Aircraft will not respond to the throttle but responds to other controls.	-ESC is not armed. -Throttle channel is reversed.	-Lower throttle stick and throttle trim to lowest settings. -Reverse throttle channel on transmitter.
Extra propeller noise or extra vibration.	-Damaged spinner, propeller, motor or motor mount. -Loose propeller and spinner parts. -Propellor installed backwards.	-Replace damaged parts. -Tighten parts for propeller adapter, propeller and spinner. -Remove and install propeller correctly.
Reduced flight time or aircraft underpowered.	-Flight battery charge is low. -propeller installed backward. -Flight battery damaged.	-Completely recharge flight battery. -Replace flight battery and follow flight battery instructions.
Control surface does not move, or is slow to respond to control inputs.	-Control surface, control horn, linkage or servo damage. -Wire damaged or connections loose.	-Replace or repair damaged parts and adjust controls. -Do a check of connections for loose wiring.
Controls reversed.	Channels are reversed in the transmitter.	Do the control direction test and adjust controls for aircraft and transmitter.
-Motor loses power -Motor power pulses then motor loses power.	-Damage to motor, or battery. -Loss of power to aircraft. -ESC uses default soft Low Voltage Cutoff(LVC).	-Do a check of batteries, transmitter, receiver, ESC, motor and wiring for damage(replace as needed). -Land aircraft immediately and recharge flight battery.
LED on receiver flashes slowly.	Power loss to receiver.	-Check connection from ESC to receiver. -Check servos for damage. -Check linkages for binding.

## Spare parts list content

FMSMT101	Fuselage	FMSPROP042	Propeller
FMSMT102	Main Wing Set	FMSBMX022	Motor board
FMSMT103	Horizontal Stabilizer	PRKVX900-2	4018 KV900 motor
FMSMT104	Spinner	PRESC002	Predator 30A ESC
FMSMT302	Canopy	FMSSER003	9g digital gear servo positive
FMSMT303	Cockpit		
FMSMT304	Decal sheet		
FMSMT305	Pipe		

# Brushless ESC Introduction

## Important warnings

- ZTW is not responsible for your use of this product, or any damage or injuries you may cause or sustain as a result of its usage.
- Always place safety as priority when you use the product.
- An electric motor that is connected in combination with a battery and/or ESC may start unexpectedly and cause serious damage and so should always be used with care and respect.
- We recommend you always remove the propeller when working on a model with the power source connected.
- Follow and observe all local laws and by-laws relating to model flying when flying RC planes.
- Never fly over others or near crowds.

## Key features

1. Utilizes powerful next generation MOSFET with a low thermal signature, high peak current threshold and reliability.
2. Features high performance 32bit microprocessor as standard. Stronger computing ability and faster processing rates.
3. Super smooth start up and throttle throughout the power range.
4. Higher driving efficiency and more energy-saving.
5. Adjustable SBEC output voltage, 5V/6V. (40A/50A/60A/80A/100A have SBEC adjustable)
6. Multiple protection protocols: start-up, over-heat, low-voltage cutoff, signal loss, phase loss etc.
7. Supports wide range of high RPM type motors commonly found in today's market.
8. Fully programmable via optional ZTW mobile app or ZTW LCD programming card.

## Specification

Type	PN#Model	Cont./Burst Current(A)	Battery cell NiXXLipo	Weight (g)	BEC Output	Size(mm) L*W*H	User Program
Beatles 20A SBEC G2	3020211	20A/30A	5-12NC/2-4Lipo	25	5.5V/4A	60*25*10	Yes
Beatles 30A SBEC G2	3030211	30A/40A	5-12NC/2-4Lipo	25	5.5V/4A	60*25*10	Yes
Beatles 40A SBEC G2	3040211	40A/55A	5-12NC/2-4Lipo	37	5V/6V 4A	68*25*10	Yes
Beatles 50A SBEC G2	3050211	50A/65A	5-12NC/2-4Lipo	37	5V/6V 4A	68*25*10	Yes
Beatles 60A SBEC G2	3060211	60A/80A	5-18NC/2-6Lipo	50	5V/6V 8A	70*34*10	Yes
Beatles 80A SBEC G2	3080211	80A/100A	5-18NC/2-6Lipo	75	5V/6V 8A	90*37*10	Yes
Beatles 100A SBEC G2	30100211	100A/120A	5-18NC/2-6Lipo	80	5V/6V 8A	90*37*10	Yes

### Wires Connection:

The speed controller can be connected to the motor by soldering directly or with high quality connectors. Always use new connectors, which should be soldered carefully to the cables and insulated with heat shrink tube. The maximum length of the battery pack wires shall be within 6 inches.

- Solder controller to the motor wires.
- Solder appropriate connectors to the battery wires.
- Insulate all solder connectors with heat shrink tubes.
- Plug the "JR" connector into the receiver throttle channel.
- Controller Red and Black wires connects to battery pack Red and Black wires respectively.

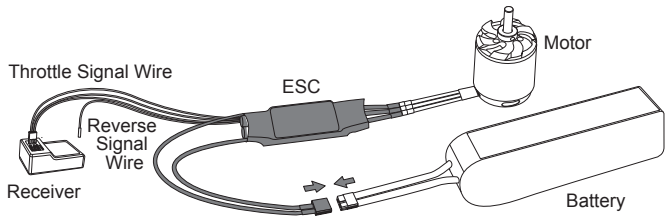

## Brushless ESC Introduction

### Throttle calibration

(Important: Please make the throttle calibration for the first time using ESC!!!)

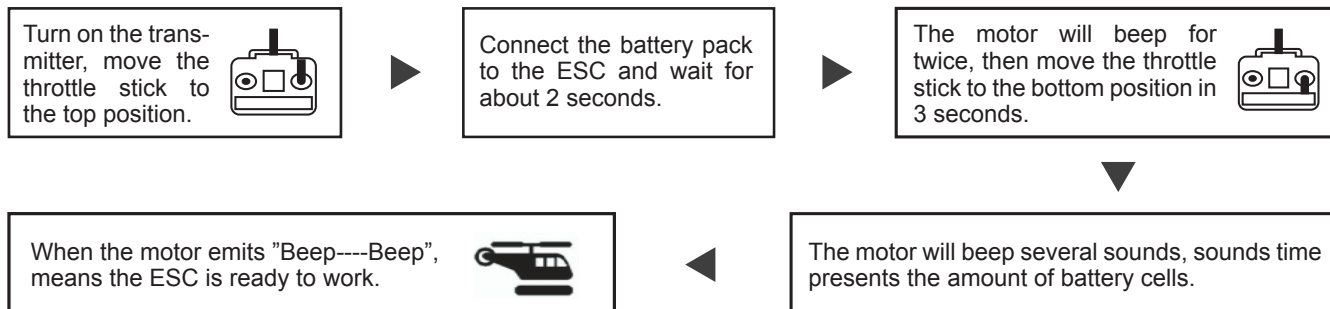

### Normal startup procedure

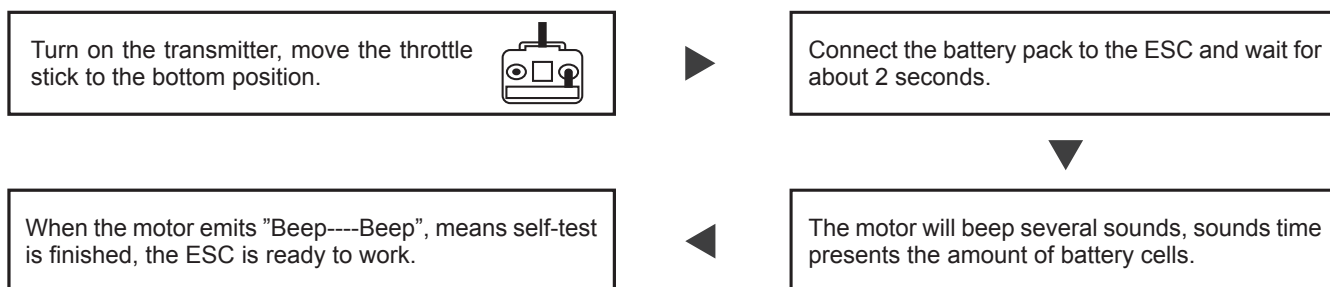

### Programming items(the option written in bold font is the default setting)

#### 1. SMR Function: **OFF**/ON

This function supports switching the motor rotation to decelerate when the airplane landing to the ground. The factory default is OFF, the 1Pin signal wire is completely invalid at this time. If you need to turn it on, using Phone App or transmitter to program it "ON", plug the 3Pin signal wire into the throttle channel, and plug the 1Pin signal wire into any 2-stage switch channel of the receiver, then turn on the transmitter 2-stage switch. The SMR function is turned on now, you can change the forward and reverse directions of the motor by flipping the 2-stage switch of the transmitter.

**Warning:** This function can only be effective when the throttle is below 50%, and it is only allowed to be used when the airplane is landing on the ground, otherwise it may cause the ESC to burn!

#### 2. Brake Type: **OFF**/Soft/Mid/Hard

#### 3. Timing: **Auto**/Low/Mid/High(5°/15°/25°)

#### 4. Motor Rotation: **CW**/CCW

#### 5. SR function: ON/**OFF**

The synchronous rectification function makes ESC with higher driving efficiency and more energy-saving.

#### 6. Battery cells: **Auto**/2S/3S/4S/5S/6S

#### 7. Low Voltage Cutoff Threshold: OFF/NIMH50%/NIMH60%/**3.0V**/3.2V/3.4V/3.6V

For example: using 3 lithium batteries and setting 3.0V as the low voltage cutoff value, then the low voltage protection threshold is:  $3 \times 3.0 = 9.0V$

#### 8. Low Voltage Cutoff Type: **Reduce Power**/Cut Off Power

Reduced power: When the voltage drops to the set low-voltage protection threshold, the ESC will reduce power to 70%.

## Brushless ESC Introduction

### Programming tone reference table

Items \ Tones	"beep"	"beep.beep"	"beep.beep .beep"	"beep.beep .beep.beep"	"beep- -"	"beep- - beep"	"beep- - beep.beep"
	1short tone	2short tone	3short tone	4short tone	1long	1long 1short	1long 2short
SMR Function	<b>*OFF</b>	ON					
Brake Type	<b>*OFF</b>	Soft Brake	Mid Brake	Mid Brake			
Motor Timing	<b>*Auto</b>	Low	Mid	Mid			
Motor Rotation	<b>*CW</b>	CCW					
SR Function	ON	<b>*OFF</b>					
Battery Cells	<b>*Auto</b>	2S	3S	4S	5S	6S	
Low voltage Cutoff Threshold	OFF	NIMH50%	NIMH60%	<b>*3.0V</b>	3.2V	3.4V	3.6V
Low Voltage Cutoff Type	<b>*Reduce Power</b>	Cut off Power					
SMR Function	<b>*5V</b>	6V					
Brake Type	<b>*Normal</b>	Soft					
Restore Factory Default Sets	Restore						

Note: " \* " value means default settings.

### Protection function

1. Start-up protection: If the motor fails to start normally within 2 seconds after pushing the throttle to start, the ESC will cut off the output power, and you need to make the throttle calibration again, then ESC can be restarted. Possible reasons: disconnection or poor connection between ESC and motor, the propeller or motor is blocked by other objects, the gearbox is damaged, etc.)
2. Over-heat protection: When the temperature of the ESC is over about 110℃, the ESC will automatically reduce the output power for protection, but will not fully shut down the power, reduce it to 70% of the full power at most to ensure the motor has enough power to avoid crashes.
3. Throttle signal loss protection: The ESC will reduce the output power if throttle signal is lost for 1 second, will cut off output to the motor if the throttle signal is lost over 2 seconds. If the throttle signal recovers during power down, the ESC will immediately resume throttle control. In this way, the ESC will not protect when the signal loss less than 2 seconds, only when the signal lost is over 2 seconds or longer time. And the ESC will reduce the output power gradually instead of cutting off it immediately, so the player has certain amount of time to save the plane, taking into account safety and practicality.
4. Over load protection: The ESC will cut off power or restart automatically when the load increased a lot suddenly, possible reason is the motor blocked.

## Brushless ESC Introduction

### Trouble shooting

Trouble	Possible Reason	Action
After powering up, ESC emits the sound of battery cells, but motor can't run.	ESC doesn't set throttle range.	Set throttle range again.
After powering up, motor doesn't run and doesn't emit any sound.	<ol style="list-style-type: none"> <li>1.Bad connection between ESC and battery.</li> <li>2.Bad soldering cause bad contact.</li> <li>3.Low voltage of the battery.</li> <li>4.Quality problem of ESC.</li> </ol>	<ol style="list-style-type: none"> <li>1.Clean the connectors or replace them, check the connection polarity.</li> <li>2.Solder the wires again.</li> <li>3.Check battery pack, use full-charged battery.</li> <li>4.Change ESC.</li> </ol>
Motor does n't work and no audible tone emitted after connecting the battery. Servos are not working either.	<ol style="list-style-type: none"> <li>1. Poor/loose Connection between battery Pack and ESC.</li> <li>2. No power.</li> <li>3. Poor soldered connections.</li> <li>4. Wrong battery cable polarity.</li> <li>5. ESC throttle cable connected to receiver in the reverse polarity.</li> </ol>	Check all the connections make sure you are doing it right.
Motor does not work but servos do.	<ol style="list-style-type: none"> <li>1.Poor/loose connection between ESC and motor.</li> <li>2. Burnt motor coils.</li> <li>3. The battery pack voltage exceeds the acceptable range.</li> <li>4. Throttle stick is not at the lowest position.</li> <li>5. The ESC throttle calibration has not set up.</li> </ol>	<ol style="list-style-type: none"> <li>1. Check all the connections make sure you are doing it right.</li> <li>2. Change a new motor.</li> <li>3. Solder the wires again.</li> <li>4. Check the battery pack, use full-charged battery.</li> <li>5. Set throttle range again.</li> </ol>
When the ESC is powered on, the motor does not work and an alarm sound (continuously beeping) will sound.	The throttle stick is not in the bottom position after power on.	Move the throttle stick to the bottom position.
Motor runs in reverse rotation.	Wrong cables polarity between the ESC and the motor.	Swap any two of the three cable connections between the ESC and the Motor or access the Motor Rotation function via the ESC programming mode and change the pre-set parameters.
Motor stops running in flight.	Lost throttle signal.	<p>Check proper operation of the radio equipment.</p> <p>Check the placement of the ESC and the Receiver and check the route of the receiver's aerial and ESC.</p>

## 警告



警告：在组装、调整及飞行前请务必认真阅读产品说明书以熟知产品的特性。请严格按照说明书提示进行飞机的组装、调整及飞行。如操作不当会造成产品本身损坏及其它财产损失，甚至造成严重的人身伤害。

声明：模型不是玩具，具有一定的危险性，操作者需要具备一定的飞行经验，初学者请在专业人士指导下操作。禁止十四岁以下儿童操作、飞行。

## 安全须知

本产品飞行由无线电遥控器控制，在飞行过程中可能会受到外界强信号源干扰而导致失控，甚至坠机。因此，在飞行过程中务必始终与飞机保持一定的安全距离，避免意外碰撞、受伤。

- 请勿在发射器电池低电量的情况下操纵模型飞机。
- 请勿在公路、人群、高压线密集区、机场附近及其它法律法规明确禁止飞行的场合飞行。
- 请勿在雷雨、大风、大雪或者其它恶劣气象环境下飞行。
- 请严格遵照产品指导说明及安全警告操作本产品及其相关配置（例如充电器、电池等）。
- 请勿将相关化工类产品、零部件、电子部件等置于儿童可触及的范围。
- 请勿将电子件暴露于潮湿的环境中，以免造成损坏。
- 请勿将本品任意处置于口中，以免造成人身伤亡。

## 锂聚合物电池使用安全须知

- 使用锂聚合物电池时，须严格遵守制造商说明、要求并了解相关风险，使用不当会导致锂聚合物电池起火，从而造成严重的财产损失甚至人身伤害。
- 禁止使用变形、胀气的锂聚合物电池。
- 禁止使用过充、放电的锂聚合物电池，避免发生危险。长时间不使用须将锂聚合物电池放电至存储电压（3.8~3.85V / 节）。锂聚合物电池须储存在室内干燥区域（4.5~48.5℃），禁止将锂聚合物电池置于阳光下暴晒或车内，高温可能会导致锂聚合物电池起火，造成财产损失和人身伤害。
- 请使用专用充电器对锂聚合物电池进行充放电，禁止使用其它如：镍氢电池充电器。充放电时，禁止将锂电池放置于高温物体表面，建议使用锂电池防爆袋。不正确的充放电操作会对锂聚合物电池造成损伤，甚至会引起火灾，造成财产损失和人身伤害。
- 禁止将锂聚合物电池单节电压放至低于 3V，禁止给已损坏的锂聚合物电池充电。
- 锂聚合物电池充放电须在有人看管的情况下进行，避免发生意外造成不必要的损失。

### 飞机电池充电警告：

请确保使用合格的电池充电器给锂电池充电。在使用充电器前，请认真阅读充电器说明书。充电过程中，请确保把电池置于耐热的表面。建议把锂电池置于防火充电袋内充电，防火充电袋可在相关模型实体店或网上买到。



## 产品特点

MDM FOX是一款特技滑翔机，它在第一次公开亮相时，就在世界锦标赛中获得了第一名！从那时起，它就成为了世界各地领奖台上的常规飞机。

FMS 2300mm FOX采用高弹性EPO泡沫，高质量模具造就完美外形，组合动力丰沛的无刷电机和锂电池，给初学者一个更高级别的体验！FOX机翼、平尾、垂尾内置加强管和加强片，有效增加机体强度。此外，坚固结实的机体结构免去玩家暴力飞行的后顾之忧。

FOX V2在初版的基础上做了诸多改进，如增加襟翼功能、使用虚位较小的球头连接、重新设计电机底座、修整机翼、机身、升降舵等，使FOX得以用更自信的姿态执行各种滑翔动作，进阶成为名副其实的全能型滑翔机。

FOX V2可以轻松做正转、倒转、悬停、定点滚动、倒飞等特技动作，在急速上升飞行和坡度飞行方面也有不俗的表现，适合更多玩家操控。

特点：

1. 电子配置：电机4018-KV900，电调30A（带刹车功能），9g舵机X6；
2. 机翼、平尾、垂尾内置加强管或加强片，有效增加机翼强度；
3. 球头扣连杆代替传统U型夹，大大减少动作虚位；
4. 超大2300mm翼展确保飞行的稳定性和时长，更易于飞行拍摄；
5. 可拆卸机翼便于运输和存放；
6. 轻质耐摔的EPO泡沫材质。

## 目录

产品特点	17
产品组成	17
机体安装	18
电池安装	20
接收机连接示意图	21
遥控器设置	21
夹头安装方式	22
舵角和舵机摇臂安装	22
重心调整	22
飞行前准备	22
故障检修指导	23
配件列表	23
电调使用说明	24

## 产品组成

在组装产品之前，请仔细检查以下配件，如有缺失或者损坏，请及时联系当地店面或者邮件至厂家（support@fmsmodel.com），告知缺失或损坏的配件名称及编码（请在本说明书尾页查看相应的配件编码）。请注意，不同配置，包装盒内部物品不同。

### 产品参数

翼展: 2320毫米
机身长: 1290毫米
飞行重量: 大约1150克
电机: 无刷4018-KV900
翼载荷: 30.7g/dm <sup>2</sup>
翼面积: 37.5dm <sup>2</sup>
电调: 30A
舵机: 9g*6
电池: 11.1V 1300mAh 25C

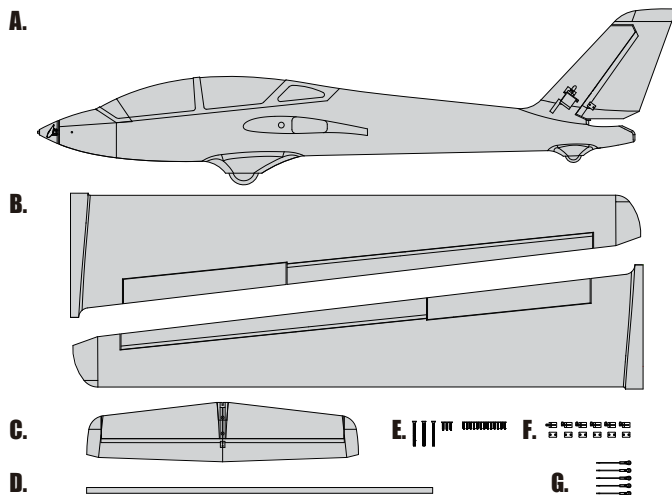

A: 机身 B: 主翼 C: 平尾 D: 主翼连接管  
E: 螺丝组 (KA1.7\*7x13、HKM3\*32x3、KA2.0\*12x3)  
F: 舵角和垫片 G: 连接钢丝

## 机体安装

### 主翼连接钢丝安装

1. 拆开附件包，取出副翼和襟翼所需的舵角和垫片。如图所示，将舵角和垫片安装在副翼和襟翼槽位，并用螺丝固定到位。

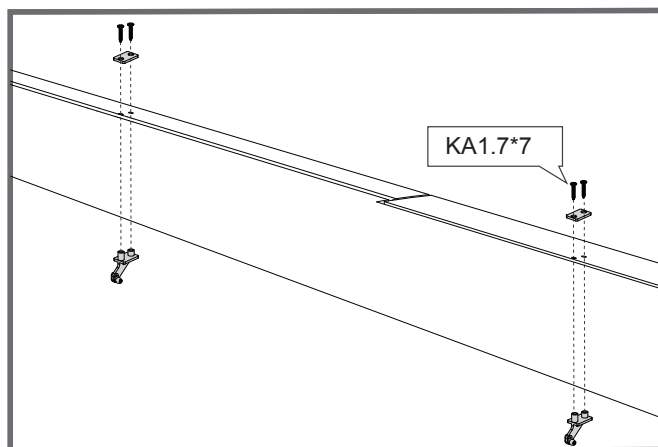

2. 如图所示，保持舵机在回中状态，分别将舵面和副翼舵面的连接钢丝由外侧装入相应的舵机摇臂孔位（请参考舵角和舵机摇臂安装步骤）再将钢丝另一端的球头扣安装到各舵角球头上。

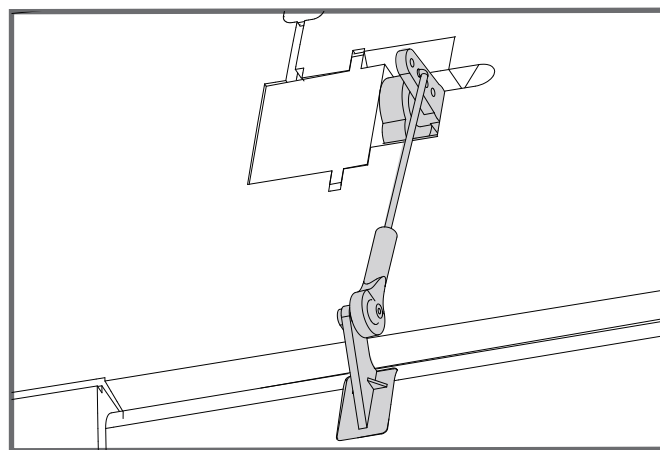
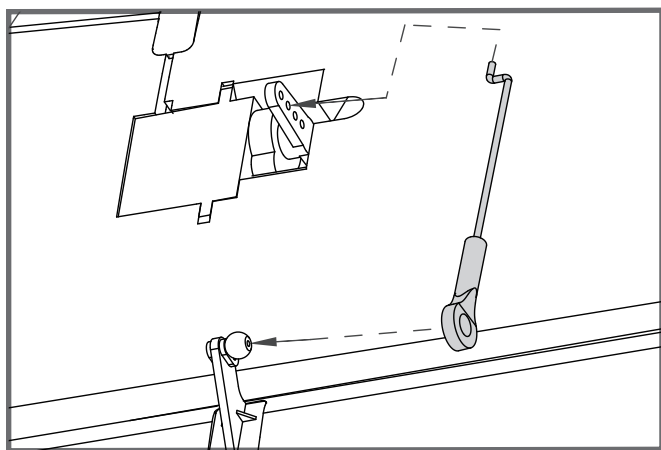

### 主翼安装

1. 将主翼对接管装入图示机身槽位。

注意：安装主翼对接管时需松开箭头所示位置的螺丝。

（螺丝处增加箭头展示）

2. 安装左右两侧机翼至机身。

注意：连接CH1、CH6到Y线上

3. 拧紧螺丝将机翼固定到位。

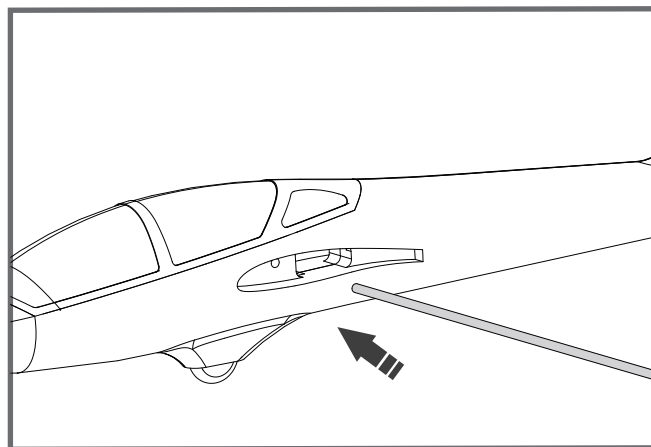

## 机体安装

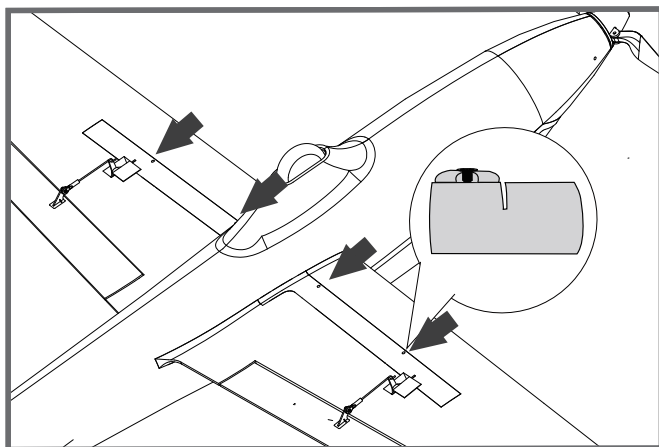
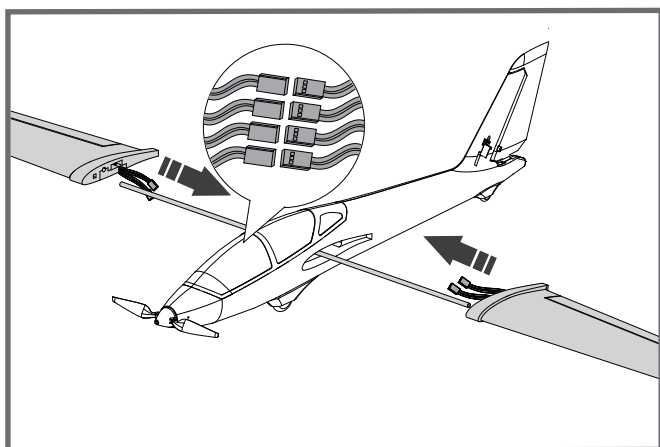

## 平尾安装

1. 取出平尾所需的舵角和垫片。如图示，将舵角和垫片安装在平尾槽位，并用螺丝固定到位。
2. 如图示，将平尾安装至垂尾底部槽位，并使用所附螺丝固定到位。
3. 安装平尾连接钢丝（参考襟翼和副翼连接钢丝的安装方式）

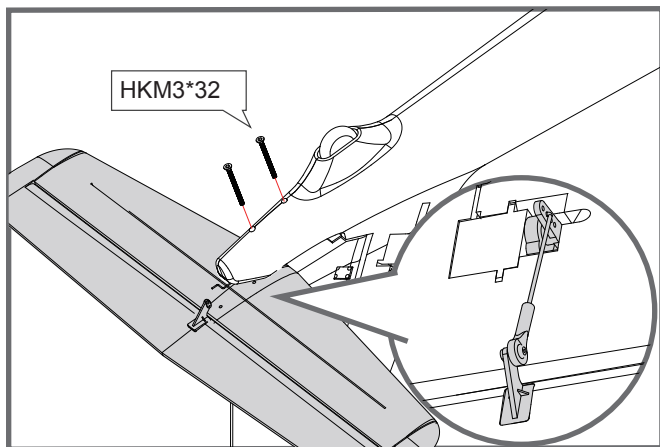
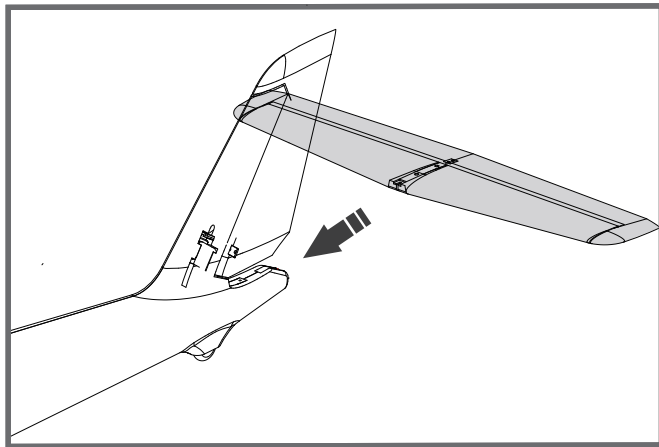
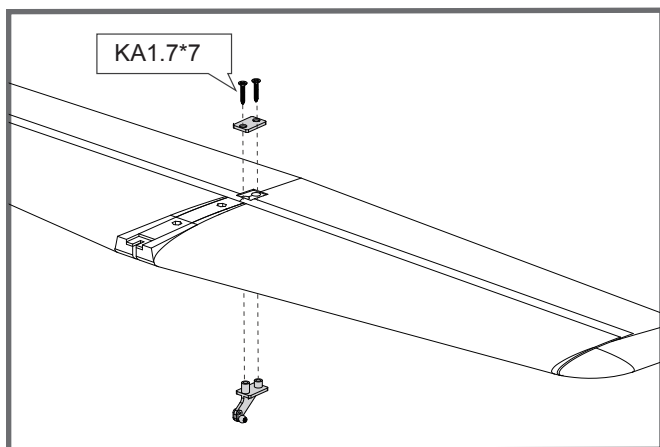

## 机体安装

### 垂尾的连接钢丝安装

1. 取出垂尾所需的舵角和垫片。如图示，将舵角和垫片安装在垂尾槽位，并用螺丝固定到位。
2. 安装垂尾连接钢丝（参考襟翼和副翼连接钢丝的安装方式）

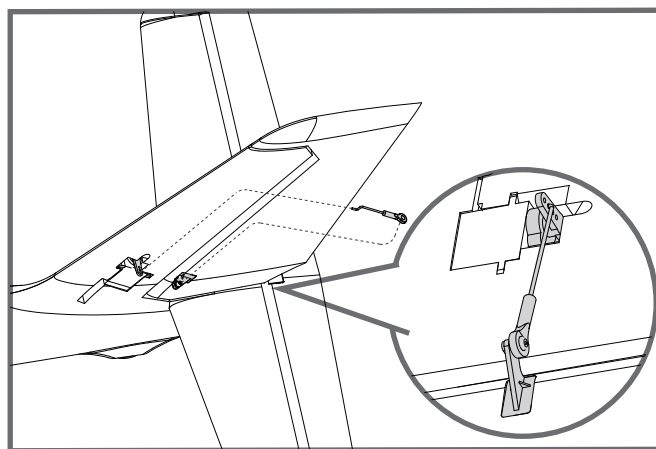
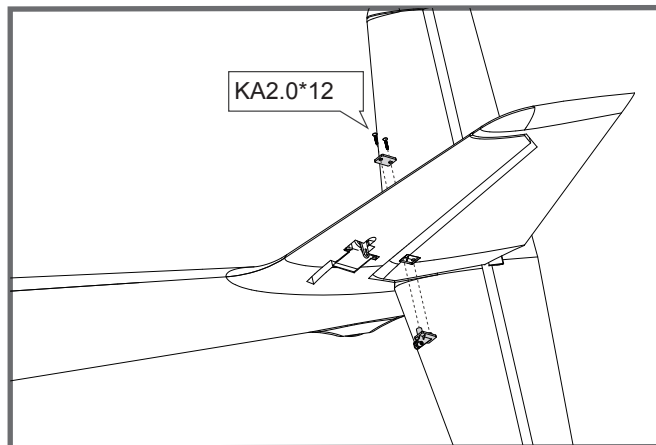

## 电池安装

1. 移开电池盖。
2. 取下电池板上的魔术贴（毛面）贴于电池上面。
3. 如图所示，将电池置于电池舱内，用魔术带绑紧，使有电源线的那端朝向飞机的尾部。

注意：由于不同电池厂家生产的电池重量有轻微的差异，需要调整电池的前后位置来平衡飞机的重心位置。

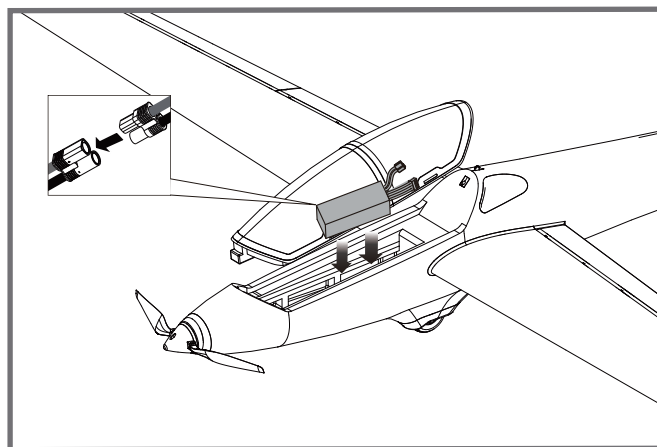

## 接收机连接示意图

如图所示，以Futaba遥控器为例，将舵机信号线按照图示顺序插入接收机通道，将所有连接线整理整齐并固定在电池舱后部的凹槽里，随后固定好接收机。请注意，如产品配有LED，则LED信号线可插入任何闲置通道。

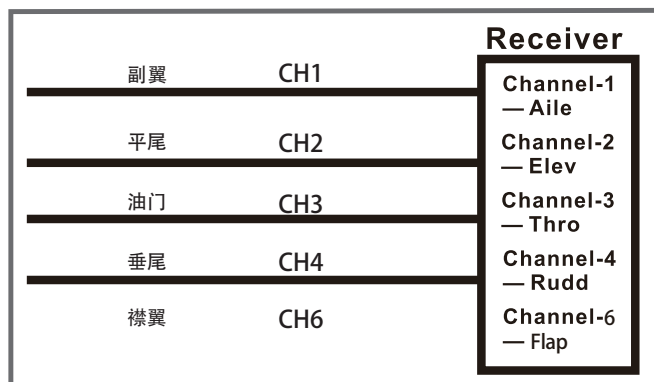

## 遥控器设置

警告：为保证安全，在遥控器参数设置及舵面调整过程中，请务必拆下螺旋桨，以免电机意外启动发生事故。遥控器发射机开机前，确保油门杆在最低位置，其它摇杆在中立位置。开发射机并给接收机通电，随后听到电调初始化音（音符释义见后文“电子调速器说明书”）。观察所有舵面是否回中，如果没有回中，尽量通过调整舵机摇臂角度、连杆长度的方式来使舵面回中，若调整长度在安全范围内仍未回中，则使用遥控器通道微调或者菜单中的“SubTrim”选项来使舵面归中。如下图所示观察摇杆动作与舵面动作的对应关系，如发生舵面反向需要使用遥控器中的通道反向功能来纠正。

1. 移动发射器上的控制杆位置，确保舵面可以自如移动。

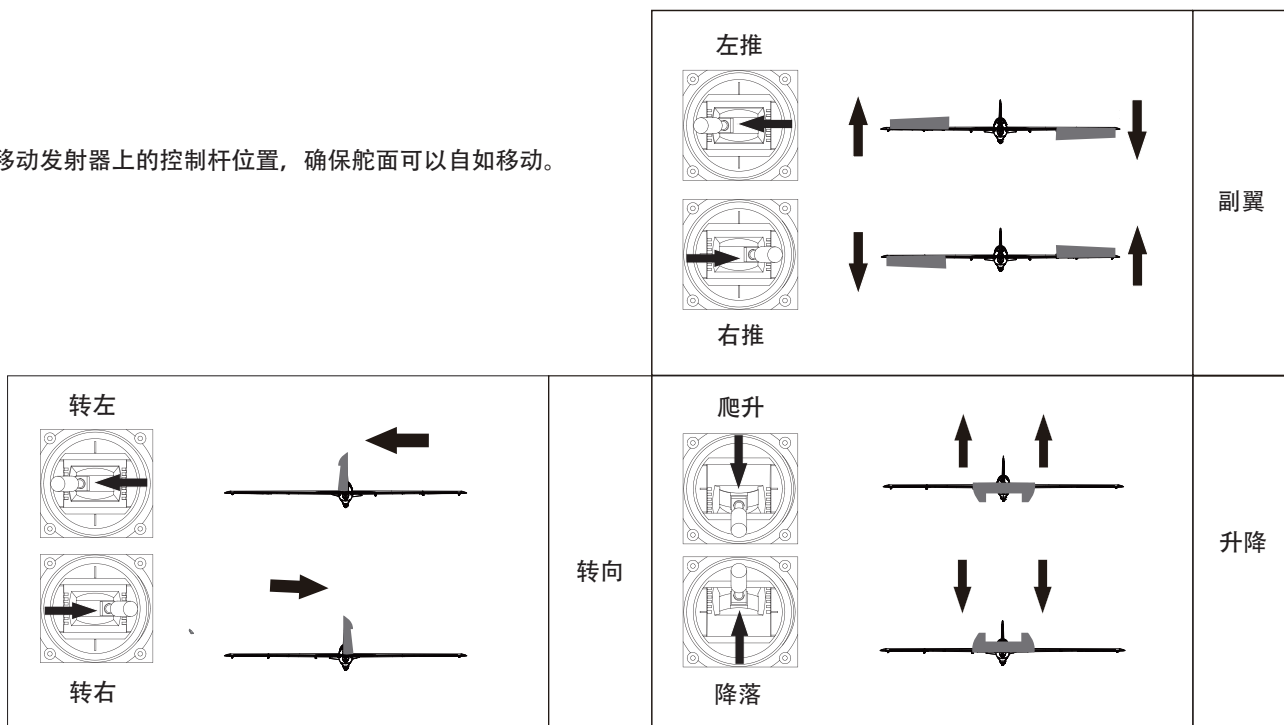

### 推荐舵面行程

温馨提示：首飞建议用小舵面行程

	大	小
升降舵	20mm 上/下	16mm 上/下
副翼舵	18mm 上/下	12mm 上/下
方向舵	24mm 左/右	20mm 左/右
襟翼	35mm 上/下	30mm 上/下

## 夹头安装方式

1. 保证舵机为回中状态，将连接杆夹头调整到合适位置。
2. 将 O 型圈移开，打开夹头，将夹头安装到舵角孔位。
3. 将 O 型圈移回相应位置，锁紧夹头。

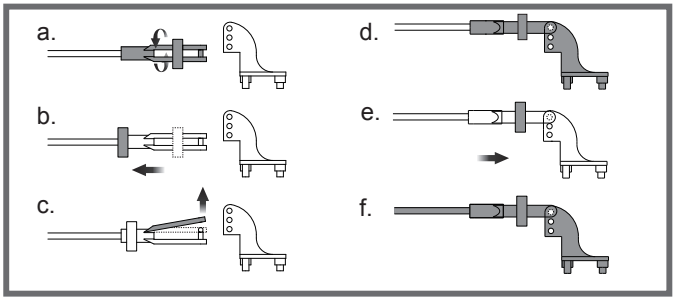

## 舵角和舵机摇臂安装

图示是舵角和舵面摇臂的出厂设置。首飞建议用出厂设置的小舵角飞行。首飞后，可按图调整舵角。

	舵角	摇臂	大舵面
平尾			
垂尾			
副翼			
襟翼			

## 重心调整

通过移动电池在电池舱内的前后位置调整飞机的重心，使飞机保持水平或稍微头重的状态。首飞以后，重心位置可以根据你自己的飞行偏好再做更改。

1. 如图所示，推荐重心位置是机翼前缘往后 40mm 处（安装电池以后）。推荐把食指放在机翼下面的重心位置来帮助调整重心。
2. 在调整飞机重心的时候请确定飞机处于组装完毕待飞的状态。

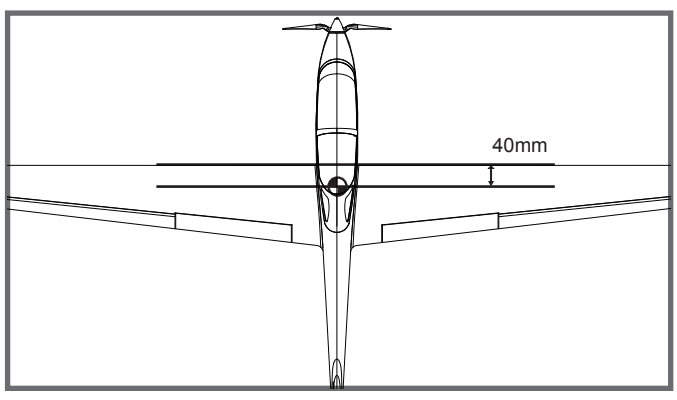

## 飞行前准备

### 起飞前的检查

每次飞行前须做严格的地面检查，可有效避免飞行事故的发生。

1. 检查全机螺丝是否安装到位、舵角摇臂连接可靠。机翼快拆装置已锁紧。
2. 安装电池，并调整飞机重心到说明书推荐位置。
3. 动力电池、遥控器发射机电池等已充满电，处于可靠工作状态。
4. 发射机油门杆保持在最低位（推荐使用带有油门锁定功能的遥控设备），打开发射机，随后连接动力电池，待电调初始化完成后检查各个舵面是否回中，是否动作正确。
5. 轻推油门观察螺旋桨转向是否正确。

所有检查完成后，方可进行飞行，初学者首次飞行需要有经验的爱好者协助完成，避免因操作不当发生飞行事故。

### 合适的飞行场地

航模飞行须远离人群、建筑物、树木、高压线及禁飞区的空旷场地（至少 2-3 个足球场大小）。初学者飞行前需要向有经验的爱者询问相关安全事宜。

## 飞行前准备

### 关于飞行时间

厂家推荐的飞行时间是使用厂家推荐型号的电池，由有经验的爱好者在微风天完成飞行测试得到的飞行时间，该时间与电池参数、飞机全备重量、飞行条件以及飞行手法相关，不同飞行条件可能得到不同的飞行时间。

建议爱好者在飞行时使用遥控器的“计时功能”，建议初始飞行时间设定为 4 分钟，飞行时间倒计时告警后，降落飞机并测量电池电压，方可估算飞行时间并重新调整遥控器计时。如发射机没有计时功能，需要其他设备辅助测算飞行时间，以保证飞行安全。

在电池放电后期，禁止将飞机飞入下风区（风向指向的远端），防止动力不足而导致飞机不能安全返航。

## 故障检修指导

问题	问题原因	解决方式
油门推杆无响应，但舵机有响应	——电调未连接电机 ——油门通道反向	——降低油门推杆和油门微调设定 ——反过来重新装油门通道
桨的噪音过大或者震动过大	——桨罩、桨、电机、电机架坏了 ——桨或者桨罩的小部件松动了 ——桨装反了	——更换损坏的配件 ——把桨、桨夹和桨罩的小部件拧紧 ——反过来重新装桨
飞行时间变短，飞机无力	——电池电量低 ——桨装反了 ——电池坏了	——重新给电池充电 ——依照电池说明书更换新的电池
飞舵面不动，或者动作响应较慢	——舵面、舵角、连接杆、舵机坏了 ——连接线坏了或者接头松了	——更换或者维修坏了的配件 ——检查所有连接线，确保所有接头无松动现象
舵面反向	——遥控器发射机通道反向	——检查通道控制（舵面）方向，调试飞机舵面和遥控器的舵面控制杆
电机无力	——电机或电池坏了 ——电调用了不合适的低压保护装置	——检查电池、发射机、接收机、电调、电机是否有损坏（如有，请及时更换） ——立刻操控飞机降落，重新给电池充电
接收器的 LED 灯慢闪	——接收器低电量	——检查电调和接收器之间的连接 ——检查舵机是否受损 ——检查连接杆是否安装到位

## 配件列表

FMSMT101	机身	FMSPROP042	桨
FMSMT102	主翼	FMSBMX022	电机板V2
FMSMT103	平尾	PRKVX900-2	4018 KV900电机
FMSMT104	桨罩	PRESC002	30A电调
FMSMT302	吸塑座舱	FMSSE003	9g塑胶数码正向舵机
FMSMT303	泡沫座舱		
FMSMT304	贴纸		
FMSMT305	对接管		

# 无刷电子调速器说明

## 安全须知

检验无线电接收装置上的正确设置,第一次测试电调和马达时不要在马达上安装螺旋桨或传动小齿轮。只有当您确认了无线电接收装置上的设置正确后方能安装螺旋桨或传动小齿轮。

- 不要使用裂开或被刺破的蓄电池组电池。
- 不要使用会变得过热的电池组。
- 不要使用短路电池或马达接线端。
- 电缆绝缘要用正确的绝缘材料。
- 使用正确的电缆连接器。
- 电池或伺服系统的数量不要超过电调的规定。
- 错误的电池极性会损坏电调。

## 主要特性

- 1.功率输出元器件(MOSFET)选用新一代的制作工艺,发热低,瞬间承受电流大,可靠性高。
- 2.高性能32位处理器,运算能力更强,运行速度更快。
- 3.超流畅的启动与精准的油门线性。
- 4.效率高,电调更节能,续航时间更长。
- 5.SBEC5V/6V两档可调,持续8A电流供应,给舵机提供更强劲的动力(40A/50A/60A/80A/100A具有SBEC可调)。
- 6.多重保护:启动保护,过温保护,低压保护,缺相保护,信号丢失保护。
- 7.自动识别马达进角,支持高RPM马达,可兼容市面上绝大多数马达。
- 8.支持手机App或LCD编程,操作更简单方便(需单独购买ZTW蓝牙模块或LCD编程卡)。

## 产品规格

型号	PN#Model	持续/瞬时电流(A)	输入电压	重量(g)	BEC输出	尺寸(mm)长*宽*高	是否支持编程
Beatles 20A SBEC G2	3020211	20A/30A	5-12NC/2-4Lipo	25	5.5V/4A	60*25*10	是
Beatles 30A SBEC G2	3030211	30A/40A	5-12NC/2-4Lipo	25	5.5V/4A	60*25*10	是
Beatles 40A SBEC G2	3040211	40A/55A	5-12NC/2-4Lipo	37	5V/6V 4A	68*25*10	是
Beatles 50A SBEC G2	3050211	50A/65A	5-12NC/2-4Lipo	37	5V/6V 4A	68*25*10	是
Beatles 60A SBEC G2	3060211	60A/80A	5-18NC/2-6Lipo	50	5V/6V 8A	70*34*10	是
Beatles 80A SBEC G2	3080211	80A/100A	5-18NC/2-6Lipo	75	5V/6V 8A	90*37*10	是
Beatles 100A SBEC G2	30100211	100A/120A	5-18NC/2-6Lipo	80	5V/6V 8A	90*37*10	是

调速器接线说明(线连接用热缩管收缩使其绝缘,避免短路烧毁调速器)

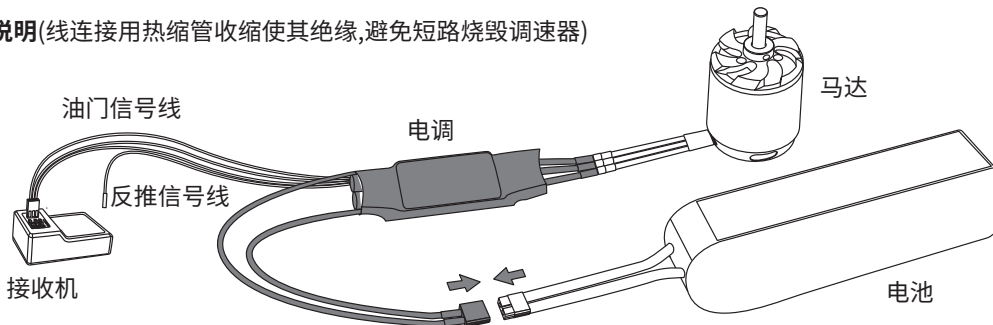



# 无刷电子调速器说明

## 首次使用电调并设置油门行程

温馨提示:在首次使用本电调或更换其他遥控器使用时,请务必先重新设定油门行程。

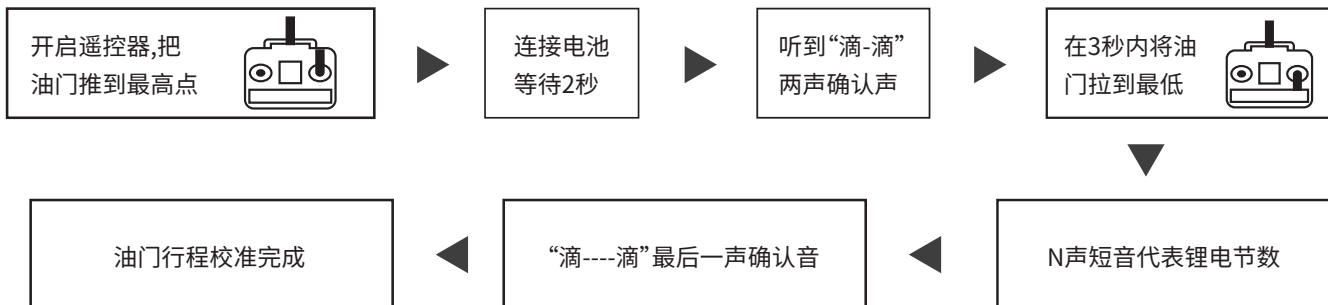

## 首次使用电调并设置油门行程

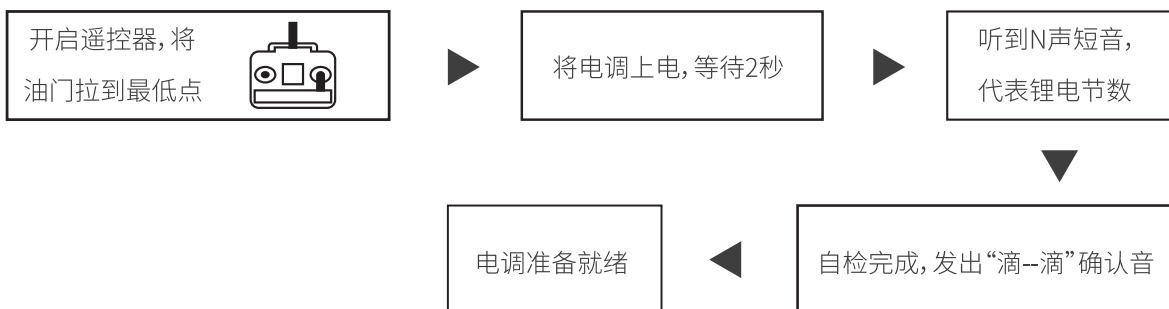

## 编程项简要说明(黑体字为出厂默认值)

### 1. SMR功能: **关闭**/打开

通过切换电机正反向,快速停止。出厂默认是关闭,此时1Pin信号线完全无效。如需打开,通过App设置或遥控器编程打开SMR功能,将3Pin信号线接入油门通道,将1Pin信号线接入接收机任意的2段开关通道,打开遥控器2段开关,此时SMR功能开启,拨动遥控器2段开关即可调整电机正反向。

**警告:**此功能只能在50%油门以下才有效,且只允许在飞机降落至地面使用,否则有可能引起电调烧毁!

### 2. 刹车力度: **关闭**/软/中度/最大

### 3. 进角: **自动**/低/中/高(分别为5度/15度/25度)

### 4. 马达方向: **正向**/反向(正向:电机默认旋转方向,反向:将电机旋转方向更改)

### 5. SR功能: 打开/**关闭**(效率更高,更节能,续航时间更长)

### 6. 锂电节数: **自动**/2S/3S/4S/5S/6S

### 7. 低压保护点: **3.0V**/3.2V/3.4V/3.6V

(例如:使用3节锂电,设定为3.0V为低电压保持值,则低压保护阈值为:3\*3.0=9.0V)

### 8. 保护方式: **降低功率**/立即关断

降低功率:当达到预设的低压保护阈值时,电调减少输出功率至70%

立即关断:当达到预设的低压保护阈值时,电调立即关断输出功率

### 9. BEC: **5V**/6V

40A、50A、60A、80A、100A电调BEC电压输出可设置5V/6V

### 10. 加速度: **普通**/柔和

# 无刷电子调速器说明

## 电子调速器编程设置模式

首先将遥控器油门拉杆推至最高位置,打开遥控器电源,将电池组连接到调速器,2秒后电机"滴-滴滴"声响,停3秒,发出123特殊声音,表示进入编程模式。设置音按以下顺序滚动播放:

- |                 |        |          |
|-----------------|--------|----------|
| 1)。“滴”          | SMR功能  | (1短音)    |
| 2)。“滴.滴”        | 刹车力度   | (2短音)    |
| 3)。“滴.滴.滴”      | 进角     | (3短音)    |
| 4)。“滴.滴.滴.滴”    | 马达转向   | (4短音)    |
| 5)。“滴——”        | SR功能   | (1长音)    |
| 6)。“滴——滴”       | 电池节数   | (1长1短音)  |
| 7)。“滴——滴.滴”     | 低压保护值  | (1长2短音)  |
| 8)。“滴——滴.滴.滴”   | 电压保护类型 | (1长3短音)  |
| 9)。“滴——滴.滴.滴.滴” | BEC输出  | (1长4短音)  |
| 10)。“滴——滴.——”   | 加速度    | (2长音)    |
| 11)。“滴——滴.——滴”  | 恢复出厂默认 | (2长音1短音) |

注:一声长滴相当于五声短滴。

在听到某个提示音后,2S内将油门摇杆打到最低,则进入该设定项,马达会循环鸣叫,在鸣叫某个提示音后将油门摇杆打到最高点,则选择该提示音所对应的设定值,接着会听到123特殊确认音,表示设置成功。

例如:设置马达转向,听到“滴滴滴滴”四短音,表示进入马达转向菜单,在2S内将遥控器油门打到最低,听到“滴”一短音代表正向(CW),“滴滴”两短音代表反向(CCW),如想设置为反向(CCW),则在听到“滴滴”两短音时将油门拉杆打到最高,会听到123特殊确认音,表示设置成功,2秒内将油门拉杆打到最低位置。(如果听到确定音之后,超过2秒油门仍在最高位,则重新进入编程模式)重复以上操作,设置您所需要的各种功能。

退出设定:参数设置成功后,立即将油门拉杆打到最低位置,即表示退出设定。

## 编程参数表

设定项 提示音	“滴”	“滴.滴”	“滴.滴.滴”	“滴.滴.滴.滴”	“滴——”	“滴——滴”	“滴——滴.滴”
	1短音	2短音	3短音	4短音	1长音	1长1短音	1长2短音
SMR功能	关闭	打开					
刹车力度	关闭	软刹车	中度刹车	最大刹车			
进角	自动	低	中	高			
马达转向	正向(CW)	反(CCW)					
SR功能	打开	关闭					
电池节数	自动	2S	3S	4S	5S	6S	
低压保护值	关闭	MIMH50%	NIMH60%	3.0V	3.2V	3.4V	3.6V
电压保护类型	降低功率	立即关断					
BEC输出	5V	6V					
加速度	普通	柔和					
恢复出厂默认	复位						

注:灰颜色为出厂默认选项参数。

# 无刷电子调速器说明

## 保护功能

- 1.启动保护:当推油门启动后,如在两秒内未能正常启动电机,电调将会关闭电机,油门需要重新设置,才可以重新启动。  
可能原因:电调与电机接线断开或接触不良、螺旋桨被其他物体阻挡、减速齿卡死等。
- 2.温度保护:当电子调速器工作温度超过110度时,电调将自动降低输出功率进行保护,但不会将输出功率全部关闭,最多降到全功率的70%,以保证电机留有一定动力,避免摔机。
- 3.油门信号丢失保护:当电调检测到油门信号丢失1秒后,将自动减少对马达的输出功率,然后油门信号丢失超过2秒,电调将自动关断马达。如果在降功率过程中油门信号恢复,电调可以立即恢复油门控制。这样在瞬间信号丢失情况下(2秒以下),电调并不会进行油门保护;只有当遥控信号确实长时间丢失,才进行保护,但电调不是立即关闭输出,而是有一个逐步降低输出功率的过程,给玩家留有一定的救机时间,兼顾安全性和实用性。
- 4.过负荷保护:当负载突然变得很大时,电调会切断动力,或自动重启,出现负载急剧增加的原因通常是马达堵转。

## 常见问题解答

出现的问题	可能的原因	解决方法
接通电调后有自动检测电池节数声音,但马达不能启动	电调没有油门行程设置	对电调进行油门行程设置
马达不工作,连接电池后马达未发音乐声,伺服系统也未运行	电池组与电调之间接触不良 没接通电源 焊接不牢固(接头易断) 电池电缆极性错误 电调信号线与接收机连接极位相反  电调有问题	清理连接器终端或替换连接器 用刚充满电的电池组替换 再次焊接电缆连接 检查并确认电缆极性 检查连接在电调上的信号线以确保处于正确极性  更换电调
马达不工作,连接电池后马达未发出音乐声,但伺服系统在运行接通电调后马达不工作,发出报警音(两声滴滴响后有短暂停顿)	电调与马达之间接触不良 马达线圈被烧 焊接不牢固(接头易断) 电池组电压超出正常范围	检查连接器终端或替换连接器 替换马达 再次焊接电缆连接 更换为刚充满电的电池组,检查电池组电压
接通电调后马达不工作,发出报警音(持续地滴滴响)	通电后油门拉杆不在最小位置	将油门拉杆移至最小位置
接通电调后马达不工作,电调发出两声长响之后,有两声更长点的滴滴响	被颠倒的油门通道导致电调进入程序设计模式	进入发射器上的伺服系统倒转菜单并倒转油门通道
马达反向运行	电调与马达之间错误的电缆连接	交换电调与马达之间三条电缆连接中的任意两条或者通过电调程序设计模式进入马达旋转功能并改变预设参数
飞行过程中,马达停止运行	丢失了油门信号	检查无线电接收装置是否操作得当 检查电调和接收机信号线路及发送频道和电调信号线之间确保有足够的隔离来防止干扰 在电调的信号线上安装一个磁环



Fax:+86-0757-29955904 Tel:+86-0757-29955904

E-mail: support@fmsmodel.com

Add: Unit A, Building 6, Jicheng Science and Technology Innovation Park, Shunde,

Foshan City, Guangdong Province, 528306

Foshan Zhengze Model Technology Co., Ltd.

电话 : 86-0757-29955904

邮箱 : support@fmsmodel.com

地址 : 广东省佛山市顺德区北滘镇顺江社区三乐东路25号集成科创园 6栋

佛山市正泽模型科技有限公司