

EVOLUTION E550

COMMERCIAL FLUIDROWER



FLUIDROWER



The FDF Evolution E550 FluidRower is a high-quality commercial grade rowing ergometer with an instant natural catch and a smooth, consistent feel through the whole stroke. The E550 resistance is provided by the unique semi isokinetic properties of our patented 10 levels Twin Tank Adjustable Fluid Resistance system.

The E550 will cater for the explosive power of any HIIT workout all day every day and yet remains silky smooth at any combination of stroke rate and resistance making it suitable for long cardio sessions, warm ups, cool downs and rehabilitation.

Rowing has long been viewed as an efficient training modality for your whole body; the E550 FluidRower takes this efficiency to new levels. Set the Fluid Resistance to suit you, choose your stroke rate and range of motion and train effectively and efficiently to meet your fitness goals.

The E550 FluidRower has a unique, robust design with the adjustable Fluid Resistance Twin Tank side-mounted, a convenient height rowing seat and a comparatively short frame length. The attractive design provides practical benefits for easy access and minimal floor space requirements.

Every fitness facility needs at least one rowing machine, and the unique versatility of E550 FluidRower makes it the obvious choice.

Partner the E550 FluidRower with FluidExercise Arm Cycle UBE to create motivating individual or group training options.

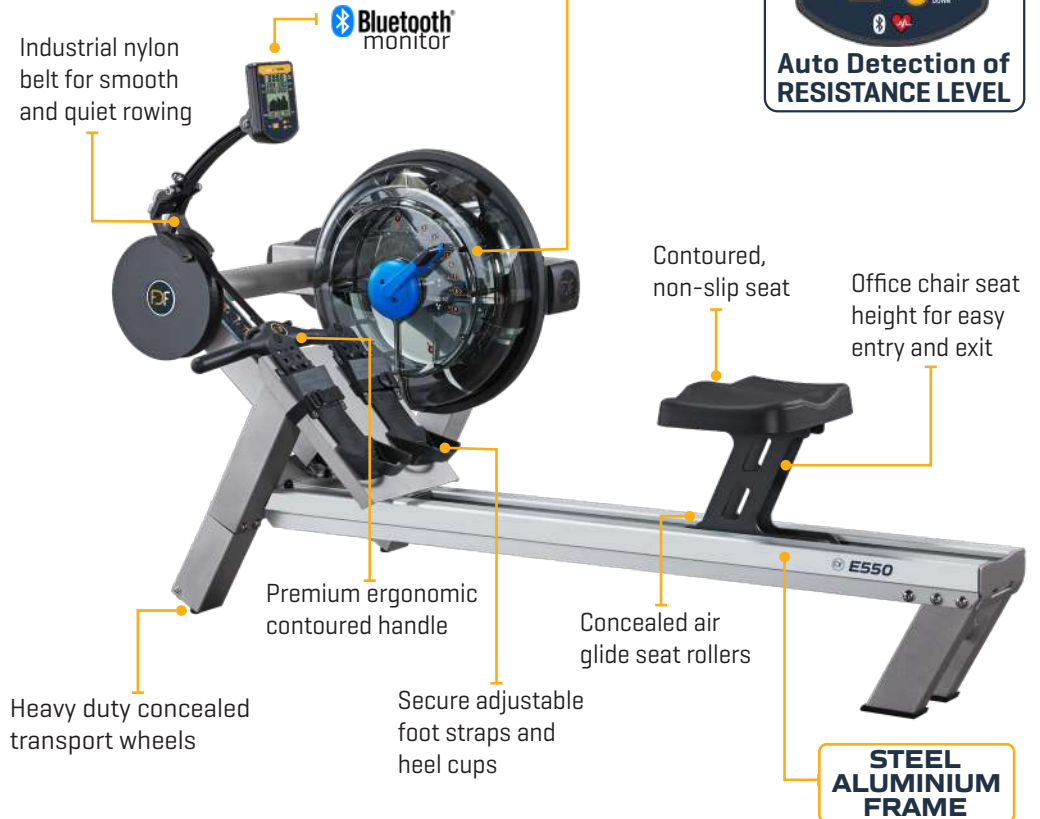

View the full range of rowers at FLUIDROWER.COM

Visit FIRSTDEGREEFITNESS.COM to view all FDF product ranges.

EVOLUTION E550 FLUIDROWER

PRODUCT SPECIFICATIONS

PRODUCT MODEL NO:	E550
FLUID RESISTANCE:	FDF Vertical Twin Tank - 10 Levels
MONITOR:	FDF Bluetooth / Heart Rate Compatible
PRODUCT NET WEIGHT:	61.9kg [136.5lb]
PRODUCT GROSS WEIGHT:	72.5kg [159.8lb]
DIMENSIONS:	L 1,950mm [76.77"] x W 810mm [31.89"] x H 860mm [33.86"]
MIN ACTIVE AREA REQUIRED:	L 2,550mm [100.4"] x W 1,310mm [51.6"]
MAX USER WEIGHT:	150kg [330lb]
COMMERCIAL WARRANTY:	Frame 10 years - Fluid Tank 5 years Mechanical and all other non wearing components - 2 years

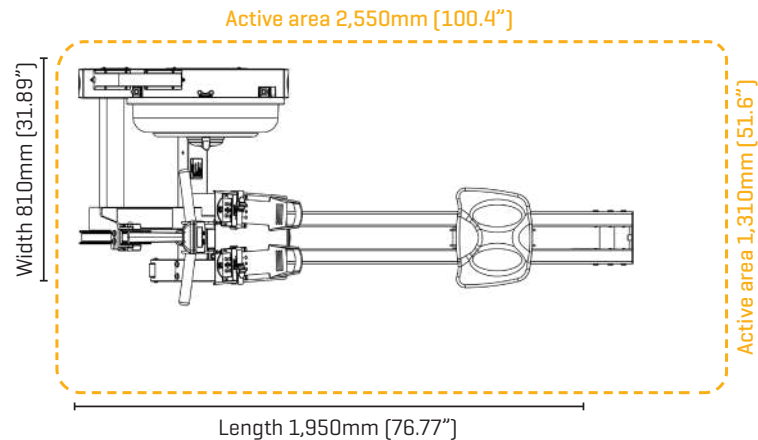

CONSOLE FEATURES

- + Bluetooth Connectivity
- + Auto start
- + Time - Elapsed time
- + Level - Auto to selected resistance level
- + 500M Time - Time to row 500 meters
- + Watt - Unit of power per stroke
- + Distance - Updated every second
- + SPM - Strokes per minute
- + Power Graphs - 2 Options
- + Heart rate - Polar compatible
- + Calories burned per hour



ABOUT FDF (FIRST DEGREE FITNESS)

FDF is the leader in designing and manufacturing a range of adjustable Fluid Resistance fitness machines for commercial and residential applications. At the heart of the fitness range is our unique and patented Twin Tank Fluid Resistance system. The adjustable Fluid Resistance system challenged the conventional thinking of how water could work to provide adjustable resistance rather than just a liquid mass flywheel. The patented Twin Tank system provides silky smooth resistance at any speed and is perfect for cardio training, warm-ups, cool downs, intense HIIT workouts or rehabilitation programs. FDF categorizes the range of adjustable Fluid Resistance machines under the banners, **FluidRower**, **FluidExercise** and **FluidPowerZone**, see the adjacent web links. FDF products are distributed throughout the globe and are popular in Fitness Centers, Hotels and Apartments, Sporting Clubs, Universities, First Responders, Defence Force Training Facilities and Physical Rehabilitation Clinics.

OPTIONAL FLUIDROWER ACCESSORIES



TOUCH HEART RATE HANDLE



SMARTPHONE HOLDER



SEAT BACK KIT



View all product ranges at

FLUIDPOWERZONE.com

FLUIDROWER.com

FLUIDEXERCISE.com