

obode

A8

ROBOT VACUUM CLEANER

# INSTRUCTION MANUAL



Please read the manual before use

# CONTENTS

---

<b>SAFETY INSTRUCTIONS</b>	<b>01</b>	<b>GETTING STARTED</b>	<b>14</b>
		Starting	14
		Pausing	14
		Resuming	14
		Shut Down	14
		Zone Cleaning	14
		Recharge	15
		Robot Vacuum Buttons	16
		Status Indicators of Robot Vacuum	16
		APP Usage	17
<b>TECHNICAL DATA</b>	<b>06</b>		
<b>IN THE BOX</b>	<b>07</b>		
Component Layout in Package	07		
Accessories Introduction	08		
Introduction to Parts of Robot Vacuum	09		
<b>PREPARATIONS BEFORE USE</b>	<b>10</b>	<b>MAINTENANCE AND COMMON PROBLEMS</b>	<b>18</b>
Installation of Charging Base	10	Maintenance of Dust Bin/Water Tank	18
Installation of Side Brush to Robot Vacuum	10	Maintenance of Main Brush	19
Power On & Recharge	11	Cleaning of Side Brush	20
Environmental Requirements	11	Cleaning of Driving Wheel	20
Preparations of the Water Tank	12	Mop Assembly Cleaning	21
Wi-Fi Pairing	12	Cleaning of Sensor and Spring Sheet	22
		Common Problems	23

---

# SAFETY INSTRUCTIONS

---

## ***Warning for the machine***

1. This appliance can be used by children aged from 8 years and above and persons with reduced physical, sensory or mental capabilities or lack of experience and knowledge if they have been given supervision or instruction concerning use of the appliance in a safe way and understand the hazards involved.  
Children shall not play with the appliance.  
Cleaning and user maintenance shall not be made by children without supervision.
2. Plug must be removed from the socket-outlet before cleaning or maintaining the appliance. Switch off before cleaning or maintaining the appliance.
3. If the supply cord is damaged, it must be replaced by the manufacturer, its service agent or similarly qualified persons in order to avoid a hazard.
4. **WARNING:** For the purposes of recharging the battery, only use the detachable supply unit provided with this appliance.  
Use only with DC2113 supply unit.
5. This appliance contains batteries that are only replaceable by skilled persons.
6. Do not bring the smart robot close to heat source, radiation or burning cigarette butts. It is strictly forbidden to vacuum the following objects:
  - 1) All liquids such as water and solvents;
  - 2) Lime, cement dust and other construction dust and garbage;
  - 3) Heat generating objects, such as unextinguished carbon butts, cigarette butts;
  - 4) Sharp fragments, such as glass, etc.;
  - 5) Flammable and explosive items, such as gasoline and alcohol products.
7. Before using, please remove all fragile items from the ground (such as glasses, lamps, etc.), and items that may be tangled with the side brush, Roller brush and drive wheels (such as wires, curtains and other easily-entangled materials).
8. Please pay attention to your hair and avoid entanglement on wheels or roller brushes when using, cleaning and maintaining the robot.
9. Do not use this product at an altitude of more than 2000m.

---

# SAFETY INSTRUCTIONS

---

## 10. Correct Disposal of this product.

This marking indicates that this product should not be disposed of with other household wastes throughout the EU. To prevent possible harm to the environment or human health from uncontrolled waste disposal, recycle it responsibly to promote the sustainable reuse of material resources. To return your used device, please use the return and collection systems or contact the retailer where the product was purchased. They can take this product for environmentally safe recycling.



## 11. Warranty Information

The manufacturer provides warranty in accordance with the legislation of the customer's own country of residence, with a minimum of 1 year (Germany: 2 years), starting from the date on which the appliance is sold to the end user. The warranty only covers defects in material or workmanship.

The repairs under warranty may only be carried out by an authorized service centre. When making a claim under warranty, the original bill of purchase (with purchase date) must be submitted. The warranty will not apply in cases of:

- Normal wear and tear
- Incorrect use, e.g. overloading of the appliance, use of non-approved accessories
- Use of force, damage caused by external influences
- Damage caused by non-observance of the user manual, e.g. connection to an unsuitable mains supply or non-compliance with the installation instructions
- Partially or completely dismantled appliances

## 12. WIFI:2400-2483.5MHZ, MAX POWRE:20dBm.

BLUETOOTH MAX POWR:10dBm

To satisfy RF exposure requirements, a separation distance of 20 cm or more should be maintained between the antenna of this device and persons during device operation. To ensure compliance, operations at closer than this distance is not recommended.

## 13. CLASS 1 LASER PRODUCT

INVISIBLE LASER RADIATION

(Note: Laser classified to Class 1 according to IEC 60825-1:2014)

---

# SAFETY INSTRUCTIONS

---

## ***Warning for docking station***

1. "IMPORTANT SAFETY INSTRUCTIONS - SAVE THESE INSTRUCTIONS" and "DANGER - TO REDUCE THE RISK OF FIRE OR ELECTRIC SHOCK, CAREFULLY FOLLOW THESE INSTRUCTIONS".
2. This appliance can be used by children aged from 8 years and above and persons with reduced physical, sensory or mental capabilities or lack of experience and knowledge if they have been given supervision or instruction concerning use of the appliance in a safe way and understand the hazards involved.  
Children shall not play with the appliance.  
Cleaning and user maintenance shall not be made by children without supervision.
3. Plug must be removed from the socket-outlet before cleaning or maintaining the appliance.  
Switch off before cleaning or maintaining the appliance.
4. If the supply cord is damaged, it must be replaced by the manufacturer, its service agent or similarly qualified persons in order to avoid a hazard.
5. Docking base is only applicable to the product A8. (Battery pack type : Li-ion, DC 14.4 V, 5200 mAh)  
The Docking base will automatically start charging after Robot Vacuum Cleaner returned to the base.
6. Warning: The battery charger(Docking station) is not intended to charge non-rechargeable batteries.

---

# SAFETY INSTRUCTIONS

---







## ***Warning for battery***

1. The product must be powered off before removing the battery.
2. Please note that do not disassemble the battery by yourself.
3. If you need to replace it, please contact the after-sales service center.
4. Please dispose of used battery according to local laws and regulations
5. Do not dismantle, open or shred the battery.
6. Do not expose batteries to heat or fire. Avoid storage in direct sunlight.
7. Do not short-circuit a battery.
8. Do not store batteries haphazardly in a box or drawer where they may short-circuit each other or be short-circuited by other metal objects.
9. Do not subject batteries to mechanical shock.
10. In the event of a leaking, do not allow the liquid to come in contact with the skin or eyes. If contact has been made, wash the affected area with copious amounts of water and seek medical advice.
11. Do not use any charger other than that specifically provided for use with the equipment.
12. Do not use any battery which is not designed for use with the equipment.
13. Do not mix different manufacture, capacity, size or type within a device.
14. Keep batteries out of the reach of children.
15. Seek medical advice immediately if the battery has been swallowed.
16. Keep batteries clean and dry.
17. Do not leave a battery on prolonged charge when not in use.
18. After extended periods of storage, it may be necessary to charge and discharge the batteries several times to obtain maximum performance.
19. The batteries give their best performance when they are operated at normal room temperature ( $20\text{ }^{\circ}\text{C} \pm 5\text{ }^{\circ}\text{C}$ )
20. Retain the original product literature for future reference.
21. The battery may be irreversibly damaged if the battery is in low power for a long time. It is recommended that the battery retain sufficient power before storage.

---

# SAFETY INSTRUCTIONS

---

	[symbol IEC 60417-5957 ( 2004-12 )]	for indoor use only
	[symbol ISO 7000-0790 ( 2004-01 )]	read operator's manual
	[symbol IEC 60417-5031 ( 2002-10 )]	direct current
	time-lag miniature fuse-link where X is the symbol for the time/current characteristic as given in IEC 60127	
	[symbol IEC 60417-5032 ( 2002-10 )]	alternating current
	[symbol IEC 60417-5172 ( 2003-02 )]	class II equipment

---

# TECHNICAL DATA

---

1. Product Model: A8
2. Host Charging Voltage: 16.7V  $\approx$
3. Host Rated Voltage: 14.4V  $\approx$
4. Host Rated Power: 55W
5. Docking Station Model: DC2113
6. Docking Station Input: 100-240V~,50-60Hz,24W
7. Docking Station Output: 16.7V $\approx$  , 1A
8. Battery Model: BP14452C
9. Battery Rated Voltage: 14.4V  $\approx$
10. Battery Capacity: 5200mAh 74.88Wh
11. Charging Limit Voltage: 16.8V  $\approx$

Midea Robozone Technology Co.,Ltd  
Add.: No.39 Caohu Avenue, Xiangcheng Economic  
Development Zone,Suzhou, Jiangsu, China  
Company: KD EUROPE  
Address: Stara Debszczyczna 4, 16-424, Filipow, Poland  
Mail: Kdeurope.office@gmail.com

Note: You can also view the instructions on the app.



# IN THE BOX

## Component Layout in Package

Layout of Upper Layer

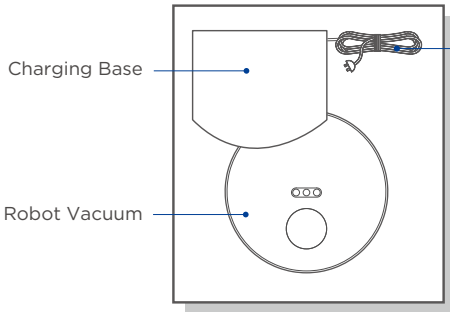

Layout of Lower Layer

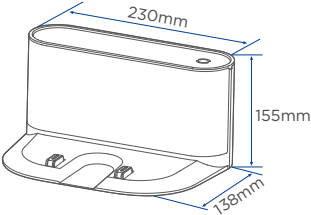
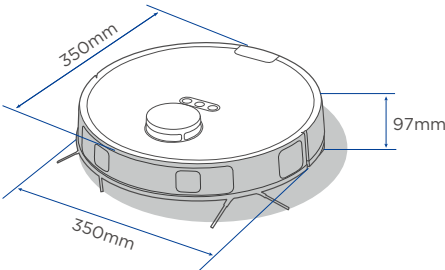
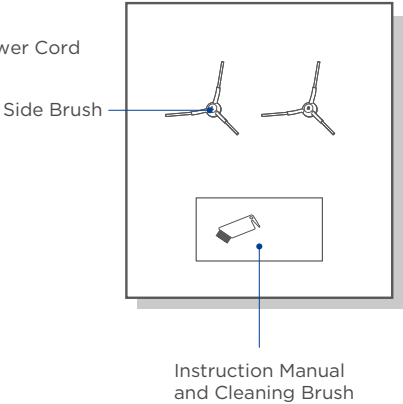

---

# IN THE BOX

---

## Accessories Introduction

Side Brush x4

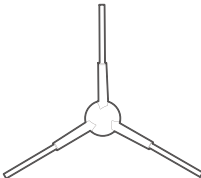

Filter Mesh

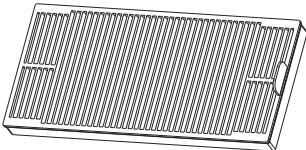

Instruction Manual

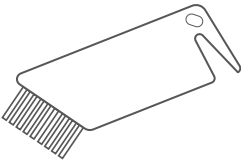

Instruction Manual



Mopping Cloth



# IN THE BOX

## Introduction to Parts of Robot Vacuum

### Main View

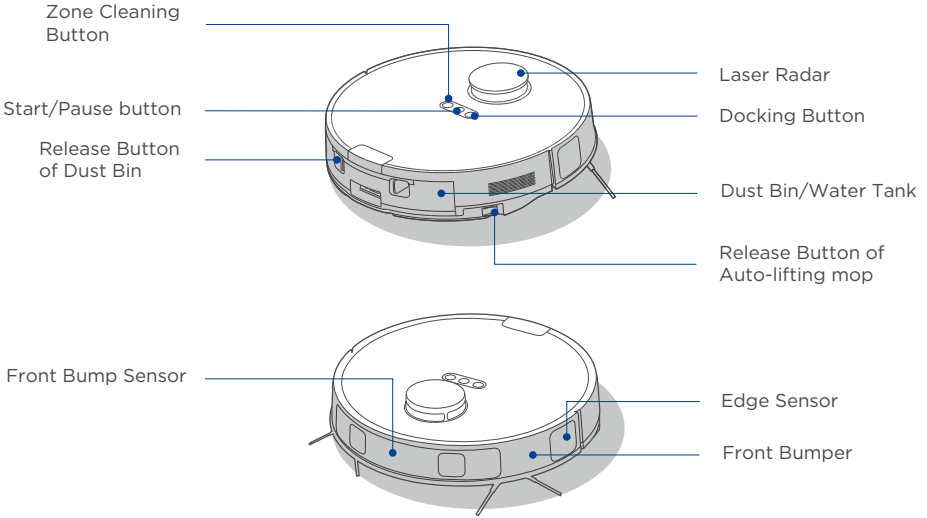

### Bottom View

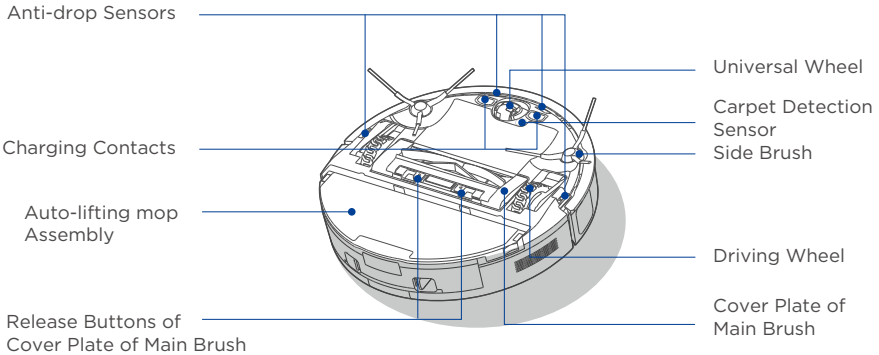

# PREPARATIONS BEFORE USE

## Installation of Charging Base

- 1 Make sure that there is more than 0.5m on both sides of the charging base, and an open area of more than 1.5m in front.
- 2 Store the excess cord into the slot of back of the charging base to avoid affecting the work of the robot vacuum.

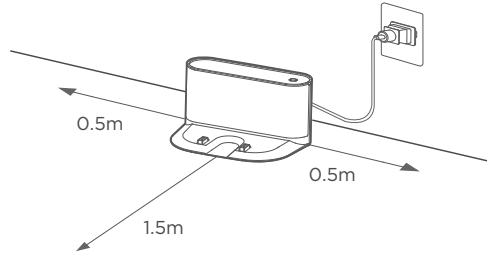

## Notes

1. Avoid direct sunlight.



2. Do not cover the signal transmission area of charging base with stickers or other objects.



3. Avoid placing the base on carpet and soft floor.

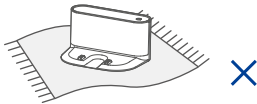

4. Be sure to keep the charging area dry.

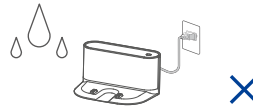

## Installation of Side Brush to Robot Vacuum

- 1 Ensure that the color of the side brush installed is the same as that of the slot on the bottom of robot vacuum, and then press the side brush directly into the corresponding slot. When you hear a "click", the installation is complete.
- 2 To remove the side brush, please place the robot vacuum upside down, grab the rubber-coated legs of the side brush with both hands (be careful not to pull the hair bundle vigorously) and pull it out.

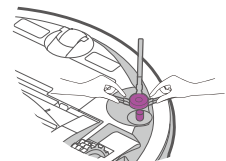
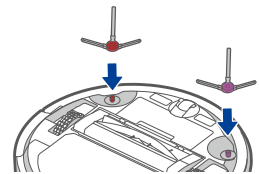

---

# PREPARATIONS BEFORE USE

---

## Power on & Recharge

Press and hold "⏻" for 3 seconds to power on the robot vacuum. After the power indicator turns on, put the robot vacuum into the charging base for charging, as shown. To ensure that the robot vacuum is always ready for use, keep it in the charging state.

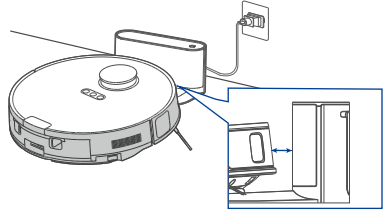

## Notes

1. If you manually put the robot vacuum into the base, ensure that the side with the charging contacts is placed inside and the charging contacts of both robot and base are connected, at this moment, there is a certain distance between the robot's front bumper and base.
2. Ensure that the robot vacuum is fully charged before first use.
3. When the robot vacuum is successfully docked, the power indicator on the robot flashes, and a beeping sound is emitted at the same time, indicating that it is in the charging state at this moment.

## Tips

After the robot vacuum is manually put into the base, the robot vacuum will automatically power on.

## Environmental Requirements

Before using the robot vacuum, please make sure the area to be cleaned is free from items that may be tangled/stuck with the robot vacuum (such as wires, hard objects, iron nails, glasses and other sharp fragments), and items that may be dragged or knocked down by the robot vacuum (such as valuable objects, fragile objects and dangerous objects likely to fall). This helps ensure that the robot vacuum does not cause personal injury or property damage.

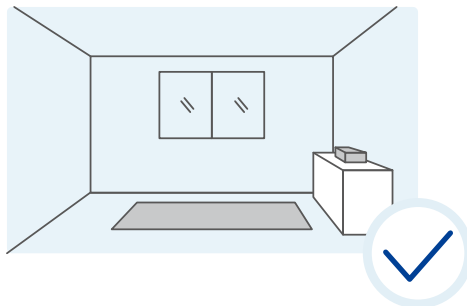

---

# PREPARATIONS BEFORE USE

---

## Preparations of the Water Tank

When using floor mopping function, fill the water into the water tank.

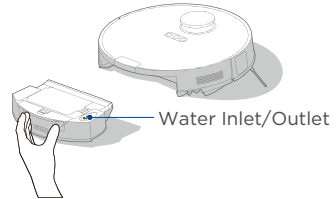

## Wi-Fi Pairing

- 1 Ensure the mobile phone is connected to your home Wi-Fi.



- 2 Download the obodo Life and register your vacuum. Scan the QR code or search for the app in the Apple or Google Play Store to download the app. Open the app and create your personal account. Follow instructions on the screen.



- 3 Add your robot vacuum to your app. Press the "+" button on the main screen of the app and select A8 from the available list of products.



- 4 Connect your robot to your Wi-Fi. After assembling and powering on the robot, press and hold down the "Wi-Fi" button for 3 seconds until a beep sound is heard. The Wi-Fi indicator light should start to flicker. Follow instructions on app for next steps.

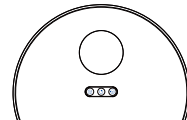

---

# PREPARATIONS BEFORE USE

---

## Notes

---

If your home Wi-Fi name or password is changed, you will need to re-establish connection with your robot vacuum.

1. App supports iOS 10.0 and above, Android 6.0 and above phone system versions, but pad device is not accepted; Generally the phone system version can be checked through the "Settings>About Phone" on the phone.

2. This model does not support WEP encrypted router.

3. The network accessing configuration of the cleaner requires Wi-Fi network of 2.4GHz frequency range, 5GHz frequency range is currently incompatible.

4. Do not configure network accessing under the charging state.

5. Wi-Fi is mandatory for network accessing configuration of the cleaner; once the network accessing is configured successfully, the App may be operated in Wi-Fi/2G/3G/4G network environment and the cleaner may be controlled remotely.

6. If your home's Wi-Fi password or router is changed, the robot vacuum cleaner will be displayed as offline on the App: Without changing the App account, you only need to re-configure the network once again.

7. If others want to use the App to operate the same cleaner, they will need to be invited on App by the family creator to join in (in the condition that the invitee has downloaded App and has registered an account).

8. When the App changes, the old users may be asked to remove their device in the mobile App and the new users will just need to configure directly their network by accessing in accordance with network access instructions (if the old users don't remove their device on the mobile App, it will be removed automatically after the new users successfully configured network access).

9. Once the cleaner successfully configured network access, the following operations will result in clearance of Wi-Fi settings and secondary network accessing configuration is required; Long press the network accessing configuration key on the device for over 3 seconds, and after a ticking sound is heard, all Wi-Fi information will be cleared.

---

# GETTING STARTED

---

## Starting

Press "⏻" to start cleaning the whole house.

## Pausing

Press "⏻" to pause during cleaning.

## Resuming

Press "⏻" on the robot vacuum briefly to resume cleaning.

## Shut Down

Press and hold "⏻" for a while to shut down.

## Zone Cleaning

When the robot vacuum is in standby mode, press "🔄" to start zone cleaning.

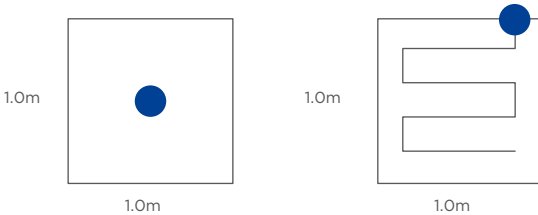



---

# GETTING STARTED



---

## Recharge

Press "" briefly and the robot vacuum will return to the charging base and start recharging.



## Notes

---









1. When the robot vacuum reports a fault, the power light will flash quickly. Please press "" or "" briefly to clear the fault.
2. When the battery is too low, the cleaning process cannot be started. Please charge before operating.
3. During the cleaning process, if the battery is too low, the robot vacuum will automatically recharge, and after fully charged, it will return to the place where the cleaning is interrupted to continue the process.
4. When the robot vacuum is charging, the power indicator will flash slowly; when the charging is completed, the power indicator will stay on.
5. The robot vacuum will enter sleep mode when it is in standby mode for more than 10 minutes. In sleep mode, press any key to wake up the robot vacuum.
6. The robot vacuum cannot be shut down when it is on the recharge base. Please remove the robot vacuum from the charging base before shutting down.
7. This product is intended for indoor use only. Do not use it outdoors.
8. Do not submerge the robot vacuum in water. Doing so may damage the equipment, causing a short circuit or current leakage.

# GETTING STARTED

## Robot Vacuum Buttons

Operation	Button		
			
Press for 1s	Start/resume/pause	Return to the base	Start zone cleaning
Press and hold for 3s	Shut down	/	Enter the Wi-Fi pairing state

## Status Indicators of Robot Vacuum

Indicator Light	Status	Actions
 The standby light stays on	Standby/Cleaning/Cleaning process has been completed and recharging is in progress.	/
 The standby light is off	The robot vacuum has been shut down or in sleep mode.	/
 The standby light flashes quickly	The robot has failed.	Refer to "Common Problems"
 The standby light flashes slowly	The robot is charging.	/
 The recharging red light stays on	The battery is not low and recharging is in progress.	/
 The recharge red light flashes	The battery is low and recharging is in progress.	/
 The Wi-Fi light stays on	The robot is in zone cleaning process.	/
 The Wi-Fi light flashes quickly	The robot vacuum is connecting to the network.	/
 The Wi-Fi light flashes slowly	The robot vacuum is waiting to be configured with a network.	/

# GETTING STARTED

## Notes

If the Wi-Fi in your home is unstable, it may cause a certain delay in the related operations of the App (The content of the App is subject to the upgraded version of the App. Please refer to the robot interface for details).

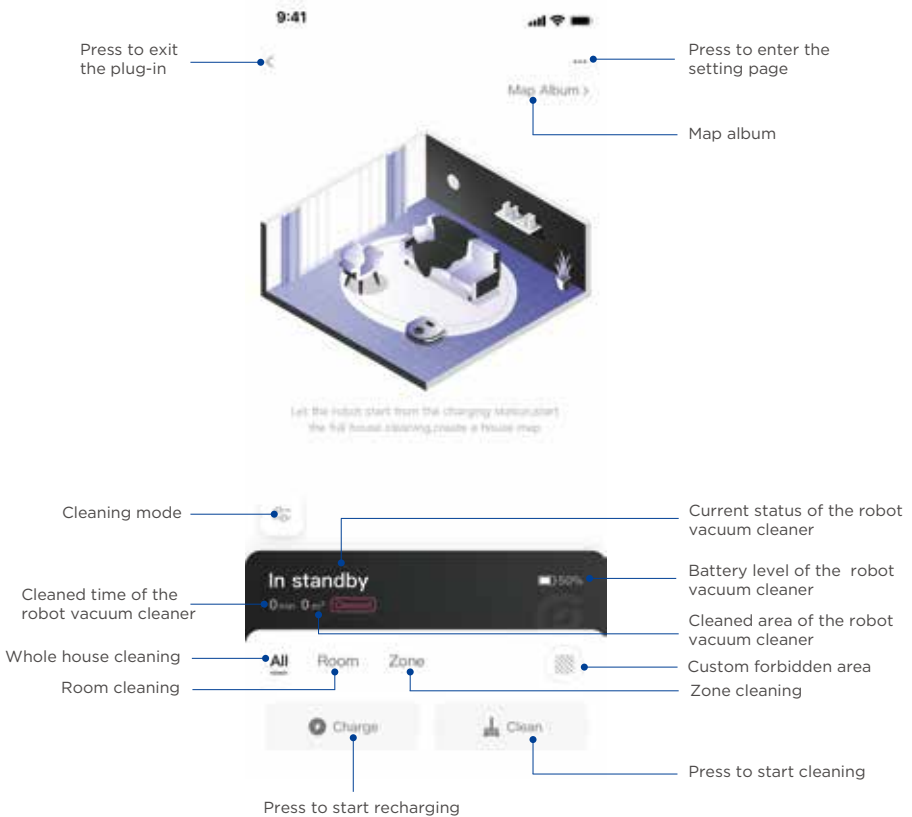

Note: The interface is only for reference, and will be updated continuously.

---

# MAINTENANCE AND COMMON PROBLEMS

---

## Maintenance of Dust Bin/Water Tank (Clean as needed)

- 1 Take out the dust bin.  
Press and hold the release button of the dust bin with two fingers and take out the dust bin backwards.

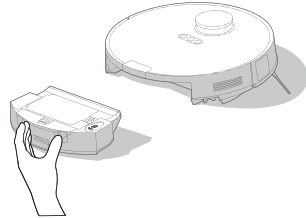

- 2 Open the lid of the dust bin and take out the filter assembly.

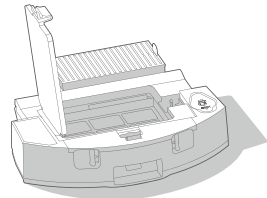

- 3 Clean the dust bin, filter assembly and filter cotton. After cleaning and fully drying, install all accessories back in place, close the back cover and check whether the installation is perfect (both dust bin and filter assembly can be washed with water).

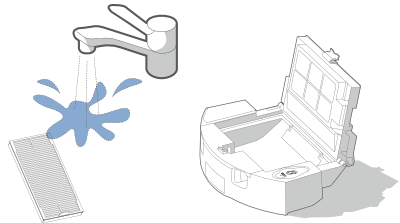

### Tips

To ensure optimal filtering, it is recommended to clean and replace the filter mesh regularly.

- 4 When cleaning the dust bin, open the rubber cover to pour out the rest water in the water tank. After cleaning, make sure the rubber cover is closed and place the water tank back into place.

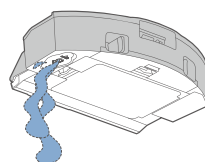

---

# MAINTENANCE AND COMMON PROBLEMS

---

How to use the cleaning brush:

- ① Cut the hair entangled on the main brush body with the blade.
- ② Brush off the cut hair with the brush.

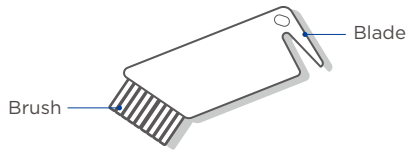

## Maintenance of Main Brush (weekly cleaning is recommended)

- 1 Place the robot vacuum upside down, put your hand on the notch on the upper part of the cover plate of the main brush, press down to release the cover plate of the main brush and pull it out, and lift the right side of the main brush to take it out.

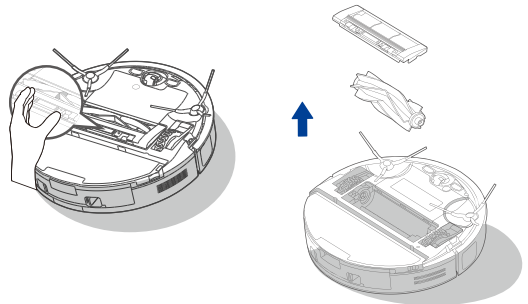

- 2 Clean the main brush and its cover plate with the cleaning brush or a soft cloth.

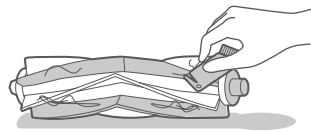

- 3 Wash the main brush with water and dry it.

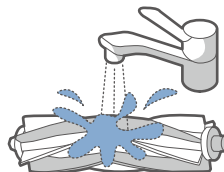

---

# MAINTENANCE AND COMMON PROBLEMS

---

- 4 After cleaning, press the end cover back to the main brush body. Install the main brush body into the main brush cavity according to the direction shown in the figure.

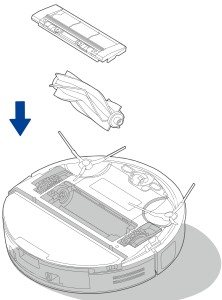

## Cleaning of Side Brush (Weekly cleaning is recommended)

- 1 Pull out the side brush.

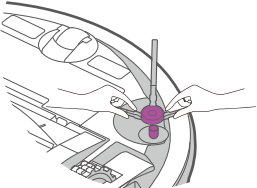

- 2 Remove dust on the side brush.

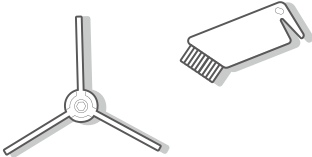

## Cleaning of Driving Wheel (weekly cleaning is recommended)

Rotate the driving wheel back and forth to remove foreign matters - remove and take out the hair or foreign matters with the cleaning tool or a soft cloth.

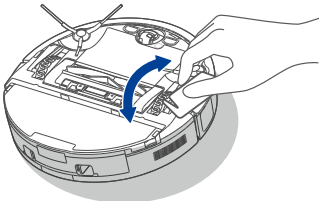

---

# MAINTENANCE AND COMMON PROBLEMS

---

## Mop Assembly Cleaning

1 Release the mop assembly and clean it.

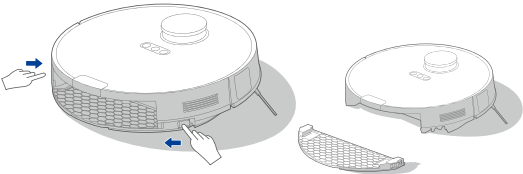

2 Remove the mopping cloth from the mop holder.

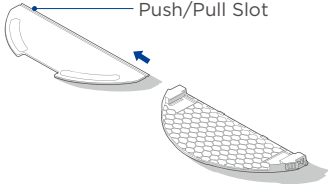

3 Wash the mopping cloth with water and dry it; then place the cleaned mopping cloth back to the mop holder and re-install the mop assembly to the robot vacuum.

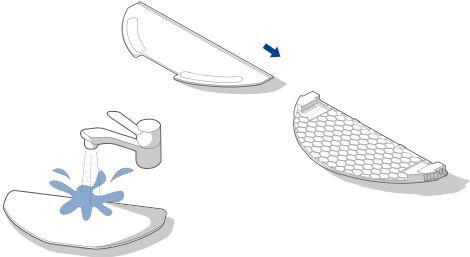

---

# MAINTENANCE AND COMMON PROBLEMS

---

## Cleaning of Sensor and Spring Sheet (Weekly cleaning is recommended)

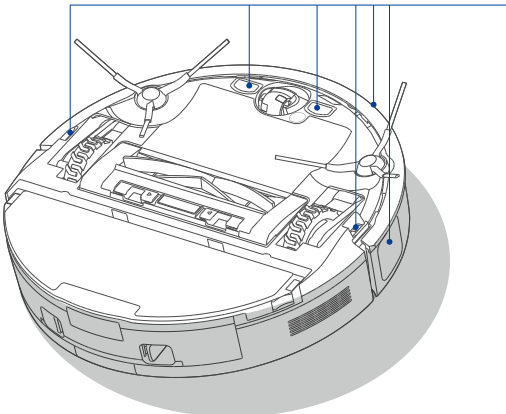

Gently wipe the sensor with a dry soft cloth to remove the dust on the surface.

Gently wipe the charging contacts with a dry soft cloth to ensure normal charging.

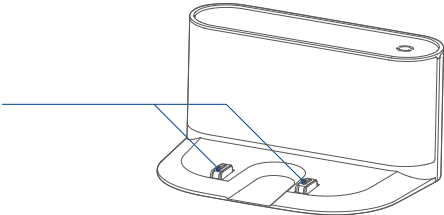



# MAINTENANCE AND COMMON PROBLEMS

## Common Problems

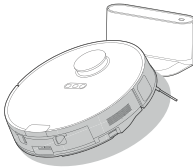
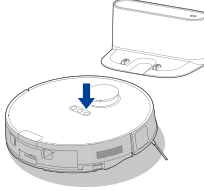
Faults
The robot vacuum cannot be recharged
Possible Causes
The robot vacuum is not in contact with the charging contacts.

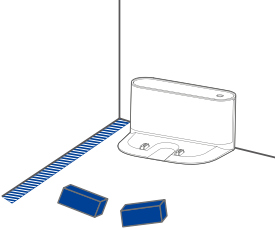
Actions
Place the robot vacuum 1m in front of the charging base and press the docking button.

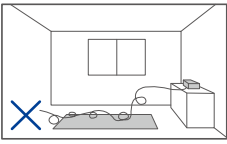
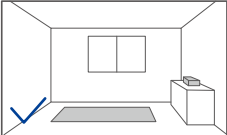
Faults
The robot vacuum cannot return for charging
Possible Causes
The charging base is placed improperly.

Actions
Refer to page 11 of the Manual

Faults
The robot vacuum is trapped - 1
Possible Causes
The robot vacuum is entangled/stuck by objects (such as cords) on the floor.

Actions
Please put away the scattered cords and objects on the floor.

# MAINTENANCE AND COMMON PROBLEMS

**Faults**

The robot vacuum is trapped - 2

**Possible Causes**

The side brush/main brush is stuck so that the robot vacuum cannot move normally.

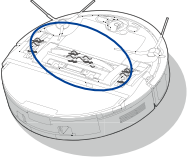

**Actions**

Remove the objects that caused the main/side brush to be stuck and place the robot vacuum flat on the floor and start the robot vacuum.

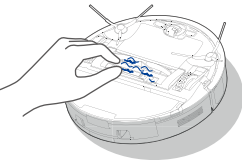

**Faults**

The robot vacuum is trapped- 3

**Possible Causes**

The robot vacuum is stuck by obstacles.

**Actions**

Remove the obstacles and proceed with cleaning, or set restricted zones in App.



**Faults**

Cleaning process has not been completed, but the robot vacuum returns for charging

**Possible Causes**

The robot vacuum has detected low power.

**Actions**

Let the robot vacuum return for charging.

# MAINTENANCE AND COMMON PROBLEMS

Faults
Fail to clean on appointment - 1
Possible Causes
Scheduled appointment has been cancelled.
Actions
Reset appointment.

Faults
Fail to clean as appointment - 2
Possible Causes
The robot vacuum is in "Do Not Disturb Mode".
Actions
Turn off "Do Not Disturb Mode" or adjust the "do not disturb time interval".

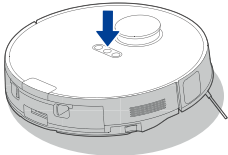
Faults
The robot vacuum does not work
Possible Causes
Left/right wheel is suspended.

Actions
Place the robot vacuum flat on the floor and start the robot vacuum.

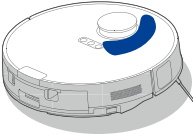
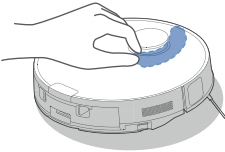
# MAINTENANCE AND COMMON PROBLEMS

<b>Faults</b>
The robot vacuum moves backward - 1
<b>Possible Causes</b>
The protective cover of navigation module is stuck.

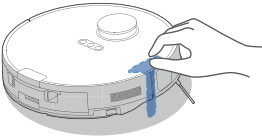
<b>Actions</b>
Gently tap the protective cover to remove foreign matter.

<b>Faults</b>
The robot vacuum moves backward - 2
<b>Possible Causes</b>
There is obstacle ahead.
<b>Actions</b>
Remove the obstacle ahead.

<b>Faults</b>
The robot vacuum moves backward - 3
<b>Possible Causes</b>
The front bumper is stuck.

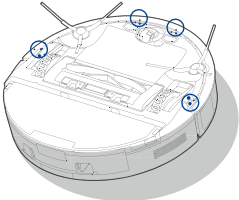
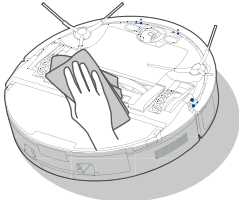
<b>Actions</b>
Gently tap the front bumper to remove foreign matters.

# MAINTENANCE AND COMMON PROBLEMS

Faults
<p>The robot vacuum moves backward - 4</p>
Possible Causes
<p>There is dust accumulated on the anti-drop sensors.</p>

Actions
<p>Clean the dust accumulated on the surface of anti-drop sensor.</p>

Faults
<p>The robot vacuum has no sound</p>
Possible Causes
<ul style="list-style-type: none"><li>· The sound is set to mute or low volume.</li><li>· The robot vacuum is in "Do Not Disturb Mode".</li></ul>
Actions
<ul style="list-style-type: none"><li>· Turn up the volume.</li><li>· Turn off "Do Not Disturb Mode"</li></ul>

Faults
<p>The App shows the connection is disconnected</p>
Possible Causes
<ul style="list-style-type: none"><li>· The phone is not connected to the network normally.</li><li>· The router is not working normally.</li><li>· The robot vacuum is not turned on.</li><li>· Wi-Fi configuration of the device is cleared.</li><li>· Wi-Fi password or network has been changed.</li></ul>
Actions
<ul style="list-style-type: none"><li>· Reconnect the phone network.</li><li>· Restart the router.</li><li>· Turn on the power switch of robot vacuum.</li><li>· Add new appliances in the App.</li><li>· After the system is started, press the network configuration key and hold for 3 seconds. Release it when you hear the beep.</li><li>· Add the device again as the phone's instructions.</li></ul>

---

# MAINTENANCE AND COMMON PROBLEMS

---

Faults
App operation response delays
Possible Causes
<ul style="list-style-type: none"><li>· The network is busy.</li><li>· Wi-Fi signal reception of the phone is poor.</li><li>· The network bandwidth is insufficient.</li></ul>
Actions
<ul style="list-style-type: none"><li>· Restart the router to reduce the number of access users.</li><li>· Check the phone settings.</li><li>· Increase the network bandwidth.</li></ul>

- Please see the App push information for more exception handling.





ROBOT VACUUM CLEANER