

SDM320Y

SINGLE PHASE PREPAID MULTI-FUNCTION ENERGY METER

- Direct connection up to 100A
- Built-in relay, to stop power supply due to arrears
- Support overdraft basing on credit line
- Support prepaid setting
- Support load control
- Support abnormal power consumption monitoring
- Support lo-lo power alarm
- Support Multi-measurement
- S0 output for energy pulse emission
- Rs485 Modbus communication
- Support historical daily/ monthly energy statistic, daily data query
- Class 0.5S
- LCD display with 8 main digits



Introduction

SDM320Y prepaid energy meter is our latest model of single phase electronic prepaid energy meter. It is in full compliance with technical requirements of IEC62053-22 standard for Class 0.5S energy meter. It has a complete prepaid management system, which is convenient for power purchase. The system automatically deducts fees according to electricity consumption. Recharging operation can be done through network remotely, no need any medium such as IC card. The meter has two-level balance alarm function and an emergency amount function. It will automatically stop power supply when tenant in arrears or credit become zero or reaching the pre-set value and the real-time monitoring the look whether there is any abnormal situation.

The meter is with excellent reliability that can display remaining capacity, available remaining, total power consumption/ purchase of electricity, credit line, overdraft consumption, load threshold, pay model, voltage, current, active power, active energy, import energy, export energy, power factor, frequency and time ect. The reactive power, apparent power can be read by Modbus.

SDM320Y is easy to install with nice appearance, small and light. With battery installed inside the meter, the value on the meter still can be read when grid power off.

SDM320Y is suitable for real-time power monitoring system and has the characteristics of multi-function, multi-purpose, high stability and long life.

The meter has 1 pulse output, and the pulse constant, pulse width and output unit all can be set.

It has RS485 communication interface, support high speed communication function of RS485 (9600bps). It is an ideal choice for power energy monitoring.

Multi-measurement

- Current-instantaneous : I
- Voltage & Frequency-instantaneous : V, F
- Power-instantaneous : P
- Power Factor-instantaneous : PF
- Active energy : kWh
- Reactive energy : kVarh

Conformity to Standards

- Active energy Class 0.5s according to IEC 62053-22
- Active energy Class 1.0 according to IEC 62053-21
- Reactive energy Class 2.0 according to IEC 62053-23

Applications

- Measurement of energy generated by renewable source such as solar, eolic etc.
- Accounting and billing of consumptions in camp in camp sites, mails, residential areas, naval ports, etc.
- Realization of energy monitoring systems.
- Remote survey of the consumptions and compute of the costs.
- Accounting of the consumption in buildings with executive office services.
- Internal allocation of the consumption in timeshare civilian and industrial buildings.
- Totalization of the electric consumption in hotel, congress centers, exhibition fairs.

Specification	
Nominal voltage(Un)	230V ac
Operational voltage	80%~120% of Un
Insulation capabilities	
- AC voltage withstand	4KV for 1 minute
- Impulse voltage withstand	6KV-1.2μS
Basic current (Ib)	10A
Operational current range	0.4% Ib - I _{max}
Over current withstand	30 I _{max} for 0.01s
Operational frequency range	50 or 60Hz
Power consumption per phase	≤ 2W/10VA
Display	LCD
Max reading	999999.99 kWh/kVarh

Performance criteria	
Operating humidity	≤ 90%
Storage humidity	≤ 95%
Operating temperature	-25°C - +55°C
Storage temperature	-40°C - +70°C
Reference temperature	23°C ± 2°C
International standard	IEC 62053-22
Accuracy class	Class 0.5S
Installation category	CAT II
Mechanical environment	M1
Electromagnetic environment	E2
Degree of pollution	2
Protection against penetration of dust and water	IP51 (indoor)
Insulating encased meter of protective class	II
Electrostatic discharges	8kV contact / 15kV air gap
Electromagnetic HF fields	IEC 61000-4-3
Electrical fast transients	4kV

Accuracy	
Voltage, Current	0.2%
Frequency	0.2% of mid-frequency
Power factor	1% of unity (0.01)
Active power , Apparent power	±0.5% of range maximum
Reactive power	±1% of range maximum
Reactive energy (Varh)	Class 2
Active energy (Wh)	Class 0.5s / Class 1.0

Modbus	
Bus type	RS485(semi-duplex)
Protocol	Modbus RTU
Baud rate	1200/2400/4800/9600bps
Address range	1-247
Max. Bus loading	64pcs
Communication distance	1000M
Parity	EVEN/ODD/NONE
Data bit	8
Stop bit	1

Communication	
Terminal wire area	0.5-1mm ²
Recommended tightening torque	0.25Nm

Pulse Output	
Pulse outputs	1
Pulse output type	Passive
Pulse Output 1	Configurable
Pulse width	200/100(default)/60ms
Pulse output 2	1000imp/kWh

Wiring diagram

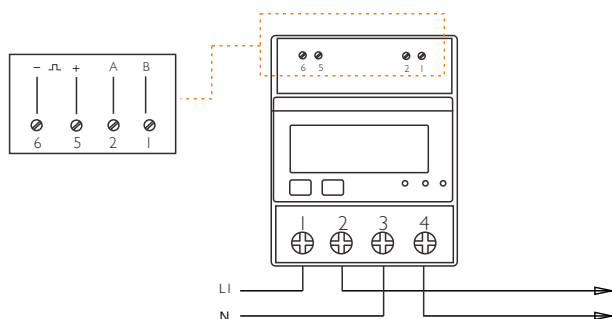

Dimensions

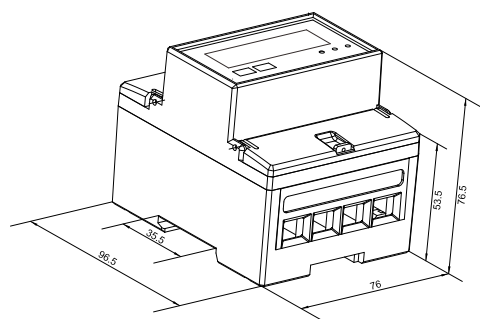

Height 76.0mm
Width 96.5mm
Depth 76.5mm