

SDM230 SERIES

Single Phase Two Wires Multifunction Din rail Meter



User Manual V1.5

Warnings

Important Safety Information is contained in the Maintenance section. Familiarize yourself with this information before attempting installation or other procedures.



Risk of Danger: These instructions contain important safety information. Read them before starting installation or servicing of the equipment.



Caution: Risk of Electric Shock

1. Introduction

This document provides operating, maintenance and installation instructions of SDM230 series made by Eastron Electronic Instruments Co., Ltd. The SDM230 series measure and display the characteristics of single phase two wires (1p2w) network. The SDM230 series cover 3 models: SDM230-Modbus, SDM230-Mbus, SDM230-2T.

The bi-directional measurements makes the meter suitable for active and reactive energy and power monitoring applications, and also perfect for solar PV measurements. With RS485 Modbus and M-bus port, the meter is easy to remote communication with other AMR/SCADA systems.

Model	Measurements	Communication	Pulse Outputs	Multi Tariffs
SDM230-Modbus	U, I, P, Q, S, PF, Hz, Dmd, kWh, kVarh, Import, Export	RS485 Modbus	1: configurable 2: 1000imp/kwh	NO
SDM230-Mbus	U, I, P, Q, S, PF, Hz, Dmd, kWh, kVarh, Import, Export	M-bus EN13757-3	1: configurable 2: 1000imp/kwh	NO
SDM230-2T	U, I, P, Q, S, PF, Hz, Dmd, kWh, kVarh, Import, Export	RS485 Modbus	1: configurable 2: 1000imp/kwh	2 Tariffs (time relay)

1.1 Key Characteristics

- Bi-directional measure and display
- Multi-function measurements
- Two Pulse outputs
- RS485 Modbus / M-bus
- 100A direct connection
- Two module size (35mm)
- Password protected set-up
- Backlighted LCD

1.2 Pulse output

The meter provides two pulse outputs. Both pulse outputs are passive type.

Pulse output 1 can be set to generate pulses to represent total / import/export kWh or kVarh.

The pulse constant can be set to generate 1 pulse per: 0.001/0.01/0.1/1kWh/kVarh (default is 0.001 export kWh).

Pulse width: 200/100/60ms

Pulse output 2 is non-configurable. It is fixed up with active kwh (Imp). The constant is 1000imp/kWh.

1.3 RS485 Serial – Modbus RTU

RS485 serial port with Modbus RTU protocol to provide a means of remotely monitoring and controlling the Unit. Set-up screens are provided for setting up the RS485 port.

1.4 Mbus for SDM230-Mbus

This unit has an M-BUS serial port with M-BUS protocol to provide a means of remotely monitoring and controlling the Unit. Set-up screens are provided for setting up the M-bus port.

1.5 2T by time relay for SDM230-2T

The unit has a time relay inside which can monitor if there is external 230V signal input. If there is 230V signal input, the meter switches Tariff 2 measurement, otherwise it will measure as Tariff 1.

2. Operation

2.1 LCD Display

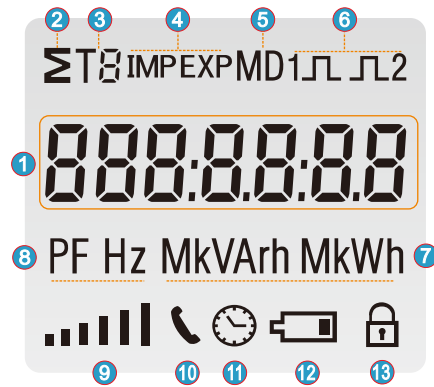

NO.	Descriptions
1	7 digits used to display measured values
2	Total value
3	Tariff information
4	Import information, Export information
5	Max. Demand for Power or Current.
6	Pulse output 1 and Pulse output 2
7	Measurement units
8	PF = power factor Hz = frequency
9	Bar display of Power
10	Communication indicator
13	Lock symbol

2.2 Initialization Display

	All display segments light up, display check.
	Software version (please check the real software version on the product as the final).
	Modbus ID or Mbus Primary Address
	Baud rate.
	Total kWh.

2.3 Scroll display by Buttons

After initialization and self-checking program, the meter display the measured values. The default page is total kWh. If the user wants to check other information, he needs to press the scroll button on the front panel.

The display order by scroll button:

*For SDM230-Modbus:

Total kWh → Import kWh → Export kWh → resettable kWh → total kVarh → Import kVarh → Export kVarh → resettable kVarh → Max. Power Demand → Voltage → Current → W → Var → VA → Power Factor → Frequency → Pulse Constant → Modbus ID → Baud Rate → continuous running time
Display No: 1, 4~7, 10~24.

*For SDM230-2T:

Total kWh → T1 total kWh → T2 total kWh → Import kWh → Export kWh → resettable kWh → Total kVarh → T1 total kVarh → T2 total kVarh → Import kVarh → Export kVarh → resettable kVarh → Max. Power Demand → Voltage → Current → W → Var → VA → Power Factor → Frequency → Pulse Constant → Continuous running time
Display No: 1~24.

*For SDM230-Mbus:

Total kWh → Import kWh → Export kWh → resettable kWh → Total kVarh → Import kVarh → Export kVarh → resettable kVarh → Max. Power Demand → Voltage → Current → W → Var → VA → Power Factor → Frequency → Pulse Constant → Mbus Primary Address → Mbus Secondary Address → Baud Rate → Continuous running time
Display No: 1, 4~7, 10~24.

1		Total active energy Example: 70.00kWh
2		T1 active energy Example: 10.00kWh (for SDM230-2T only)
3		T2 active energy Example: 10.00kWh (for SDM230-2T only)
4		Import(input) active energy Example: 50.00kWh
5		Export(output) active energy Example: 20.00kWh
6		Resettable total energy
7		Total reactive energy Example: 10.00kVarh
8		T1 reactive energy Example: 2.00kVarh (for SDM230-2T only)
9		T2 reactive energy Example: 2.00kVarh (for SDM230-2T only)
10		Import(input) reactive energy Example: 5.00kVarh
11		Export(output) reactive energy Example: 5.00kVarh
12		Resettable total energy
13		Max Power Demand Example: 6938W
14		Voltage Example: 229.8V
15		Current Example: 30.156A
16		Active Power Example: 4700W

17		Reactive Power Example: 1030Var
18		Apparent power Example: 4811VA
19		Power factor Example: 1.000
20		Frequency Example: 49.99Hz
21		Pulse 2 Constant Example: 1000
22		Modbus Address Example: 001 Mbus primary address Example: 001
22-1		High and Low bit of MBUS Secondary address (Default 00 00 00 01) Example: if the Secondary address high bit is 0000, low bit is 0001, that means the integral Secondary address is 00 00 00 01 (for SDM230-Mbus only)
23		Baud rate Example: 9600
24		Continuous running time (since last time reset)

2.4 Set-up Mode

To get into Set-up Mode, the user needs to press the "Enter" button for 3 seconds.

		The setting is done correctly
		The entering information is wrong. The operation fails.
1		Password To get into Set-up mode, it asks a password confirmation. Default password: 1000
2		Address For Modbus: Default ID is 001 Range: 001~247 For Mbus: Primary Address ID Default ID is 001 Range: 001~250
2-1		Press the "Enter" button, the first digit flash. Press the "Scroll" button to change the value. After choose the new address value, the user need pressing the "Enter" button to confirm the setting.

2-2		High bit of Mbus Secondary address(Default 00 00) (for SDM230-Mbus only)
		Low bit of Mbus Secondary address(Default 00 01) Example: if the Secondary address high bit is 0000, low bit is 0001, that means the integral Secondary address is 00 00 00 01 (for SDM230-Mbus only)
2-3		Press the "Enter" button, the red part flash. Press the "Scroll" button to change the option. After choose the new value, the user need pressing the "Enter" button to confirm the setting.
3		Baud rate for Modbus Default value: 2400bps Range: 1200, 2400, 4800, 9600bps. Baud rate for Mbus: Default value: 2400bps Range:300, 600, 1200, 2400, 4800, 9600bps.
3-1		Press the "Enter" button, the red digit flash. Press the "Scroll" button to change the value. After choose the new baud rate, the user need pressing the "Enter" button to confirm the setting.
4		Parity Default: None Option : None, Even, Odd
4-1		Press the "Enter" button, the red part flash. Press the "Scroll" button to change the option. After choose the new Parity, the user need pressing the "Enter" button to confirm the setting.
5		Pulse Output 1 Default: kWh Option:kWh / KVarh / Imp. kWh / Exp.kWh / Imp.kVarh / Exp.kVarh
5-1		Press the "Enter" button, the red part flash. Press the "Scroll" button to change the option. After choose the new Pulse output option, the user need pressing the "Enter" button to confirm the setting.
6		Pulse Constant Default: 1000 Option: 1000 / 100 / 10 / 1
6-1		Press the "Enter" button, the red part flash. Press the "Scroll" button to change the option. After choose the new Pulse constant option, the user need pressing the "Enter" button to confirm the setting.
7		Pulse duration Default: 100ms Option: 200 / 100 / 60ms
7-1		Press the "Enter" button, the red part flash. Press the "Scroll" button to change the option. After choose the new Pulse duration option, the user need pressing the "Enter" button to confirm the setting.
8		Demand Integration Time Default: 15 minutes Option: off(0) / 5 / 10 / 15 / 30 / 60
8-1		Press the "Enter" button, the red part flash. Press the "Scroll" button to change the option. After choose the new DIT option, the user need pressing the "Enter" button to confirm the setting.
9		Automatic Scroll Time Interval Default: 0 S Option: 0 ~ 30S

9-1		Press the "Enter" button, the red part flash. Press the "Scroll" button to change the option. After choose the new "Scrl" option, the user needs to press the "Enter" button to confirm the setting.
10		Backlit lasting time set-up Default: 60 min Option: 0(off) / 5 / 10 / 20 / 30 / 60 Long press "Enter" button to enter set-up mode.
10-1		Press the "Enter" button, the red part flash. Press the "Scroll" button to change the option. After choose the new "Scrl" option, the user needs to press the "Enter" button to confirm the setting.
11		Clear Long press "Enter" to enter clear interface.
11-1		Clear Max demand of active power Long press "Enter" button to confirm the operation.
12		Clear the resettable energy Long press the Enter button to confirm the operation.
13		Password Default: 1000
13-1		Press the "Enter" button, the red part flash. Press the "Scroll" button to change the option. After choose the new "Scrl" option, the user needs to press the "Enter" button to confirm the setting.

3. Specifications

3.1 General Specifications

Voltage AC (Un)	230V
Voltage Range	176~276V AC
Base Current (Ib/Iref)	10A
Max. Current (Imax)	100A
Mini Current (Imin)	0.5A
Starting current	0.4% of Ib/Iref
Power consumption	<2W/10VA
Frequency	50Hz(for MID version) 50Hz(default),60Hz optional
AC voltage withstand	4KV for 1 minute
Impulse voltage withstand	6KV-1.2uS waveform
Over current withstand	30Imax for 0.01s
Pulse 1 output rate	configurable, default 1000/kWh
Pulse 2 output rate	non-configurable, 1000/kWh
Display	LCD with backlit
Max. Reading	999999.9kWh

3.2 Accuracy

Voltage	0.5% of range max.
Current	0.5% of nominal
Frequency	0.2% of mid-frequency
Active power	1% of range maximum
Reactive power	1% of range maximum
Apparent power	1% of range maximum
Active energy	Class 1 IEC62053-21 Class B EN50470-3
Reactive energy	1% of range maximum

3.3 Environment

Operating temperature	-25°C to +55°C
Storage/transportation temperature	-40°C to +70°C
Reference temperature	23°C ± 2°C
Relative humidity	0 to 95%, non-condensing
Installation category	CAT II
Mechanical Environment	M1
Electromagnetic environment	E2
Degree of pollution	2

*Maximum operating and storage temperatures are in the context of typical daily and seasonal variataion.

3.4 Pulse Output

The pulse output 1 can be set to generate pulses to represent total kWh, total kVarh, import kWh, export kWh, import kVarh, export kVarh.
Constant can be set to 1000/100/10/1 impulse per kWh or Kvarh.
Pulse width 200/100/60mS.

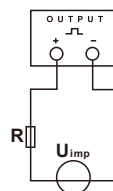

ATTENTION: Pulse output must be fed as shown in the wiring diagram below. Scrupulously respect polarities and the connection mode. Opto-coupler with potential-free SPST-NO Contact.
Contact range:5~27VDC Max. current Input:27mA DC.

3.5 RS485 output for Modbus RTU

The meter provides a RS485 port for remote communication. Modbus RTU is the protocol applied. For Modbus RTU, the following RS485 communication parameters can be configured from the Set-up menu.
Baud rate: 1200, 2400, 4800, 9600 bps
Parity: NONE/EVEN/ODD
Stop bits: 1 or 2
Modbus Address: 1 to 247

3.6 Mbus

The meter provides a Mbus Port for remote communication. the meter adopts EN1434-3 Mbus communication protocol. The communication parameters can be configured via the SET-UP mode.
Baudrate: 300,600,1200,2400,4800,9600 bps
Parity: None/Odd/Even
Stop bit: 1 or 2
Primary address: 001~250
Secondary address: 00000001~99999999

3.7 Mechanics

Din rail dimensions	36x99x63 (WxHxD)
Mounting	Per DIN 43880
Sealing	DIN rail 35mm
Material	IP51 (indoor) self-extinguishing UL94V-1

4. Dimensions

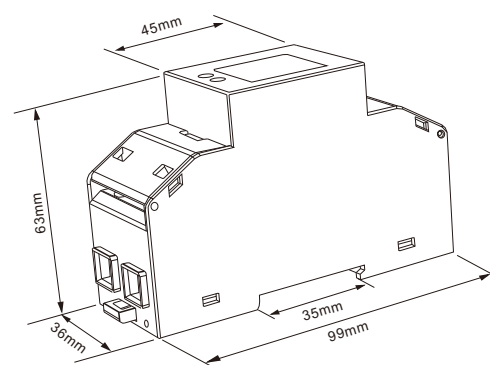

5. Installation and sealing

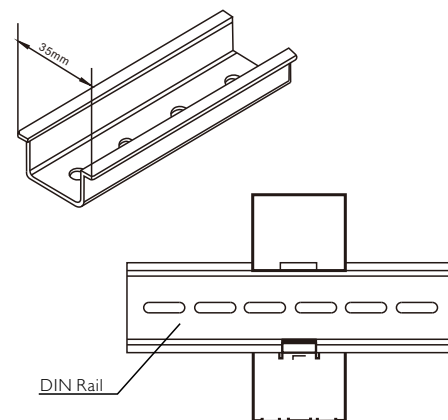

6. Wiring diagram

6.1 SDM230-V1

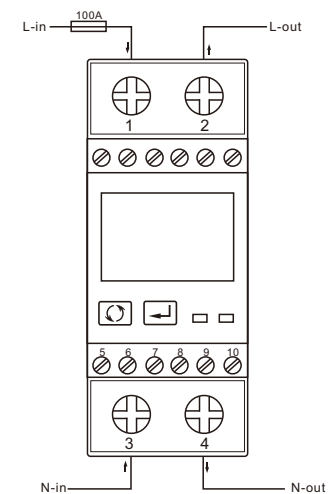

6.2 SDM230-V2

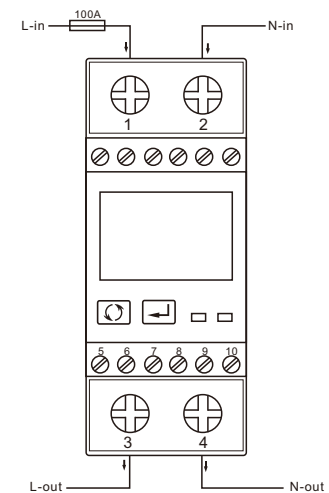

6.3 Definitions of other terminals

SDM230-2T



SDM230-Modbus



SDM230-Mbus

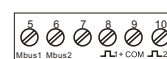

Smart Process & Control LTD
Unit 11, Totman Close,
Brook Road Industrial Estate,
Rayleigh, Essex,
SS6 7UZ
Telephone: 01268 773422
www.smartprocess.co.uk



Declaration of Conformity(for the MID approved version meter only)

We Zhejiang Eastron Electronic Co.,Ltd.
Declare under our sole responsibility as the manufacturer that the poly phase multifunction electrical energy meter "SDM230 series" correspond to the production model described in the EC-type examination certificate and to the requirements of the Directive 2014/32/EU EC type examination certificate number 0120/SGS0206. Identification number of the NB0120