

Data Sheet

2018 v1.0

SDM120-Series

DIN Rail Multifunction Power Meter

- MID B&D Approved
- Class B (kWh) EC Directive 2004/22/EC
- SDM120 Modbus (Pulsed & Modbus RTU Output)
- SDM120 MBus (Pulsed & Mbus Output)
- SDM120 Pulse (Pulsed Output Only)
- Digital Backlit Display



SDM120-Series Single Phase kWh Meter

The SDM120 family of meters have been produced to offer a low-cost solution to metering low Amp circuits. The SDM120 range work directly connected to a maximum load 45A AC circuit.

The SDM120 measures a vast range of parameters, including Voltage, Current and Power Factor. There are also 3 models available depending on the output required, this ranges from a just pulsed output (SDM120-Pulse), Modbus RTU (SDM120-Modbus), and MBus (SDM120-MBus).

All SDM120 meters are housed in a 1 Module DIN rail-mounted housing. They also come complete with sealable terminal covers to stop any tampering with the connections.

Dimensions

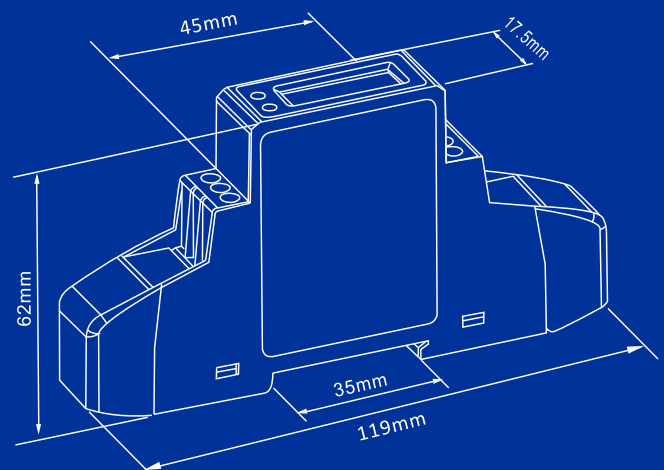

Measured Parameters

The SDM120 monitors and displays the following parameters of a single phase two wire (1p2w) system:

- Voltage (V)
- Current (A)
- Active Power (kW)
- Power Factor (PF)
- Frequency (Hz)
- Import Active Energy (kWh)
- Export Active Energy (kWh)
- Total Active Energy (kWh)

Voltage and Current

- Phase to Neutral Voltage - 176 to 276V AC
- Phase Current - Imin-Ib(I_{max}) 0.25-5(45)A AC

Power factor and Frequency and Max. Demand

- Frequency in Hz
- Instantaneous power:
- Power 0 to 12 kW
- Reactive power 0 to 12 kVAr
- Volt-amps 0 to 12 kVA
- Maximum demanded power since last Demand reset Power factor

Energy Measurements

Imported/Exported active energy	0 to 99999.99 kWh
Imported/Exported reactive energy	0 to 99999.99 kVArh
Total active energy	0 to 99999.99 kWh
Total reactive energy	0 to 99999.99 kVArh

Measured Inputs

Nominal Voltage Input	(Ph+N) 176 to 276V
Max Continuous Voltage	120% of nominal
Nominal Input Current	5(45)A
Max Continuous Current	120% of nominal
Frequency	50Hz (±10%)

Accuracy

Voltage	0.5% of range maximum
Current	0.5% of nominal
Frequency	0.2% of mid-frequency
Power factor	1% of unity (0.01)
Active power (W)	±1% of range maximum
Reactive power (VAr)	±1% of range maximum
Apparent power (VA)	±1% of range maximum
Active energy (Wh)	Class 1 IEC 62053-21
Reactive energy (VARh)	±1% of range maximum

Interfaces for External Monitoring

Two interfaces are provided:

- RS485 communication channel that can be programmed for Modbus RTU protocol
- Relay output indicating real-time measured energy.(configurable)

The Modbus configuration (baud rate etc.) and the pulse relay output assignments (kW/kVArh, import/export etc.) are configured through modbus interrogation.

SDM120-M-Bus

The meter provides a M-bus port for remote communication. M-bus protocol is applied.

Baud rate 300, 600/1200/2400/4800/9600

Parity none (default) / even/ odd

Stop bits 1 or 2

Primary Address number 1 to 250

Secondary Address: 00 00 00 01 to 99 99 99 99

SDM120-Pulsed Output

The meter provides two pulsed outputs, both pulsed outputs are passive type. The first pulsed output is configurable. The pulsed output can be set to read total / import / export/ kWh / kWh. The pulse constant can be set to generate 1 pulse per: 0.001(default) /0.01/0.1/1kWh/kWh. The second pulsed output is non-configurable. It is fixed to read total kWh.

Rate can be set to generate 1 pulse per:

0.001 = 1 Wh/VArh (default)

0.01 = 10 Wh/VArh

0.1 = 100 Wh/VArh

1 = 1 kWh/kVArh

Pulse width 200/100/60 ms.

SDM120-Modbus (RS485 Output for Modbus RTU & Pulsed Output)

For Modbus RTU, the following RS485 communication parameters can be configured through modbus interrogation:

Baud rate 1200, 2400, 4800, 9600.

Parity none (default) / odd / even

Stop bits 1 or 2

RS485 network address 3-digit number, 1 to 247

Reference Conditions of Influence Quantities

Influence Quantities are variables that affect measurement errors to a minor degree. Accuracy is verified under nominal value (within the specified tolerance) of these conditions.

Ambient temperature	23°C ±1°C
Input waveform	50 or 60Hz ±2%
Input waveform	Sinusoidal (distortion factor < 0.005)
Auxiliary supply voltage	Nominal ±1%
Auxiliary supply frequency	Nominal ±1%
Auxiliary supply waveform (if AC)	Sinusoidal (distortion factor < 0.05)
Magnetic field of external origin	Terrestrial flux

Environment

Operating temperature	-25°C to +55°C*
Storage temperature	-40°C to +70°C*
Relative humidity	0 to 95%, non-condensing
Altitude	Up to 3000m
Warm up time	1 minute
Vibration	10Hz to 50Hz, IEC 60068-2-6, 2g
Shock	30g in 3 planes

*Maximum operating and storage temperatures are in the context of typical daily and seasonal variation.

Mechanics

DIN rail dimensions	18mm x 90mm (WxH) per DIN 43880
Mounting	DIN rail (DIN 43880)

Wiring Diagram

