

OPERATOR'S MANUAL

ENGLISH

KUBOTA

DIESEL ENGINE GENERATOR

GL14000-USA

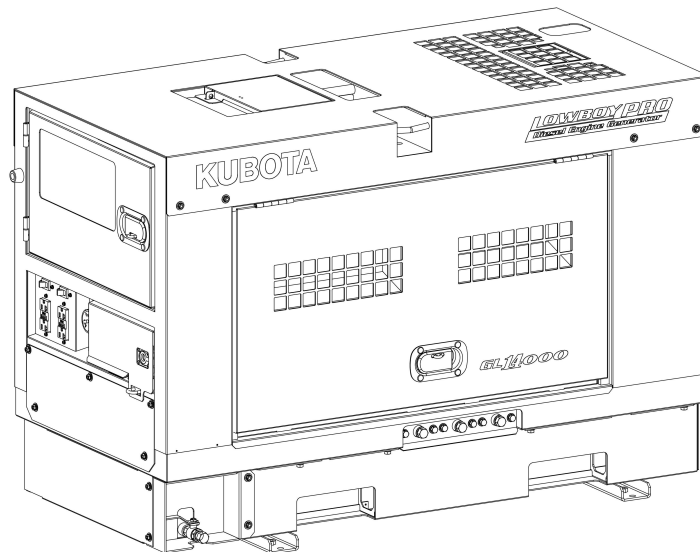

W0301-00319

READ AND SAVE THIS BOOK

Kubota

California Proposition 65

WARNING

Breathing diesel engine exhaust exposes you to chemicals known to the State of California to cause cancer and birth defects or other reproductive harm.

- Always start and operate the engine in a well ventilated area.
- If in an enclosed area, vent the exhaust to the outside.
- Do not modify or tamper with the exhaust system.
- Do not idle the engine except as necessary.

For more information go to www.P65warnings.ca.gov/diesel.

WARNING

Batteries, battery posts, terminals and related accessories contain lead and lead compounds, and other chemicals known to the State of California to cause cancer and birth defects or other reproductive harm. WASH HANDS AFTER HANDLING.

CAUTION

Do not operate the Generator, or any other appliance, until you read and understand the instructions for use and keep near for ready use.

Foreword

You are now the proud owner of a KUBOTA Diesel Engine Generator. This generator is a product of KUBOTA quality engineering and manufacturing. It is made of fine materials and under a rigid quality control system with correct maintenance; it will give you long satisfactory service. To obtain the best use of your generator, please read this manual carefully. It will help you become familiar with the operation of the generator and contains many helpful hints about generator maintenance. It is KUBOTA's policy to utilize as quickly as possible every advance in our research. Therefore, the immediate use of new techniques in the manufacture of products may cause some small parts of this manual to be outdated. KUBOTA distributors and dealers will have the most up-to-date information. Please do not hesitate to consult with them.

Introduction

Thank you for purchasing this KUBOTA diesel engine generator.

- This manual has been created to ensure safe usage of this generator. Be sure to read this manual before operation. Improper operation/handling of this generator may result in an accident or malfunction.
- Handling/Operation of this generator can only be performed by persons who understand the contents of this manual and can handle/operate the generator in a safe manner. Persons who suffer from an illness, are taking medicine or not feeling well such that safe operation would be negatively affected must not operate this generator.
- Work performed using this generator and handling/operation of this generator must be in accordance with corresponding laws and regulations based on such laws. Consult with KUBOTA distributors and dealers if you have any inquiries regarding the corresponding laws.



- Always be sure to include this manual when loaning out this generator and instruct operating personnel to read this manual before operation.
- Store this manual in a specified location where it will be secure and available for consulting at any time. Order another copy from KUBOTA distributors and dealers if this manual is lost or unreadable.
- Consult with KUBOTA distributors and dealers if you have any inquiries regarding any points related to this generator and manual.
When inquiring about this generator, be sure to provide the model name and serial number.
- If disposing of this generator, do so in a manner that is in compliance with laws related to industrial waste. Contact KUBOTA distributors and dealers if you have any inquiries regarding proper disposal.

Special Requirements

There may be General or State Occupational Safety and Health Administration (OSHA) regulations, local codes or ordinances that apply to the intended use of the generator. Please consult a qualified electrician, electrical inspector, or the local agency having jurisdiction:

- ▽ In some areas, generators are required to be registered with local utility companies.
- ▽ If the generator is used at a construction site, there may be additional regulations which must be observed.

- Caution notice ranks in this manual are classified as follows.

	DANGER: Indicates an imminently hazardous situation which, if not avoided, will result in death or serious injury.
	WARNING: Indicates a potentially hazardous situation which, if not avoided, can result in death or serious injury.
	CAUTION: Indicates a potentially hazardous situation which, if not avoided, can result in minor or moderate injury and property damage.
< Note >:	Other types of cautions and indications.

- Note that  **CAUTION** items can also lead to major accidents under some circumstances if not correctly followed.
All caution notices are important. Be sure to follow all of them.

Table of Contents

1. Safety Instructions	2
2. Specifications	6
2-1. Specifications	6
2-2. Ambient Conditions	7
3. Applications	7
4. Part Names	7
4-1. External View/Part Names	7
4-2. Control Panel Configuration	9
5. Equipment	10
5-1. Available Output Monitor	10
5-2. Spill Containment	10
5-3. Warning Indicators	11
5-4. Spill Containment Overflow Warning Indicator	13
5-5. Terminal Cover Switch.....	13
5-6. Meters and Gauges.....	14
6. Transport/Installation	16
6-1. Transport Procedures.....	16
6-2. Installation Procedures.....	17
7. Load Connections	17
7-1. Load Cable Selection	17
7-2. Connecting Load Cables	19
8. Pre-Operation Inspection	21
8-1. Checking Engine Oil.....	21
8-2. Checking Coolant.....	22
8-3. Checking the Fuel	23
8-4. Checking the Spill Containment	24
8-5. Checking for Fuel, Oil and Coolant Leak.....	24
8-6. Checking the Battery	24
9. Operating Procedures	25
9-1. Initial Startup/Pre-Check	25
9-2. Procedures during Operation	27
9-3. Stopping Operation	27
9-4. Protective Functions.....	28
10. Inspection/Maintenance	29
11. Long-Term Storage	39
12. Troubleshooting	40
13. Generator Circuit Diagram	43
14. Engine Electrical Circuit Diagram	44

1. Safety Instructions

DANGER: GROUNDING THE GENERATOR

To reduce the risk of electric shock, generator must be properly grounded. The National Electric Code contains several practical ways in which to establish a good ground source. If a steel or iron rod is used, it should be at least 5/8 in. Diameter, and if a nonferrous rod is used, it should be at least 1/2 in. diameter and be listed as material for grounding. Drive the rod or pipe to a depth of 8 ft. If a rock bottom is encountered less than 4 ft. down, bury the rod or pipe in a trench.

All electrical tools and appliances operated from this generator must be properly grounded by use of a third wire or be "Double Insulated."

It is recommended to:

1. Use electrical devices with 3-prong grounded plugs.
2. Use an extension cord intended for outdoor use with a 3-pole receptacle and a 3-prong plug at opposite ends to ensure continuity of the ground protection from the generator to the appliance.

Check and adhere to all applicable federal, state, and local regulations relating to grounding specifications. Consult a qualified electrician or service personnel if the grounding instructions are not completely understood or if in doubt as to whether the generator is properly grounded.

WARNING: WHEN THIS GENERATOR IS USED TO SUPPLY A BUILDING WIRING SYSTEM

Generator must be installed by a qualified electrician and connected to a transfer switch as a separately derived system in accordance with NFPA 70, National Electrical Code. The generator shall be connected through a transfer switch that switches all conductors other than the equipment grounding conductor. The frame of the generator shall be connected to an approved grounding electrode. Failure to isolate the generator from power utility can result in death or injury to electric utility workers.

WARNING: EXHAUST GAS POISONING

- Do not operate the generator in poorly ventilated areas such as indoors or tunnels, as the exhaust gas of the engine contains substances that are harmful to human health.
- Do not direct exhaust fumes at bystanders or buildings.

WARNING: ELECTRIC SHOCK

- Do not operate the equipment with access doors or covers open.
- Before connecting or disconnecting load cables to/from the output terminal, always turn the output circuit breakers to the OFF position, stop the engine, and remove the starter key.
- Close the output terminal cover before operating.
- Do not insert a pin, wire or other metal object into the electrical outlet.
- Do not touch the generator if the generator or your body becomes wet during operation.
- Do not touch internal electric parts while the generator is operating.
- Always be sure to stop the engine and remove the starter key before performing any equipment check or maintenance.

⚠ WARNING: INJURY 

- Close all doors and lock them during operation.
- Do not open the access door during operation. Avoid moving parts such as the cooling fan and fan belt.
- Always be sure to stop the engine and remove the starter key when performing inspection or maintenance.
- Use the lifting hook to lift the machine, and do not lift up by using tie downs. Use of such could result in the generator falling.
- Do not lift any additional weight such as fuel tanks or trailers.
- No persons should be under a suspended generator at any time.
- Always be sure to check that the breakers on load side and switches for any equipment using the generator are at OFF before turning the breaker to ON. Also be sure to advise personnel on the load side that power will be turned on or off before operating the breaker.
- Do not modify the equipment and do not operate with parts removed.

⚠ CAUTION: EYE/SKIN INJURY 

- Wear rubber gloves and other protective wear to protect eyes, skin and clothing from the battery fluid which contains diluted sulfuric acid. If the battery fluid contacts eyes or skin, wash out immediately with a sufficient amount of clean water. Be sure to receive medical treatment, especially if the fluid contacts the eyes.

⚠ CAUTION: EXPLOSION 

- Never use or recharge the battery if the fluid level is below the minimum level.
- Do not create sparks or bring flame near the battery as it generates flammable gas.

⚠ CAUTION: PROPERTY DAMAGE

- Do not use the equipment for any improper applications. Improper usage can result in an accident or malfunction.
- If using this generator for medical equipment, check before use with the medical equipment manufacturer, doctor, hospital or similar entity.
- Check that the generator output setting, output terminal connection and load power source are consistent.
- Cable burnout can occur due to generated heat if the load current exceeds the allowable current of the cable.
- The voltage drop between cables is large if the cable is excessively long or thin; resulting in decreased input voltage to equipment using the generator, thereby causing decreased performance, faulty operation and malfunction.

⚠ CAUTION: ELECTRIC SHOCK 

- Do not sprinkle water on the equipment and do not use where exposed to rain.

 **CAUTION: FIRE**  

- Do not carry flammable items (such as fuel, gas and paint) or items that are highly combustible near the generator as the muffler, exhaust gas and other parts become extremely hot.
- Position this generator 3 ft. (1 m) or more from walls or other hindrances, and on a firm and level surface.
- Use circuit protection between generator and load.
- This generator uses diesel fuel. Always be sure to stop the engine and not bring flames close when inspecting fuel or refueling. Wait until the engine has cooled before inspecting or refueling.
- If fuel spills, always be sure to open the spill containment drain valve and drain off the spilled fuel.
- Do not operate the equipment with liquid accumulated in the spill containment.
- If fuel or oil is leaking, repair the leaking location before operating.
- Always be sure to wipe up any spilled fuel or oil before starting the engine.
- Allow the generator to cool before covering with the protective cover.
- Never allow flame to come close to the generator.
- Always make sure that the engine is stopped when working on piping.
- After working on the piping, check that there is no fuel leakage.
- Never inspect or perform maintenance to the equipment near fire or other open flame.
- Check to see if electric cable and wiring are swollen, hardened or cracked, replace cables if conditions are found.
- Keep dust and water away from all power connections.
Loose wiring and Terminal parts make bad connections, be sure to repair them before starting the engine.

 **CAUTION: BURNS**  

- Do not touch the engine and surrounding components immediately after stopping the engine as they are still extremely hot.
- Do not open the radiator cap immediately after stopping the engine. Doing so will result in hot steam gushing out.
- Hot steam gushes out from the coolant sub-tank if the generator overheats. Do not touch the coolant sub-tank.
- Always be sure to stop the engine and allow the engine to cool when performing inspection or maintenance of engine oil. Opening the oil level indicator or oil filler cap during operation will result in hot oil gushing out.

 **CAUTION: INJURY**   

- Always be sure to use lifting hooks when lifting up the generator, and slowly lift it straight up.
- Personnel performing lifting work must wear protective gear such as helmets, safety shoes and gloves.
- Remove the wood ties if using anchors to secure the generator
- Position the generator on a level stable surface so that it cannot slide or move in any manner.
- Before starting operation, always be sure to turn off all switches of equipment using the generator and all breakers to OFF.
- Do not move the generator during operation.
- Do not operate the generator if it has been modified or any parts have been removed.
- Securely fix the equipment with rope or similar item so that it cannot move when transporting by truck or other vehicle.

■ Warning /Caution Label Locations

If warning or caution labels become damaged and difficult to read, contact your local distributor for replacement Labels.

- ① Warning: Injury
- ② Warning Caution
- ③ Warning: Fire
- ④ Caution: GM SPEC LLC
- ⑤ EPA Regulation Complied Notice
- ⑥ Warning: Electric shock
- ⑦ Spill Containment Desorption
- ⑧ Never use inside a home
- ⑨ Caution: No Fork
- ⑩ Warning: Proposition 65 Gen
- ⑪ Warning: Proposition 65 Battery

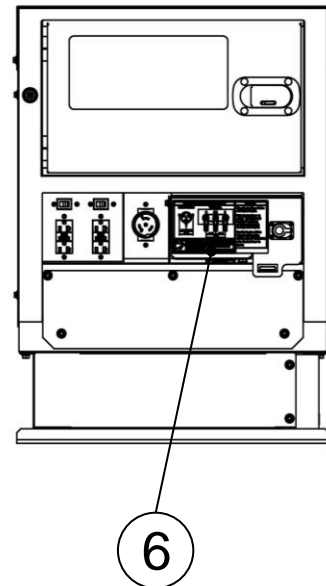
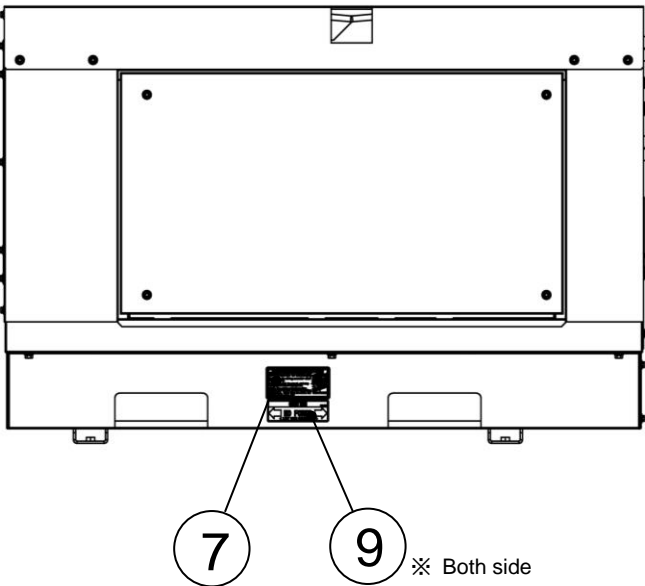
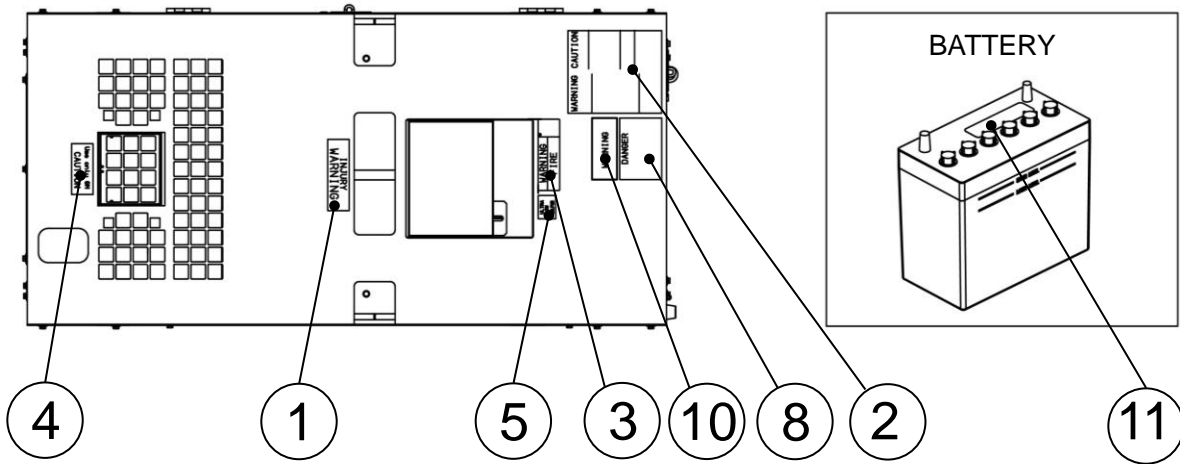

2. Specifications

2-1. Specifications

Model		Unit		GL14000-USA
Alternator	Generator Type	-		Revolving Field Brushless
	Armature Connection	-		ZigZag-W
	Rated Frequency	Hz		60
	Rated Output(Prime)	kVA		12
		kW		12
	Standby Output	kVA		14
		kW		14
	Rated Voltage	V		120/240
	Rated Current	120V	A	50×2
		240V	A	50
	Power Factor	-		1.0
	Insulation class	-		F
Excitation	-		Self-Excitation (brushless)	
No. of Poles	-		2	
Engine	Type	-		Vertical Water-Cooled 4-Cycle Diesel
	Model(Manufacturer)	-		D902(KUBOTA)
	No. of Cylinders (bore x stroke)	(in./mm)		3(2.83x3.78/72x73.6)
	Continuous Rated Output	hp		20.7
	Rated Speed	rpm		3,600
	Displacement	cu.in./liters		55/0.898
	Combustion System	-		Indirect Injection
	Cooling Method	-		Water cooled
	Starting Method	-		Electric
	Fuel	-		No.2-D,S15 EPA regulation
	Lubricating Oil	-		API service-type CD class or better
	Fuel Tank Capacity	gal./liters		9.6/36.4
	Lubricant Volume	gal./liters		0.95/3.6
	Coolant Volume	gal./liters		1.1/4.1(including sub-tank 0.16/0.6)
	Starting Motor Capacity	V-kW		12-1.2
Charging Alternator Capacity	V-W		12-150	
Battery Capacity	V-Ah		12-36	
Unit	Length	in./mm		52/1,310
	Width	in./mm		25/640
	Height	in./mm		35/895
	Dry Weight	lbs./kg		904/410
	Net Weight	lbs./kg		1,003/455

2-2. Ambient Conditions

Use this generator in ambient conditions as described below. Failure to provide these conditions can result in problems such as malfunction, insufficient output and reduced durability.

- Ambient temperature: 5 to 104 °F (-15 to 40 °C)
- Relative humidity: 80% or less
- Altitude: 984 ft. (300 m) or less

3. Applications

- Power source for submerged pumps and similar civil engineering equipment
- Power source for lighting and similar equipment
- Power source for electrical tools and household appliances



CAUTION : PROPERTY/SECONDARY DAMAGE

- Do not use for any application other than those listed above.
- If using this generator for medical equipment, check before use with the medical equipment manufacturer, doctor, hospital or similar entity.

4. Part Names

4-1. External View/Part Names

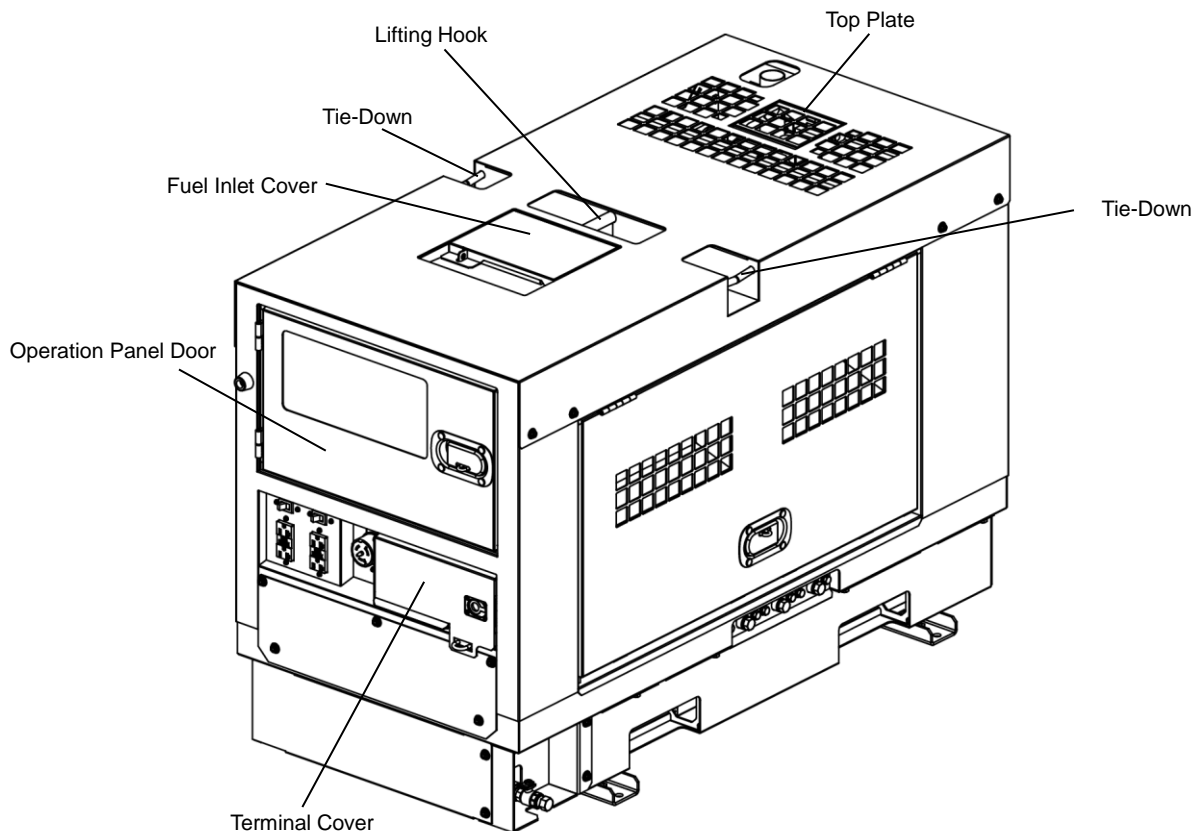

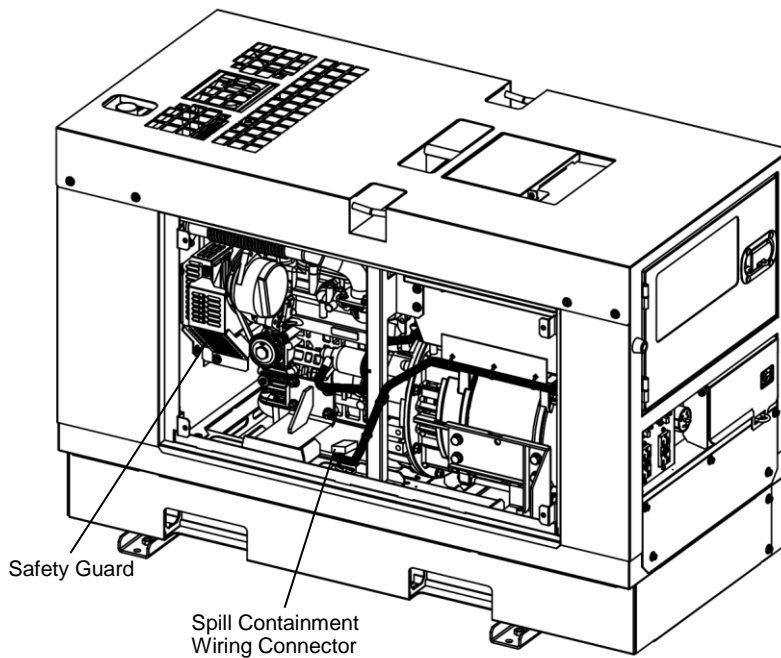

*Shown with side-plate removed.

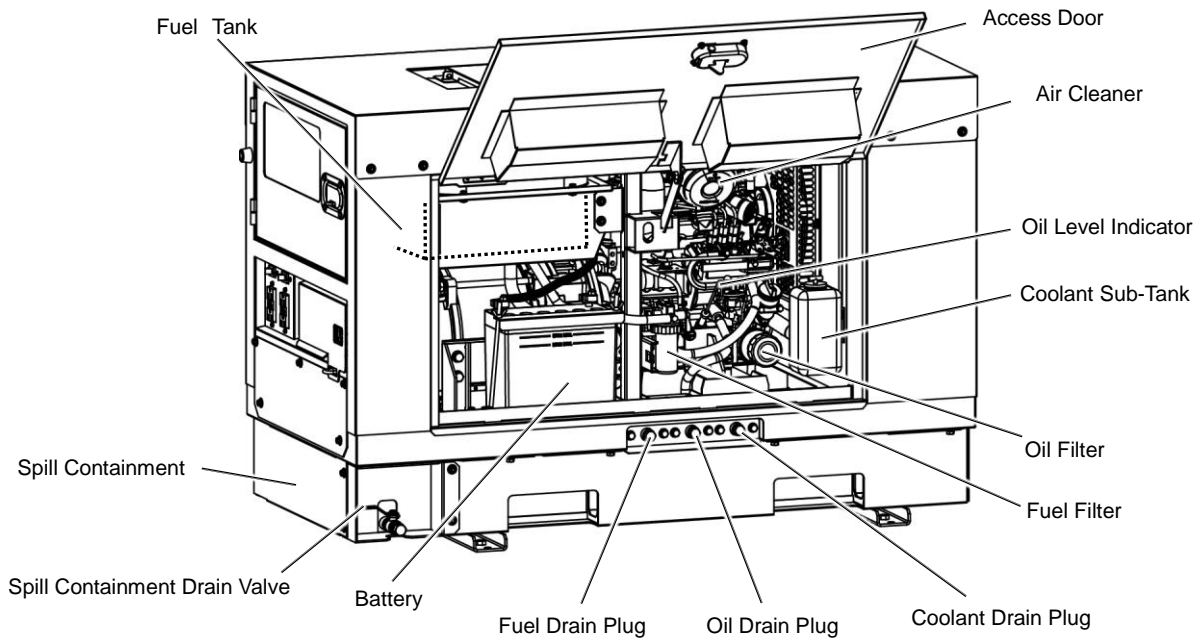

Accessories

Operator's
Manual

Engine
Warranty
Manual



Starter Key (2 pieces)

4-2. Control Panel Configuration

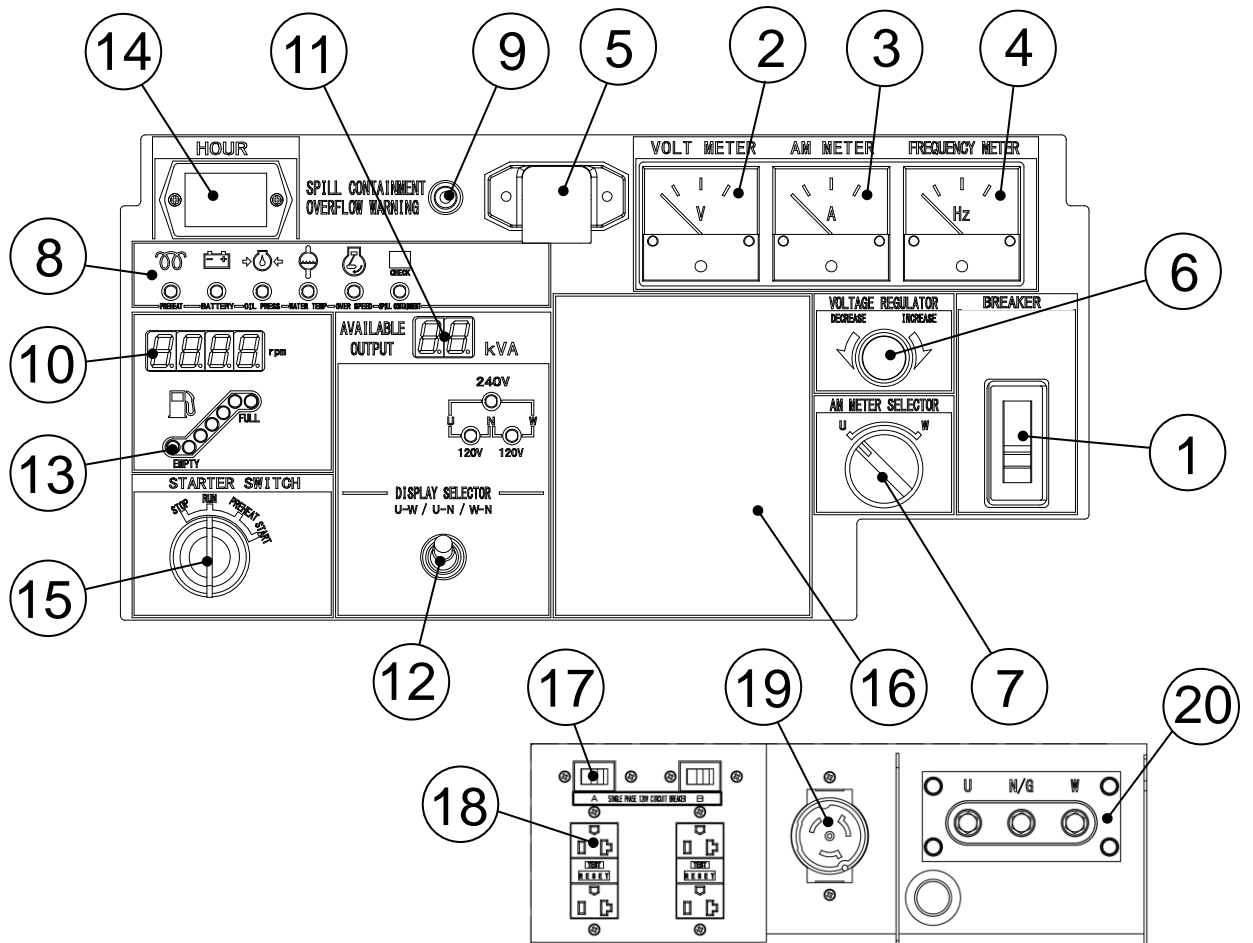

①	Main Circuit Breaker	⑪	Available Output Monitor
②	Voltmeter	⑫	Display Selector Switch
③	Ammeter	⑬	Fuel Meter
④	Frequency Meter	⑭	Hour Meter
⑤	Pilot Lamp	⑮	Starter Switch
⑥	Voltage Regulator	⑯	Auto start Panel (Optional)
⑦	Ammeter Selector Switch	⑰	Circuit Breaker
⑧	Warning Indicators	⑱	240/120V-Receptacle (CS6369)
⑨	Spill containment Overflow Warning Indicator	⑲	240/120V-Receptacle (CS6369)
⑩	Tachometer	⑳	Output Terminal

5. Equipment

5-1. Available Output Monitor

The available generated output for each output power source is displayed digitally. You can use the display selector switch to change the display in the following order: single-phase three-wire U-W output, and single-phase three-wire U-N output, and single-phase three-wire W-N output. Output of single-phase three-wire U-W is always displayed when the engine is started.

< Note >

- Consider the digitally displayed available output as an approximate estimate. Be sure to thoroughly consider the displayed value and the used load capacity when using a load such as a motor with large starting capacity.
- If “-” is displayed for the available output, it means that usage has exceeded the rated capacity. Immediately stop the equipment being used and reduce the load capacity of the equipment.

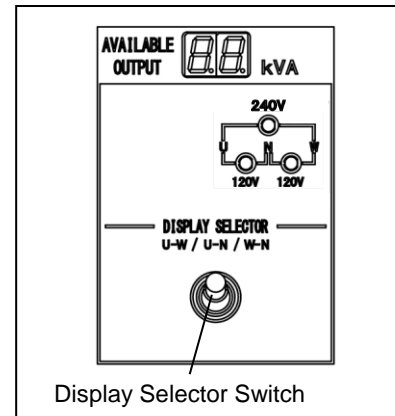

5-2. Spill Containment



- Do not open the access door during operation. Avoid moving parts such as the cooling fan and fan belt.
- Always be sure to stop the engine and remove the starter key when performing inspection or maintenance.



- Do not touch the engine and surrounding components immediately after stopping the engine as they are still extremely hot.

The bed of this generator is equipped with a spill containment (structure for preventing leakage of liquid) so that any spilled liquid will not leak to outside of the generator when oil or fuel is spilled or leak. Before starting operation, check if there is accumulated liquid in the spill containment. Flush out any liquid that has accumulated.

(Refer to section “8-4. Checking the Spill Containment” for inspection procedures.)

(Refer to section “10. Inspection/Maintenance (9) Flushing Liquid in Spill Containment” for flushing procedures.)

The generator is equipped with the following in order to prevent liquid from spilling in case you forget to flush liquid: The operation panel is equipped with an indicator that illuminates when its sensor is triggered as the spill containment capacity accumulated enough liquid to reach the about 4.1gal. (15.4 liters).



If the liquid stored in the spill containment exceeds approximately about 13.7gal. (51.7 liters) during operation, the SPILL CONTAINMENT overflow warning indicator illuminates, and the engine will be automatically stopped. If this occurs, flush the liquid stored in the spill containment.

(Refer to section “10. Inspection/Maintenance (9) Flushing Liquid in Spill Containment”.)



< Note >

- Water can also accumulate in the spill containment due to rain entering into the generator. Accordingly, you should periodically flush liquid accumulated within the generator. However, you should flush water according to the frequency/amount of rainfall.
- The types of liquids that can accumulate in the spill containment include oil, fuel, coolant and battery fluid such that it is not possible to distinguish between rainwater and other liquids. Dispose of flushed liquids according to the applicable laws and regulations.

5-3. Warning Indicators

 **WARNING : INJURY**  

- Do not open the access door during operation. Avoid moving parts such as the cooling fan and fan belt.
- Always be sure to stop the engine and remove the starter key when performing inspection or maintenance.

 **CAUTION : BURNS** 

- Do not touch the engine and surrounding components immediately after stopping the engine as they are still extremely hot.

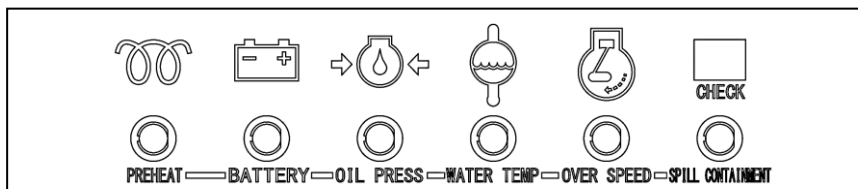

This generator is equipped with the following warning indicators: BATTERY (insufficient charging), OIL PRESS (engine oil pressure), WATER TEMP (coolant temperature), OVER SPEED (engine over-speed) and SPILL CONTAINMENT (spill containment amount). When the engine starts, all the lamps will light off. Moving the starter switch from STOP to RUN causes the BATTERY and OIL PRESS warning indicator to illuminate, and all of the indicator lights will go off as the engine starts. An indicator illuminates if a malfunction/fault occurs during operation and the engine automatically stops depending on the fault type (except for SPILL CONTAINMENT).

If the generator automatically stops, move the starter switch to STOP and restart the engine. Then check the lightning state of each warning indicator at the time of automatic stop, and inspect the abnormal part.

(1) BATTERY (Insufficient Charging) Warning Indicator (Low Battery Voltage)

The BATTERY warning indicator illuminates and the engine automatically stops when charging is not possible during operation. If this occurs, contact your local Authorized KUBOTA Engine America generator distributor or dealer.

< Note >

- This battery charging warning indicator cannot detect battery deterioration or insufficient battery fluid. (Refer to section “8-6. Checking the Battery”.)

(2) OIL PRESS (engine oil pressure) Warning Indicator (Low Oil Press.)



- Always be sure to stop the engine and allow the engine to cool when performing inspection or maintenance of engine oil. Opening the oil level indicator or oil filler cap during operation will result in hot oil gushing out.

If the engine oil pressure drops below 14 psi (0.98 x 100 kPa) during operation, the OIL PRESS warning indicator illuminates and the engine will be automatically stopped. If this occurs, check the engine oil level and add engine oil until it reaches the maximum level.

< Note >

- This oil pressure warning indicator cannot detect oil deterioration. Change the engine oil periodically. (Refer to section “8-1. Checking Engine Oil”.)

(3) WATER TEMP (Coolant Temperature) Warning Indicator (High Water Temp.)



- Do not open the radiator cap immediately after stopping the engine. Doing so will result in hot steam gushing out.
- Hot steam gushes out from the coolant sub-tank if the generator overheats. Do not touch the coolant sub-tank.

If the coolant temperature rises above 239 °F(115°C) during operation, the WATER TEMP warning indicator illuminates, and the engine will be automatically stopped. If this occurs, hot steam will gush out of the coolant sub-tank. Check the coolant sub-tank coolant level after the generator cools and add coolant to the coolant sub-tank if it is insufficient. (Refer to section “8-2. Checking Coolant”.) If the coolant is at the specified amount, it is probable that the fan belt is loose or there is a coolant leak. Wait for the engine to cool down and inspect for these problems.

< Note >

- The coolant temperature cannot be detected if the coolant level is excessively low. Always be sure to check the coolant level in the radiator coolant sub-tank before starting operation.

(4) OVER SPEED (Engine Overspeed) Warning Indicator

This generator is equipped with a function such that the engine is automatically stopped if an engine fault occurs causing the engine speed to increase excessively. If the engine speed rose above 4,140 rpm during operation, the OVER SPEED warning indicator illuminates, and the engine will be automatically stopped. If this occurs, contact your local Authorized KUBOTA Engine America generator distributor or dealer.

(5) SPILL CONTAINMENT (Spill Containment Amount) Checking Indicator

The SPILL CONTAINMENT checking indicator illuminates if liquid stored in the spill containment exceeds approximately 4.1gal.(15.4 liters) during operation. If it illuminates, immediately stop the engine and flush liquid stored in the spill containment. (Refer to section “10. Inspection/Maintenance (9) Flushing Liquid in Spill Containment”.)

< Note >

- The engine may not be stopped only if the spill containment checking Indicator illuminates during operation.
- When the spill containment checking indicator illuminates during operation, stop the engine, check for fuel, oil and coolant leakage, and repair as necessary.
- Do not use the equipment with liquid accumulated in the spill containment. Drain the spill containment before using.

5-4. Spill Containment (Spill Containment Amount) Overflow Warning Indicator

⚠ WARNING : INJURY 

- Do not open the access door during operation. Avoid moving parts such as the cooling fan and fan belt.
- Always be sure to stop the engine and remove the starter key when performing inspection or maintenance.

⚠ CAUTION : BURNS 

- Do not touch the engine and surrounding components immediately after stopping the engine as they are still extremely hot.

If liquid stored in the spill containment exceeds approximately 13.7gal. (51.7 liters) during operation, the SPILL CONTAINMENT overflow warning indicator illuminates, and the engine automatically stops. In that case, open the ACCESS DOOR and check inside the SPILL CONTAINMENT whether fuel and oil leak. If so, flush liquid stored in the spill containment after repairing the leaking spot.

(Refer to section “10. Inspection/Maintenance (9) Flushing Liquid in Spill Containment”.)

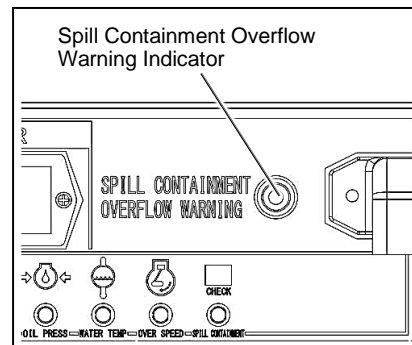

< Note >

- Although fluids that can leak internally consist of oil, fuel and coolant, the spill containment does not have a function that can separate rainwater that has leaked into the equipment from these internally leaked fluids. Properly dispose of liquid drained from the spill containment in a manner according to the applicable laws and regulations.

5-5. Terminal Cover Switch

The TERMINAL COVER SWITCH is safe device that detects the opening and/or closing at the terminal cover. While terminal cover is opened, the main breaker is tripped regardless of engine running and starter key ON. The main breaker will be tripped and the engine will be shut off immediately after terminal cover is opened during operation.

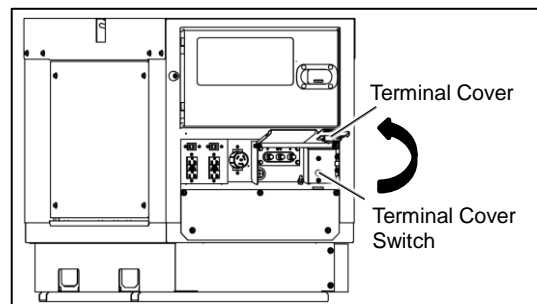

5-6. Meters and Gauges

Engine Meters and Gauges

(1) Hour Meter

Displays the operating time. Use this as a reference for managing periodic inspection interval.

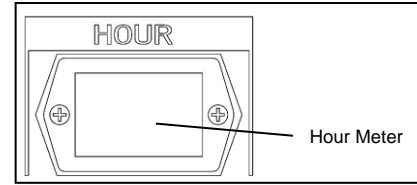

(2) Tachometer

Displays the engine speed. 3,600 rpm is displayed at 60 Hz.

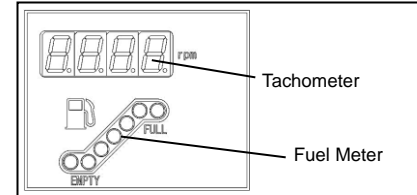

(3) Fuel Meter

Displays the amount of fuel in the internal fuel tank. When the tank is full, all the lamps are lit up and FULL is displayed. The amount of lamps lit up decreases as the amount of fuel decreases as it approaches EMPTY. Add fuel accordingly when only one lamp is displayed. The fuel meter on the control panel will only display the fuel level for the internal fuel tank.

Generator Meters and Gauges

(1) Voltmeter

The voltmeter displays the single-phase output voltage (voltage between U-W). Check that 240 V at 60Hz is displayed during operation.

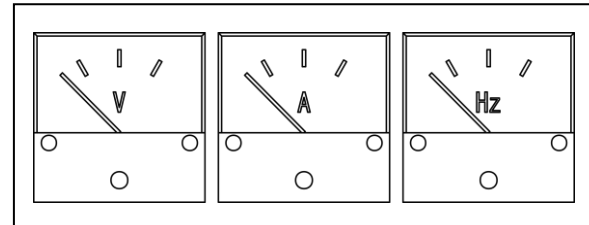

(2) Ammeter

Displays the output current (phase current) of the generator. Turn the ammeter selector switch to "U" to display the output current of the single-phase U phase. Turn the switch to "W" to display the output current of the single-phase W phase.

(3) Frequency Meter

Displays the frequency of the power source. Check that 60 Hz is displayed during operation.

Indicators

(1) Pre-heating Indicator

The pre-heating indicator illuminates when the starter switch is at PREHEAT. The pre-heating indicator turns off when pre-heating is completed to indicate that it is possible to start the generator.

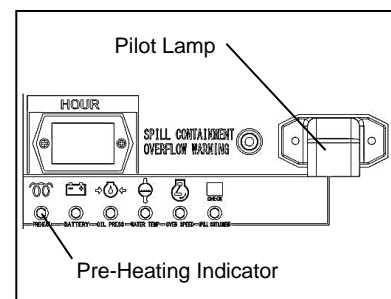

< Note >

- Pre-heating completes in approximately 5 seconds.

(2) Pilot Lamp

This illuminates when the engine is operating to indicate that power is being generated.

Switches

(1) Starter Switch

① STOP

The engine is stopped and all power is shut off with this position. The key can be inserted and removed only in this position.

② RUN

Position for operating the generator.

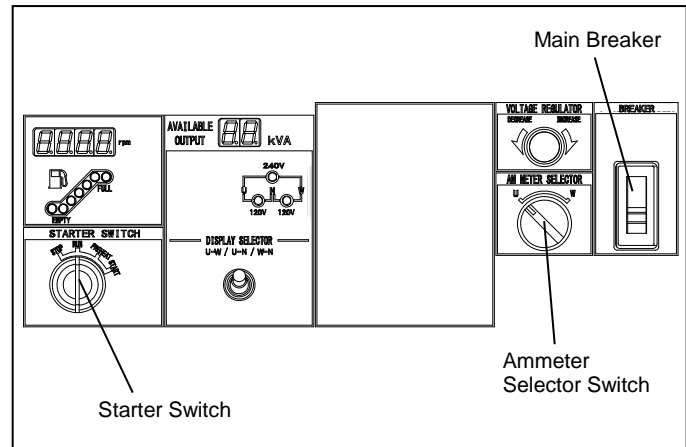

< Note >

- Do not leave the generator in this RUN position with the engine stopped. Doing so will cause the battery to drain.

③ PREHEAT

It is also the position for glow plug preheating for cold climate condition.

④ START

Position where the engine is started. If you remove your hand from the key, it returns to RUN automatically.

(2) Breaker

This switch is for transmitting electrical power to the load side. Turn to ON position to output voltage to the output terminals. Output to the load side is cut off when there is a short circuit or overload on the load side.

< Note >

- Do not turn off/on the breaker manually to operate or stop a load.

(3) Ammeter Selector Switch

This switch is for selecting the output current indicated by the ammeter. Change the switch to display the following output terminal current on the ammeter.

•Switch Selection

- "U": Single-phase three-wire U phase (total)
- "W": Single-phase three-wire W phase (total)

Voltage Regulator

(1) Voltage Regulator

This dial is for regulating voltage output by the generator. Turn the dial clockwise to increase the voltage and counterclockwise to decrease it.

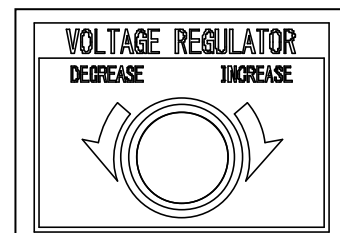

6. Transport/Installation

6-1. Transport Procedures

⚠ WARNING : INJURY



- Do not lift up the unit using tie down. Use of such could result in the generator falling.
- No persons should be under a lifted generator at any time.

⚠ CAUTION : INJURY

- Always be sure to use lifting hooks when lifting up the generator, and raise it slowly at a completely vertical angle.
- Personnel performing lifting work must wear protective gear such as helmets, safety shoes and gloves.
- Do not move the generator during operation.

(1) Lifting Procedures

Always be sure to use lifting hooks when lifting up the generator, and raise it slowly at a completely vertical angle.

(2) Transport

When transporting this generator, tie rope to the left and right tie downs, and securely fix the generator.

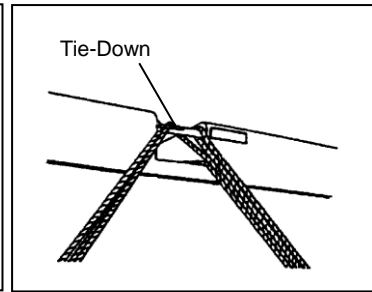
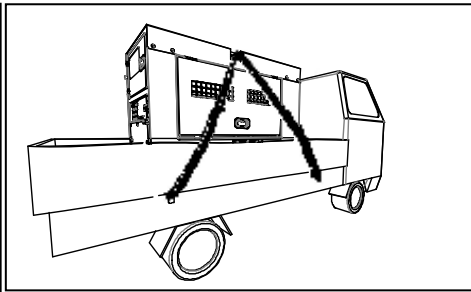
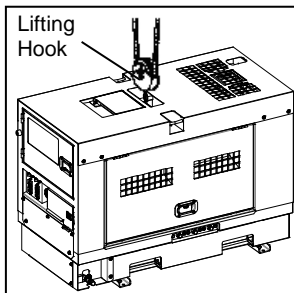

< Note >

- Handle this generator with great care when raising, lowering and transporting. Rough handling of generator can result in damage or malfunction.

6-2. Installation Procedures

WARNING : EXHAUST GAS POISONING

- Do not operate the generator in poorly ventilated areas such as indoors or tunnels, as the exhaust gas of the engine contains substances that are harmful to human health.
- Do not direct exhaust fumes at bystanders or buildings.

CAUTION : FIRE

- Do not carry flammable items (such as fuel, gas and paint) or items that are highly combustible near the generator as the muffler, exhaust gas and other parts become extremely hot.
- Operate this generator 3 ft. (1 m) or more from walls or other hindrances, and on a level surface.
- Remove the wood ties if using anchors to secure the generator.
- Use circuit protection between generator and load.

- If installing this generator, set up barriers or fencing completely around the boundary line of the construction area and take measures to prevent persons not involved in the construction from entering the area.
- Position this generator on a hard, flat and leveled surface.
- Position this generator 3 ft. (1 m) or more from walls or other hindrances so that the operation panel door and side/access doors are accessible for internal inspection/maintenance.

< Note >

- This generator is manufactured presupposing that it will be installed on a flat, hard and leveled surface. Accordingly, care must be taken as using under any other installation conditions can result in a fault or malfunction.
- Do not place any objects where they will interfere with the radiator or muffler exhaust ports. Objects interfering with these ports will result in reduced engine output, overheating, and electrical component fault/malfunction.
- Operating the equipment in dusty or excessively salty location can result in a clogged radiator or overheating resulting in malfunction/fault or reduced insulation of electrical components. Be sure to thoroughly inspect and perform maintenance if using in such locations.

7. Load Connections

7-1. Load Cable Selection

CAUTION : PROPERTY DAMAGE

- Cable burnout could occur due to generated heat if the load current exceeds the allowable current of the cable.
- The voltage drop between cables is large if the cable is excessively long or thin, resulting in decreased input voltage to equipment using the generator, thereby causing decreased performance, faulty operation and malfunction.

(1) Extension Cord Cable Size

Select cable for use that has sufficient thickness and an allowable current for use, and distance from the generator to the equipment using the generator.

Inadequate size cables can cause a voltage drop, which can burn out the appliance and overheat the cord.

Current in Amperes	Load in kW		Maximum Allowable Cord Length				
	At 120V	At 240V	#8 Wire	#10 Wire	#12 Wire	#14 Wire	#16 Wire
2.5	0.3	0.6		1000 ft.	600 ft.	375 ft.	250 ft.
5	0.6	1.2		500 ft.	300 ft.	200 ft.	125 ft.
7.5	0.9	1.8		350 ft.	200 ft.	125 ft.	100 ft.
10	1.2	2.4		250 ft.	150 ft.	100 ft.	50 ft.
15	1.8	3.6		150 ft.	100 ft.	65 ft.	
20	2.4	4.8	175 ft.	125 ft.	75 ft.		
25	3.0	6.0	150 ft.	100 ft.			
30	3.6	7.2	125 ft.	65 ft.			
40	4.8	9.6	90 ft.				
50	6.0	12	75 ft.				
100	12	24	35 ft.				

(2) Electric Motor Loads

It is characteristic of common electric motors in normal operation to draw up to six times their running current while starting. This table may be used to estimate the watts required to start electric motors; however, if an electric motor fails to start or reach running speed, turn off the appliance or tool immediately to avoid equipment damage. Always check the requirements of the tool or appliance being used compared to the rated output of the generator.

Motor Size (H.P.)	Running kW	kW Required to Start Motor		
		Universal	Capacitor	Split Phase
1/8	0.275	N/A	0.85	1.20
1/6	0.275	0.60	0.85	2.05
1/4	0.400	0.80	1.05	2.40
1/3	0.450	0.95	1.35	2.70
1/2	0.600	1.00	1.80	3.60
3/4	0.850	1.20	2.60	-
1	1.100	N/A	3.30	-

< Note >

- Operating voltage and frequency requirement of all electronic equipment should be checked prior to plugging them into this generator. Damage may result if the equipment is not designed to operate within a +/- 10% voltage variation, and V+/- 3 Hz frequency variation from the generator name plate ratings. To avoid damage, always have an additional load plugged into the generator if solid state equipment (such as a television set) is used. A power line conditioner is recommended for some solid state applications.

7-2. Connecting Load Cables

⚠ WARNING : ELECTRIC SHOCK

- Before connecting or disconnecting the load cables to/from the output terminal, always turn the output circuit breakers to the OFF position, stop the engine, and remove the starter key.
- Close the output terminal cover before operating.
- Do not insert a pin, needle or other metal object into the receptacle.
- Do not touch the generator if the generator or your body becomes wet during operation.

⚠ CAUTION : FIRE

- Do not connect the generator output to indoor wiring.
- A transfer switch **must** be used when connecting to a household load center.

< Note >

- When connecting a load, check that the generator output setting, output terminal connection position, and load power source are all matching.
- If using the N/G terminal, be careful that the currents of each phase are uniform.
- Use proper tools when connecting a load to sufficiently tighten the connection. Failure to sufficiently tightening will result in cable burnout.
- Terminal cover must remain closed during operation or main breaker will trip and the engine will be automatically stopped.

(1) Single-Phase Three-Wire Output Terminal and Receptacle

■ For single-phase three-wire type load:

- U-W terminal voltage is 240 V.
- U-N terminal voltage is 120 V.
- W-N terminal voltage is 120 V.

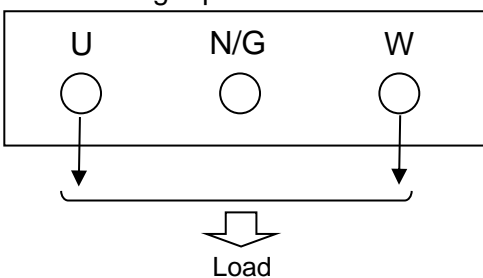

■ For single-phase 120 V load:

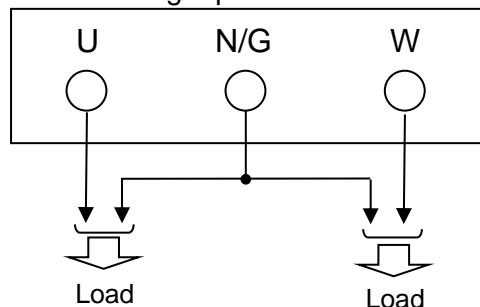

■ Single-phase 120V receptacle, single-phase 240/120V receptacle.

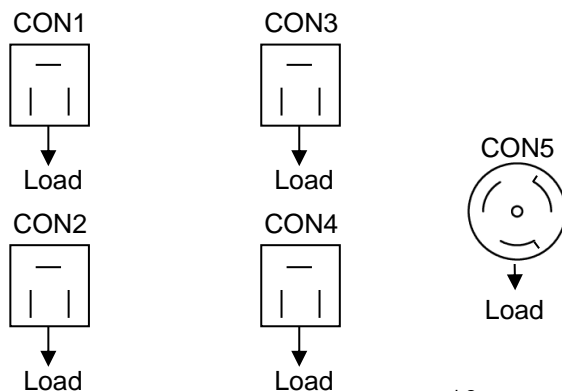

■ Power available for use by each output terminal and receptacle are as show below.

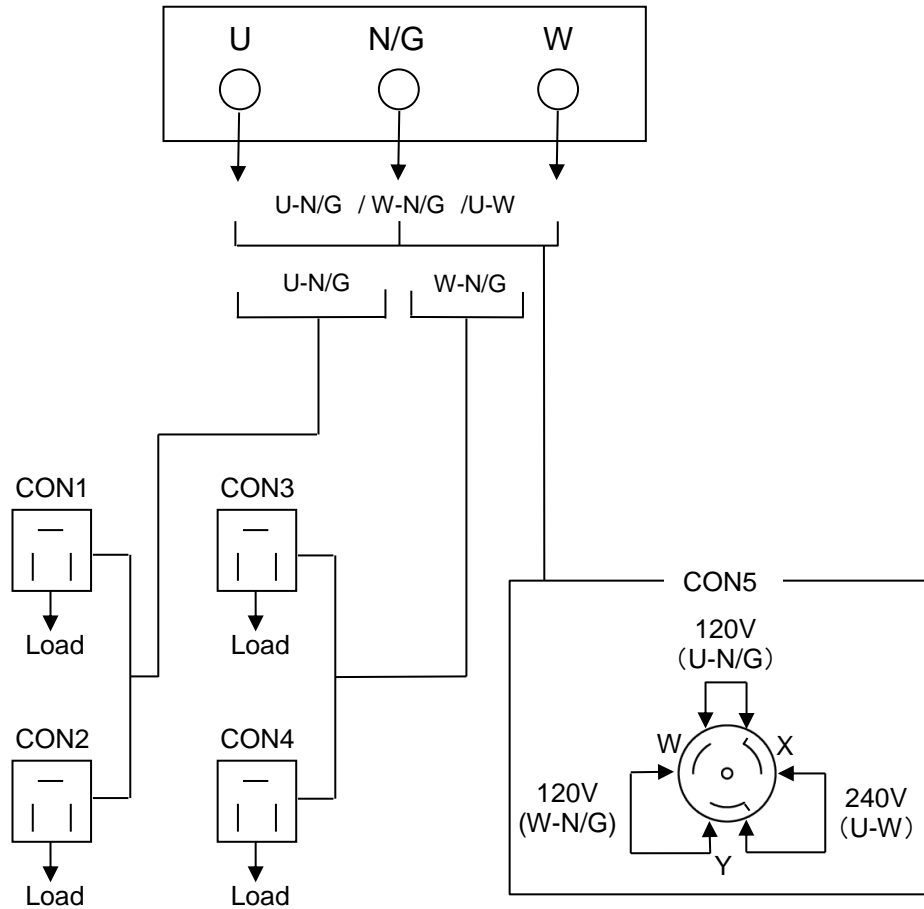

The use is possible up to the kVA as shown below.

1-phase, 3-wire output terminal		1-phase 120 V receptacle				1-phase 240/120 V receptacle	Total
		CON1	CON2	CON3	CON4	CON5	
U-W	12	—	—	—	—	12	
U-N/G	6	2.4	—	—	12	6	
W- N/G	6	—	—	2.4	—	6	

< Note >

- If using a single-phase 120 V (between output terminals U-N/G and W-N/G), connect an equivalent load between U-N/G and W-N./G
- If using a single-phase three-wire output terminal simultaneously with a receptacle output, make sure that currents passing through each phase are less than the rated current of this generator.

8. Pre-Operation Inspection

⚠ WARNING : INJURY

- Always be sure to stop the engine and remove the starter key when performing inspection or maintenance.
- Do not open the access door during operation. Avoid moving parts such as the cooling fan and fan belt.

⚠ CAUTION : BURNS

- Do not touch the engine and surrounding components immediately after stopping the engine as they are still extremely hot.

⚠ CAUTION : FIRE

- Always be sure to wipe up any spilled fuel or oil before starting the engine.
- Do not carry flammable items (such as fuel, gas and paint) or items that are highly combustible near the generator as the muffler, exhaust gas and other parts become extremely hot.
- Position this generator 3 ft. (1 m) or more from walls or other hindrances, and on a firm and level surface.
- Always be sure to wipe up any spilled fuel or oil before starting the engine.

8-1. Checking Engine Oil

To check the engine oil, keep the equipment in leveled position, remove the oil level indicator and wipe so that no oil remains, and then re-insert the dipstick fully. Prior to starting the engine, make sure to fill the engine oil through the oil filler until it reaches the MAX line.

< Note >

- Wait at least five minutes or more after stopping the engine before checking the oil level again.
- An accurate oil level reading cannot be obtained if the generator is not placed in leveled position.
- Do not overfill with oil to avoid engine damage.
- Do not tilt or move the generator while it is running since this can cause fuel spillage.

(1) Types of Engine Oil

Use only SAE CF class or better.

(2) Engine Oil Viscosity Grades

Use a diesel engine oil with an appropriate viscosity corresponding to the ambient temperature (refer to the table).

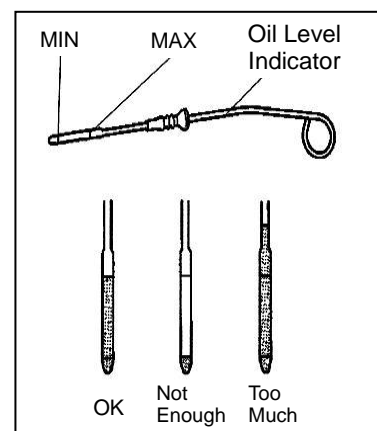
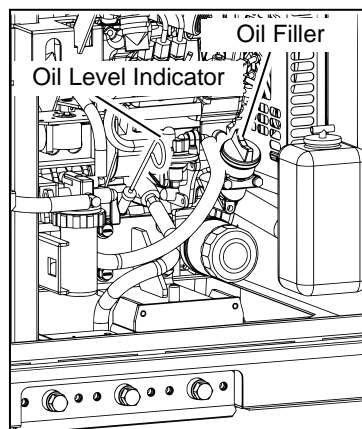

○ Relation of Viscosity/Temperature

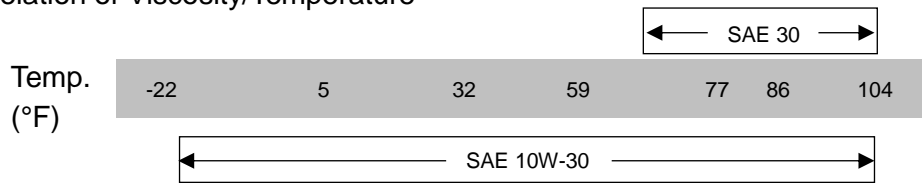

(3) Engine Oil Replacement Amount

Total Lubrication Oil Amount
0.95 gal.

8-2. Checking Coolant

⚠ CAUTION : BURNS

- Do not open the radiator cap immediately after stopping the engine. Doing so will result in steam gushing out.
- Hot steam gushes out from the coolant sub-tank if the generator overheats. Do not touch the coolant Sub-Tank.

Check that the Sub-Tank coolant level is between FULL and LOW. If the Sub-Tank coolant is lower than the LOW level, add coolant to the Sub-Tank and radiator.

(1) Filling the Sub-Tank

- 1 Remove the sub-tank cap.
- 2 Fill the sub-tank with coolant until it reaches the FULL line.
- 3 Re-attach the cap.

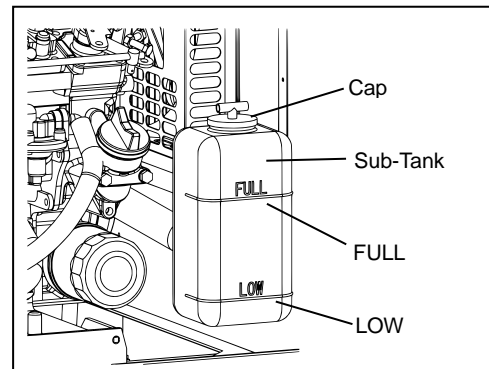

(2) Filling the Radiator

- 1 Open the top plate.
- 2 Remove the radiator cap.
- 3 Fill with coolant through the filler neck until the radiator is full.
- 4 Re-attach and tighten the radiator cap.
- 5 Close the top plate.

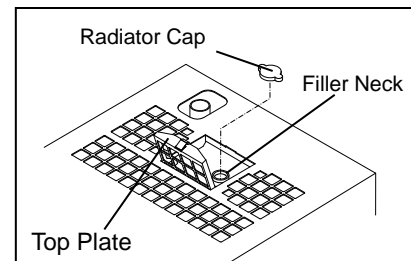

< Note >

- Use GM SPEC 6277M or equivalent.
- Use a 50:50 mix of Long Life Coolant (LLC).
- Always use potable water when mixing the coolant.
- Use LLC with the same mixture ratio in the coolant sub-tank.
- Do not increase the LLC mixture ratio unless it is necessary. Doing so could result in overheating or another fault/malfunction.

- If adding LLC, be sure to use the same brand/type that is still in the generator.
- Do not mix different brands/types. Doing so could result in a chemical reaction and the creation of toxic substances.
- Change the LLC every 2 years or 1,000 hours.
- LLC is a toxic substance. Wear rubber gloves and other protective wear when handling.
- If someone mistakenly ingests LLC, induce vomiting immediately and seek medical care.
- If LLC gets on skin or clothing, wash with water immediately.
- LLC is flammable. Store in a location where flame is prohibited and it cannot be accessed by children.
- Engine coolant could leak if the radiator is not completely tightened or there is a gap in the seating face. Always be sure to securely tighten the radiator cap.
- Do not add engine coolant past the FULL level line of the coolant sub-tank.

(3) Coolant Capacity

Total Coolant Capacity
1.1 (0.16) gal.

Value in parenthesis is the sub-tank capacity.

8-3. Checking the Fuel



CAUTION : FIRE



- This generator uses diesel fuel. Always be sure to stop the engine and not bring flames close when inspecting fuel or refueling. Wait until the engine has cooled before inspecting or refueling.
- If fuel spills, always be sure to open the spill containment drain valve and drain off the spilled fuel.
(Refer to section “10. Inspection/Maintenance (9) Flushing Liquid in Spill Containment”.)
- Do not carry flammable items (such as fuel, gas and paint) or items that are highly combustible near the generator as the muffler, exhaust gas and other parts become extremely hot.
- Position this generator 3 ft. (1 m) or more from walls or other hindrances, and on a firm and level surface.
- Always be sure to wipe up any spilled fuel or oil before starting the engine.

Check if there is a sufficient amount of fuel and add fuel if insufficient.

The fuel meter on the control panel will only display the fuel level for the internal fuel tank. Be sure to close the cap tightly after refueling.

< Note >

- Use Diesel fuel, ASTM D975 No. 2-D, S15. Engine is designed to operate on Ultra Low Sulfur Diesel Fuel only. Use of any other fuel may result in engine no longer operating in compliance with emissions requirements.
- Use Diesel fuel, ASTM D975 No. 1-D, S15 for ambient Temperatures below 14 °F (-10 °C).
- The fuel supply pump, injectors and other parts of the fuel system and engine can be damaged if any fuel or fuel additives are used other than those specifically recommended by the engine manufacturer.

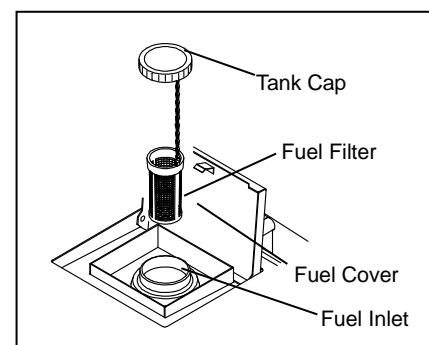

- Always be sure to use the fuel filter attached to the fuel inlet.
- Carefully add fuel until the tank is full.
- Do not mix gasoline or alcohol with diesel fuel. The mixture can cause a fire and damage engine components.
- Do not tilt or move the generator while it is running since this can cause fuel spillage.

8-4. Checking the Spill Containment



- If fuel or oil is leaking, repair the leaking location before operating.

Open the access door and check the inside of the spill containment. Flush out any accumulated liquid. Refer to section “10. Inspection/Maintenance (9) Flushing Liquid in Spill Containment” for flushing procedures.

< Note >

- The types of liquids that can accumulate in the spill containment include oil, fuel, coolant and battery fluid such that it is not possible to distinguish between rain water and other liquids. Dispose of flushed liquids according to the related laws and regulations.

8-5. Checking for Fuel, Oil and Coolant Leak



- If fuel or oil is leaking, repair the leaking location before operating.

Open the side door and check for fuel, oil and coolant leakage from fuel piping connections and similar locations.

8-6. Checking the Battery

California Proposition 65



Batteries, battery posts, terminals and related accessories contain lead and lead compounds, and other chemicals known to the State of California to cause cancer and birth defects or other reproductive harm. WASH HANDS AFTER HANDLING.



- Wear rubber gloves and other protective wear to protect eyes, skin and clothing from the battery fluid which contains diluted sulfuric acid. If the battery fluid contacts eyes or skin, wash out immediately with a large amount of water. Be sure to receive medical treatment, especially if the fluid contacts the eyes.



- Never use or recharge the battery if the fluid level is below the minimum level.
- Do not create sparks or bring flame near the battery as it generates flammable gas.

- 1 Check the fluid level, and add distilled water to the upper level when it is near the lower level.
- 2 Check the terminals for looseness and tighten if it is too loose.

< Note >

- It is necessary to recharge the battery when the specific gravity of the battery fluid is 1.23 or less. Request KUBOTA distributors and dealers to recharge the battery.

■ Replacing the Battery

- 1 Remove the battery negative (-) cable.
(Always be sure to remove the negative (-) side first.)
- 2 Remove the battery hold-down clamp.
- 3 Remove the battery positive (+) cable.
- 4 Remove the battery.

* Reverse the procedure above for installing the battery.
(First, connect the positive (+) cable of the replaced battery.)

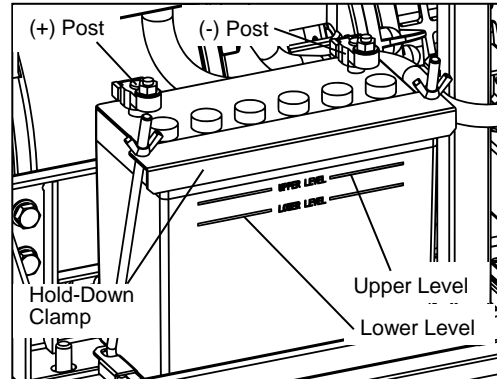

9. Operating Procedures

9-1. Initial Startup/Pre-Check

⚠ WARNING : EXHAUST GAS POISONING

- Do not operate the generator in poorly ventilated areas such as indoors or tunnels, as the exhaust gas of the engine contains substances that are harmful to human health.
- Do not direct exhaust fumes at bystanders or buildings.

⚠ WARNING : INJURY

- Always be sure to check that the breakers on load side and switches for any equipment using the generator are at OFF before turning the breaker to ON. Also be sure to advise personnel on the load side that power will be turned on before operating the breaker.
- Close all doors and lock them during operation.

⚠ CAUTION : FIRE 

- Do not carry flammable items (such as fuel, gas and paint) or items that are highly combustible near the generator as the muffler, exhaust gas and other parts become extremely hot.
- Position this generator 3 ft. (1 m) or more from walls or other hindrances, and on a firm and level surface.

⚠ CAUTION : INJURY

- Do not operate the generator if it has been modified or any parts have been removed.
- Position the generator on a level stable surface so that it cannot slide or move in any manner.
- Before starting operation, always be sure to turn off all switches of equipment being used and all breakers to OFF.

< Note >

- Check that the surrounding area is safe before starting the engine.
- When there are multiple workers who are working together, they must mutually signal each other before starting the engine.
- Do not use in an area with high temperature or humidity, or an area with a large amount of dust.
- Do not open access doors during operation. Operating with open doors can negatively affect cooling effect, resulting in an equipment malfunction.
- Use ear protections if the level of noise is high. Failure to do so could result in hearing damage.
- Please be careful in the opening and closing of the door. The door is opened and closed suddenly especially in strong winds and the sloping place, and your finger might get caught in a door.

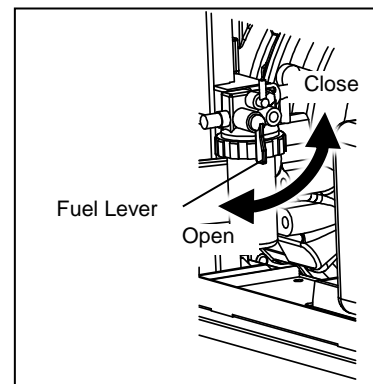
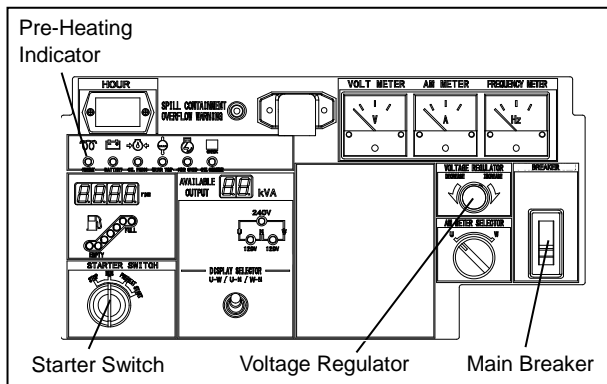

- 1 Turn the three-phase and single-phase breakers on the operation panel to OFF.
- 2 Turn the fuel lever to open.
- 3 If the temperature is 41°F (5°C) or less, turn the starter switch to PREHEAT and wait until the preheat lamp turns off (approximately 5 seconds).
- 4 When the pre-heating indicator changes from light up to off, immediately change the switch to START and start the engine.
- 5 After starting the engine, remove your hand from the starter switch.
- 6 Warm up the generator for 5 minutes.
- 7 Adjust the voltage regulator dial to the specified voltage.
- 8 Turn the breaker to ON to start AC power delivery.

< Note >

- Pre-heating time completes in approximately 5 seconds.
- Do not continuously operate the starter motor for 15 seconds or more.
- If repeating starter switch operation, wait 30 seconds or more between re-starting.
- Be aware that smoke might be generated when the engine is started.

9-2. Procedures during Operation

(1) Checks after Startup

- Make sure that all meters and indicators are in normal status. (Refer to section “5. Equipment”.)
- Check that there is no abnormal vibration or noise.
- Check that the exhaust gas color is normal. When operation is normal, the exhaust gas should be colorless or slightly bluish.

< Note >

- In the event of abnormalities, stop using this generator and request KUBOTA distributors and dealers to repair the generator.

(2) Adjustment during Operation

During load operation, check the voltmeter and finely adjust voltage using the voltage regulator dial.

■ Restarting after stopping due to running out of fuel

The fuel filter includes an automatic air-bleeding device. Restart the engine easily according to the following procedures even if the engine has stopped due to running out of fuel.

- 1 Turn the three-phase and single-phase breakers in the operation panel to OFF position.
- 2 Turn the starter switch to STOP.
- 3 Add fuel to the fuel tank.
- 4 Turn the starter switch to START and crank the starter motor for approximately 10 seconds.
- 5 After the engine starts, remove your hand from the starter switch.
- 6 Wait for air to be completely bled from the fuel pipes and engine speed to stabilize (approximately 1 minute).

* The engine speed is not stable until air is bled from the fuel pipes completely.

< Note >

- Do not apply any loads until air-bleeding has been completed (until the engine speed becomes stable). Doing so can cause a malfunction.
- If repeating starter switch operation, wait 30 seconds or more between re-starting.

9-3. Stopping Operation



CAUTION : BURNS



- Do not touch the engine and surrounding components immediately after stopping the engine as they are still extremely hot.

- 1 Turn the switches and breakers on the load side to OFF.
- 2 Turn the main breaker on the operation panel to OFF.
- 3 The engine cools down for approximately 3 minutes.
- 4 Turn the starter switch to STOP.
- 5 After the engine stops, turn the fuel lever to CLOSE.

9-4. Protective Functions

⚠ WARNING : INJURY 

- Do not open the access door during operation. Avoid moving parts such as the cooling fan and fan belt.
- Always be sure to stop the engine and remove the starter key when performing inspection or maintenance.

⚠ CAUTION : BURNS 

- Do not touch the engine and surrounding components immediately after stopping the engine as they are still extremely hot.
- Hot steam gushes out from the coolant sub-tank if the generator overheats. Do not touch the coolant sub-tank.

This generator is equipped with functions to automatically stop operation when there is a fault/malfunction during operation, and one to warn the operator of the fault location by use of indicator lamps. Check the fault location when the engine is automatically stopped or an indicator lamp illuminates to stop the engine.

Protection Feature List

No.	Action		Main Breaker Trip	Engine Automatic Shutdown	Warning Lamp Flash	Cause
	Abnormality					
1	Monitor Lamp	High Water Temperature	–	○	○	Activates due to high water temperature in the engine Default 239°F (115°C)
2		Low Oil Pressure	–	○	○	Activate due to low oil pressure in the engine Default 14 psi (0.98 × 100 kPa)
3		Insufficient Battery Charge	–	○	○	Activates in battery charge Impossible
4		Engine Overspeed	–	○	○	Engine speed is too fast (4,140 rpm or more)
5		Spill Containment Fluid Level Overflow	–	–	○	Spill containment accumulated fluid has exceeded the specified level making it necessary to flush the fluid.
6	Spill Containment Fluid Overflow		–	○	○	Spill containment accumulated fluid has exceeded the specified level making it near the fill.
7	Overload		○	–	–	Activates in overload
8	Terminal Cover Open		○	○	–	Activates when terminal cover is opened.

* ○ indicates the automatic activation.

10. Inspection/Maintenance

California Proposition 65

WARNING

Batteries, battery posts, terminals and related accessories contain lead and lead compounds, and other chemicals known to the State of California to cause cancer and birth defects or other reproductive harm. WASH HANDS AFTER HANDLING.

WARNING : ELECTRIC SHOCK/INJURY

- Do not touch output terminals or internal electric parts while the generator is operating.
- Do not open the access door during operation. Avoid moving parts such as the cooling fan and fan belt.
- Always be sure to stop the engine and remove the starter key when performing inspection or maintenance.
- Do not lift up using tie downs. Use of such could result in the generator falling.
- No persons should be under a suspended generator at any time.

CAUTION : FIRE

- Always be sure to wipe up any spilled fuel or oil before starting the engine.

CAUTION : BURNS

- Do not touch the engine and surrounding components immediately after stopping the engine as they are still extremely hot.
- Do not open the radiator cap immediately after stopping the engine. Doing so will result in steam gushing out.
- Hot steam gushes out from the coolant sub-tank if the generator overheats. Do not touch the coolant sub-tank.

CAUTION : INJURY

- Personnel performing suspension work must wear protective gear such as helmets, safety shoes and gloves.
- Always be sure to use lifting hooks when suspending the generator, and raise it slowly at a completely vertical angle.

Perform periodic inspection and maintenance according to the following table in order to constantly maintain this generator in good working condition. Use the hour meter as a reference for the operating time.

< Note >

- All procedures except for pre-operation inspection should be performed by specialized technicians.
- Request KUBOTA distributors and dealers to perform the procedures in the table with a “●”.
- Always be sure to use genuine parts or those indicated specifically for replacement parts.
- Use a container to catch fluid bled from this generator that is large enough to prevent the fluid from spilling on the ground.

Dispose of oil, fuel, coolant (LLC), filter, battery and other hazardous materials according to laws and regulations concerning industrial waste.

Contact KUBOTA distributors and dealers if you have any inquiries regarding proper disposal.

- When access doors are open during maintenance, take measures so that unrelated personnel cannot accidentally come close to the generator. Close all doors and covers if you are going to be away from this generator.
- Please be careful in the opening and closing of the door. The door is opened and closed suddenly especially in strong winds and the sloping place, and your finger might get caught in a door.
- The items listed above (@ marked) are registered as emission related critical parts by KUBOTA in the U.S. EPA non-road emission regulation. As the engine owner, you are responsible for the performing of the required maintenance on the engine according to the above instruction. Please see the Warranty Statement in detail.

Inspection Item	Pre-Operation Inspection	Inspection Intervals						Ref page	
		50 th hour	Every 100 hours	Every 200 hours	Every 400 hours	Every 1,000 hours	Every 2,000 hours		
Inspect/Add Fuel	○							—	
Inspect/Add Engine Oil	○							—	
Change Engine Oil		1st time ○	2nd time and after ○					31	
Change Oil Filter		1st time ○		2nd time and after ○				32	
Inspect/Add Coolant	○							—	
Change Coolant						○ or 2 years		33	
Inspect fuel hoses and clamp bands		○						—	@
Inspect radiator hoses and clamp bands				○				—	
Clean Fuel Filter		1st time ○	2nd time and after ○					—	
Inspect intake air hose				○				—	@
Change intake air hose							● or 2 years (Replace)	—	@
Replace Fuel Filter Element					○			33	@
Drain Water from Fuel Tank				○				33	
Inspect for Fuel/Oil/Coolant Leakage	○							—	
Inspect/Add Battery Fluid	○							—	
Clean Air Filter Element		1st time ○	2nd time and after ○					32	@
Replace Air Filter Element					○ or 1 year			32	@
Drain Liquid from Spill Containment	○							35	
Adjust Fan belt Tension		1st time ○	2nd time and after ○					34	
Replace Fan belt					● or 2 years			—	

Inspection Item	Pre-Operation Inspection	Inspection Intervals						Ref page	
		50 th hour	Every 100 hours	Every 200 hours	Every 400 hours	Every 1,000 hours	Every 2,000 hours		
Engine	Replace fuel hoses and clamp bands						● or 2 years	—	@
	Replace radiator hoses and clamp bands						● or 2 years	—	
	Clean Radiator Fin (External)				●			—	
	Clean Radiator (Internal)				●			—	
	Replace Oil Hoses and Anti-Vibration Rubber				○ or 1 year (Check)		● or 2 years (Replace)	—	
	Adjust/Lap Clearance of Air Intake/Release Valves					● Adjust- ment	● Lapping	—	
	Inspect/Adjust Clearance of Fuel Injection Valves				●			—	@
	Inspect/Adjust Fuel Injection Pump						●	—	@
	Inspect damage in electric Wiring and loose connections				○ or 1 year			—	
	Clean/Inspect Spill Containment				● or 1 year			35	
	Elimination of carbon in the exhaust system				○			37	
Generator	Indicators, Gauges Alarms (Check)	○						—	
	Insulation test			●				—	

(1) Engine Oil Replacement

First Time	50 th hour
Thereafter	Every 100 hours

- 1 Set a container to catch spilled engine oil.
- 2 Remove the oil filler cap.
- 3 After removing the oil drain plug, drain the engine oil.
- 4 After the oil has been drained, close and tighten the oil drain plug.
- 5 Add oil through the oil filler until it is at the maximum level while checking the oil level using the oil level indicator.
- 6 Attach the oil filler cap.

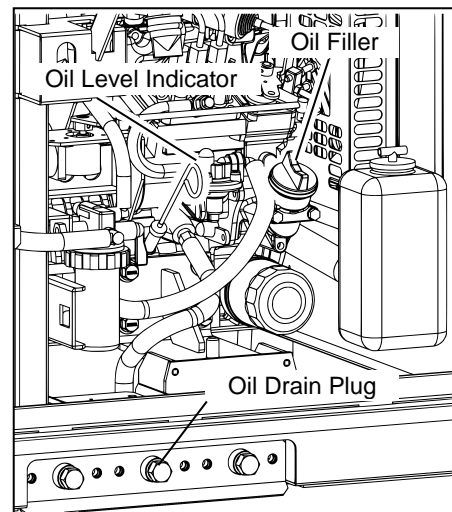

< Note >

- Refer to section “8-1. Checking Engine Oil” for engine oil replacement amounts and types.
- After tightening the oil drain plug and shortly after starting the engine, be sure to always check that there is no oil leakage.

- Always be sure to wipe up any spilled engine oil before starting the engine.
- Replace the packing of the oil drain plug with a new part each time the oil is changed.

(2) Replacing the Oil Filter

First Time	50 th hour
Thereafter	Every 200 hours

- 1 Drain the engine oil. (Refer to section “(1) Engine Oil Replacement”.)
- 2 Remove the oil filter using a filter wrench.
- 3 Apply thin layer of oil on a new oil filter gasket.
- 4 Screw the oil filter by hand and securely tighten by hand (do not use a filter wrench) after the gasket contacts the seal surface.
- 5 Add engine oil to the generator.
- 6 Shortly after starting the engine, always be sure to check that there is no oil leakage from the seal surface.

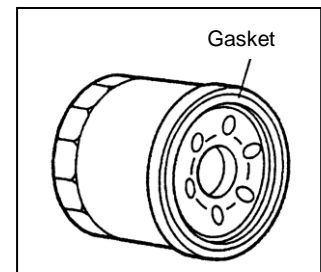
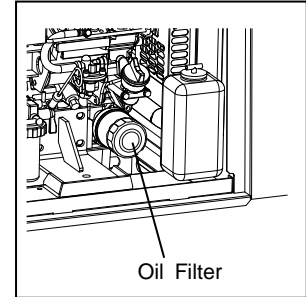

< Note >

- Request KUBOTA distributors and dealers to perform this procedure if you do not have a filter wrench.
- Always be sure to wipe up any spilled engine oil before starting the engine.

(3) Air Filter Element Cleaning/Replacement

Clean	1st Time: 50 th hour 2nd Time and after: Every 100 hours
Replace	Every 400 hours

- 1 Remove the air cleaner clips and cleaner cap.
- 2 Remove the element.
- 3 Clean or replace the element. Reverse the procedure above for re-assembly.

< Note >

- Always be sure to put the cleaner cap in the upward of the arrow direction.
- Replace the elements earlier if using in an excessively dusty location.
- Do not add oil as this generator uses a dry element.
- Clear foreign material by pinching the evacuator valve once a week in normal operating conditions or daily if operating in a location that is excessively dirty or dusty. Wipe away any dirt or moisture that has adhered to the parts.
- Never touch the elements for any reason except cleaning.

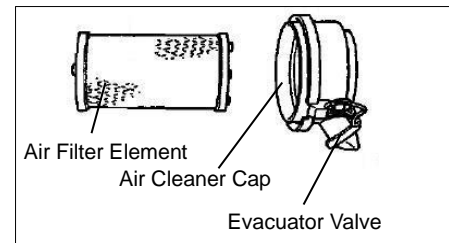
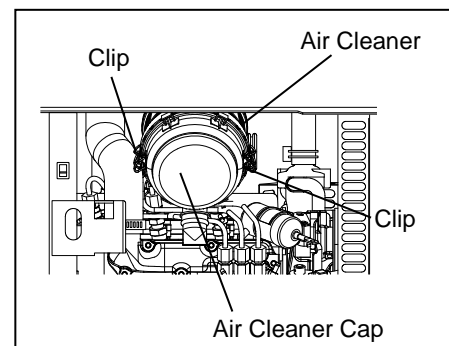

■ Cleaning the air filter element

If dry dust is adhering: Blow compressed air from inside the element.

If carbon or oil is adhering : Replace with new parts.

(4) Fuel Filter Element Replacement

Clean	1st Time: 50 th hour 2nd Time and after: Every 100 hours
Replace	Every 400 hours

- 1 Turn the fuel lever to CLOSE.
- 2 Turn the retainer ring to the left and remove the cup and element.
- 3 Remove any water or foreign material from the cup and clean the element using compressed air (or replace the element).
- 4 Reverse the procedure above for re-assembly.

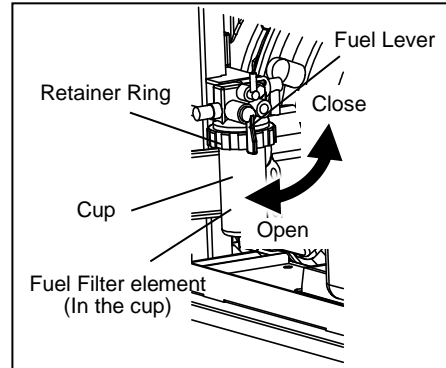

< Note >

- Check that no foreign material is adhering to the packing then install the cup.
- After installation, turn the fuel lever to OPEN and check that there is no fuel leakage. After checking, turn the fuel lever to CLOSE.
- Always be sure to wipe up any spilled fuel before starting the engine.
- If water gathers in the cup, drain water from the fuel tank. (Refer to section “10, Inspection/Maintenance (5) Draining Water from the Fuel Tank)

(5) Draining Water from the Fuel Tank

Drain Water	Every 200 hours
-------------	-----------------

- 1 Set a container to catch spilled water.
- 2 Remove the fuel drain plug and packing.
- 3 After the water has been drained, tighten the fuel drain plug with new packing.

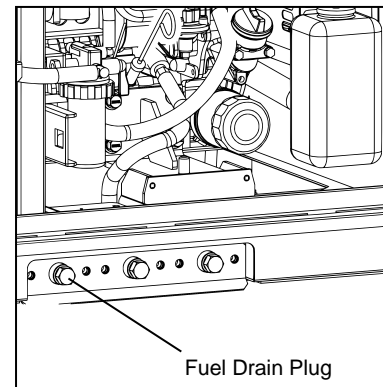

< Note >

- Replace the packing of the fuel drain plug with new packing each time the water is drained.
- After tightening the fuel drain plug, be sure to always check that there is no fuel leakage.

(6) Coolant Replacement

Replace	Every 1,000 hours or 2 years
---------	------------------------------

- 1 Open the top plate.
- 2 Remove the radiator cap.
- 3 Remove the coolant drain plug and packing
- 4 After the water has been drained, tighten the water drain plug with new packing.
- 5 Remove the sub-tank and flush the coolant from the sub-tank.

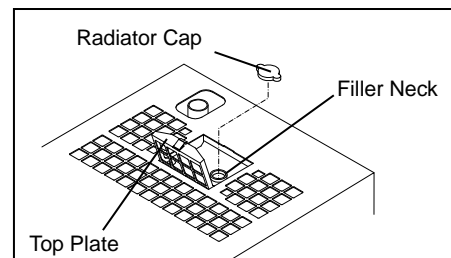

- 6 Re-attach the sub-tank to its original position and fill with coolant until it reaches the full level.
- 7 Fill the radiator with coolant until it reaches the filler neck.
- 8 Re-attach and tighten the radiator cap.
- 9 Close the top plate.

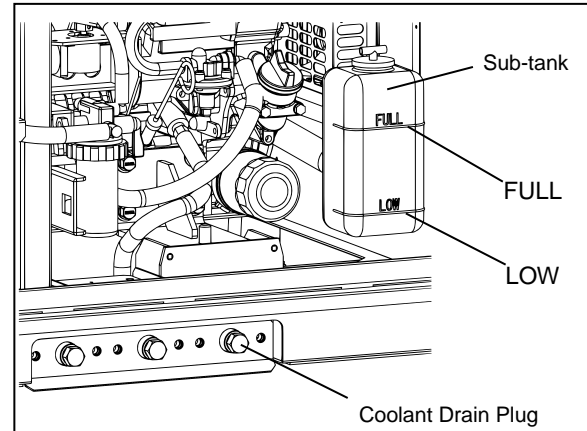

< Note >

- Replace the packing of the water drain plug with new packing each time the coolant is drained.
- After tightening the water drain plug, operate the engine for a start period and be sure to always check that there is no coolant leakage.
- Refer to section “8-2. Checking Coolant” for the type of coolant.

(7) Fan Belt Adjustment

First Time	50 th hour
Thereafter	Every 100 hours

- 1 Remove the safety guard.
- 2 Inspect that there is no damage to the fan belt. If so, be sure to replace it.
- 3 Push the center of the fan belt with your finger (49N “5kg·f”), check the slack is about 0.39 in (10mm). If the belt tension is too loose, adjust the alternator position by unscrewing two bolts that hold the alternator.
- 4 Reverse the procedure above for re-assembly.

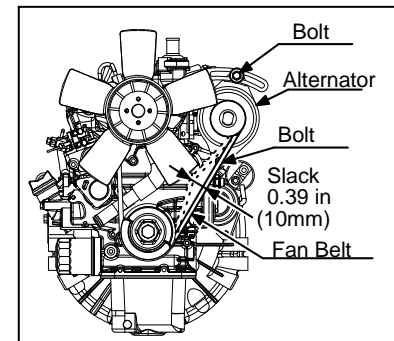
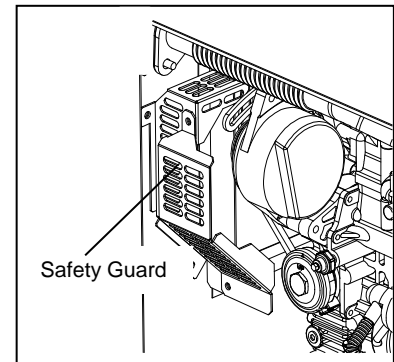

< Note >

- Be sure to tighten the bolt after adjusting the alternator.
- Contact your local Authorized KUBOTA Engine America generator distributor or dealer to replace the fan belt.

(8) Rubber Hose and Anti-Vibration Rubber Inspection/Replacement

Inspect	Every 50 hours
Replace	2 years or every 2,000 hours

< Note >

- If the rubber hoses (such as oil, coolant, air and drain) have been hardened or deteriorated, replace them with new ones.
- Contact your local Authorized KUBOTA Engine America generator distributor or dealer to replace the rubber hose and anti-vibration rubber.

(9) Flushing Liquid in Spill Containment

Check	Daily
-------	-------

- 1 Set a container to collect liquid from the flushing port of the drain valve.
- 2 Remove the drain valve plug (R1/2) and open the valve lever.

< Note >

- When removing or attaching the plug, hold the drain valve fixed using a spanner or similar tool and turn the plug.
- If oil or other liquid is mixed in with the flushed liquid, this indicates that there is an oil leak. In such case, check the leak point.
- The types of liquids that can accumulate in the spill containment include oil, fuel, and coolant water and battery fluid such that it is not possible to distinguish between rain water and other liquids. Dispose of flushed liquids according to the related laws and regulations.

- 3 Close the drain valve lever after the liquid has been flushed and apply sealant coating to the plug or wrap it with seal tape.

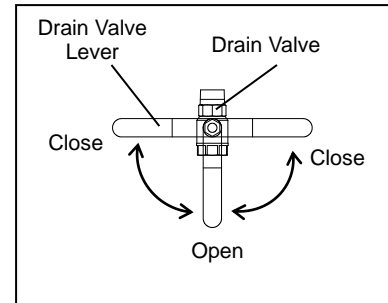
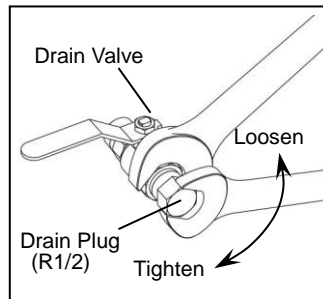
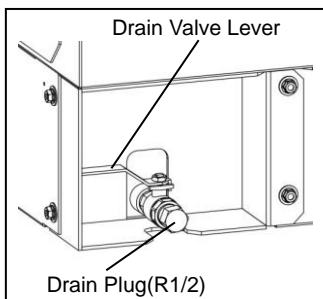

(10) Spill Containment Cleaning/Inspection



WARNING : INJURY



- Do not lift up the unit using tie downs. Use of such could result in the generator falling.
- No persons should be under a lifted generator at any time.



CAUTION : INJURY

- Always be sure to use lifting hooks when lifting up the generator, and raise it slowly at a completely vertical angle.
- Personnel performing lifting work must wear protective gear such as helmets, safety shoes and gloves.
- Do not move the generator during operation.

Clean	Every 400 hours or 1 year
-------	---------------------------

Separate the spill containment from this generator to clean and inspect the spill containment.

■ Spill Containment Separate/Reassemble

- 1 Remove the wiring connector.
- 2 Remove the seven spill containment fixing bolts (M8, 7 pieces).
- 3 Lift the generator, separate the spill containment and set the generator on a flat surface.
- 4 After cleaning and inspecting the inside of the spill containment, reverse the procedure above for re-assembly.
- 5 Reassemble the fuel piping and wiring connector to their original positions.

< Note >

- Do not operate the generator while separating.

■ Spill Containment Cleaning/Inspection

- 1 Use a high-pressure cleaner or similar equipment to clean the inside of the spill containment.
- 2 Remove the drain plug (R1/2) to drain the cleaning water and open the drain valve lever.
- 3 Check that no rust has developed inside of the spill containment. If rust has developed, remove the rust and clean again.
- 4 Close the drain valve lever.
- 5 Allow water to accumulate and check that the spill containment has no internal leakage.
- 6 Open the drain valve lever to drain the water.
- 7 After the procedures have been completed, close the drain valve lever and apply the sealant coating to the plug (R1/2) or wrap it by seal tape and tighten it.

< Note >

- If the fluid drained when cleaning the spill containment contains oil or grease, dispose of it according to the related laws and regulations.
- If the spill containment has a leak, contact your local Authorized KUBOTA Engine America generator distributor or dealer.

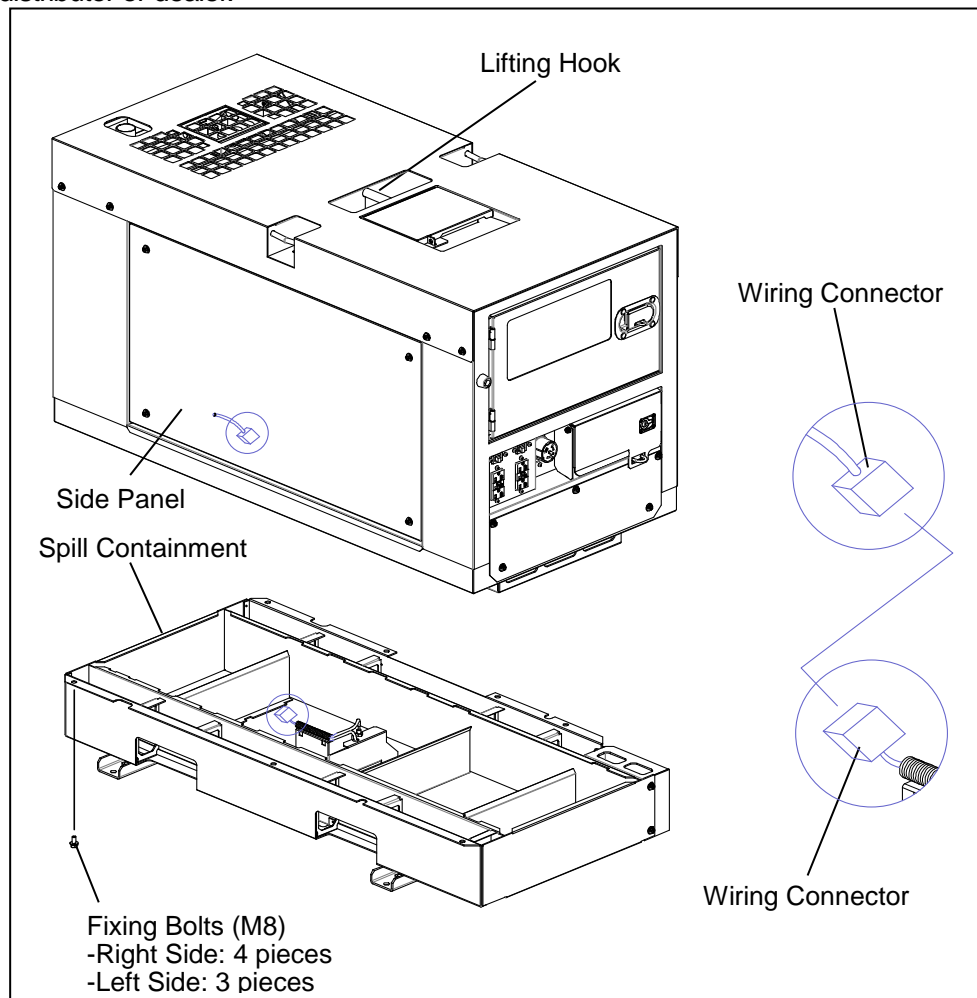

(11) Elimination of excessive carbon in the exhaust system by extensive light load

WARNING : EXHAUST GAS POISONING

- Do not operate the generator in poorly ventilated areas such as indoors or tunnels, as the exhaust gas of the engine contains substances that are harmful to human health.
- Do not direct exhaust fumes at bystanders or buildings.

WARNING : INJURY

- Always be sure to check that the breakers on load side and switches for any equipment using the generator are at OFF before turning the breaker to ON. Also be sure to advise personnel on the load side that power will be turned on before operating the breaker.
- Close all doors and lock them during operation.

CAUTION : FIRE

- Do not carry flammable items (such as fuel, gas and paint) or items that are highly combustible near the generator as the muffler, exhaust gas and other parts become extremely hot.
- Position this generator 3 ft. (1 m) or more from walls or other hindrances, and on a firm and level surface.

CAUTION : INJURY

- Do not operate the generator if it has been modified or any parts have been removed.
- Position the generator on a level stable surface so that it cannot slide or move in any manner.
- Before starting operation, always be sure to turn off all switches of equipment being used and all breakers to OFF.

Clean	Every 200 hours
-------	-----------------

Carbon will accumulated easier when the unit runs at less than 30% of rated output. Accumulation of carbon (soot, unburned fuel) in the exhaust system could cause a system decrease or an engine fault occurs. To eliminate soot and unburned fuel, run the unit at more than 70% of the rated output for about half an hour, until the exhaust gas become mostly colorless.

< Note >

- When the unit runs at rated power suddenly, accumulation of carbon in the exhaust system might cause a back fire. Operate the generator starting from 50% of the rated output and then increase load gradually after confirming exhaust gas has become colorless. Do not carry flammable items that are highly combustible near the generator.

(12) Fuse Replacement

CAUTION : FIRE

- Check to see if electric cable and wiring are swollen, hardened or cracked.
- Keep dust and water away from all power connections.
Loose wiring and Terminal parts make bad connections, be sure to repair them before starting the engine.

The electrical system is protected from potential damage by fuses.

A blown fuse indicates that there is an overload or a short circuit somewhere in the electrical system. If any of the fuses should blow, replace with a new one of the same one or equivalent.

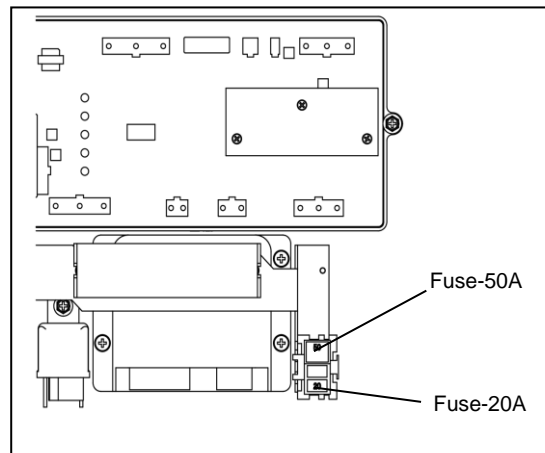

< Note >

- Before replacing a blown fuse, set the position of starter switch to OFF.
- Before replacing a blown fuse, determine why the fuse blew and make any necessary repairs. Failure to follow this procedure may result in serious damage to the generator electrical system. Refer to the troubleshooting section of this manual or your local Authorized KUBOTA Engine America generator distributor or dealer for specific information.

11. Long-Term Storage

WARNING : INJURY

- Always be sure to stop the engine and remove the starter key when performing inspection or maintenance.

CAUTION : FIRE

- Always be sure to wipe up any spilled fuel or oil before starting the engine.
- Allow the generator to cool before covering with the protective cover.

CAUTION : BURNS

- Do not touch the engine and surrounding components immediately after stopping the engine as they are still extremely hot.

(1) Storage Procedures

Perform the following maintenance procedures before storing this generator if it is not going to be used for two months or more.

- 1 Remove the battery. (Refer to section “8-6. Checking the Battery”.)
- 2 Replace the engine oil.
(Refer to section “10. Inspection/Maintenance (1) Engine Oil Replacement”.)
- 3 Drain the fuel from the fuel tank and filter.
(Refer to section “10. Inspection/Maintenance (5) Draining Water from the Fuel Tank”.)
- 4 Clean up and inspect inside of the spill containment.
(Refer to section “10. Inspection/Maintenance (10) Spill Containment Cleaning/Inspection”.)
- 5 Remove the starter key and store in a secure location.
- 6 Clean up all generator components, and store in a dry and dust-free location. Also cover when storing so that rain cannot enter through the suction or exhaust ports.

< Note >

- Adjust the fluid of the removed battery to the appropriate level and recharge approximately every month.

(2) Double-Stacking Storage Procedures

WARNING : INJURY

Always be sure to observe the following items when double stacking this generator in a warehouse or similar location.

- Check that the hood of this generator is not dented, and that bolts are not loose or missing.
- Set in a location with a flat hard floor capable of withstanding the double-stacking weight.
- Always be sure to use lifting hooks when lifting this generator.
- Insert wood ties of the same size and that are wider than this generator between each generator, and set another generator on top of the ties.
- Never stack more than two levels, and do not set a generator on top that is larger in weight/size than that on the bottom.
- Do not operate the generator when it is double stacked.

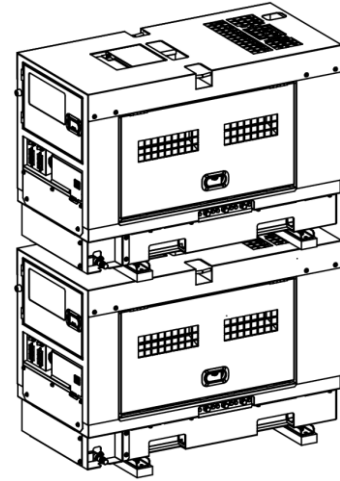

12. Troubleshooting

WARNING : ELECTRIC SHOCK/INJURY

- Do not touch output terminals or internal electric parts while the generator is operating.
- Do not open the access door during operation. Avoid moving parts such as the cooling fan and fan belt.
- Always be sure to stop the engine and remove the starter key when performing inspection or maintenance.

CAUTION : FIRE

- Never allow flame to come close to the generator.

CAUTION : BURNS

- Do not touch the engine and muffler after stopping the engine as they are still extremely hot.

Remove battery cable and set the position of starter switch to OFF , before inspecting this generator when operation is poor to determine the fault/malfunction.

Request your local Authorized KUBOTA Engine America generator distributor or dealer to perform maintenance if you cannot find any faults/malfunctions during inspection.

	Problem	Suspected cause	Action
Engine does not start	Starter motor does not drive or speed is low	<ol style="list-style-type: none"> 1. Battery output is weak 2. Battery is deteriorated 3. Battery terminal is OFF or loosen 4. Battery terminal is corroded 5. Starter switch or relay is defective 6. Starter motor is defective 	<ol style="list-style-type: none"> 1. Check battery fluid or charge 2. Replace Battery 3. Fix/Tighten terminal 4. Clean terminal 5. Contact distributor or dealer for repair 6. Contact distributor or dealer for repair
	Starter motor drives but engine does not start	<ol style="list-style-type: none"> 1. Fuel is insufficient 2. Fuel filter is clogged 3. Water is interfused in fuel line 4. Air is interfused in fuel line 5. Fuel lever is closed 	<ol style="list-style-type: none"> 1. Add fuel 2. Clean/Replace fuel filter 3. Drain water in fuel filter or fuel tank 4. Extract the air 5. Turn the fuel lever to OPEN
	<Ambient temperature falls down below 32°F (0°C) >	<ol style="list-style-type: none"> 1. Fuel is frozen 2. Water in fuel line is frozen 3. Pre-heater is defective 	<ol style="list-style-type: none"> 1. Use winterized fuel 2. Drain water in fuel line 3. Contact distributor or dealer for repair
Engine starts but stalls immediately	<ol style="list-style-type: none"> 1. Fuel filter is clogged 2. Water is interfused in fuel line 3. Air is interfused in fuel line 4. Air filter element is clogged 5. Lubricant oil is insufficient 6. Emergency operation/Fault detection 7. Terminal cover is opened 	<ol style="list-style-type: none"> 1. Clean/Replace fuel filter 2. Drain water in fuel filter or fuel tank 3. Extract the air 4. Check/Replace air filter element 5. Add lubricant oil 6. Contact distributor or dealer for repair 7. Close the terminal cover 	
Engine does not stop	<ol style="list-style-type: none"> 1. Stop solenoid fault 	<ol style="list-style-type: none"> 1. Turn the fuel lever to CLOSE to stop the engine and contact distributor or dealer for repair. 	
Engine oil pressure is low	<ol style="list-style-type: none"> 1. Lubricant oil is insufficient 2. Oil filter is clogged 3. Wrong oil is used 	<ol style="list-style-type: none"> 1. Add lubricant oil 2. Replace oil filter 3. Change to proper kind and viscosity oil 	
Overheated	<ol style="list-style-type: none"> 1. Engine thermostat is defective 2. Water temp sensor is defective 3. Fan belt tension is weak 4. Coolant is insufficient 5. Radiator core is clogged 	<ol style="list-style-type: none"> 1. Contact distributor or dealer for repair 2. Contact distributor or dealer for repair 3. Check/Adjust fan belt 4. Check/Add coolant 5. Clean radiator core 	
Black smoke comes out from Muffler	<ol style="list-style-type: none"> 1. Air filter element is clogged 2. Fuel injection nozzle is defective 3. Improper fuel is used 	<ol style="list-style-type: none"> 1. Check/Change air filter element 2. Contact distributor or dealer for repair 3. Change to clean fuel 	
White smoke comes out from Muffler	<ol style="list-style-type: none"> 1. Too much or too little oil to cylinder 2. Water is interfused in fuel line 3. Fuel injection nozzle is defective 4. Coolant temperature is too low 5. Engine thermostat is defective 	<ol style="list-style-type: none"> 1. Contact distributor or dealer for repair 2. Drain water in fuel filter or fuel tank 3. Contact distributor or dealer for repair 4. Warm-up driving is needed 5. Contact distributor or dealer for repair 	

Problem	Suspected cause	Action
Pointer (hand) does not move in voltage meter	<ol style="list-style-type: none"> 1. Voltage meter is defective 2. AVR is defective 3. Disconnected circuit, loose terminal or departed 4. Initial exciter is defective 5. Alternator is defective 	<ol style="list-style-type: none"> 1. Contact distributor or dealer for repair 2. Contact distributor or dealer for repair 3. Contact distributor or dealer for repair 4. Contact distributor or dealer for repair 5. Contact distributor or dealer for repair
Pointer (hand) does not goes up to the rated voltage	<ol style="list-style-type: none"> 1. Voltage meter is defective 2. AVR is defective 3. Voltage regulator dial is defective 	<ol style="list-style-type: none"> 1. Contact distributor or dealer for repair 2. Contact distributor or dealer for repair 3. Contact distributor or dealer for repair
Pointer exceeds the rated voltage	<ol style="list-style-type: none"> 1. Voltage meter is defective 2. AVR is defective 3. Improper load cable connection 	<ol style="list-style-type: none"> 1. Contact distributor or dealer for repair 2. Contact distributor or dealer for repair 3. Correctly set the connection location to the receptacle
The voltage drops drastically when connecting to load	<ol style="list-style-type: none"> 1. AVR is defective 2. Unbalanced loads sharing to each terminal 3. The current of the used equipment exceeds the rated current 4. Over load 5. Frequency is different 	<ol style="list-style-type: none"> 1. Contact distributor or dealer for repair 2. Balance the loads sharing to each terminal 3. Change to a device with an available capacity 4. Decrease the loads to meet the rated output 5. Set the specific frequency
Unable to turn the breaker to ON	<ol style="list-style-type: none"> 1. The Main breaker position is in between ON and OFF 2. Short circuit on the load 	<ol style="list-style-type: none"> 1. Once turning the lever to OFF, turn it to ON 2. Check the load circuit

13. Generator Circuit Diagram

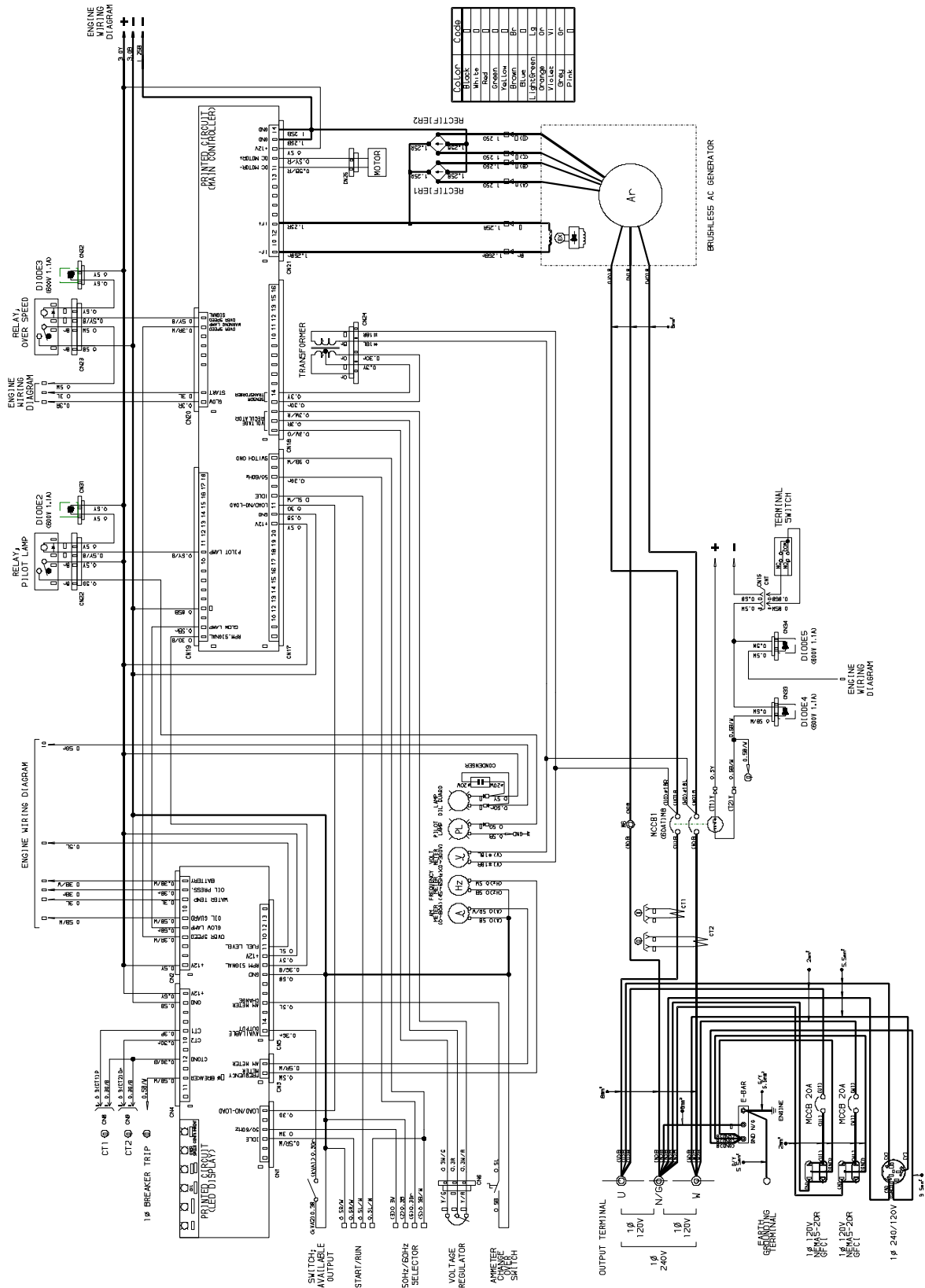

14. Engine Electrical Circuit Diagram

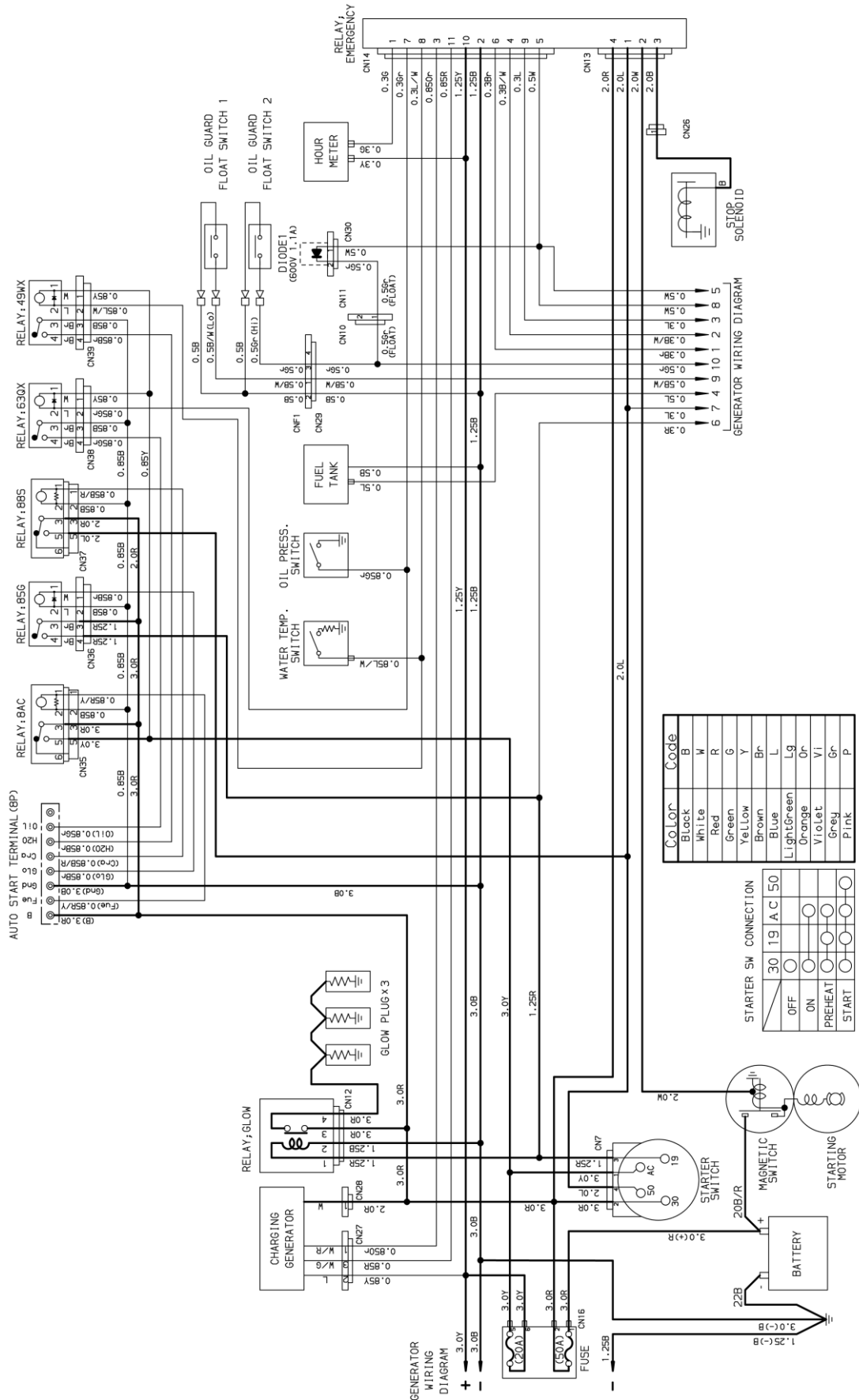

Color	Code
Black	B
White	W
Red	R
Green	G
Yellow	Y
Brown	Br
Blue	L
LightGreen	Lg
Orange	Or
Violet	Vi
Grey	Gr
Pink	P

STARTER SW CONNECTION	30	19	A C 50
OFF	○	○	○
ON	○	○	○
PREHEAT	○	○	○
START	○	○	○

Kubota

KUBOTA ENGINE AMERICA CORPORATION

505 Schelter Road

Lincolnshire, IL 60069

Phone: (847) 955-2500

Website: www.kubotaengine.com