

# FURNITURE FRONTS

---

*Bel Visa*<sup>®</sup>  

by viyar



## CONTENTS

---

The history of Bel Viso	2
Production	4
Advantages	5
<b>Veneered fronts</b>	<b>6</b>
<b>Painted fronts</b>	<b>14</b>
<b>Film fronts</b>	<b>58</b>
<b>HPL-fronts</b>	<b>88</b>
Fenix	90
Arpa	96
<b>Bel Viso Glass fronts</b>	<b>102</b>
<b>Acrylic fronts</b>	<b>112</b>
Crystal	114
Contacts	120

*Bel Viso*<sup>®</sup>

# BEL VISO

# HISTORY

---

What is Bel Viso? These are quality fronts and interior solutions for everyone. It is the desire to make any room stylish, cozy and full of love.

How did it all start? VIYAR has been supplying furniture components and materials since 2002. We spent a long time choosing fronts that would suit us by all criteria: perfect value for money, aesthetics, individual solutions and customer focus. That is why in 2014 we came up with the idea to create our own brand that would meet all these needs.

***«We watched the joy and admiration of people seeing their new home for the first time. A place full of beauty and love.***

***So we decided: we produce happiness»***

Bel Viso products are quality interior solutions for everyone. All samples of materials are collected in VIYAR showrooms, where you can touch them, compare and choose according to your needs. In the spring of 2021, the VIYAR opened its own factory for the production of Bel Viso fronts in Vasytkiv.

---





## THE HISTORY OF THE BRAND

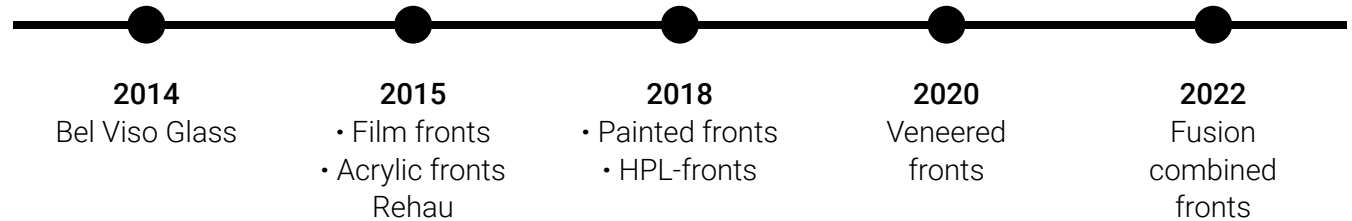

## BEL VISO IN NUMBERS



The total area of the factory reaches **over 10,000 m<sup>2</sup>**.



The Bel Viso factory has **over 100 units of professional equipment**.



VIYAR has produced **about 1 million m<sup>2</sup> of fronts** since the creation of the brand.



The factory's capacity is **60,000 m<sup>2</sup> of various types of fronts per month**.



Bel Viso offers **10 types of fronts and over 3,000 decor options**.

*Bel Viso*<sup>®</sup>

BEL VISO

# PRODUCTION

We produce about 25,000 m<sup>2</sup> of fronts per month. The own production allows full control over all stages of production – from procurement of raw materials to packaging of finished products.

## Production of fronts



### Top brand materials

- MDF Egger
- Italian paintwork materials Sayerlack and Voteller
  - Fenix / ARPA
  - Rehau
- Cortizo aluminum profile
  - Film made in Italy and Germany
- Natural veneer and modified veneer of the Italian brand ALPI



### Professional equipment

- CNC machines Homag / Biesse
  - BHX drilling machines
- Diamond tool for mechanical processing
  - Fanuc robotic arm for processing manipulations
- Cefla Finishing and others





BEL VISO

# ADVANTAGES

---

- **Different types of front coverings:** matte and glossy, monochrome decors and patterns, imitations of wood, stone and other materials.
- **Individual approach to each order.** We are always ready to implement non-standard solutions and implement the most creative ideas.
- **No minimum order.** We manufacture both large bulk orders and small orders from 1 m<sup>2</sup>.
- **Attention to details.** We offer a ready selection of milled and cut-in handles for fronts.
- **10-year warranty.** The use of the best materials and quality control at each stage of production are our main principles of work.
- **The minimum terms of production.** Thanks to established production processes, the estimated production time for film fronts is 6 days, for painted fronts – 10 days.
- **Express production.** Thanks to the express production service, customers can receive orders in just 24 hours.
- **High-quality packaging** that protects fronts from mechanical damage during transportation.
- **Ecological products.** In production, we use certified materials that are safe for people and the environment.

---

*Bel Viso*<sup>®</sup>

# VENEERED FRONTS

---

## TOUCH THE UNIQUE NATURE PATTERNS

Bel Viso veneered fronts are covered with a thin layer of natural or modified veneer (0.5 mm thick) based on MDF. The main advantages are the natural texture and environmental friendliness of wood.

### We use two types of veneer:

- **Natural veneer** – a wood slice on which the natural texture is completely preserved. Manufacturer – «Euroshpon», Ukraine.
- **Modified veneer** is made using fine-line technology, which makes it possible to create a stable structure and shade. Manufacturer – ALPI, Italy.

Veneer should be covered with paints and varnishes, which guarantees protection from moisture, dyes, UV light, and also allows you to give the wood any shade. Types of coating: paint (RAL and NCS catalogs), stain, matte and semi-matte varnishes Sayerlack. Modified veneer is covered only with varnishes. The range of veneered fronts includes more than 80 decors.

**Bel Viso**<sup>®</sup>

---





## ADDITIONAL SERVICES

---

Double-sided coating 

Coating with paints  
and varnishes 

Eco (natural material) 

Gluing of a slice at 45° 

Preservation of wood texture 

Painting the sample 





# FRONTS

# veneered

---

## MATERIALS FROM VISUALIZATION:

- Milling: Nero 100
- Base: Chipboard Egger U 775 ST9 White-grey
- Fronts: Lamel Oak, MDF Painted matte NCS S 1000-N
- Countertop ARPA 0001 CLIFF 40 mm /art. 147631
- Handle Marella CL 24316.35 nickel polished | black matte /art. 69018

*Bel Visa*<sup>®</sup>

# NERO 100 MILLING

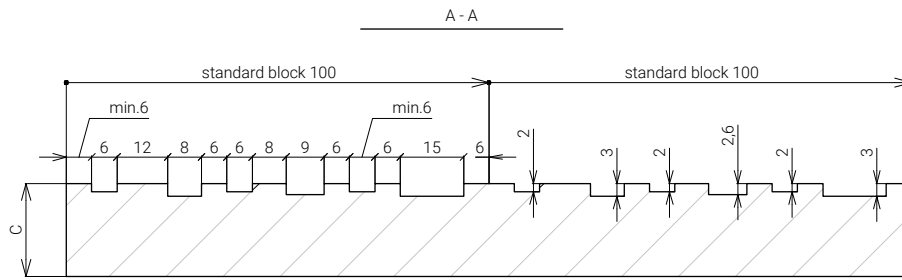

# EMMY 32 MILLING

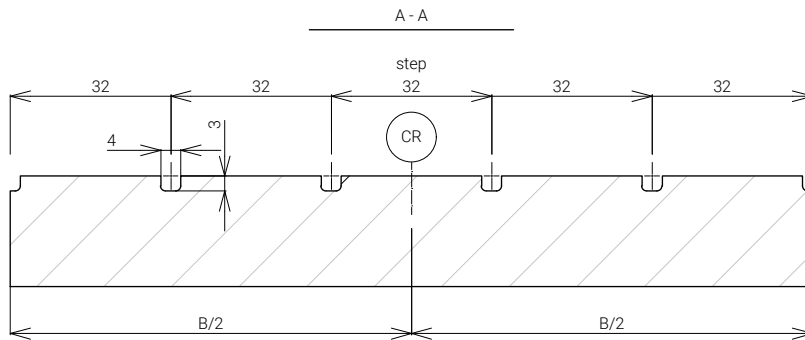

# WAVE 17 MILLING

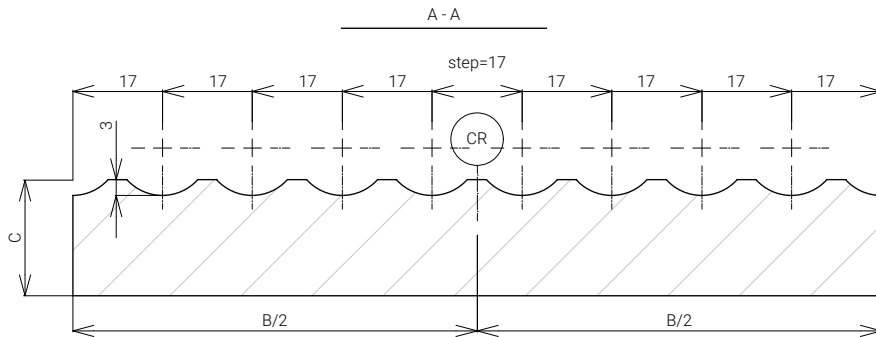
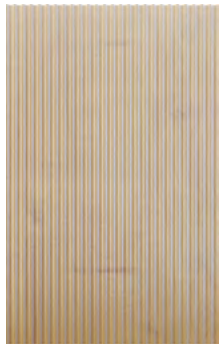



# FRONTS

# veneered

---

## MATERIALS FROM VISUALIZATION:

- Color: Classic oak tangential
- Handle VV 808/224, black, Turkey /art. 125791
- Countertop ARPA 3329 MIKA moisture resistant /art. 18278

*Bel Visa*<sup>®</sup>

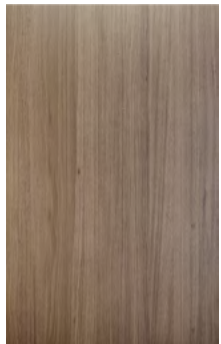

Veneer Classic oak  
radial

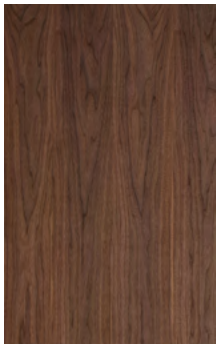

Veneer American walnut  
tangential

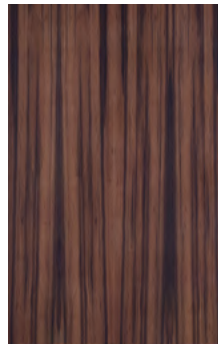

Veneer Amber tree  
moraine ALPI



Veneer White oak  
18.50 ALPI

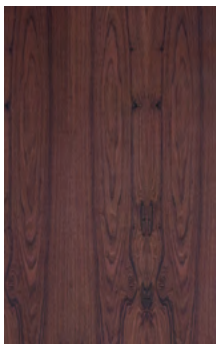

Veneer Lauro Preto  
ALPI



Veneer Smoky gray oak  
10.65 ALPI





# FRONTS VENEERED



Veneer European oak  
Rough Cut 3D ALPI



Veneer Walnut XILO  
tangential 10.11 ALPI



Veneer Sukupira  
ALPI



Veneer Wood Contur  
Classic oak tangential



Veneer American aged  
walnut ALPI



Veneer Planked oak  
12.96 ALPI



Veneer American wavy  
walnut 12.19 ALPI



Veneer Gray oak  
18.23 ALPI

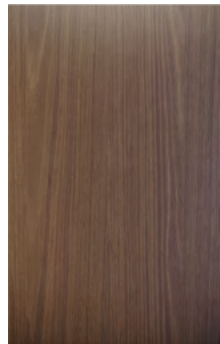

Veneer Volsky walnut  
10.95 ALPI



Veneer Smoky oak  
12.85 ALPI



Veneer Noble walnut  
ALPI



Veneer Rosewood  
ALPI



# PAINTED FRONTS

---

## INFINITY OF CHOICE

Painted fronts Bel Viso are an opportunity to choose any color and not limit yourself. More than 2500 colors with the service of painting the sample (versions from the RAL, WCP, NCS catalogs), various coatings, milling, decorative elements, milled handles. And to give them a refined antique look, you can apply 7 colors of patina. Painted fronts are practical in operation, resistant to moisture and high temperatures.

At the heart – MDF board from the Austrian manufacturer Egger, covered with Italian paints Sayerlack. We also use acrylic varnishes that don't burn out over time. Production of painted fronts Bel Viso is fully automated, so the occurrence of shortages is minimized.

*Bel Viso*<sup>®</sup>

---







## ADDITIONAL SERVICES

---

Milled handle 

Window case 

Double-sided coating 

Patina 

Coating with paints  
and varnishes 

Painting the sample 

Restoration kit 

Express production  
of smooth fronts 

Individual milling 



# FRONTS

# ASSEMBLED

# PAINTED

---

## MATERIALS FROM VISUALIZATION:

- Color: RAL 9003
- Milling: Model 1
- Handle Marella M 15232.128 polished nickel /art. 83723
- Handle Marella M 24232.30 polished nickel /art. 83725
- Countertop Quartzite Caesarstone 5141 Frosty Carrina 20 mm



*Bel Viso*<sup>®</sup>

## MODEL 1 MILLING

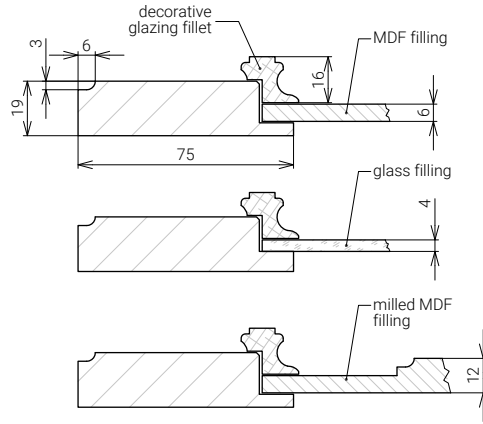

## MODEL 2 MILLING

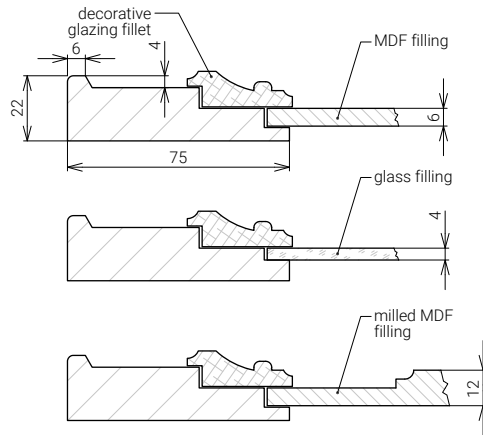

## MODEL 3 MILLING

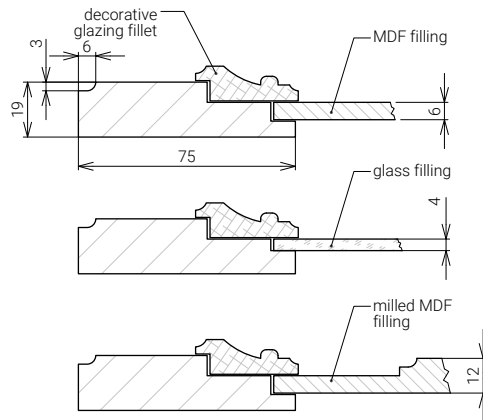

# FRONTS PAINTED

## Variety of lines collection

### MATERIALS FROM VISUALIZATION:

- Color: VMA0307310
- Milling: Nevis 19
- Countertop Sintered Stone Inalco Azalai Negro natural 12 mm
- Backsplash: Sintered Stone Inalco Azalai Negro natural 4 mm



*Bel Viso*<sup>®</sup>

## EMMY 32 MILLING

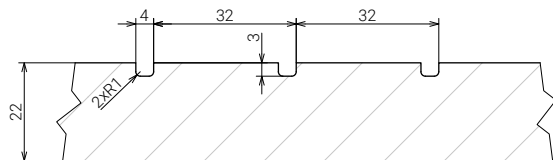

## KOS 21 MILLING

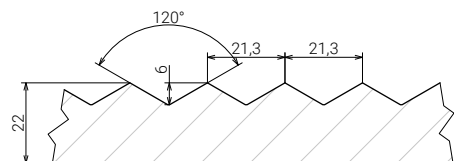

## NEVIS 19 MILLING

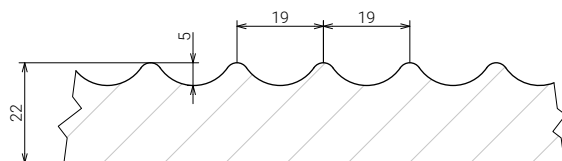

## SUNSET 15 MILLING

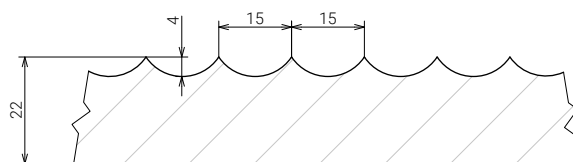

## FANCY 24 MILLING

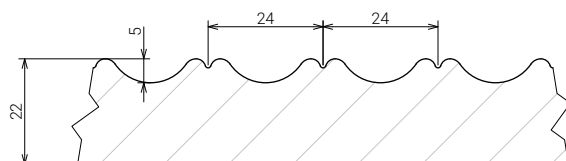

# FRONTS PAINTED

## Variety of lines collection

### MATERIALS FROM VISUALIZATION:

- Color: RAL 9016
- Milling: Aster
- Handle RE 1006/320 (DR 10/320 G5) Nickel /art. 80804
- Handle RE 1006/160 (DR 10/160 G5) Nickel /art. 80800
- Countertop Veneer Oak tangental 38 mm
- Backsplash: Sintered Stone Inalco Iseo Gris abujardado 4 mm



*Bel Viso*<sup>®</sup>

## ASTER 130 MILLING

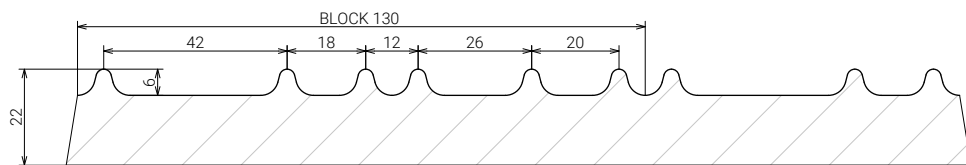

## NEVIS 24 MILLING

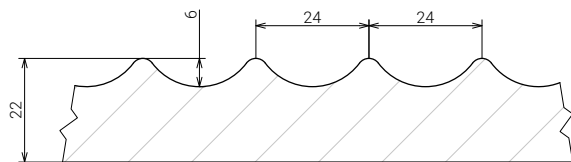

## SUNSET 20 MILLING

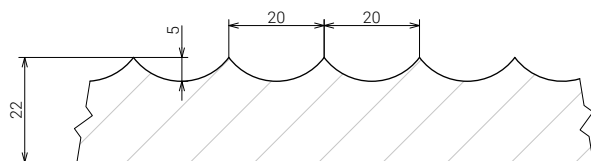

## FANCY 29 MILLING

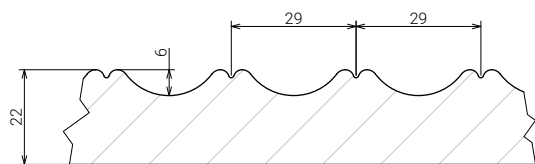

## NEVIS 28 MILLING

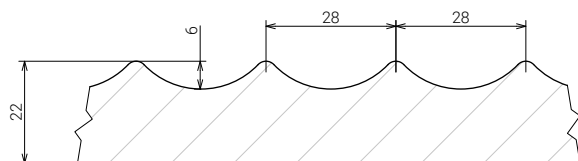



# FRONTS PAINTED

## Variety of lines collection

### MATERIALS FROM VISUALIZATION:

- Color: NCS 1515-R20B
- Milling: Airy
- Countertop Acrylic Getacore GC 4410 Concrete Riva

*Bel Viso*<sup>®</sup>

## SUNSET 24 MILLING

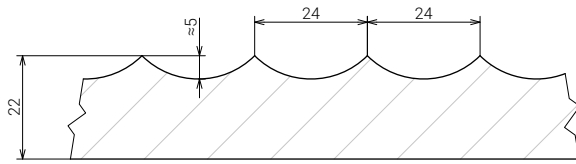

## FANCY 33 MILLING

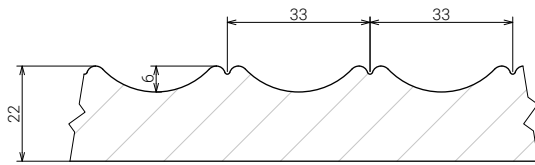

## SUNSET 64 MILLING

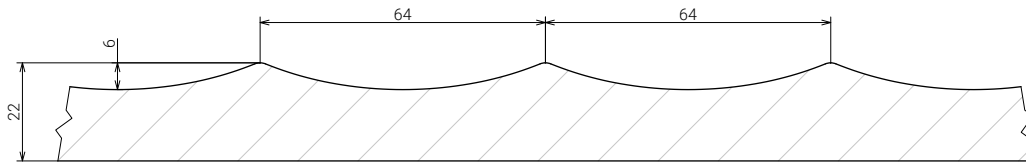

## FANCY 69 MILLING

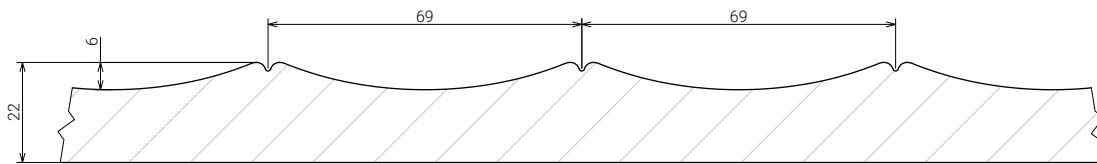

## AIRY 74 MILLING

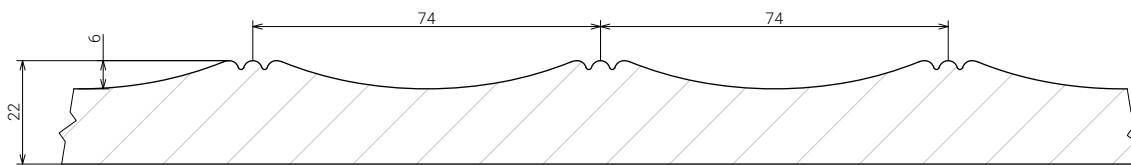





# FRONTS PAINTED

## Variety of lines collection

### MATERIALS FROM VISUALIZATION:

- Color: NCS 1005-Y50R
- Milling: Flores 45
- Countertop Acrylic Grandex Adventure A-418 Oak Wood 12 mm
- Backsplash: Sintered Stone NEOLITH ClasStone Calacatta 01R silk 6 mm

*Bel Viso*<sup>®</sup>

## FLORES 55 MILLING

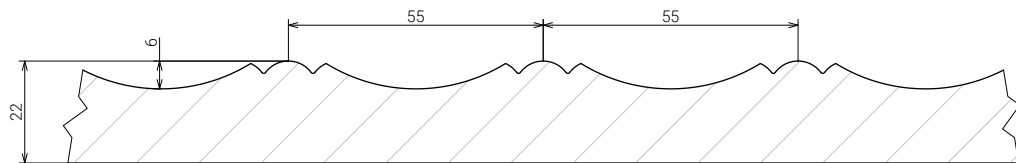

## FLORES 45 MILLING

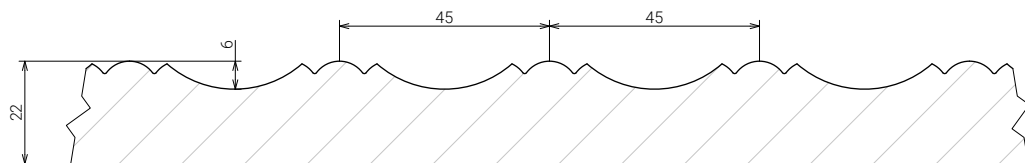

## NERO 100 MILLING

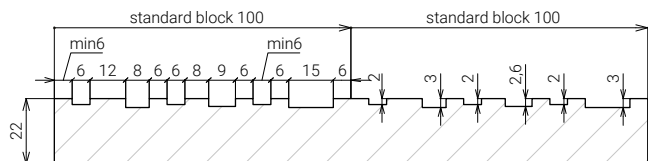

## BRIGHT 12 MILLING

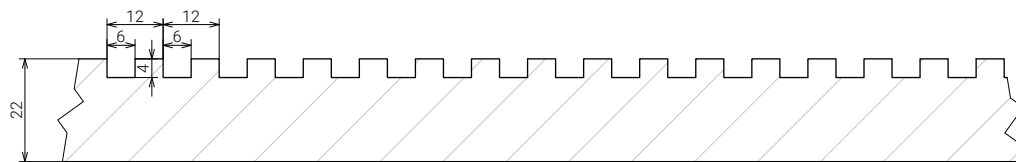

## LIBERTY 114 MILLING

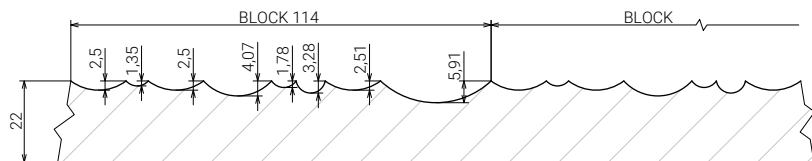

# FRONTS PAINTED

## Variety of lines collection

### MATERIALS FROM VISUALIZATION:

- Color: NCS 1010-Y60R
- Milling: Liberty
- Handle Cosma M 12951.192 steel /art. 21819
- Countertop Acrylic Getacore GC 2388 Miracle Beach 10 mm
- Backsplash: Sintered Stone Inalco Petra Crema abujardado 4 mm



*Bel Viso*<sup>®</sup>

## CAVE 12 MILLING

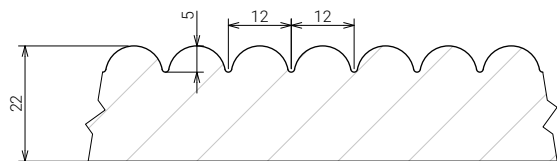

## CAVE 14 MILLING

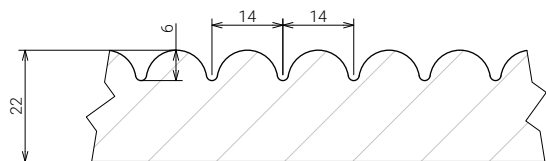

## CAVE 17 MILLING

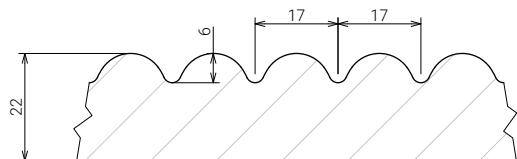

## CAVE 20 MILLING

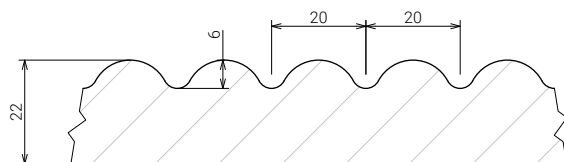

## CAVE 28,5 MILLING

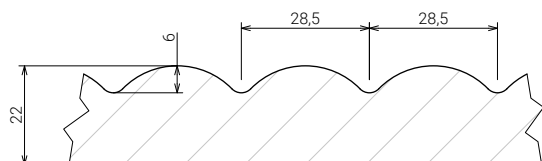



# FRONTS PAINTED

---

## MATERIALS FROM VISUALIZATION:

- Color: NCS S 4005Y20R
- Milling: Alba
- Handle Marella M 15194.160 graphite /art. 69687
- Handle Marella M 15194.320 graphite /art. 69690
- Countertop Kronospan K211 PE Porfyr Black 38 mm /art. 43306
- Skinali (on the diamond glass 6 mm) /art. 49756

*Bel*  *Viso*<sup>®</sup>

# ALBA MILLING



RAL 9003



RAL 9001



RAL 9016



RAL 7036



RAL 9010



WCP 115

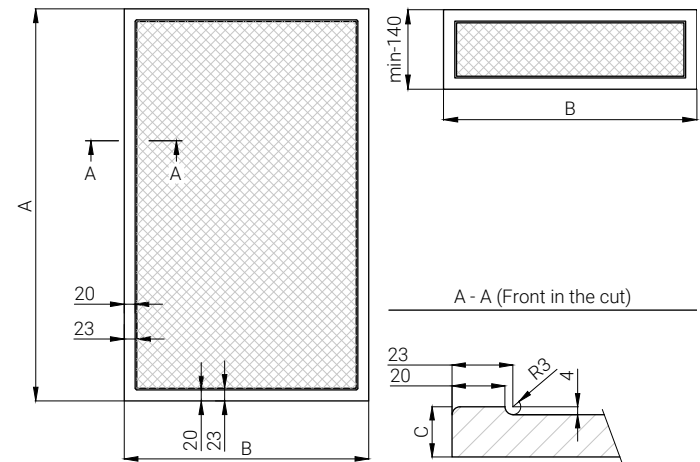



# FRONTS PAINTED

---

## MATERIALS FROM VISUALIZATION:

- Color: RAL 7043 Transport gray B
  - Milling: Geometry
- Handle 224-160 black /art. 91303
- Countertop Egger F117/ST76/R3-1U Stone Ventura black 38 mm /art. 69510
- Backsplash: MDF Fenix NTM 0751 Jaipur / Arpa 0759 10 mm /art. 62123

*Bel Viso*<sup>®</sup>

# GEOMETRY MILLING



RAL 9002



RAL 7045



RAL 1013



RAL 7024



RAL 1015



RAL 7004

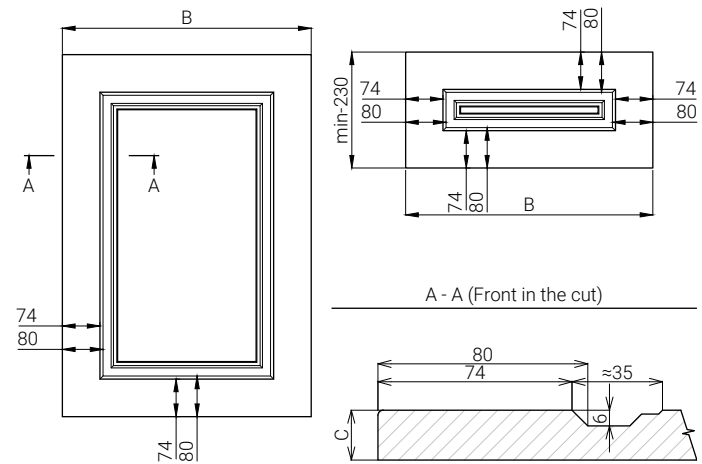



# FRONTS PAINTED

---

## MATERIALS FROM VISUALIZATION:

- Color: WCP 148
- Milling: Glory
- Handle Cosma M 12749.320 matte nickel /art. 21844
- Handle Cosma M 12748.160 matte nickel /art. 21842
- Countertop: Corian acrylic sheet (C)  
Warm Gray 12 mm /art. 43342
- Backsplash: MDF Fenix NTM Bloom 0771 /  
Fenix NTM Bloom 0771 19 mm /art. 115723

*Bel Visa*<sup>®</sup>



# GLORY MILLING



RAL 9005

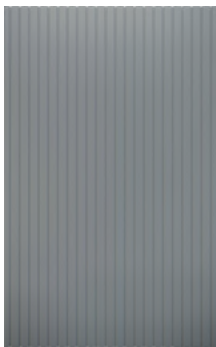

RAL 7037



RAL 7012

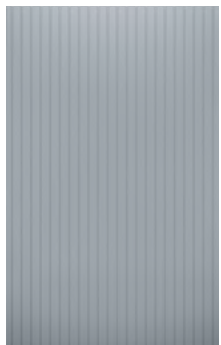

RAL 7040



RAL 1019

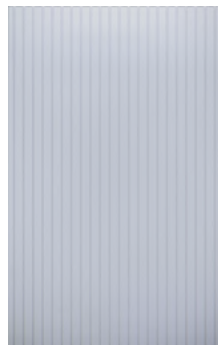

WCP 127

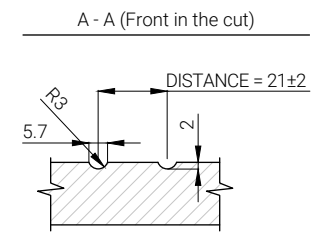
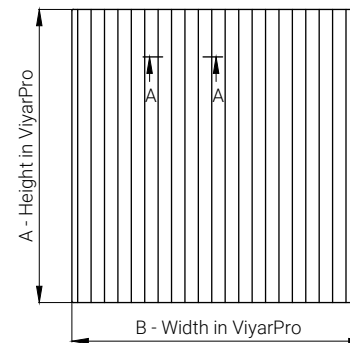

# FRONTS PAINTED

---

## MATERIALS FROM VISUALIZATION:

- Color: NCS S 0804Y30R
- Milling: Grace
- Profile GOLA horizontal Ferro Fiori, L=4100 mm, type L nickel brush /art. 72558
- Profile GOLA horizontal Ferro Fiori with groove for LED, L=4100 mm, type C, nickel brush /art. 117884
- Countertop: MDF Arpa 3447 Ker 19 mm /art. 111176
- Backsplash: MDF Arpa 3447 Ker 10 mm /art. 84210

*Bel Viso*<sup>®</sup>



# GRACE MILLING



WCP 176



WCP 83



NCS S 2005Y50R



RAL 7016



RAL 7044



NCS S 1000N

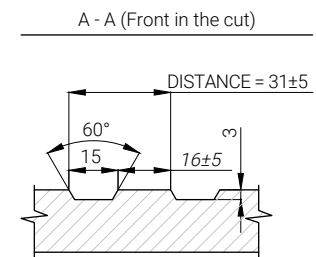
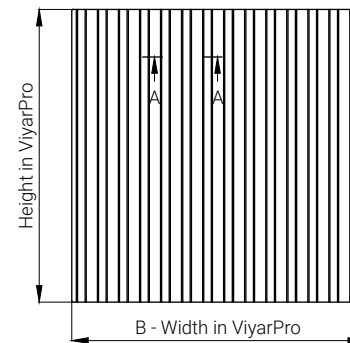



# FRONTS PAINTED

---

## MATERIALS FROM VISUALIZATION:

- Color: RAL 7031 Blue-gray
- Milling: Country
- Handle Marella M 15244.320 nickel /art. 34617
- Countertop Kronospan 4298 UE  
Atelier Light 38 mm /art. 21687
- Backsplash: Chipboard Kronospan 4298 SU  
Atelier Light 18 mm /art. 28717

*Bel Viso*<sup>®</sup>

# COUNTRY MILLING



NCS S 0300N



NCS S 0500N



RAL 1000



RAL 7046



RAL 7043



RAL 6005

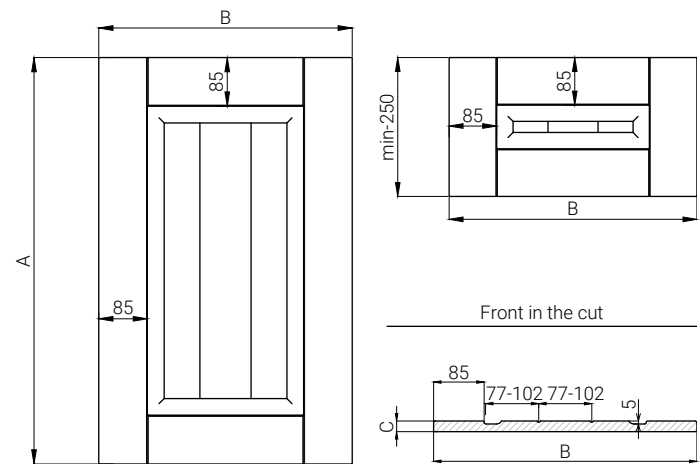

# FRONTS PAINTED

---

## MATERIALS FROM VISUALIZATION:

- Color: RAL 9003 Signal white
- Milling: Classic
- Handle Ferro Fiori D 4440.160 antique silver /art. 115334
- Handle Ferro Fiori D 4440.224 antique silver /art. 115337
- Countertop: Corian acrylic sheet (E) Everest 12 mm /art. 43255



*Bel Viso*<sup>®</sup>

# CLASSIC MILLING



RAL 7035



NCS S 2002Y50R



RAL 7042



RAL 7011



RAL 5014



RAL 7015

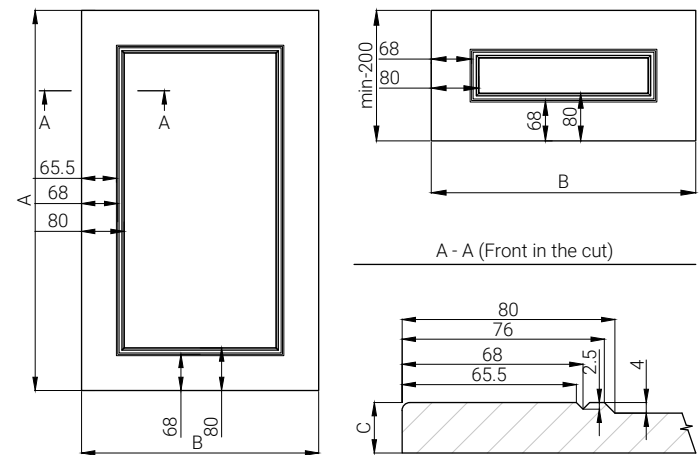



# FRONTS PAINTED

---

## MATERIALS FROM VISUALIZATION:

- Color: NCS S 7000N
- Milling: Costa
- Handle Marella CL 15231.160 antique silver /art. 46455
- Countertop: Corian acrylic sheet (C) Shale 12 mm /art. 43358

*Bel Viso*<sup>®</sup>



# COSTA MILLING



NCS S 1002Y50R



WCP 67



RAL 6034



RAL 5023



RAL 5024



RAL 7021

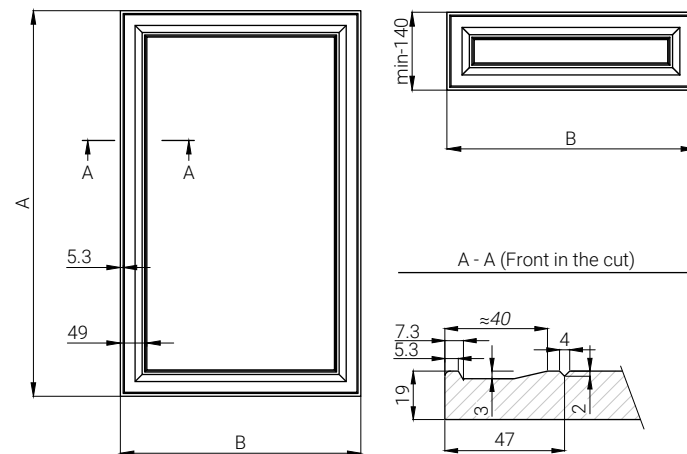

# FRONTS PAINTED

---

## MATERIALS FROM VISUALIZATION:

- Color: RAL 7024 Graphite gray
- Milling: Loft
- Handle Ferro Fiori M 0220.192 black brush /art. 11482
- Countertop Egger H3133 ST12 R3-1U  
Oak Davos truffle 38 mm /art. 35462
- Backsplash: 2-sided chipboard wall panel Ricci  
6019 AR/6133 AR 14 mm /art. 126888

*Bel Viso*<sup>®</sup>

# LOFT MILLING



NCS S 2500N



RAL 7032



NCS S 2005Y60R

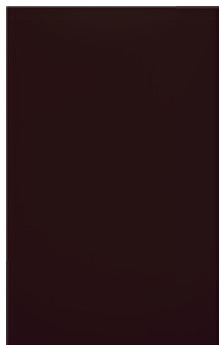

RAL 8017



RAL 6021



RAL 7030

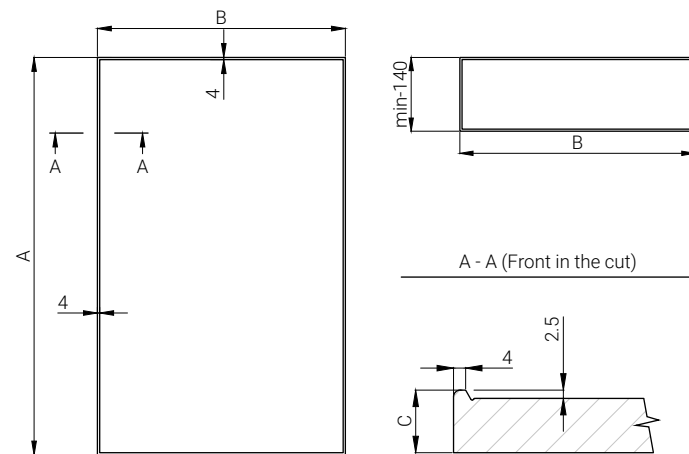

# FRONTS PAINTED

---

## MATERIALS FROM VISUALIZATION:

- Color: RAL 9023 Pearl dark grey
- Milling: Maura
- Compact laminate Fenix NTM 0720  
Ingo Black 12 mm /art. 94172



*Bel Viso*<sup>®</sup>

# MAURA MILLING



WCP 25



NCS S 1502Y50R



RAL 1012

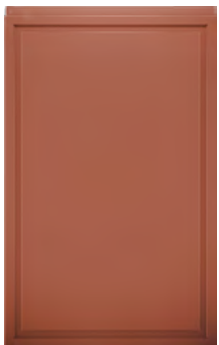

WCP 230

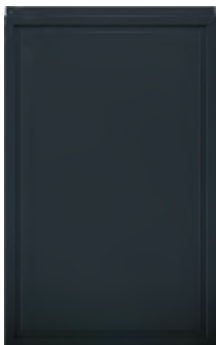

RAL 7031



RAL 6033

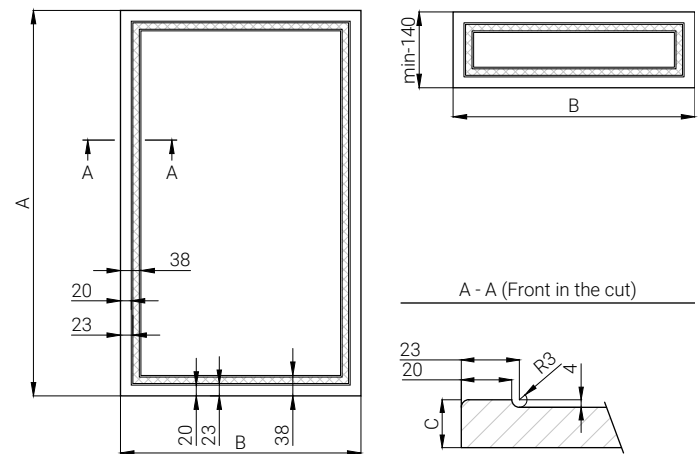

# FRONTS PAINTED

---

## MATERIALS FROM VISUALIZATION:

- Color: RAL 7044 Gray silk
- Milling: Nicole
- Handle Marella M 15205.160 polished nickel /art. 46467
- Countertop Kronospan K026 26 Petra Marble 38 mm /art. 26828



*Bel Viso*<sup>®</sup>

# NICOLE MILLING



WCP 133



WCP 148



RAL 6019



RAL 1035



NCS S 4005Y50R



RAL 1001

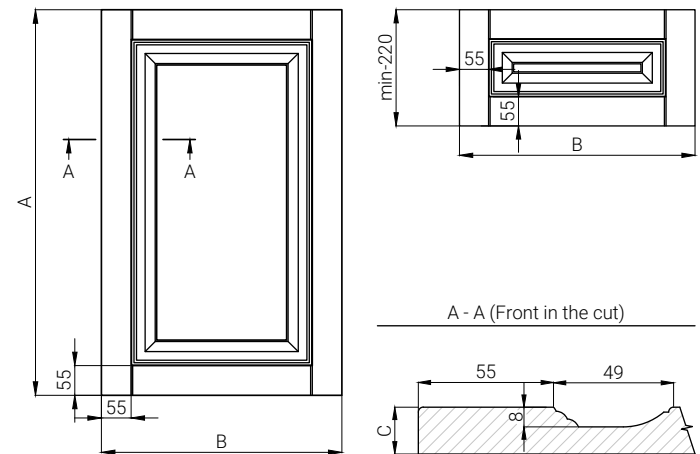



# FRONTS PAINTED

---

## MATERIALS FROM VISUALIZATION:

- Color: RAL 7030 Stone gray
- Milling: Paola
- Countertop Arpa 3381 LUNA moisture resistant 40 mm /art. 30169
- Backsplash: Arpa 3381 LUNA



*Bel Viso*<sup>®</sup>

# PAOLA MILLING



RAL 9018



RAL 5001



RAL 5009



NCS S 1505Y30R



NCS S 2005Y80R



NCS S 4005Y20R

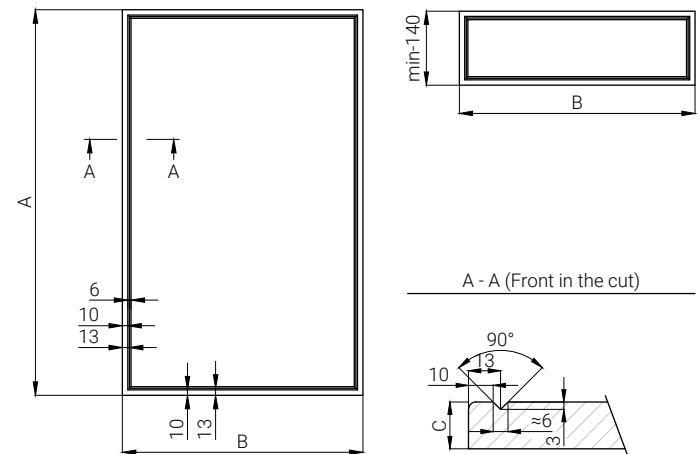

# FRONTS PAINTED

---

## MATERIALS FROM VISUALIZATION:

- Color: NCS S 7000N, NCS S 1000N
- Milling: Frame
- Handle Marella M 15192.160 titanium /art. 69679

*Bel Viso*<sup>®</sup>



# FRAME MILLING



WCP 294



NCS S 3010B30G



NCS S 0804Y30R



RAL 8025



RAL 9011



RAL 7005

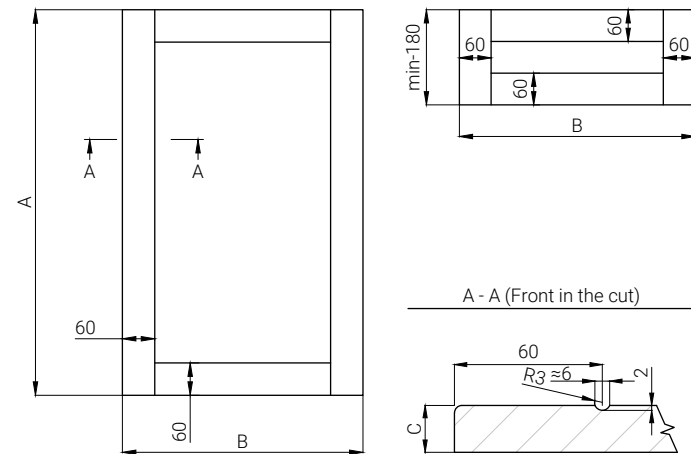

# FRONTS PAINTED

---

## MATERIALS FROM VISUALIZATION:

- Color: RAL 6021 Pale green
- Milling: Sigma
- Handle Marella CL 24228.01.032 black matte /art. 117515



*Bel Viso*<sup>®</sup>

# SIGMA MILLING



RAL 5020



RAL 5007



RAL 6027



NCS S 7000N



RAL 9023



NCS S 1500N

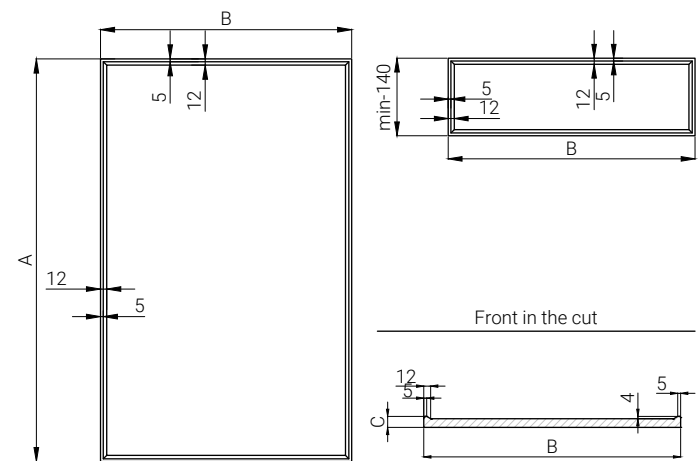

# FRONTS PAINTED

---

## MATERIALS FROM VISUALIZATION:

- Color: NCS S 1500N
- Milling: Simple
- Handle Marella M 15191.160 black matte /art. 69671
- Countertop Egger F117/ST76/R3-1U  
Stone Ventura black 38 mm /art. 69510
- Backsplash: 2-sided wall panel Egger F117 ST76 /  
F121 ST87 9.2 mm /art. 70258

*Bel Viso*<sup>®</sup>



# SIMPLE MILLING



RAL 9010



WCP115



NCS S 2005Y40R



RAL 6034



RAL 7004



RAL 1019

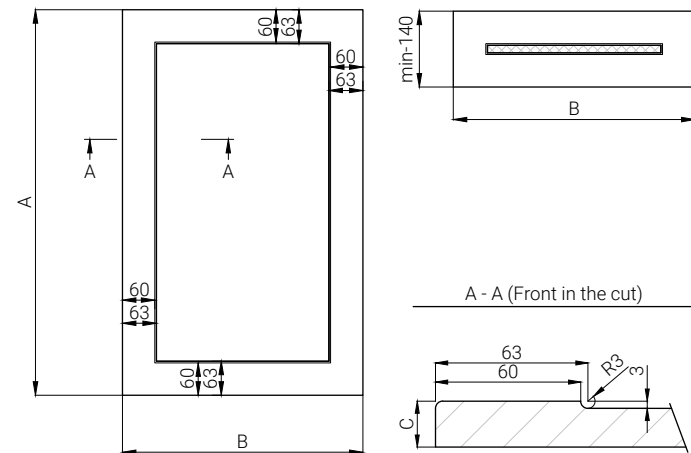





# FRONTS PAINTED

---

## MATERIALS FROM VISUALIZATION:

- Color: RAL 7042
- Milling: without milling
- Handle Marella M 15244.320 dark nickel /art. 34619
- Countertop Kronospan K095 SU Marmut terrazzo light 38 mm /art. 44632
- Skinali (on the diamond glass 6 mm) /art. 49756

*Bel Viso*<sup>®</sup>

## WITHOUT MILLING

---

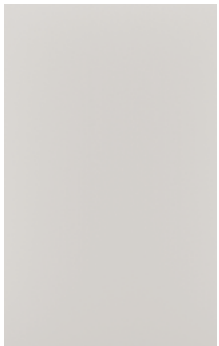

NCS S 1500N

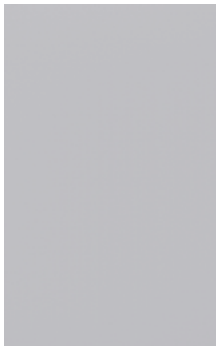

WCP 133



RAL 7042



RAL 7046

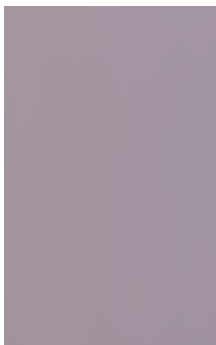

RAL 7036



RAL 7043



# FILM FRONTS

---

## LEADERS OF UNIVERSALITY

Film fronts are a universal and affordable solution for any of your projects. More than 150 trendy decors of films – monochrome, glossy, matte, imitation wood and metal and other materials, with and without milling.

At the heart of film fronts is the MDF of high density. For coating, we use PVC film from German and Italian manufacturers, in particular

the exclusive collections of Serica and Continental films with improved resistance to damage. Before pressing the film, the glue is applied to the entire surface and ends of the front to achieve the highest quality.

Film fronts are easy to care for, have optimal resistance to scratches, temperature changes and dyes.

*Bel Visa*<sup>®</sup>

---







## ADDITIONAL SERVICES

---

Milled handle 

Window case 

Double-sided coating 

Patina 

Cut-in handle 

Express production 

Individual milling 

# FRONTS FILM

---

## MATERIALS FROM VISUALIZATION:

- Front: PVC film Cashmere NL 7393 (SERICA) /art. 49139
  - Milling: Bruno
- Handle Marella M 15187.192 graphite /art. 37297
  - Countertop: Ceramogranite Neolith Pietra Gray matte 12 mm /art. 120692
  - Backsplash: Ceramogranite Neolith Pietra Gray matte 12 mm /art. 120692



*Bel Viso*<sup>®</sup>

# BRUNO MILLING



NL 7473 (SERICA)  
Light gray



NL 7393 (SERICA)  
Cashmere



NL 7455 (SERICA)  
Rain clouds

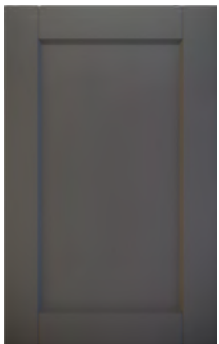

NL 7522 (SERICA)  
Ice



VL 4258 (SERICA)  
Kombu green



RL 5989 (SERICA)  
Marsala

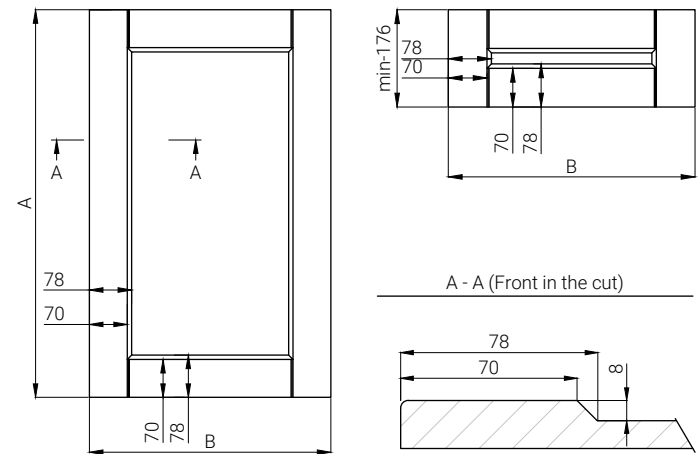

# FRONTS FILM

---

## MATERIALS FROM VISUALIZATION:

- Front: PVC film Lead NL 7522 (SERICA) /art. 49140
  - Milling: Inel
- Handle Marella M 15205.160 polished nickel /art. 46467
- Countertop: Compact laminate Fenix NTA 5000  
Steel Hamilton black core 10 mm /art. 121680



*Bel Visa*<sup>®</sup>

# INEL MILLING



YEM16-B9  
Mussel structure



VL 4246 (SERICA)  
Fjord



NL 7361 (SERICA)  
Gray stone



BL 6221 (SERICA)  
Indigo

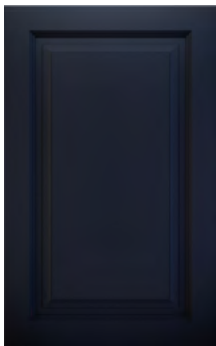

BL 6230 (SERICA)  
Marine blue



RL 5983 (SERICA)  
Terracotta

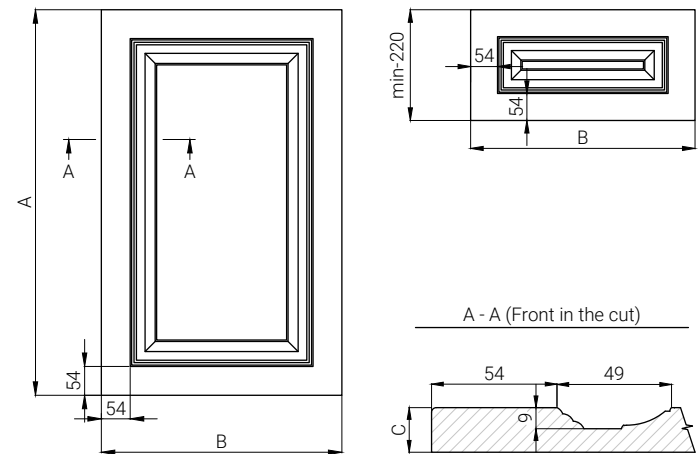



# FRONTS FILM

---

## MATERIALS FROM VISUALIZATION:

- Front: PVC film Rain clouds NL 7455 (SERICA) /art. 49131
  - Milling: Crost
- Profile Gola horizontal, L = 4000 mm, type C, black brush, Scilm /art. 58411
- Profile Gola horizontal, L = 4000 mm, type L, black brush, Scilm /art. 58410
- Countertop: Compact laminate Fenix NTM 0720 Ingo Black 12 mm /art. 94172
- Backsplash: Compact laminate Fenix NTM 0720 Ingo Black 12 mm /art. 94172

*Bel Visa*<sup>®</sup>

# CROST MILLING



NL 7522 (SERICA)  
Ice



RL 5983 (SERICA)  
Terracotta



HRB3211UD-B10-0,35  
Green ice



BL 6230 (SERICA)  
Marine blue

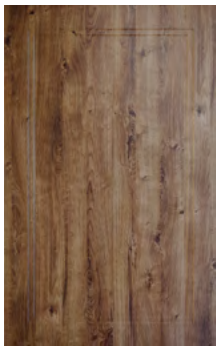

F4242526  
Oak Ribbeck



NCAB4-B9  
Cashmere structure

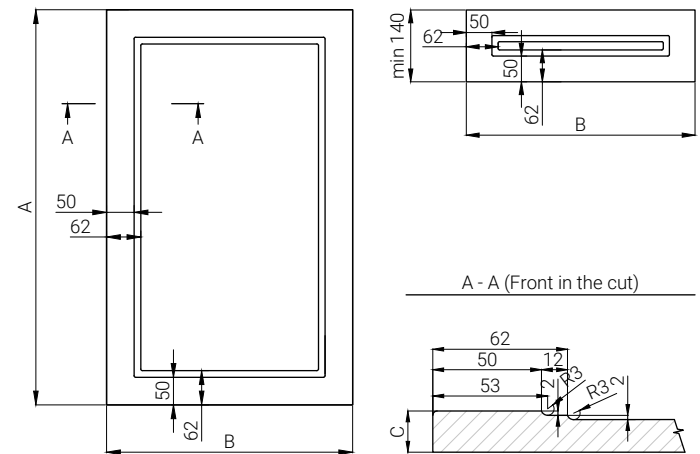

# FRONTS FILM

---

## MATERIALS FROM VISUALIZATION:

- Front: PVC film Marine blue BL 6230 (SERICA) /art. 49134
  - Milling: Modern
- Handle Marella M 15191.160 titanium /art. 69675
  - Countertop Egger F095/ST87/R3-1U Marble  
Sienna gray 38 mm /art. 69508
- Backsplash: 2-sided wall panel Egger F095 ST87 /  
F041 ST15 9.2 mm /art. 70256

*Bel Viso*<sup>®</sup>

# MODERN MILLING



KADR4-B9  
Light gray structure



NCAB5-B9  
Gray stone structure



F4242301  
Sanremo sand



F4242489  
Oak Riviera

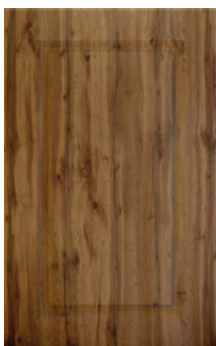

F4242499  
Oak One



F4242526  
Oak Ribbeck

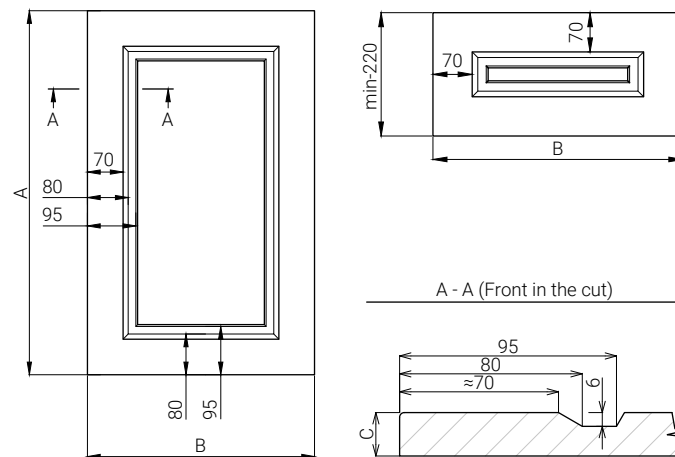

# FRONTS FILM

---

## MATERIALS FROM VISUALIZATION:

- Front: PVC film Terracotta RL 5983 (SERICA) /art. 68450
  - Milling: Frame with sample
- Handle VV 323/160, black, Turkey /art. 115583
- Countertop: Compact laminate Arpa 0509  
black core 12 mm /art. 94166



*Bel Viso*<sup>®</sup>

# FRAME WITH SAMPLE MILLING

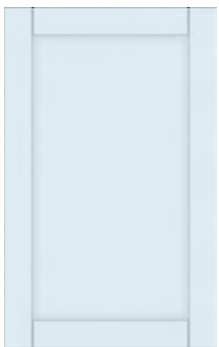

F4275001  
Cold white



F4292031  
Painted tree



D4151-001-M-0,45  
Galaxy white



NL 7455 (SERICA)  
Rain clouds



D6326-804-P5  
Geraldine

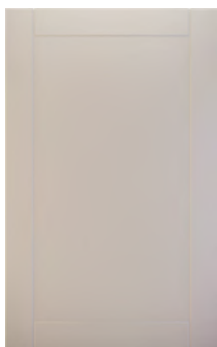

AL 2156 (SERICA)  
Foam

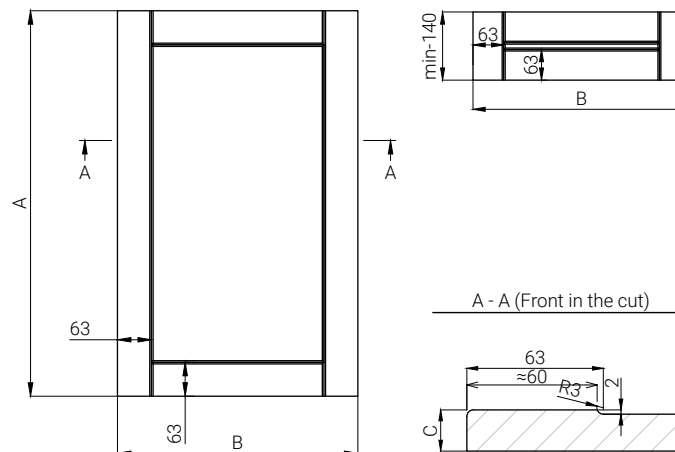

# FRONTS FILM

---

## MATERIALS FROM VISUALIZATION:

- Front: PVC film Fjord VL 4246 (SERICA) /art. 49127
  - Milling: Fresco
- Handle Marella M 15244.320 nickel /art. 34617
  - Countertop: Arpa 3447 Ker 38 mm
  - Backsplash: Arpa 3447 Ker



*Bel Visa*<sup>®</sup>

# FRESCO MILLING



NL 7473 (SERICA)  
Light gray



NL 7522 (SERICA)  
Ice



NL 7455 (SERICA)  
Rain clouds



NCAB5-B9  
Gray stone structure



VL 4246 (SERICA)  
Fjord



VL 4258 (SERICA)  
Kombu green

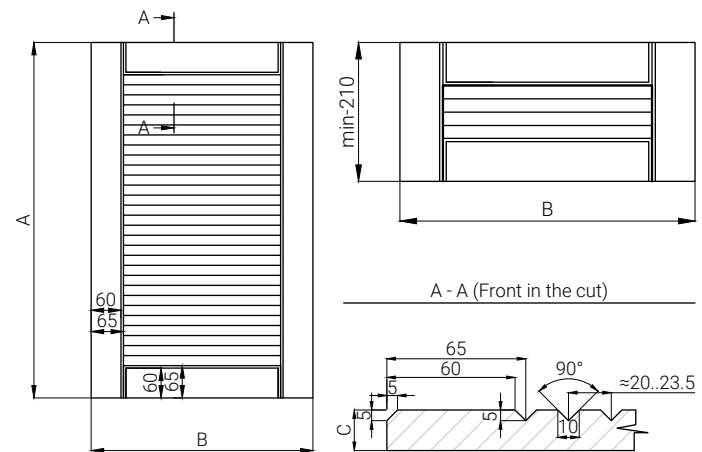



# FRONTS FILM

---

## MATERIALS FROM VISUALIZATION:

- Front: PVC film Kombu green VL 4258 (SERICA) /art. 68448
  - Milling: Adele
- Handle Marella M 15191.160 black matte /art. 69671
  - Countertop Egger F117/ST76/R3-1U Stone Ventura black 38 mm /art. 69510
- Backsplash: 2-sided wall panel Egger F117 ST76 / F121 ST87 9.2 mm /art. 70258

*Bel Viso*<sup>®</sup>

# ADELE MILLING



NL 7522 (SERICA)  
Ice



BL 6230 (SERICA)  
Marine blue



VL 4258 (SERICA)  
Kombu green



RL 5983 (SERICA)  
Terracotta



RL 5989 (SERICA)  
Marsala



F4242526  
Oak Ribbeck

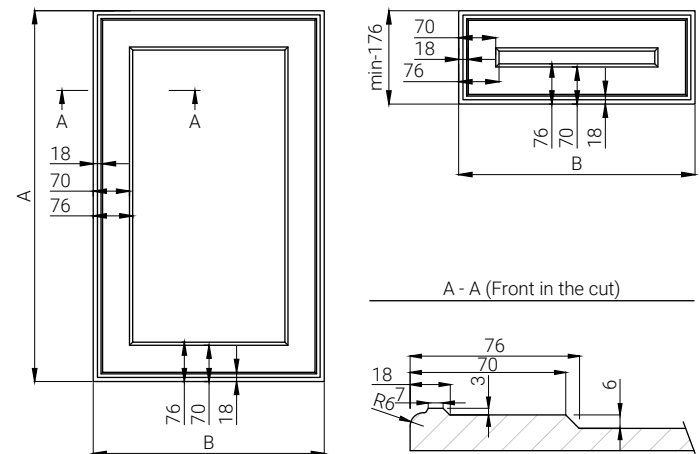

# FRONTS FILM

---

## MATERIALS FROM VISUALIZATION:

- Front: PVC film Marine blue BL 6230 (SERICA) /art. 49134
  - Milling: Louis
- Handle Marella CL 24228.01.032 black matte /art. 117515



*Bel Viso*<sup>®</sup>

# LOUIS MILLING



NL 7393 (SERICA)  
Cashmere



D6326-804-P5  
Geraldine



NL 7522 (SERICA)  
Ice

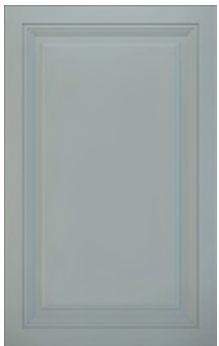

VL 4246 (SERICA)  
Fjord



NL 7455 (SERICA)  
Rain clouds



BL 6221 (SERICA)  
Indigo

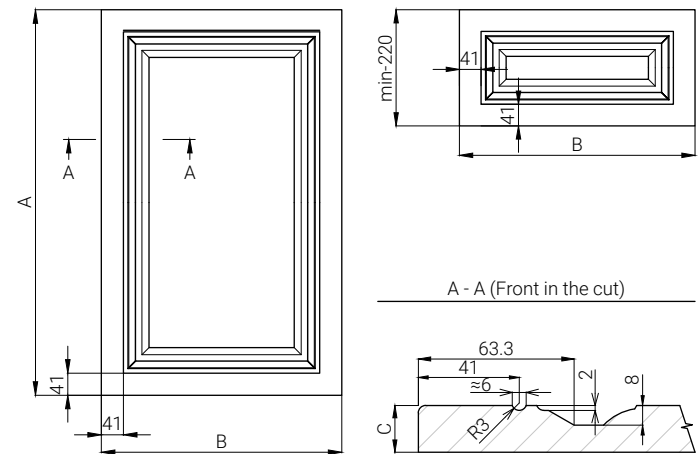

# FRONTS FILM

---

## MATERIALS FROM VISUALIZATION:

- Front: PVC film Geraldine D6326-804-P5 /art. 67878  
PVC film Mussel structure YEM16-B9 /art. 28382
  - Milling: Soul
- Handle Marella M 15194.160 graphite /art. 69687
- Handle Marella M 15194.320 graphite /art. 69690

*Bel Viso*<sup>®</sup>

# SOUL MILLING



D4151-001-M-0,45  
Galaxy white



VL 4246 (SERICA)  
Fjord



D6326-804-P5  
Geraldine



KADR4-B9  
Light gray structure



YEM16-B9  
Mussel structure



VL 4258 (SERICA)  
Kombu green

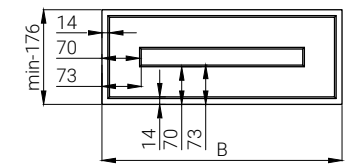
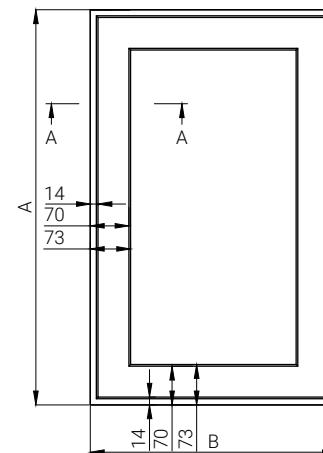

A - A (Front in the cut)

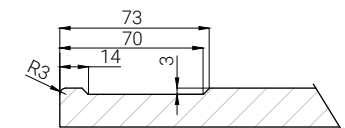

# FRONTS FILM

---

## MATERIALS FROM VISUALIZATION:

- Front: PVC film Geraldine D6326-804-P5 /art. 67878
  - Milling: Destiny
- Handle Cosma M 12749.320 matte nickel /art. 21844
- Countertop Kronospan K025 SQ Petra  
Marble Brown 38 mm /art. 44997

*Bel Viso*<sup>®</sup>

# DESTINY MILLING

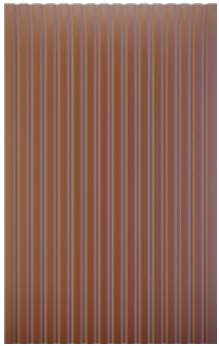

RL 5983 (SERICA)  
Terracotta

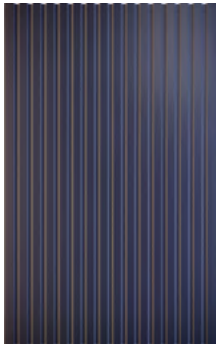

BL 6230 (SERICA)  
Marine blue



F4242499  
Oak One



F4242489  
Oak Riviera



NCAB5-B9  
Gray stone structure



D6326-804-P5  
Geraldine

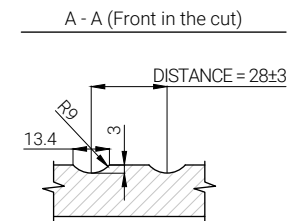
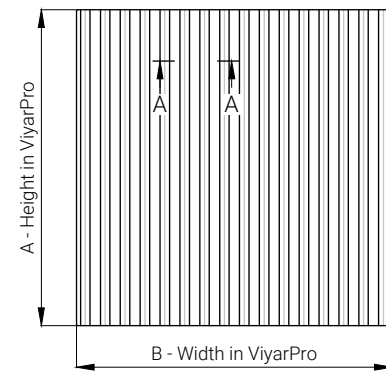



# FRONTS FILM

---

## MATERIALS FROM VISUALIZATION:

- Front: PVC film Gray stone structure NCA B5-B9 /art. 28385
  - Milling: Corrado
  - Handle Marella M 15244.320 nickel /art. 34617
- Countertop Luxeform W015-1 U Black 38 mm /art. 65303

*Bel Viso*<sup>®</sup>

# CORRADO MILLING

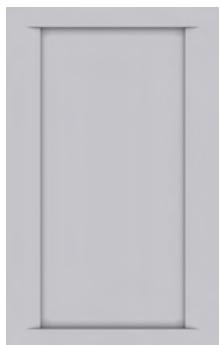

NL 7455 (SERICA)  
Rain clouds



VL 4246 (SERICA)  
Fjord

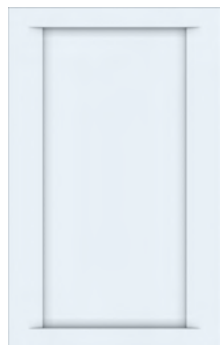

F4275001  
Cold white



VL 4258 (SERICA)  
Kombu green



F4242526  
Oak Ribbeck



NL 7522 (SERICA)  
Ice

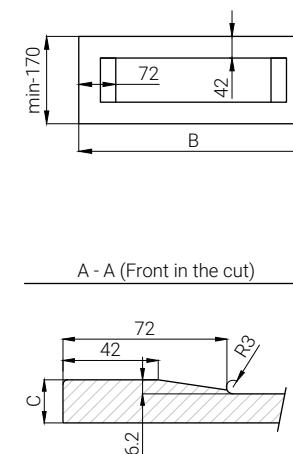
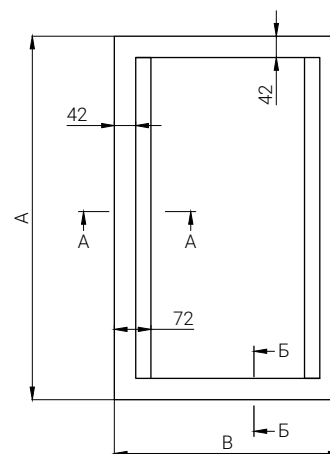

A - A (Front in the cut)

# FRONTS FILM

---

## MATERIALS FROM VISUALIZATION:

- Front: Magnolia gloss YEM-61PG
- Milling: X-Mystic
- Handle Marella M 24232.30 nickel /art. 69713



*Bel Viso*<sup>®</sup>

# X-MYSTIC MILLING

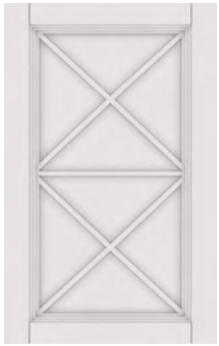

NL 7473 (SERICA)  
Light gray



VL 4246 (SERICA)  
Fjord



BL 6230 (SERICA)  
Marine blue



YEM16-B9  
Mussel structure



D6326-804-P5  
Geraldine



F4242489  
Oak Riviera

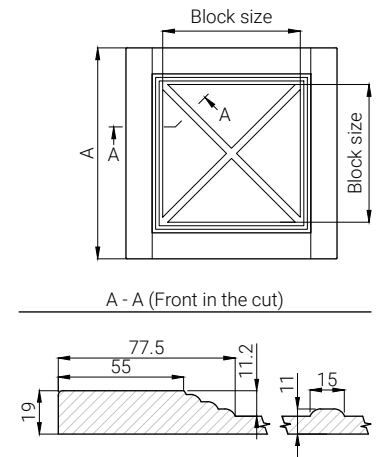
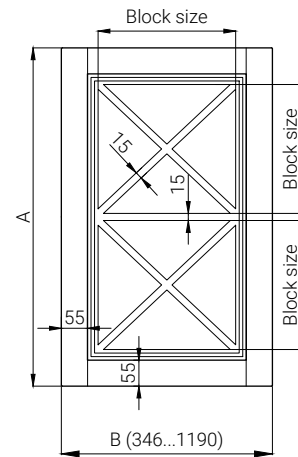

# FRONTS FILM

---

## MATERIALS FROM VISUALIZATION:

- Front: PVC film Kombu green VL 4258 (SERICA) /art. 68448
  - Milling: X-Rosso
- Handle Marella M 24232.30 nickel /art. 69713

*Bel Viso*<sup>®</sup>



# FRONTS FILM

---

## MATERIALS FROM VISUALIZATION:

- Front: PVC film Kombu green VL 4258 (SERICA) /art. 68448
  - Milling: Individual
- Handle VV 808/224, black, Turkey /art. 125791
- Countertop Kronospan K025 SQ Petra  
Marble Brown 38 mm /art. 44997



*Bel Visa*<sup>®</sup>

# INDIVIDUAL MILLING

---



RL 5983 (SERICA)  
Terracotta



BL 6221 (SERICA)  
Indigo

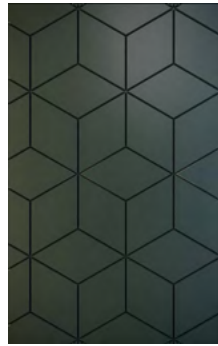

VL 4258 (SERICA)  
Kombu green



NL 7361 (SERICA)  
Gray stone

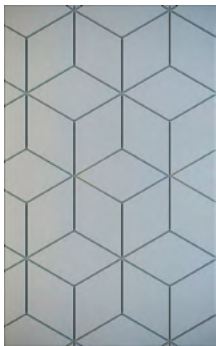

VL 4246 (SERICA)  
Fjord

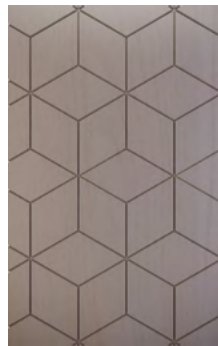

NCAB5-B9  
Gray stone structure





# HPL-FRONTS & FUSION COMBINED FRONTS

---

## INCREASED DAMAGE RESISTANCE

In search of something special, the Bel Viso team created HPL-fronts. These are fronts based on MDF-boards covered with a high-pressure laminate (HPL). In production, we use:

- **Fenix** – nanotechnological anti-fingerprint material with a deep matte surface and the ability to recover.

- **Arpa** – decorative multilayer HPL-laminate with exceptional strength.

HPL-fronts are practical in operation, have high resistance to UV radiation, various mechanical damage, moisture and dyes. Now the company's range has more than 80 decors.



**Also, available to order is our innovative development – Fusion combined fronts with an oak handle.**

The basis of the front is MDF with wooden beams around the perimeter. Both sides of the front are covered with nanomaterial Fenix and HPL ARPA. The visible carpentry joint in the upper beam emphasizes the naturalness of the material.

Arpa 

FENIX  NTM<sup>®</sup>

---







## ADDITIONAL SERVICES

---

Laser edging 

Double-sided coating 

Cut-in handle 



FRONTS

# HPL & FUSION

---

**MATERIALS FROM VISUALIZATION:**

- Front: Fenix NTM 0718 London Grey
- Countertop Kronospan K211 PE Porfyr Black 38 mm /art. 43306
- Backsplash: 2-sided chipboard wall panel Ricci 6019 AR / 6133 AR 14 mm /art. 126888

**FENIX** **NTM**<sup>®</sup>

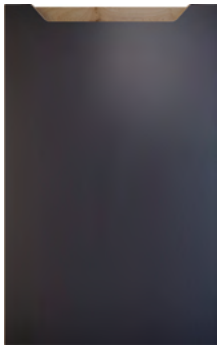

FUSION FENIX  
NTM 0724  
Bromine Gray



FUSION FENIX  
NTM 0750  
Commodore Green



FUSION FENIX  
NTM 0720  
Ingram Black



MDF FENIX  
NTM 0718  
London Grey

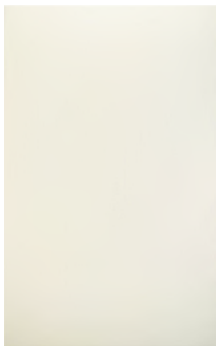

MDF FENIX  
NTM 0032  
Kos White



MDF FENIX  
NTM 0748  
Arizona Beige





FRONTS

# HPL & FUSION



MDF FENIX  
NTM 0751  
Jaipur



MDF FENIX  
NTM 0766  
Zante Gray



MDF FENIX  
BLOOM NTM 0773  
Green Brak



MDF FENIX  
BLOOM NTM 0771  
Light Blue Naxos



MDF FENIX  
BLOOM NTM 0772  
Yellow Kashmir



MDF FENIX  
BLOOM NTM 0770  
Red Askya

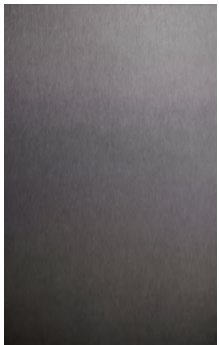

MDF FENIX  
NTA 5000  
Steel Hamilton

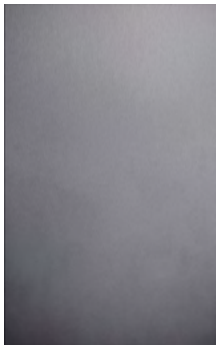

MDF FENIX  
NTA 5001  
Silver Ducat

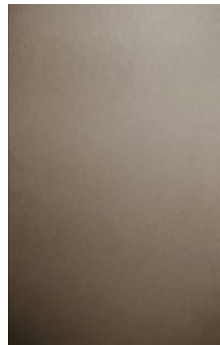

MDF FENIX  
NTA 5003  
Gold Cortez

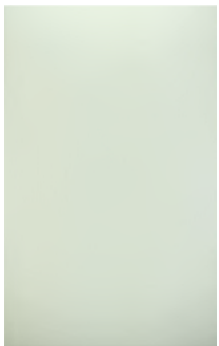

MDF FENIX  
NTM 0725  
Efes Gray



MDF FENIX  
NTM 0029  
Male White

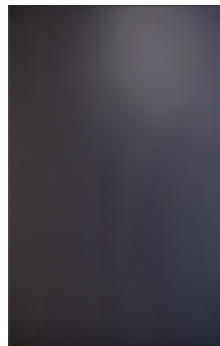

MDF FENIX  
NTM 0768  
Stromboli Gray





FRONTS

# HPL & FUSION

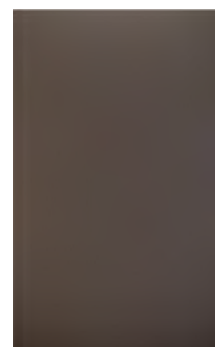

MDF FENIX  
NTM 0749  
Orinoco Chocolate



MDF FENIX  
NTM 0752  
Antrim Gray



MDF FENIX  
NTM 0719  
Luxor Beige



MDF FENIX  
NTM 0754  
Fes Blue



MDF FENIX  
NTM 0030  
Alaska White



MDF FENIX  
NTM 0717  
Castoro Ottawa



MDF FENIX  
NTM 0767  
Kolostai Beige



MDF FENIX  
NTM 0756  
Scary Gray

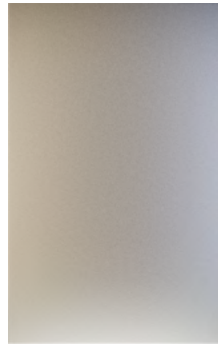

MDF FENIX  
NTM 2628  
Doha Zinc



MDF FENIX  
NTM 2629  
Doha Bronze

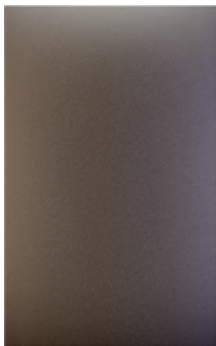

MDF FENIX  
NTM 2630  
Doha Anthracite



MDF FENIX  
NTM 2638  
Titanium







FRONTS

# HPL & FUSION

---

**MATERIALS FROM VISUALIZATION:**

- Front: Arpa 0001 Luna, 3276 Luna
- Countertop Arpa 0738 Erre 19 mm /art. 111207

Arpa 



FUSION ARPA  
0001  
Luna

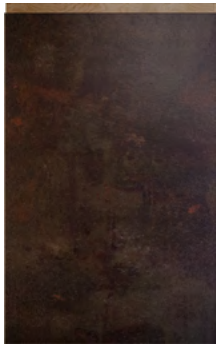

FUSION ARPA  
3276  
Luna

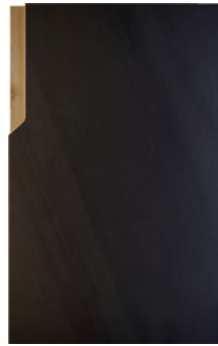

FUSION ARPA  
3408  
Losa



MDF ARPA  
4587  
Aleve



MDF ARPA  
3329  
Mika

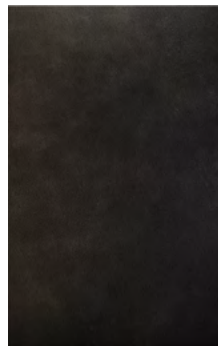

MDF ARPA  
3279  
Luna





FRONTS

# HPL & FUSION

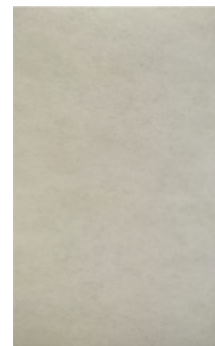

MDF ARPA  
3328  
Mika

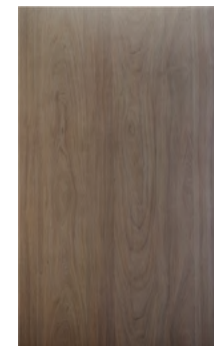

MDF ARPA  
4539  
Aleve

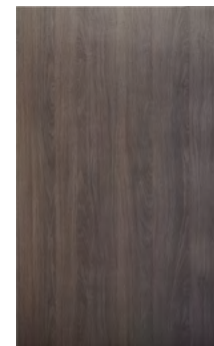

MDF ARPA  
4604  
Aleve

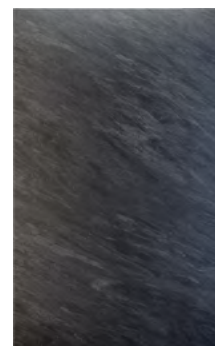

MDF ARPA  
3432  
Losa

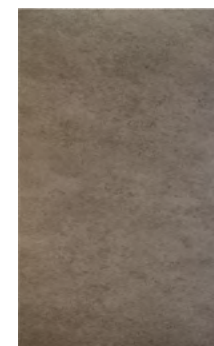

MDF ARPA  
3325  
Mika



MDF ARPA  
3447  
Ker

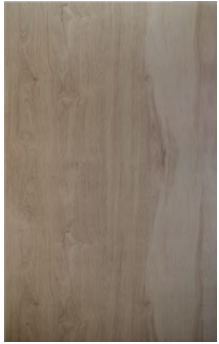

MDF ARPA  
4584  
Aleve

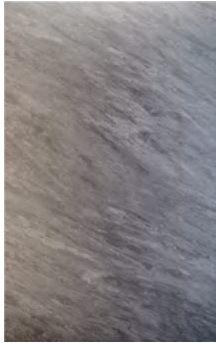

MDF ARPA  
3431  
Losa

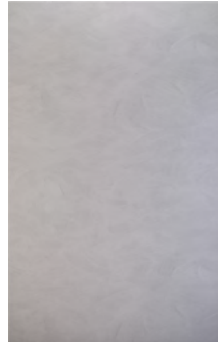

MDF ARPA  
3395  
Urban



MDF ARPA  
3331  
Luna



MDF ARPA  
3324  
Mika

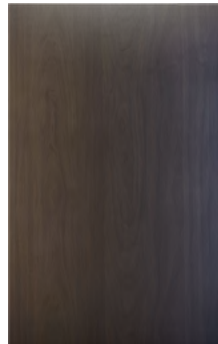

MDF ARPA  
4548  
Aleve





FRONTS

# HPL & FUSION



MDF ARPA  
4574  
Alev

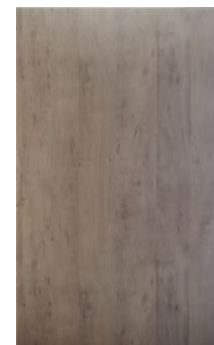

MDF ARPA  
4605  
Alev



MDF ARPA  
4585  
Alev



MDF ARPA  
0509  
Luna

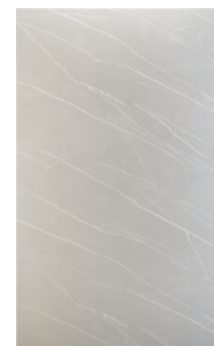

MDF ARPA  
3451  
Ker

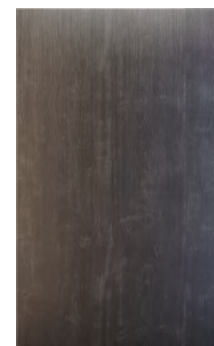

MDF ARPA  
4575  
Larix

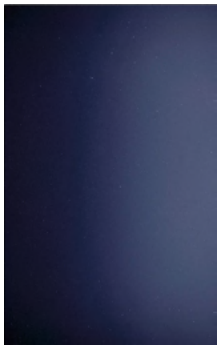

MDF ARPA  
BLOOM 0507  
Ker

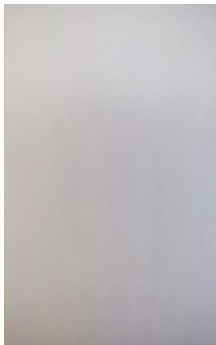

MDF ARPA  
BLOOM 0028  
Ker



MDF ARPA  
BLOOM 0700  
Ker



MDF ARPA  
BLOOM 0738  
Ker



MDF ARPA  
BLOOM 0776  
Ker



MDF ARPA  
BLOOM 0779  
Ker



# BEL VISO GLASS FRONTS

---

## METAL STRENGTH AND TRANSPARENT OPTIONS

Aluminum fronts Bel Viso Glass are a combination of a strong aluminum frame and glass or mirror filling. They are especially resistant to high temperatures and moisture, as well as unpretentious in care. That is why Bel Viso Glass is universal for any interior solution.

The fronts are based on more than 30 options of anodized aluminum profile with different types of coatings from the Spanish brand Cortizo, which protects the filling from mechanical damage.

The elements of the front are assembled at 45° and fixed together with metal corners.

The endless range of filling and services of UV printing, matting, color film application allows you to do something unique.

*Bel Viso*<sup>®</sup>

---

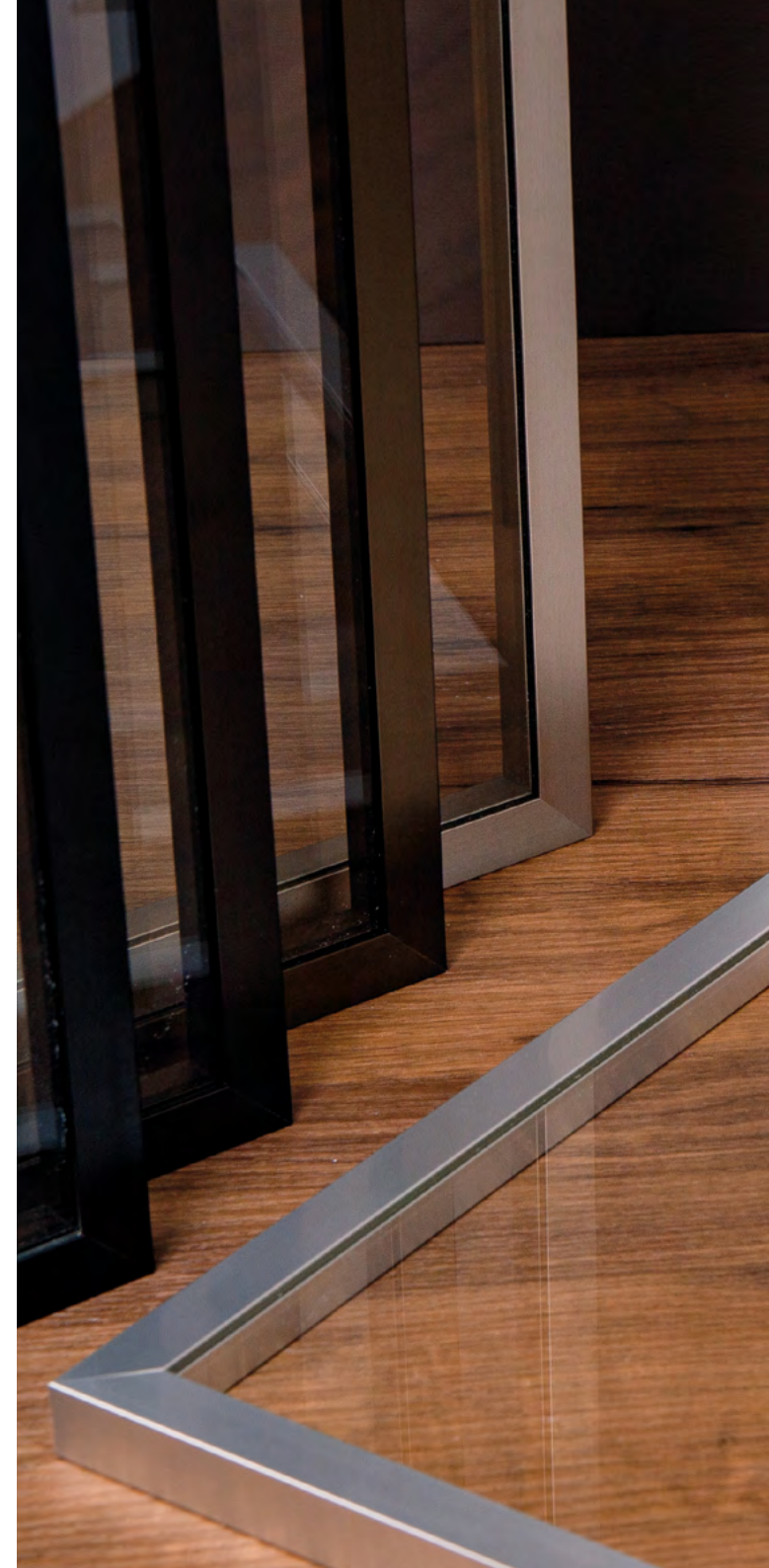





## ADDITIONAL SERVICES

---

Applying artistic finish 

RAL painting 

Cut-in handle 

Drilling hinge holes 





# FRONTS

# BEL VISO

# GLASS

---

#### MATERIALS FROM VISUALIZATION:

- Framed aluminum profile R-11 black /art. 52004
  - Tinted glass graphite 4 mm /art. 30049
- Handle Ferro Fiori M 0220.192 black brush /art. 11482
- Countertop Egger H3133 ST12 R3-1U Oak Davos truffle 38 mm /art. 35462
- Backsplash: 2-sided chipboard wall panel Ricci 6019 AR / 6133 AR 14 mm /art. 126888

*Bel Viso*<sup>®</sup>



R-1 Silver polished  
Window glass  
4 mm



R-1 Silver polished  
Mirror bronze  
4 mm



R-1 Silver brush polished  
Glass satin white  
4 mm

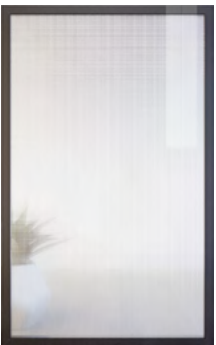

R-1 Black brush polished  
Window glass  
4 mm

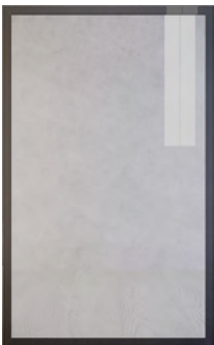

R-1 Black brush polished  
Mirror Spy  
4 mm



R-1 Black matte  
Glass Stopsol Classic  
graphite 4 mm

R-1

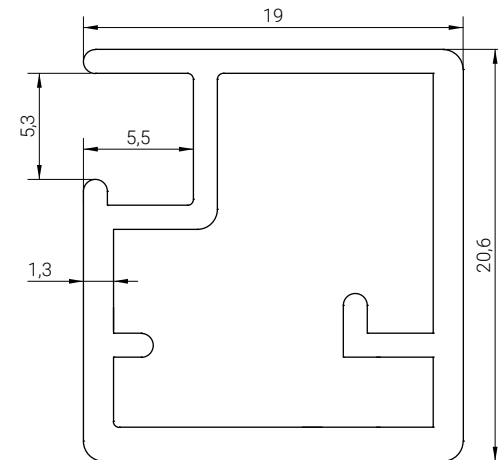



# FRONTS BEL VISO GLASS



R-1 Silver polished  
Glass Crystal colorless  
4 mm

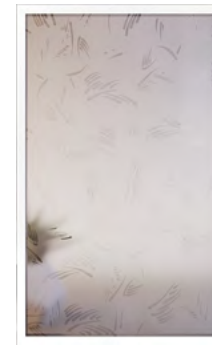

R-1 White matte  
Glass chale bronze  
4 mm



R-1 White matte  
Glass Lacobel Pearl  
White 1013 4 mm



R-1 Bronze matte  
Tinted glass bronze  
4 mm



R-1 Bronze matte  
Glass satin bronze  
4 mm



R-1 Graphite brush polished  
Glass Stopsol Classic  
Clear 4 mm

106 BEL VISO GLASS FRONTS

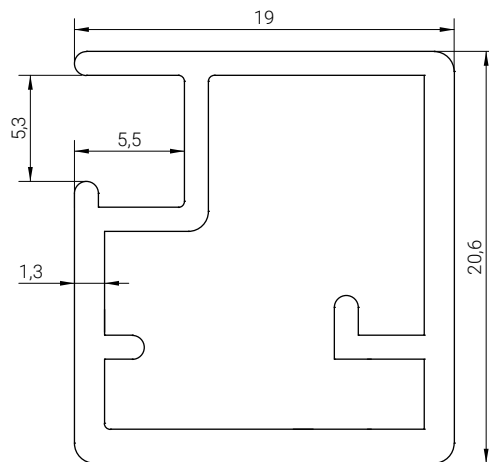

R-1



R-1 Gold polished  
Glass Planibel Dark Grey  
4 mm



R-1 Gold polished  
Glass Crystal Gold  
4 mm



R-4 Graphite brush polished  
Tinted glass graphite  
4 mm



R-1 Champagne brush  
Glass chale white  
4 mm

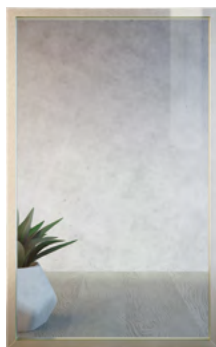

R-1 Nickel brush  
Window glass  
4 mm



R-4 Graphite brush polished  
Glass diamond  
4 mm

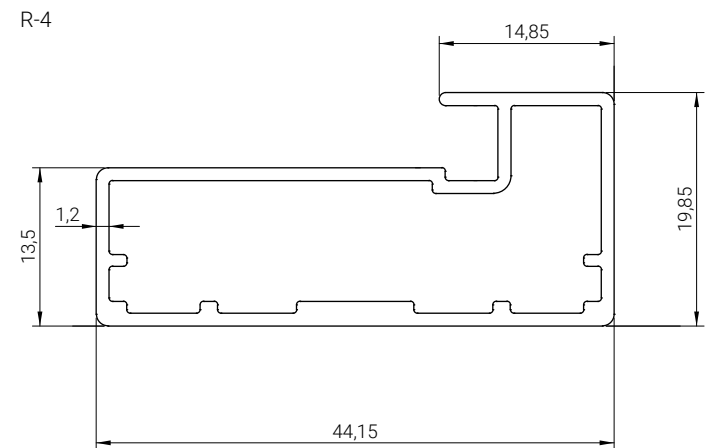



# FRONTS

## BEL VISO GLASS



R-4 Silver matte  
Glass Blackthorn white  
4 mm



R-4 Nickel brush  
Glass basak bronze  
4 mm



R-4 Bronze matte  
Glass Blackthorn bronze  
4 mm



R-4 Black matte  
Glass granite bronze  
4 mm



R-4 Black brush polished  
Glass Stopsol Classic  
bronze 4 mm



R-4 Black brush polished  
Glass diamond  
4 mm

108 BEL VISO GLASS FRONTS

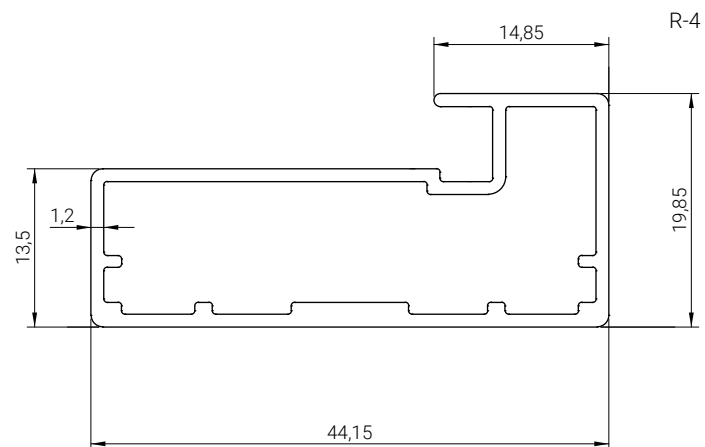



R-11 Silver  
Glass diamond  
4 mm, Oracal 076



R-11 Silver  
Mirror satin  
4 mm

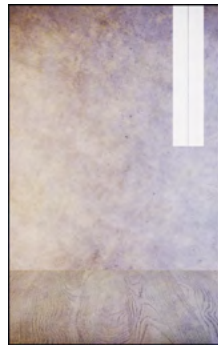

R-11 Black  
Mirror MORENA  
4 mm

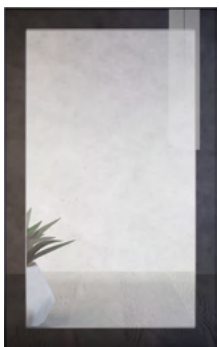

R-11 Black  
Tinted glass graphite  
4 mm, UV printing



R-11 Black  
Mirror satin graphite  
4 mm

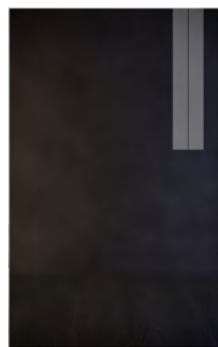

R-11 Silver  
Glass Lacobel Classic  
Black 9005 4 mm



R-11

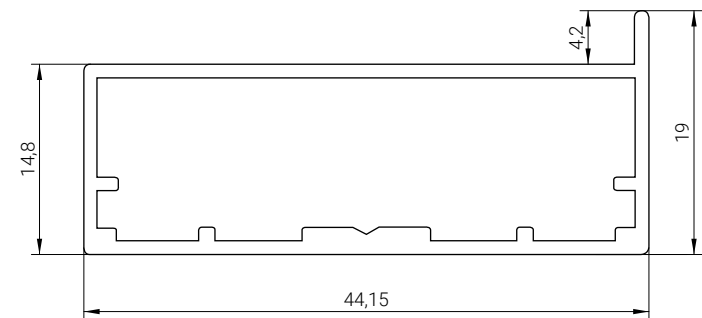



# FRONTS

## BEL VISO GLASS



Noventa Graphite brush  
Tinted glass graphite  
4 mm



Oculito Gold  
Double-sided golden  
mirror 4 mm



Suave White  
Window glass  
4 mm



Noventa Black matte  
Glass Planibel Dark Grey  
4 mm

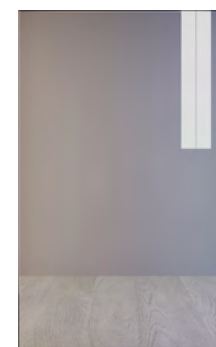

Oculito+ Entero Black brush  
Glass graphite  
4 mm

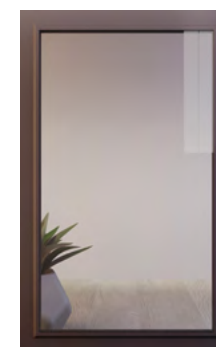

Suave bronze matte  
Tinted glass bronze  
4 mm

110 BEL VISO GLASS FRONTS

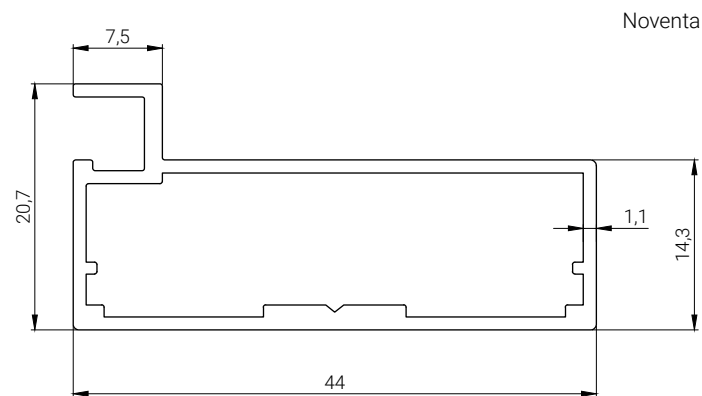

Suave

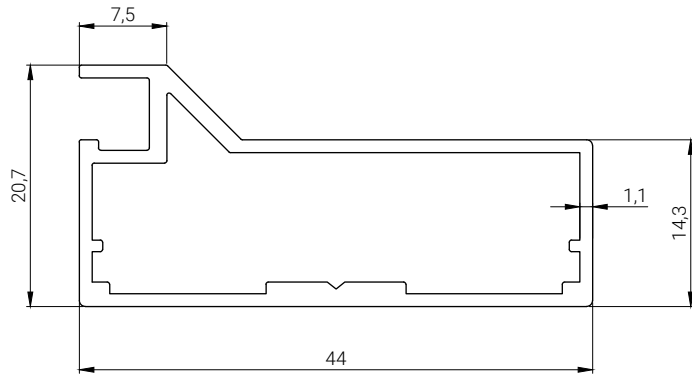

Entero

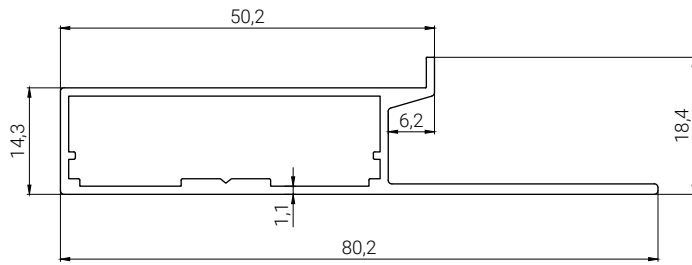

Oculto

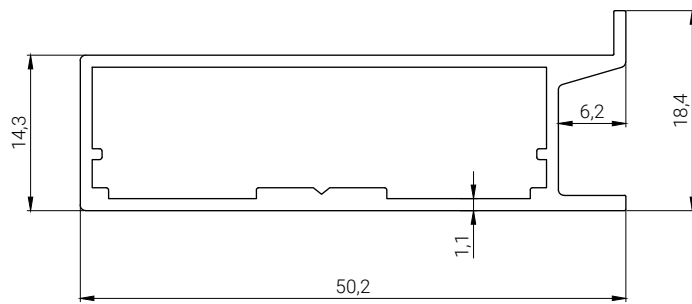

Espada

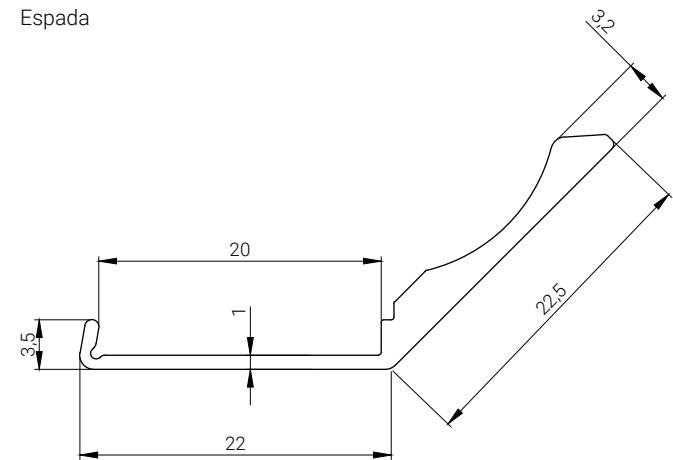



# ACRYLIC FRONTS

---

## SOPHISTICATION HAS A FORM

Acrylic fronts Bel Viso are created to embody the most sophisticated ideas in furniture design. In their manufacture, we take as basis panels with a glass laminate covering of Rauvisio Crystal from Rehau. This material doesn't differ visually from glass, but is more stable in operation.

Thanks to milling of a facet on the perimeter of a front, the 3D effect is reached. A total of 49 decors, including mirrored, monochrome and decorated plates with a matte or glossy surface.



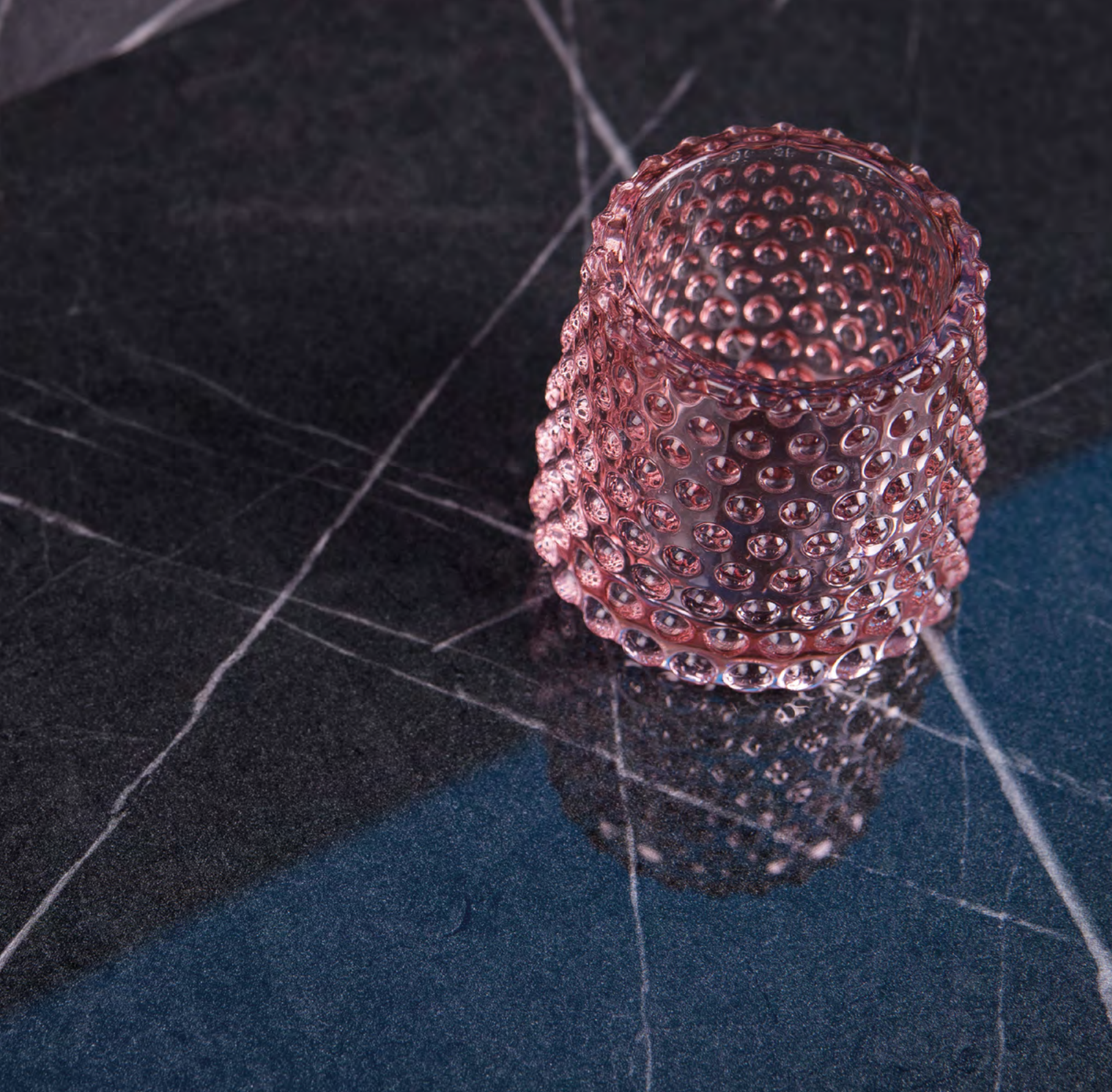

## ADDITIONAL SERVICES

---

Laser edging 

Cut-in handle 

# FRONTS ACRYLIC

---

## MATERIALS FROM VISUALIZATION:

- Front: Panel Rauvisio Crystal V2778 Bright white Gloss /art. 24036  
Panel Rauvisio Crystal 1969L Marble Romano /art. 51548
  - Handle Marella M 15194.160 graphite /art. 69687
  - Handle Marella M 15194.320 graphite /art. 69690



Rauvisio Crystal  
2409L  
Atlantico Gloss

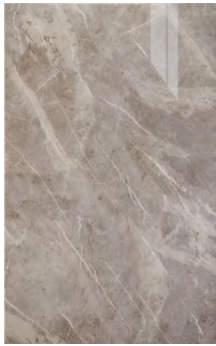

Rauvisio Crystal  
1969L  
Gloss Marble Romano



Rauvisio Crystal  
1721L  
Specular



Rauvisio Crystal  
V2778  
Gloss Bright white



Rauvisio Crystal  
73703  
Gloss Ivory

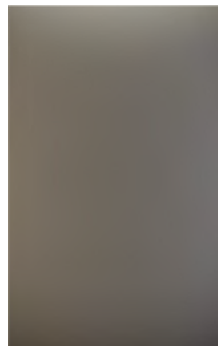

Rauvisio Crystal  
2109L  
Titanio Matte





# FRONTS ACRYLIC



Rauvisio Crystal  
1923L  
Gloss White-silver



Rauvisio Crystal  
1700L  
Matte Mint



Rauvisio Crystal  
1696L  
Matte Bright white



Rauvisio Crystal  
1687L  
Gloss Gray



Rauvisio Crystal  
1698L  
Matte Ivory



Rauvisio Crystal  
1702L  
Matte Smoky



Rauvisio Crystal  
1703L  
Matte Gray



Rauvisio Crystal  
1976L  
Gloss Bleached Wood



Rauvisio Crystal  
1697L  
Matte White



Rauvisio Crystal  
1911L  
Matte Light gray

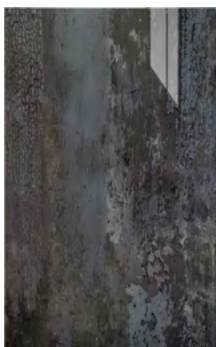

Rauvisio Crystal  
1975L  
Gloss Burnt Wood



Rauvisio Crystal  
1974L  
Gloss Antique Wood





# FRONTS ACRYLIC

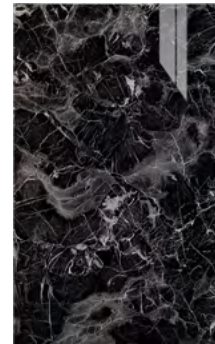

Rauvisio Crystal  
1971L  
Gloss Marble Black



Rauvisio Crystal  
2015L  
Piano Gloss Black



Rauvisio Crystal  
1968L  
Glossy Marble Tuscany



Rauvisio Crystal  
1910L  
Gloss Light gray

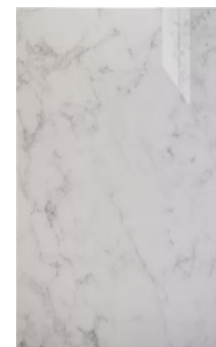

Rauvisio Crystal  
1970L  
Gloss Marble White



Rauvisio Crystal  
V2892  
Gloss White



Rauvisio Crystal  
1684L  
Mint Gloss



Rauvisio Crystal  
2407L  
Laguna Gloss



Rauvisio Crystal  
1972L  
Silver-plated wood



Rauvisio Crystal  
2410L  
Atlantico Matte



Rauvisio Crystal  
2408L  
Laguna Matte



Rauvisio Crystal  
1686L  
Smoky Gloss





# CONTACTS

---

## MAIN OFFICE

Ukraine, Kyiv  
Blvd. Vatslava Havela, 16

+380 44 500 5707

+380 99 461 06 96 (WhatsApp, Telegram, Viber)

export@viyar.ua

Mon-Fri: 8 a.m. – 5 p.m. (CET)

## POLISH OFFICE

Poland, Warszaw  
Ogrodowa 8, 05-850 Macierzysz

viyar@viyar.pl



VIYAR.EU

*Bel Visa*<sup>®</sup>

---

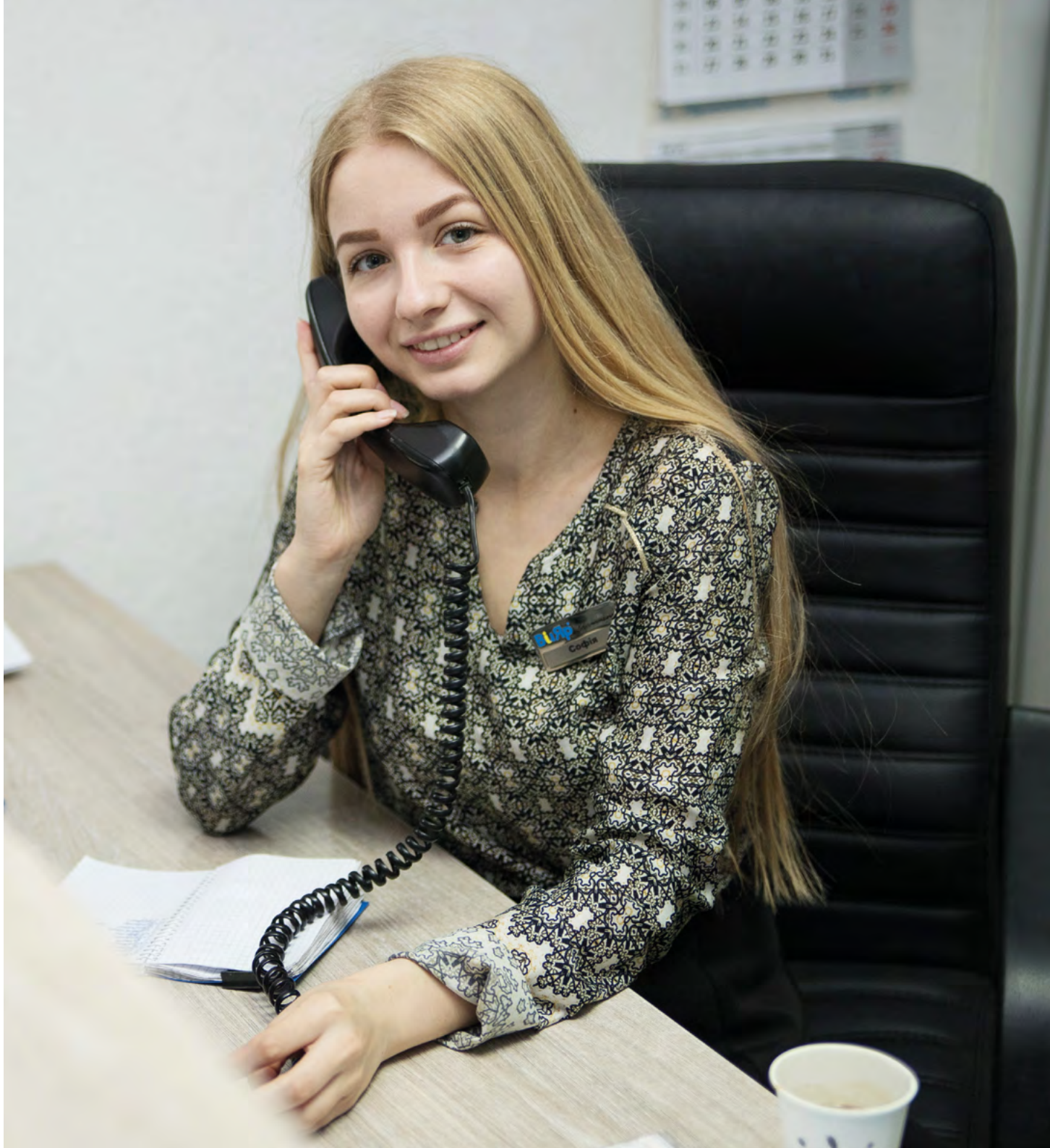

*We produce happiness...*