



NEUWOOD
LIVING

Item#: FG-NPL48DT-AB/CK/WT

ASSEMBLY INSTRUCTIONS

IMPORTANT! READ CAREFULLY AND RETAIN FOR FUTURE REFERENCE.

Naples Dining Table



Customer Service

customerservice@neuwoodliving.com

8:30a.m. – 5:00p.m. EST, M-F
Toll Free: 1-800-660-8840 (USA)
Fax: (973) 428-8026
www.neuwoodliving.com



Ver. 05/20/22

Please read instructions carefully and thoroughly before assembling. Check parts against the parts list to make sure you have all the parts needed for proper assembly. Familiarize yourself with the inventory of parts and the accompanying illustrations to ensure safe and proper assembly. Failure to tighten bolts may cause injury. Do not force components and overtighten the nuts during assembly. Improper assembly may result in serious personal injury.

DINING TABLE WEIGHT LIMIT: 250 LBS

PARTS LIST

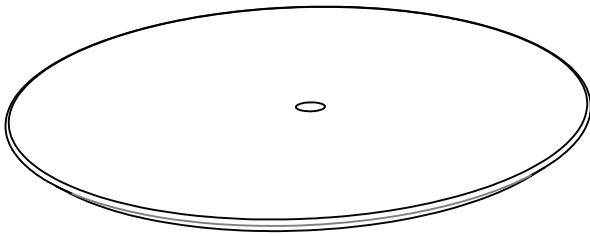

A Table Top (1pc)

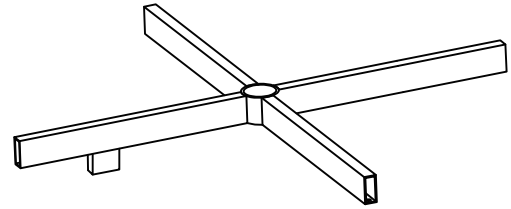

B Cross Brace (1 pc)

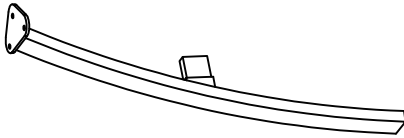

C Table Leg (4 pcs)



D Umbrella Cap (1pc)

HARDWARE LIST

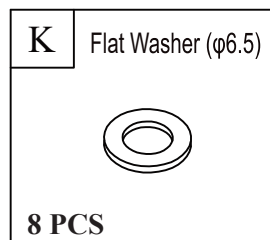
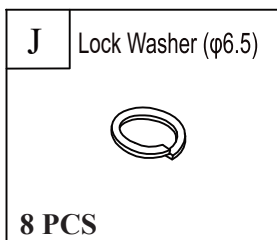
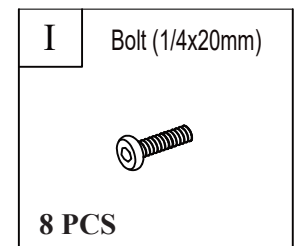
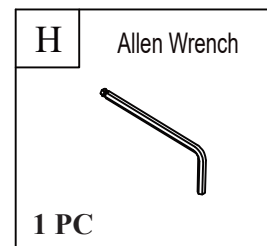
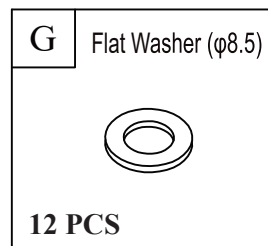
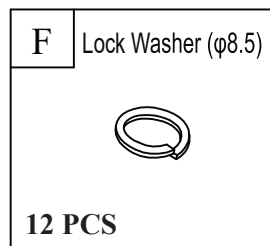
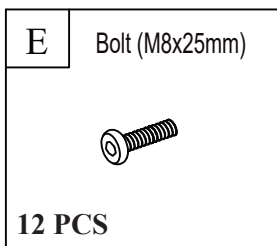

DINING TABLE ASSEMBLY INSTRUCTION

1

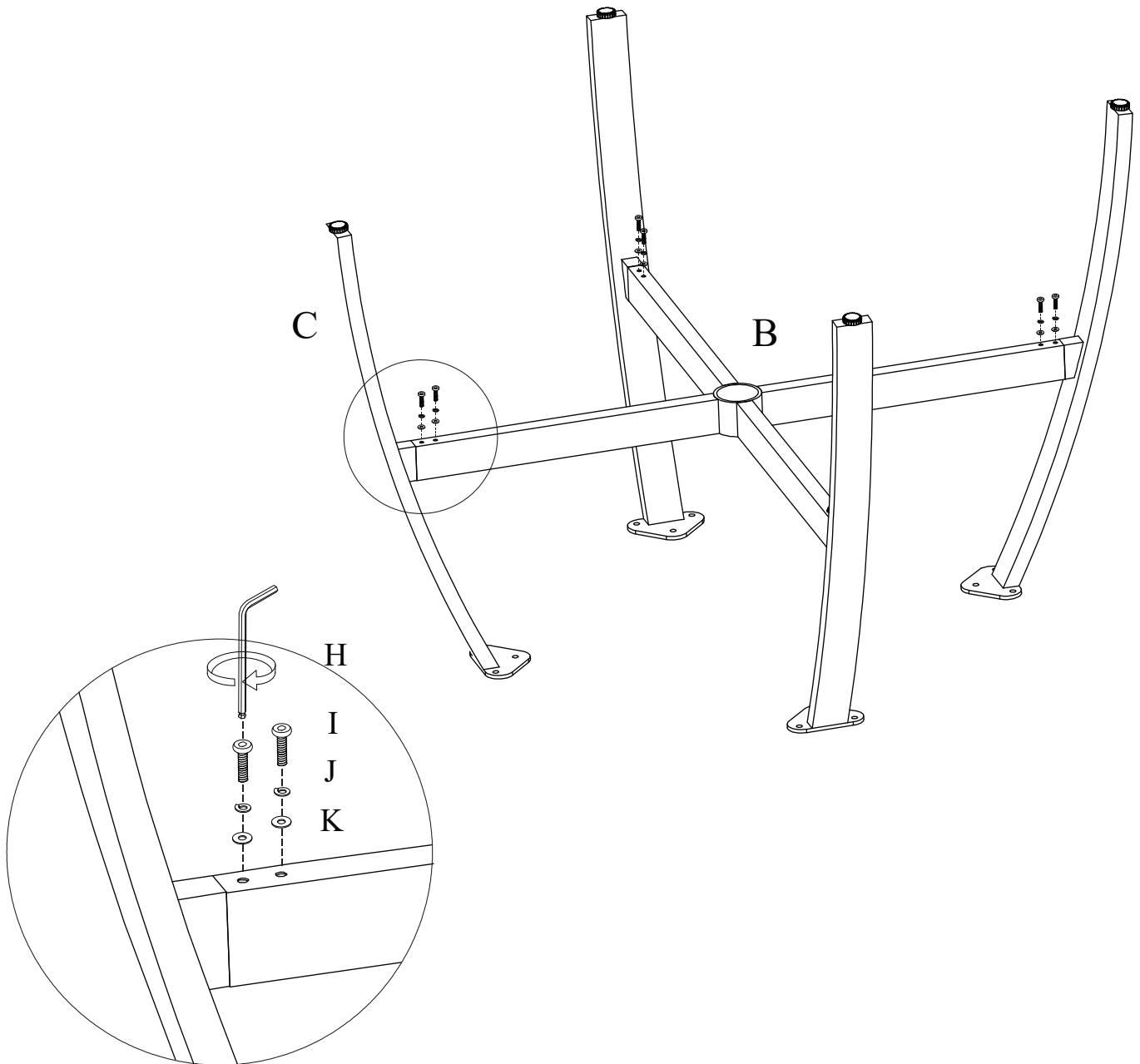

2

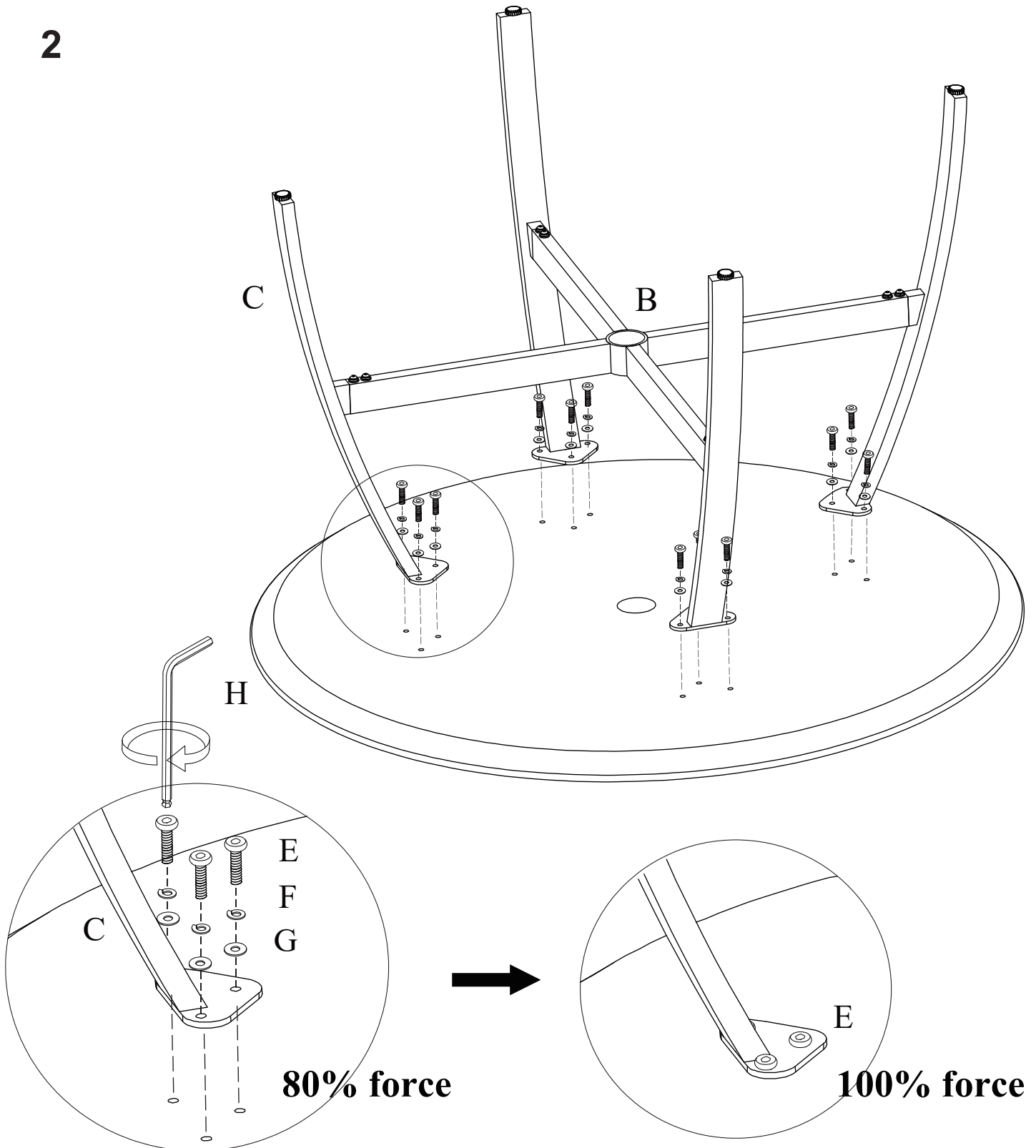

3

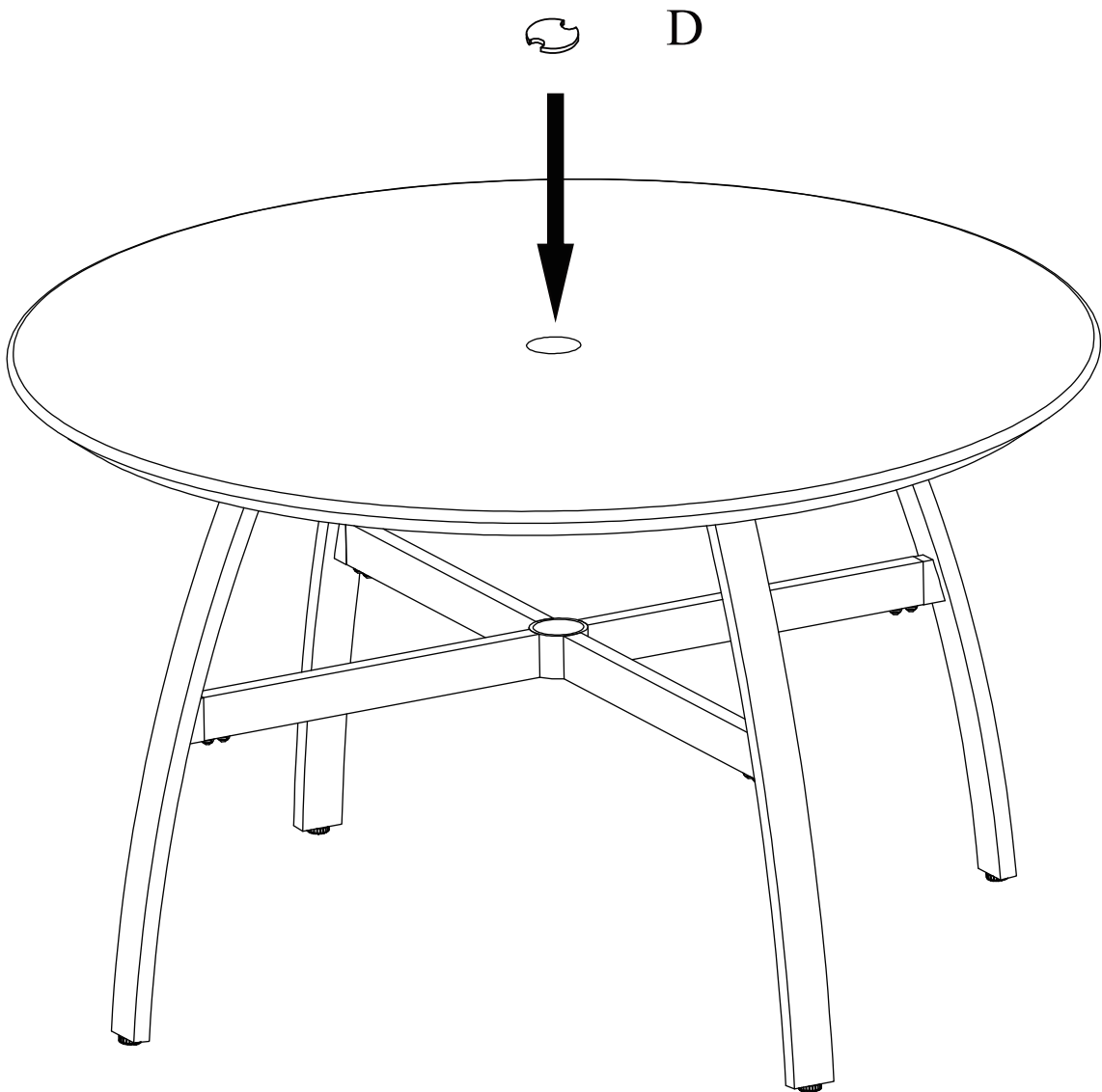



REPLACEMENT PARTS LIST

PART	REPLACEMENT PART#	DESCRIPTION
A	PF-FG-NPL48DT-A	Dining Table Top
B	PF-FG-NPL48DT-B	Dining Table Cross Brace
C	PF-FG-NPL48DT-C	Dining Table Legs
D	PF-FG-NPL48DT-D	Umbrella Cap
E~K	PF-FG-NPL48DT-HP	Dining Table Hardware Pack



We at Neuwood Living are confident in the quality and durability of our products so we are offering one of the best warranties in the industry. So long as Neuwood Living products are used as intended and not purposely abused, we will honor our unconditional warranty and help you get back to enjoying your Neuwood furniture for years to come. All Neuwood Living products come with a unique QR code which we use to facilitate our closed loop internal recycling program. Please use the QR code to register your products with us for warranty and Neuwood recycling purposes.

NEUWOOD LIVING® 10 YEAR WARRANTY

Neuwood Living® offers a warranty against any defects in Neuwood material for up to ten (10) years for residential use and three (3) years for commercial use from original date of purchase by the original purchaser and ten (10) years for residential use and three (3) years for commercial use on workmanship. We will replace any products the same or equivalent within this warranty period if there are defects to Neuwood material.

METAL FRAMES

Our metal frames are made from durable, non-corrosive rust-free aluminum and powdered coated in durable finishes. We warrant metal frames free from breaks or cracks to the welds and joints for five (5) years of residential use and two (2) years commercial use. Damage caused by improper assembly and exposure to sub-freezing temperatures are not covered. However, if you do run into any problems caused by misassembling and expansion of frozen water, please contact us and we will do our utmost to help solve your problem.

FINISH

The finishes on Neuwood material are made from durable acrylic-based paint and is warranted against peeling, cracking, or blistering for a period of two (2) years. Our powder-coat finishes on aluminum frames are warranted against peeling, cracking, or blistering for a period of two (2) years. Fading resulting from exposure to elements is normal and not covered. Stains as a result of chemical spills and certain food items are not covered. Slight fading of finishes due to sun exposure and marks from normal usage are normal.

CUSHIONS AND FABRICS (IF APPLICABLE)

Cushions and fabrics are warranted for a period of two (2) years from original date of purchase, against seams separating or tearing. Fading or discoloration resulting from exposure to the elements, chemicals, or from spills is not covered so please be careful when enjoying your Neuwood outdoor furniture and entertaining you guests with wine and fine dining.

WICKER (IF APPLICABLE)

All weather wickers are warranted for a period of two (2) years from original date of purchase against breaking, tearing or fading. Fading or discoloration resulting from chemicals or spills is not covered.

CERAMIC TILE TOP

All ceramic tops are warranted for a period of five (5) years from original date of purchase against defects in material and or workmanship. Breakage, discoloration, staining, and/or any other weather-related issues are not covered.

SHIPPING AND HANDLING

The manufacturer will pay shipping and handling charges within continental North America on warranty claims for a period of one (1) year from the original date of purchase. Shipping and handling charges after one (1) year are the consumer's responsibility. Shipments outside continental North America are not covered at any time or for any reason.

WARRANTY EXCLUSIONS

We will not cover under warranty, damages caused purposely by malicious abuse, so although Neuwood has superior durability when compared to other composite, polymer materials and even natural wood, please use the beautiful furniture accordingly. Our warranty also only covers products that are bought new from our Neuwood Living e-commerce retail store and our retail partners.

Warranty is to the original purchaser when items are purchased from one of our authorized retailers and is not transferable. Displays and/or Floor Models sold "AS IS" are not covered. All warranty claims must be submitted with a dated register receipt within the warranty period. Should replacement of the warranted item be unavailable, Foremost Home Inc. reserves the right to substitute items of our choice similar in style, color and quality. For quality control purposes and verification, we reserve the right to request photographs of the damaged item(s). The terms of this warranty are subject to change without notice. To obtain warranty service please contact Neuwood Living® Customer Relations Department toll free number at 1-800-660-8840 (USA) between the hours of 8:30 am and 5:00 pm EST, Monday thru Friday or email us at customerservice@neuwoodliving.com or visit our website at www.neuwoodliving.com.