

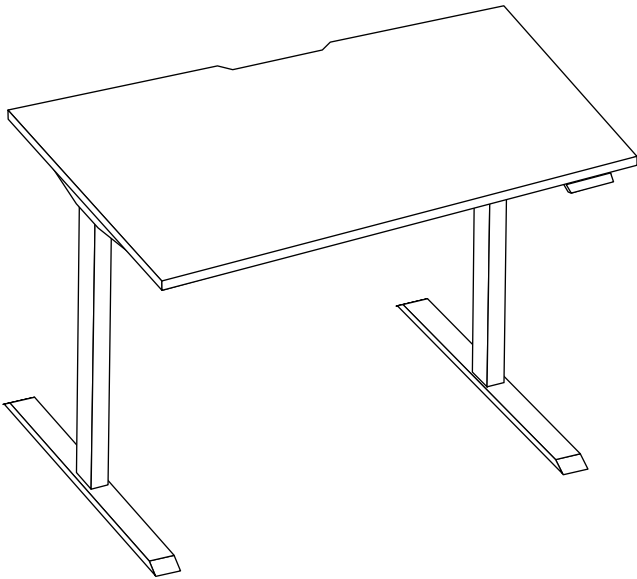

Life's short. Live longer.



Standing Desk

Owner's Manual for SD9

38"/48"/60" Desks

Welcome!

Congratulations on choosing the LifeSpan Workplace™ line of products. These products give you the opportunity to remain productive while taking care of yourself as you integrate movement with normally sedentary tasks.

The average American now spends eleven hours, five days a week, sitting, and burns one-hundred fewer calories each day than they did a few decades ago. Sitting for long periods slows your metabolism, reduces calories burned, and increases your risk for heart disease and diabetes.

Whether you plan on placing this product in a TV room, replace your desk at home or are adding another workspace in the office, LifeSpan Workplace™ products are a great way to add movement to an otherwise sedentary activity.

Before you assemble or operate your product, please read this manual thoroughly. Important information, including safety precautions, ongoing product maintenance, assembly instructions, and information on proper operation are included.

If you need to contact LifeSpan customer service, visit our website at www.LifeSpanFitness.com and select customer service. Complete the information requested and we will respond to your inquiry within one business day. In the United States and Canada you can also call 801-973-9993 and choose option 4.

Neither LifeSpan Fitness nor its representatives can accept responsibility for any damages or injury incurred as a result of information presented in this manual except under the terms of the product warranty.

About Your Standing Desk 4

- Specifications
- Warranty
- Exclusions and Limitations
- Registration
- Safety Tips
- Children and Pets
- Proper Grounding

Standing Desk Assembly 10

- Exploded View & Hardware
- Assembly Instructions

Standing Desk Operations 22

- Console Buttons
- Reset
- Standby
- Change Display
- Set Minimum Height
- Set Maximum Height
- Error Codes

About Your Standing Desk

Specifications

Frame

Frame Height	23.6" - 49.4" (60 - 125 cm)
Memory Keys	4
Standby Mode	Yes
Frame Weight Capacity	Dynamic Load 264.5 lbs (120 kgs)
Frame Weight	56.2 lbs (25.5 kgs)
Desktop Weight	38" Desktop = 38 lbs (17.2 kgs) 48" Desktop = 49 lbs (22.2 kgs) 60" Desktop = 60 lbs (27.2 kgs)

Console

Display	White LED
Readouts	Height adjustment levels
Buttons	Height adjustment, memory pre-sets

Warranty

Your LifeSpan standing desk comes with the following limited warranty valid in North America. If you are outside of this area contact your local authorized LifeSpan dealer.

WARRANTY	SD9
Frame	10 Years
Parts	2 Years
Labor	1 Year

LifeSpan warrants the equipment it manufactures is free from defects in materials and workmanship under normal use and services. The periods above are based on the date of purchase. During these periods, LifeSpan will replace defective parts. Free labor is included on all parts that are not normally assembled or replaced by the customer within the labor period.

If within the time frames specified above, any part fails to operate properly, login to our website at www.LifeSpanFitness.com, click on "Customer Service" and complete the form to request assistance or call 801-973-9993 option 4 for a Customer Service Agent (please note that certain kinds of service should only be performed by a qualified service technician).

LifeSpan reserves the right to make changes and improvements to our products without incurring any obligations to similarly alter any product purchased. In order to insure our product warranty and to ensure the safe and efficient operation of your LifeSpan product, only authorized parts can be used. The warranty is void if any parts other than those provided by LifeSpan are used.

About Your Standing Desk

Exclusions and Limitations:

- This warranty does not apply to any defects caused by negligence, misuse, improper assembly, or maintenance, accident, or “act of God.”
- This warranty does not apply to discoloration of paints or plastics.
- LifeSpan shall not be responsible for incidental or consequential damages.
- This warranty is non-transferable from the original owner.

Registration

You must register your LifeSpan product before a warranty claim can be processed. To complete your registration online go to www.lifespanfitness.com/support/registration. Completing the product registration within 60 days of delivery is necessary to activate the warranty, as the warranty will not be valid unless the registration is properly completed within this timeframe.

Safety Tips While in Use

- Make sure no obstacles are in the desk's path.
- Make sure the desktop is not touching any walls.
- Make sure all cords are appropriate length to accommodate the change in height.
- Keep all electrical components away from liquids.
- Do not sit or stand on the desk frame.
- Do not crawl or lie under the desk frame.
- Do not place any objects taller than 20" underneath the desk.
- Do not open any of the components - the Legs, Control Box, or Switch. There is a danger of electric shock.
- In the event of a power outage or the power cord is unplugged, a manual reset may be necessary - see OPERATIONS section.
- This height adjustable desk has electric motors and is designed for use in dry work areas only.
- The desk height is adjustable so that it can be positioned at the most ergonomically suitable height.
- Any other use is at user's risk.
- Under no circumstances does the manufacturer accept warranty claims or liability claims for damages caused from improper use or handling of the standing desk.

Children and Pets

- Keep children from playing on and around your standing desk at all times.
- When in use children and pets should be kept at least 10 feet (3m) away.
- Keep children away from electric height-adjustable desks, control units and handsets. There is a risk of injury and electric shock.

Note: Read all instructions and save for future reference.

About Your Standing Desk

Proper Grounding

LifeSpan equipment must be grounded. Improper connection of the equipment's grounding conductor can result in the risk of electric shock. Check with a qualified electrician or service person if you are in doubt as to whether the outlet is properly grounded. Do not modify the plug provided with the product or use a ground plug adapter to adapt to a non-grounded outlet. If the plug will not fit in the outlet, have the proper outlet installed by a qualified electrician.

Power Cord Options

This standing desk should only be used with the proper power cord and power outlet. Several power cord options (shown below) are available from LifeSpan. We do our best to include the correct power cord with the standing desk for your area. In the event that the correct power cord is not included in the packaging please contact your local distributor.

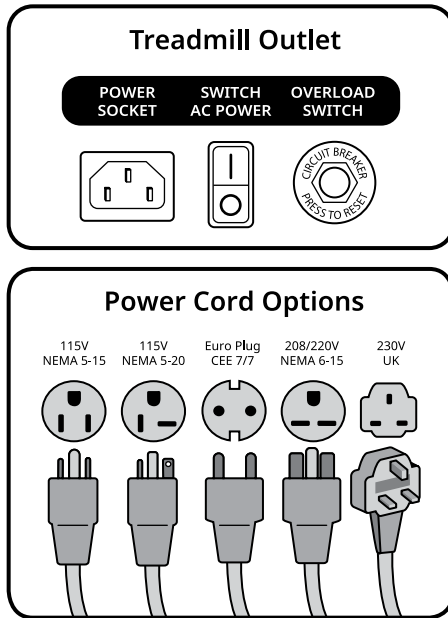

⚠ DO NOT use extension cords between the standing desk and power outlet.

⚠ DO NOT plug into a GFI outlet or circuit as it may trip the breaker.

SD9 Desk Assembly

At LifeSpan we strive to make our equipment easy to assemble and start using. Parts that can be pre-assembled are always assembled and tested on the product line.

Prior to starting the assembly process, take all the parts out of the box, remove plastic bags and lay everything out on the floor to become familiar with the components.

Since your desk is a heavy piece of equipment, it is recommended that you use two people during assembly and follow these assembly instructions to reduce any problems that may occur.

Desktop Ships Separately

Tools Included

- #4 Allen Wrench
- #5 Allen Wrench

Tools Needed

- Power Drill Recommended
- Screwdriver

Before You Begin

Lay out all components and hardware to ensure that you have everything listed on this page.

Hardware Included

Item#	Part Description
1	Leg
2	Foot
3A	Frame End
3B	Frame End
4	Center Rail

Item#	Part Description
5	Side Bracket
6	Motor Control Unit
7	Console
8	Power Cord

Item #	Qty.	Part Description
9	18	M6x10 Machine Screws
10	14	M6x16 Machine Screws
11	6	M5x16 Wood Screw
12	2	Cable Clip
13	4	M6x40 Machine Screws
14	10	M6x15 Machine Screws

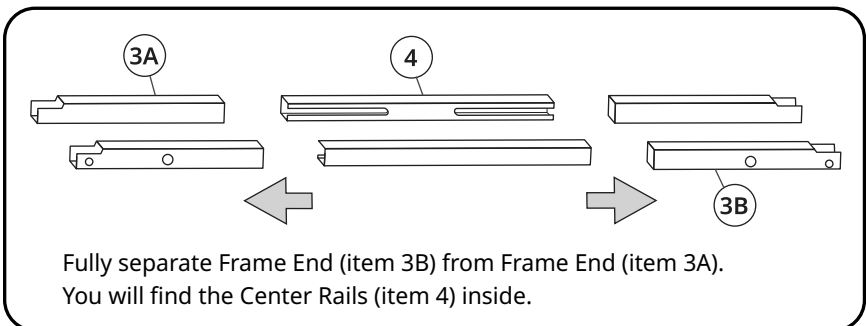
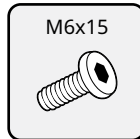
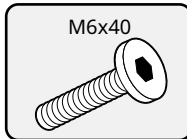
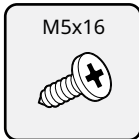
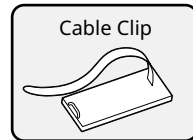

SD9 Desk Assembly

Step 1: Attach Frame Ends to Legs

- A. Place one of the Legs (item 1) into the Frame End (part 3A and 3B) ensuring that the bar (arrow) is on "top" in relation to the Leg (Item 1).
- B. Line up the holes on the Leg (item 1) with the holes on the Frame End (part 3A and 3B)
- C. Using the supplied Allen Wrench, insert four (4) M6x10 Machine Screws (item 9) through the holes in the Frame End (item 3A and 3B), going into the Leg (item 1) and start to tighten with just a few turns. After all four (4) M6 x10 Machine Screws (item 9) are inserted, tighten all four (4) screws.
- D. Do the same for the other Leg (item 1) and the Frame Ends (item 3A and 3B).

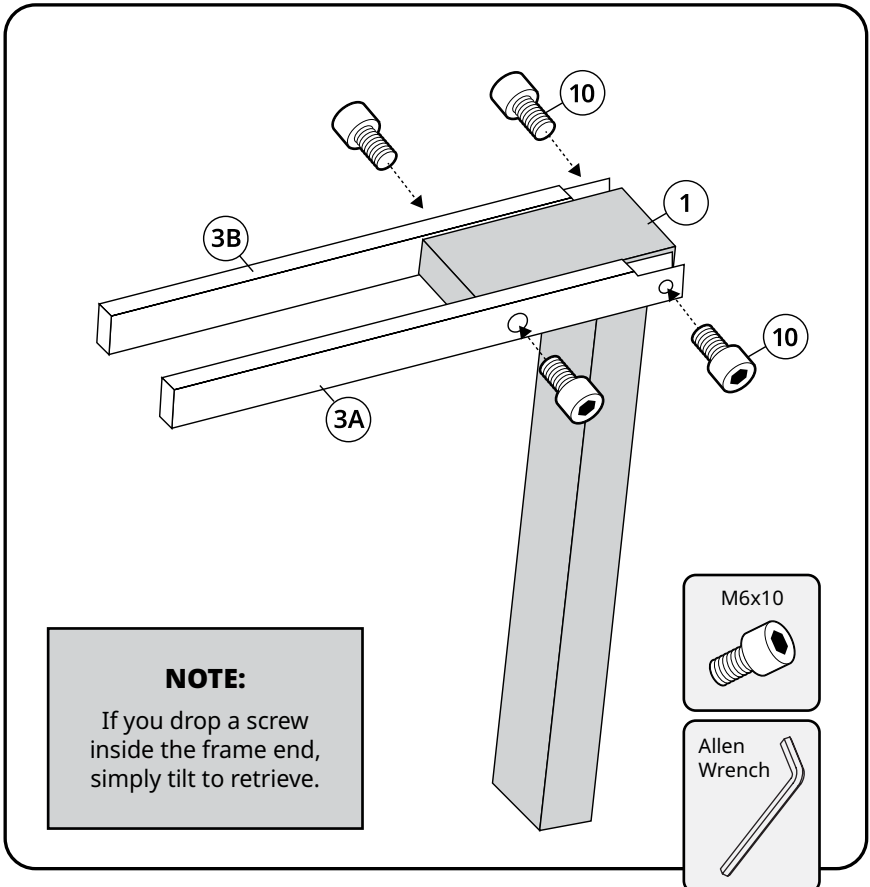

Step 2: Attach Side Bracket

- A. Place the Side Bracket (item 5) onto the Frame End (item 3A and 3B). Insert two (2) M6x40 Machine Screws (item 13) through the two (2) holes and into the Frame Ends (item 3A and 3B). Using the supplied Allen Wrench, rotate each screw just a few turns. After both M6x40 Machine Screws are inserted, tighten both screws.
- B. Do the same for the other Frame End/Leg.

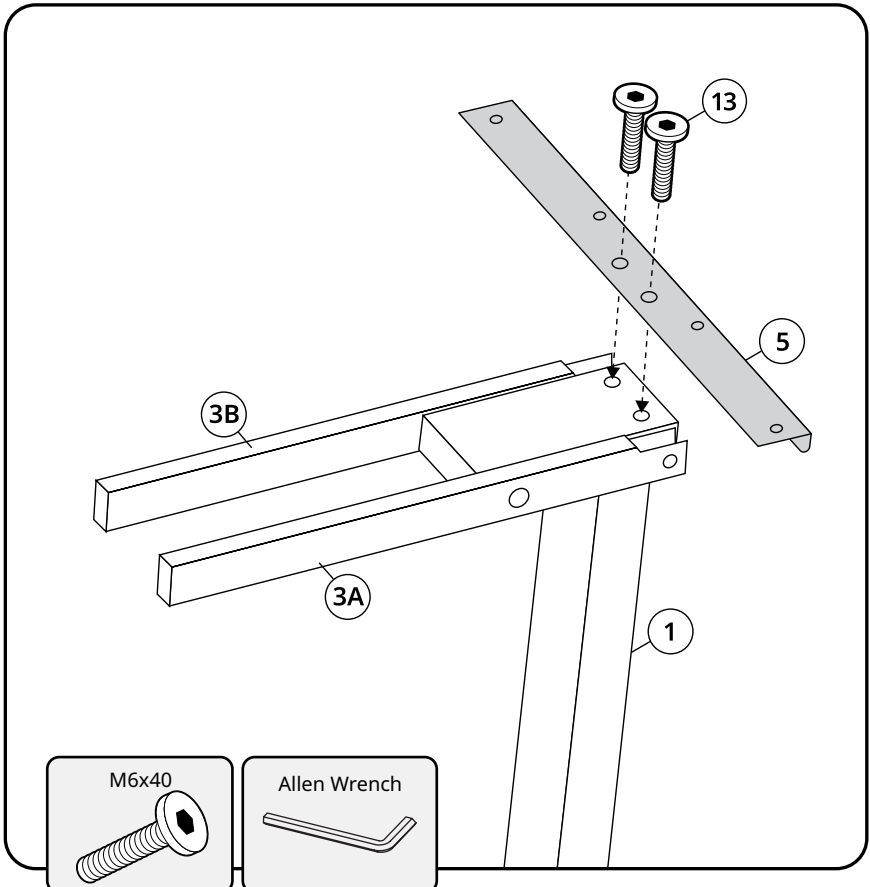

SD9 Desk Assembly

Step 3: Attaching Frame to Desk

- A. Place the assembly completed in Step 3 on the desktop and line up the furthest holes on the ends using two(2) M6x15 Machine Screws (item 14).

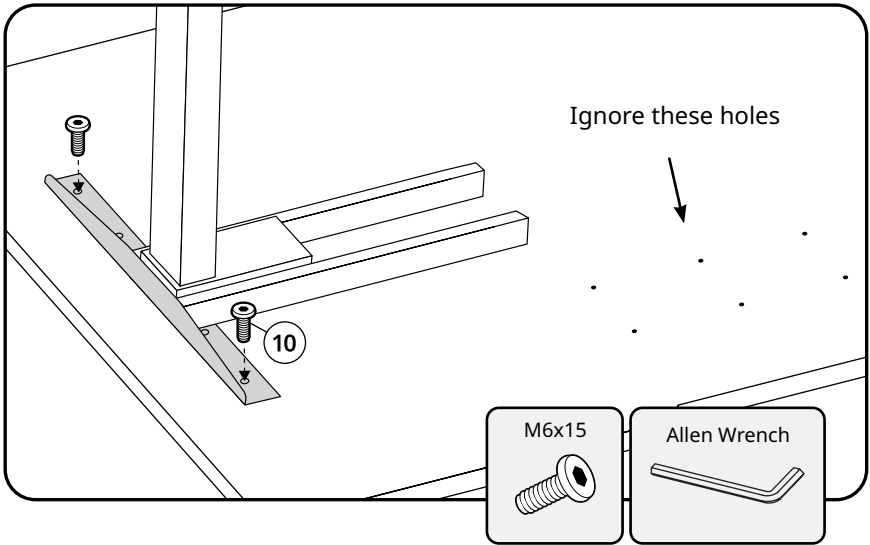

- B. Insert the two Center Rails (with the cut facing inward) (part 4) to the Frame End (item 3A and 3B).

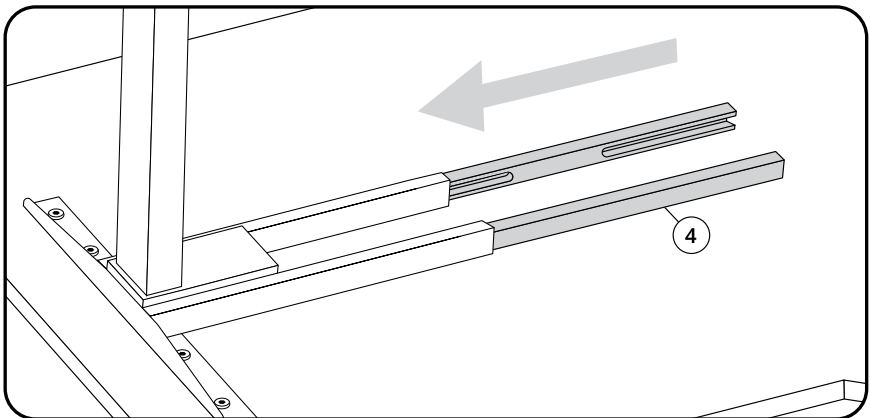

- C. Insert the other assembly completed in Step 3 to the Center Rails (item 4) and line up the furthest holes on the ends using two(2) M6x15 Machine Screws (item 14).

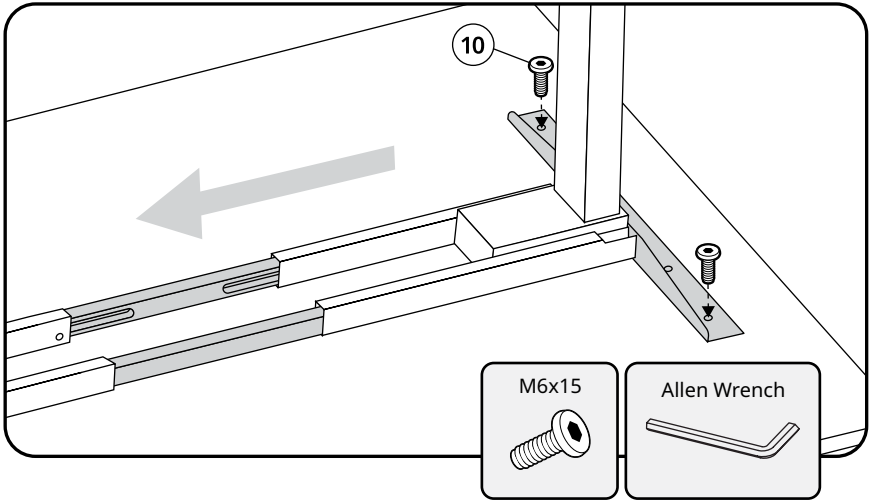

- D. Slide the Center Rails (item 4) to the middle position of the desktop. Finger tighten the eight(8) M6x10 Machine Screws (item 9). Check to be sure the screws are tightening against the center rails. Tighten all machine screws.

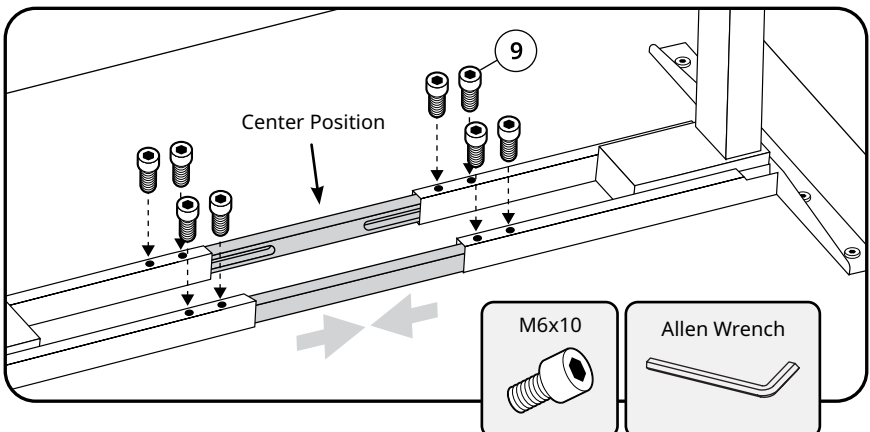

SD9 Desk Assembly

Step 4: Attaching the Feet

- A. Insert the Feet (item 2) to the Legs (item 1) using eight(8) M6x16 Machine Screws (item 10). Repeat on other leg.

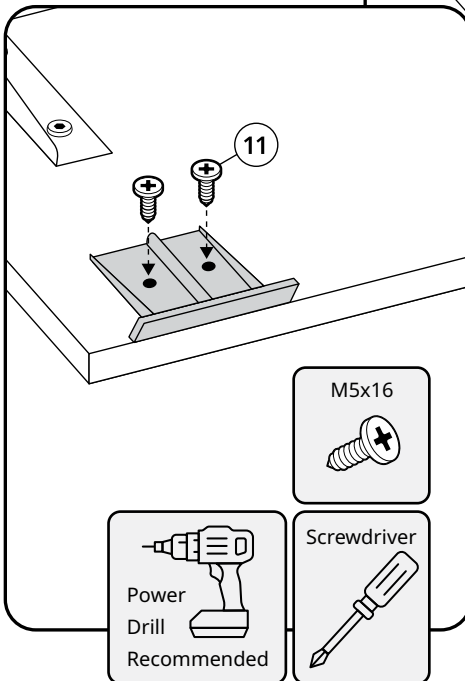
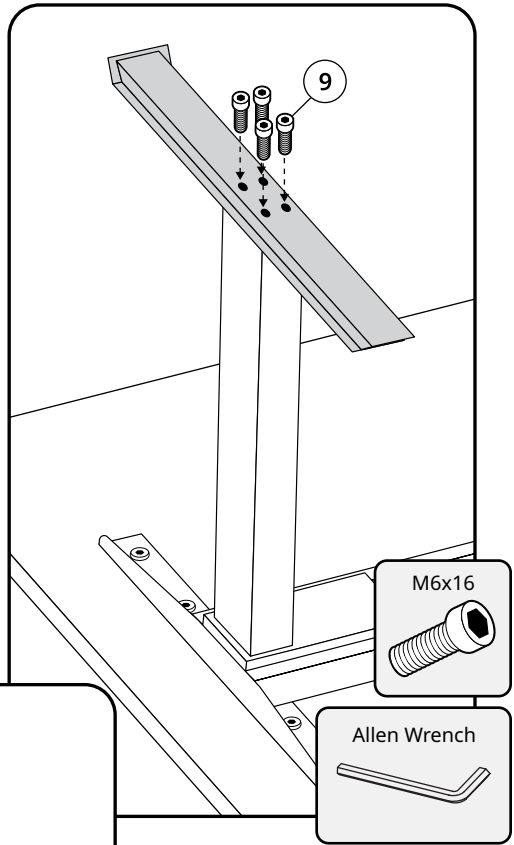

Step 5: Attaching the Console

- A. Position Console (item 7), mark and predrill holes.
- B. Attach the console so the front of the console is flush with the front desktop edge (or increase up to 1/8"). Attach to the desktop using two(2) M5x16 Wood Screws (item 11).

Step 6: Attaching Motor Control Unit

- A. Place the Motor Control Unit (item 6) into position. Mark the hole locations onto the desk and drill holes matching the depth of the M5x16 Wood Screws.
- B. Place Control Box (item 6) back into position and screw into place with the two wood screws.

Note: Make sure the Motor Control Unit lies flat on the desktop when attaching. Failure to do this may result in an error code.

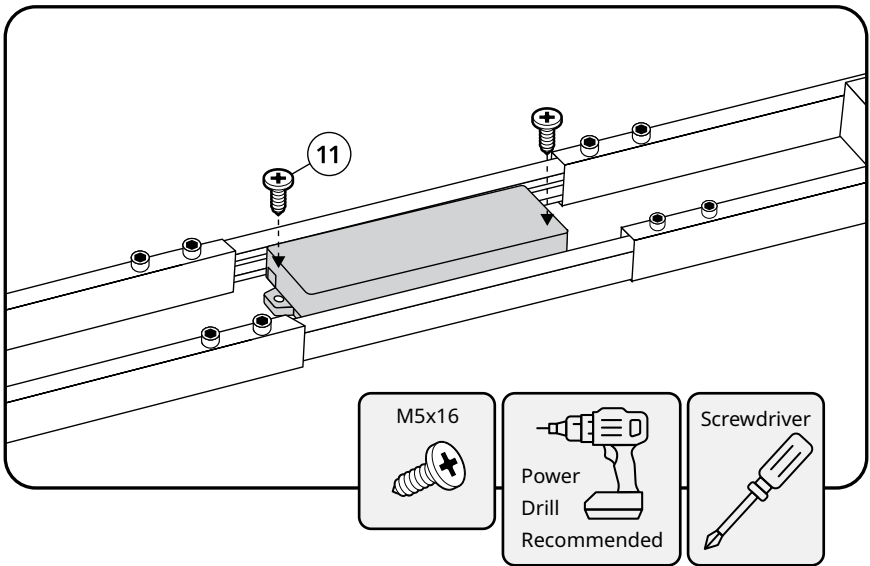

SD9 Desk Assembly

Step 7: Connecting the Cables

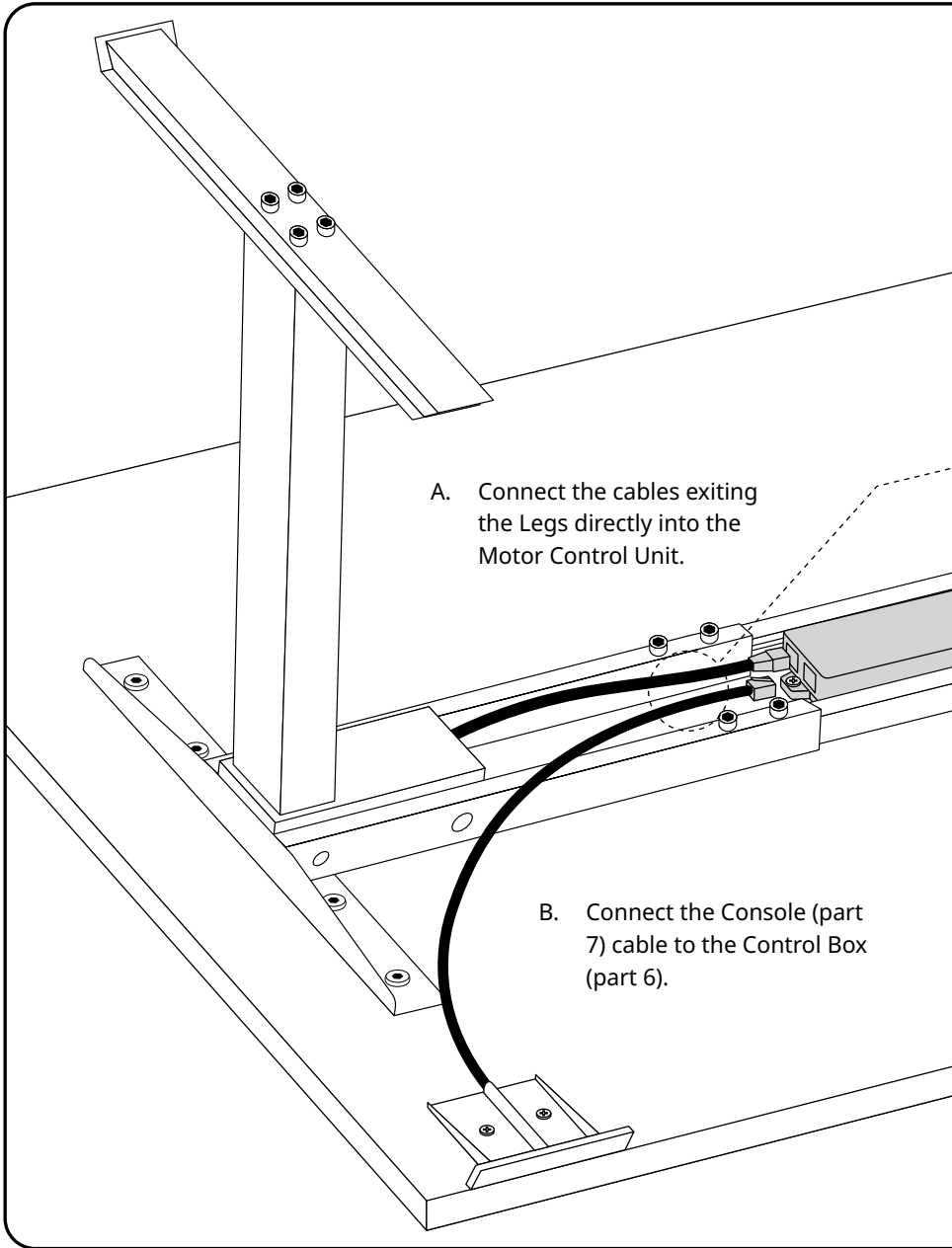

D. Use the adhesive backed Cable Clips (part 13) to secure the cables so they do not sag.

C. Connect the Power Cord (part 8) to the Motor Control Unit (part 6).

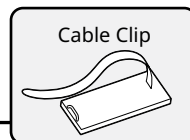
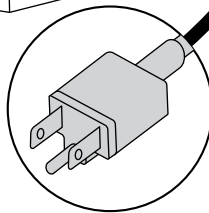

SD9 Desk Assembly

Step 8: Turn Upright

- A. Turn the assembled desk right-side up. With at least two people, grab the Desk Base (not the desktop) and turn the desk right-side up. Adjust the pre-installed glides on the feet as needed.
- B. Plug the power cord into an outlet

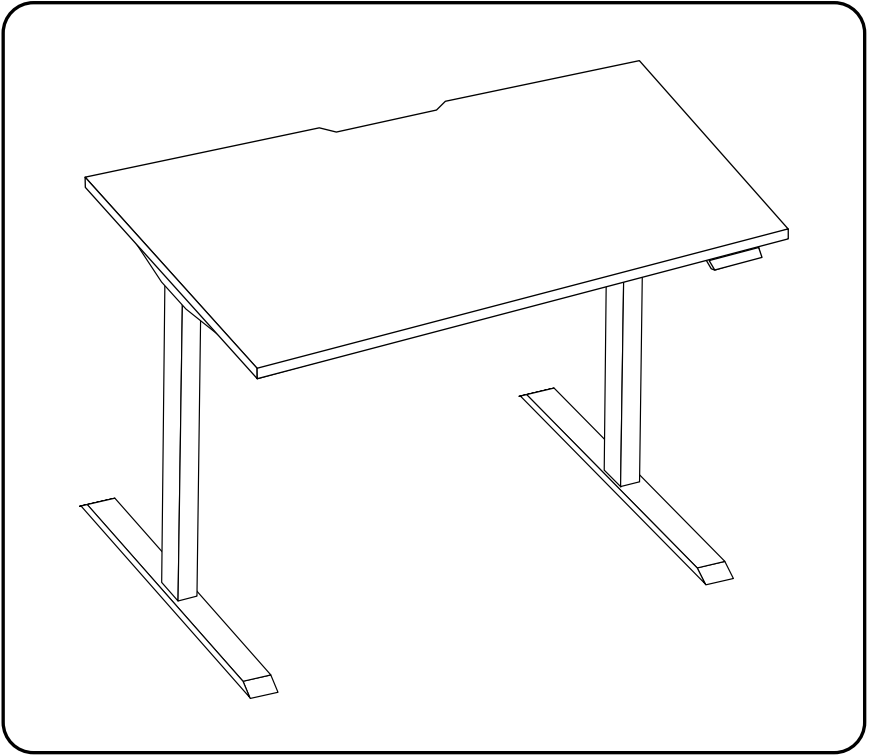

SD9 Desk Operations

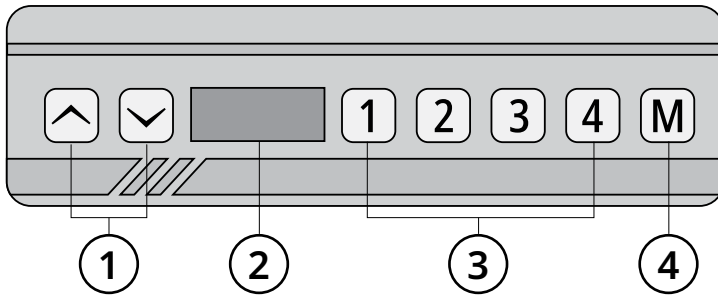

Console Buttons

1. **▲ ▼** : Increases or decreases desk height.
2. **Display**: Shows height range.
3. **Memory Keys**: Pre-set buttons remember 4 different heights.
4. **M**: Sets desk to desired height. Adjust desk height. Hold 'M' button down and the display will flash for 5 seconds. Press any memory key and this will store the position to this key.

Reset

A reset needs to be done when RST appears in the display.

Press the **▲** and **▼** arrow keys at the same time until the display shows normal digits with a buzz sound.

Standby Mode

After the motor stops working for 30 seconds the display will turn off. Press any key, except the M key, to resume running.

Change Display

Press and hold the M key and 3 key simultaneously to switch the display unit (cm & inch).

Set Minimum Height

While holding down the M and 1 key the display will blink while still showing the current height. Press the **▲** and **▼** buttons to adjust the desk to the minimum desired height. Press M + 1 to complete the setting.

Set Maximum Height

While holding down the M and 2 key the display will blink while still showing the current height. Press the **▲** and **▼** buttons to adjust the desk to the maximum desired height. Press M + 2 to complete the setting.

Error Codes

Error Code	Description	Handling Steps
HOT	Overheat- System detects the action by not following the rated duty cycle and prevents it from overheating.	Stop operating until cooled off.
E01	The cable of motor 1 is not connected	1.Check whether the cable of motor 1, or motor 2 is properly connected to the motor control unit. 2. Check that the cable of motor 1, or motor 2 is intact.
E02	The cable of motor 2 is not connected	3. After trouble shooting, press any key clear the error code to resume running (except M key)

SD9

Standing Desk

LifeSpan Fitness

785 West 1700 South Suite 1

Salt Lake City, UT. 84104

Phone: 801.973.9993

www.LifeSpanFitness.com

2023 Version 2.0