



Life's short. Live longer.

Smart Console for
Office Bikes and Treadmills

Owner's Manual for SC120-2022

Congratulations on Choosing LifeSpan Workplace™ line of products.

These products give you the opportunity to remain productive while taking care of yourself as you integrate movement with normally sedentary tasks.

The average American now spends eleven hours, five days a week, sitting, and burns one-hundred fewer calories each day than they did a few decades ago. Sitting for long periods slows your metabolism, reduces calories burned, and increases your risk for heart disease and diabetes.

Whether you plan on placing this product in a TV room, replace your desk at home or are adding another workspace in the office, LifeSpan Workplace™ products are a great way to add movement to an otherwise sedentary activity.

Before you assemble or operate your product, please read this manual thoroughly. Important information, including safety precautions, ongoing product maintenance, assembly instructions, and information on proper operation are included.

If you need to contact LifeSpan customer service, call (801-973-9993 and choose option 4.

Neither LifeSpan nor its representatives can accept responsibility for any damages or injury incurred as a result of information presented in this manual except under the terms of the product warranty.

Welcome

Getting Started..... 6

Warranty

Setup With Your Existing Desk 8

Hardware

Install Safety Key

Treadmill to Desk Setup

Bike to Desk Setup

Button Functions

Specifications

Treadmill/Bike Operation 18

Quick Start

Initial Setup Mode

Table of Contents

Using With Your LifeSpan Electric Adj. Desk.....	21
Additional Functions For a LifeSpan Desk.....	22
Console Desk Functions	
Preset Desktop Height Settings	
Install the Desktop Ht. Adj. Cable	
Treadmill/Bike Desk Operations	26
Quick Start	
Initial Setup Mode	
Specifications For a LifeSpan Desk.....	28
Preset Desktop Height Adjustment	
Custom Settings.....	30
Treadmill Desk Troubleshooting	32
Bike Desk Troubleshooting	34

Getting Started

Warranty

Your LifeSpan treadmill/bike desk comes with the following limited warranty valid in North America. If you are outside of this area contact your local authorized LifeSpan dealer.

Parts	2 Years
-------	---------

LifeSpan warrants the equipment it manufactures is free from defects in materials and workmanship under normal use and services. The periods above are based on the date of purchase. During these periods, LifeSpan will replace defective parts. Free labor is included on all parts that are not normally assembled or replaced by the customer within the labor period.

If within the time frames specified above, any part fails to operate properly, call 801-973-9993 option 4 for a Customer Service Agent (please note that certain kinds of service should only be performed by a qualified service technician).

LifeSpan reserves the right to make changes and improvements to our products without incurring any obligations to similarly alter any product purchased. In order to insure our product warranty and to ensure the safe and efficient operation of your LifeSpan product, only authorized parts can be used. The warranty is void if any parts other than those provided by LifeSpan are used.

Exclusions and Limitations:

- This warranty does not apply to any defects caused by negligence, misuse, improper assembly, or maintenance, accident, or "act of God."
- This warranty does not apply to discoloration of paints or plastics.
- LifeSpan shall not be responsible for incidental or consequential damages.
- This warranty is non-transferable form the original owner.

Setup With Your Existing Desk

Hardware

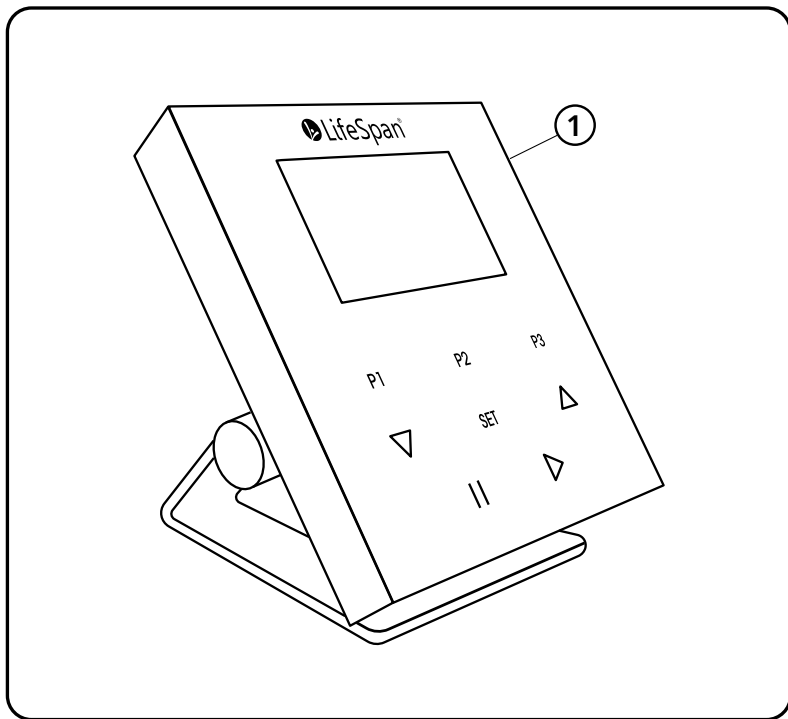

Setup With Your Existing Desk

Item#	Qty.	Part Description
1	1	SC120-2022 Console
2	2	#6 x 1/2" Phillips Screw
3	1	Double Sided Tape
4	1	Safety Key Unit & Cable
5	3	Cable Ties
6	1	Velcro Strap
7	1	9 Pin Data Cable
8	1	Desktop Ht. Adj. Cable

#6 x 1/2"
Screw x2



Double
Sided Tape



Safety
Key Unit



Cable Ties
(x3)



Velcro
Strap

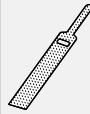

9 Pin
Data Cable



Desktop
Ht. Adj.
Cable



Setup With Your Existing Desk

Install the Safety Key

- A. Get the Safety Key Unit(4) and attach the Double Sided Tape(3) to the side of the Safety Key Unit that will be against the desk. Position toward the front of the desk where the treadmill or bike will be used, and tack in place.
- B. Fasten to the desk with the two #6 x 1/2" Phillips Screws(2).
- C. Position the cable for the Safety Key Unit in the center of the desk and attach with the Cable Ties(5). You can also use the Velcro Strap(6) to help bundle and organize your cables.
- D. Check to see that the end of cable for the Safety Key Unit is plugged into the back of the Console.

Setup With Your Existing Desk

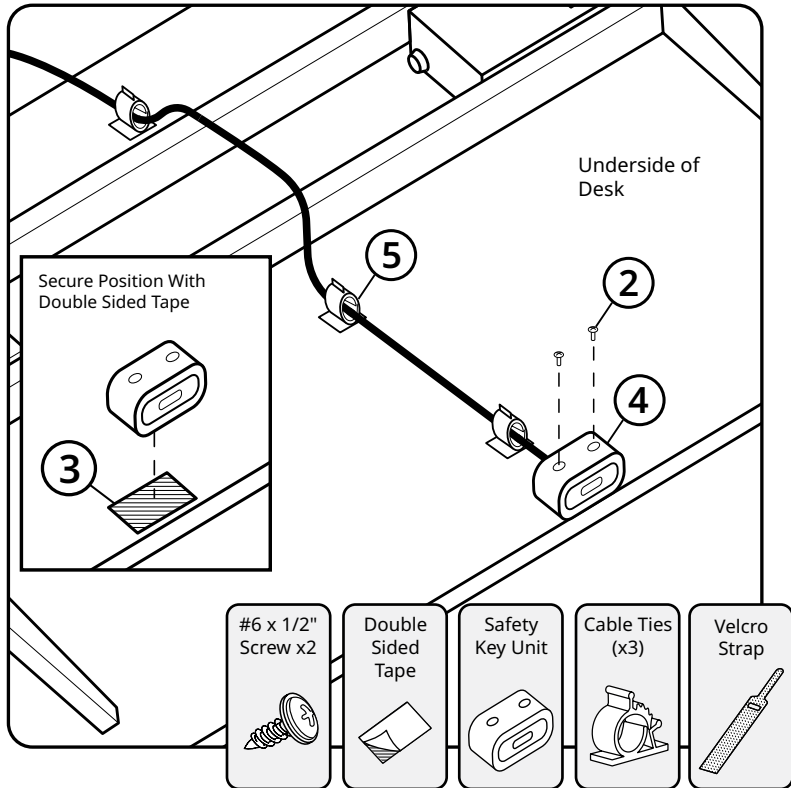

Setup With Your Existing Desk

Treadmill to Desk Setup

- A. Position the pre-assembled treadmill as shown below.
- B. Lift the rear of the treadmill and roll it forward under the desk. Once in position, stand on the treadmill and see if your feet are too close to the hood. If so, reposition the treadmill further under the desk.

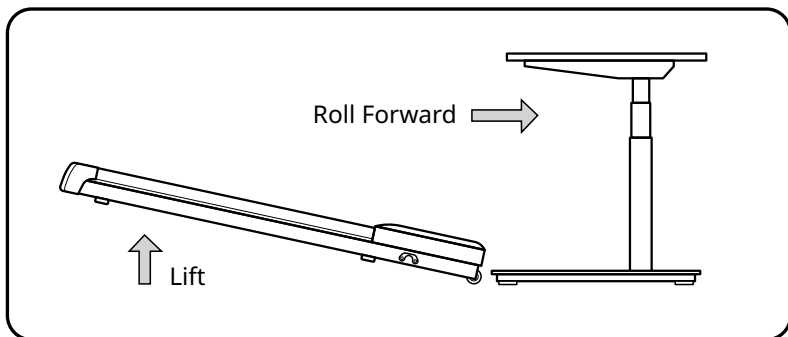

Setup With Your Existing Desk

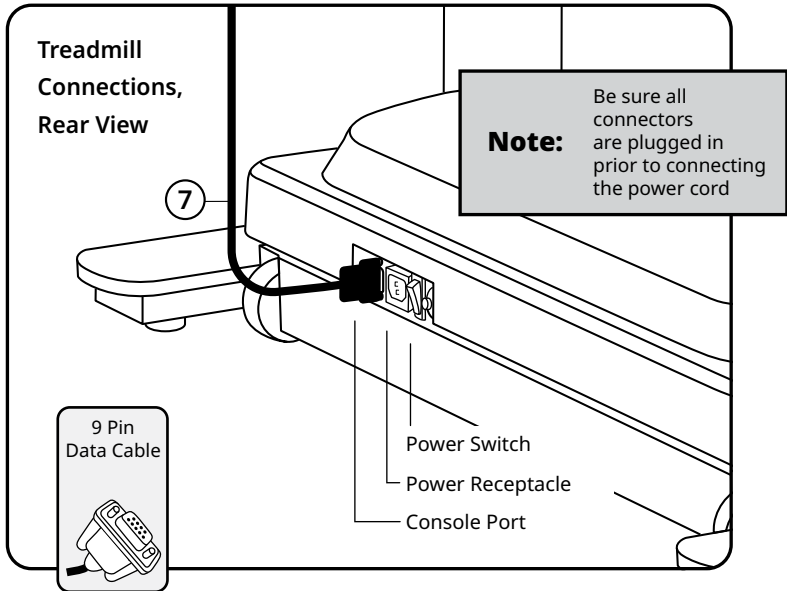

- C. Connect the 9 Pin Data Cable(7) from the Console into the treadmill Console Port and tighten the thumb screws.
- D. Plug the Power Cord into the treadmill Power Receptacle and into a wall outlet.
- E. Turn the treadmill Power Switch on.

Setup With Your Existing Desk

Bike to Desk Setup

- A. Position the pre-assembled bike as shown below.
- B. Tilt the front of the bike up and roll it forward under the desk to the desired position.

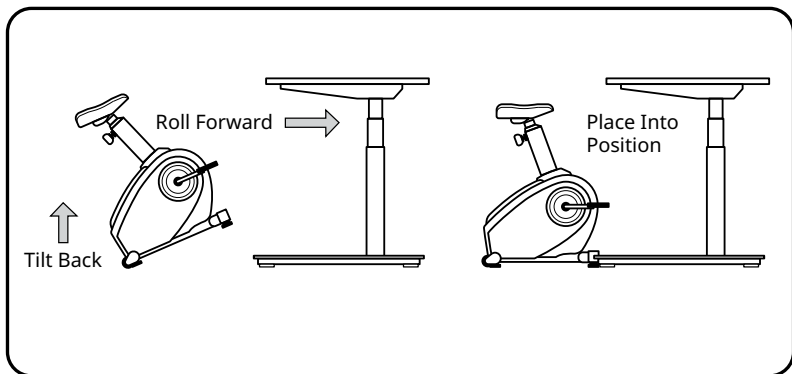

Setup With Your Existing Desk

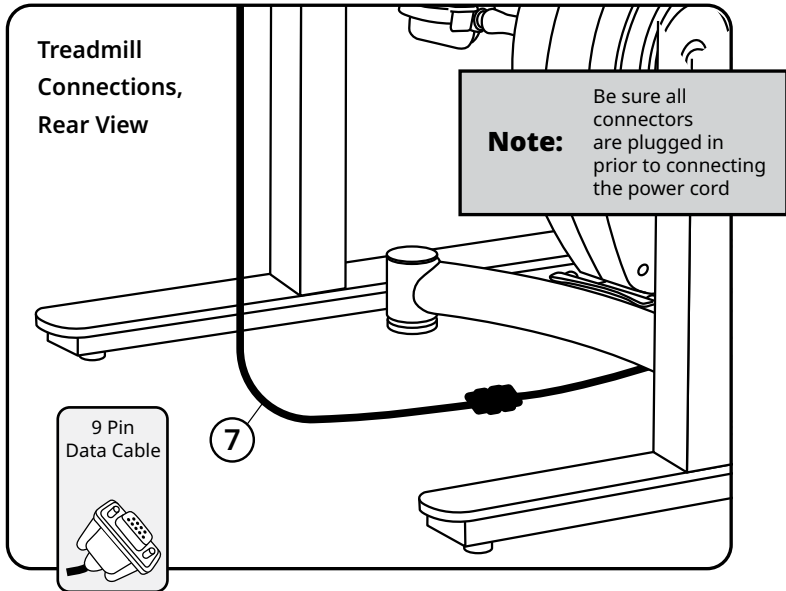

- C. Connect the 9 Pin Data Cable(7) from the Console into the Bike Data Cable and tighten the thumb screws.
- D. Plug the Power Cord from the back of the bike to a wall outlet.

Setup With Your Existing Desk

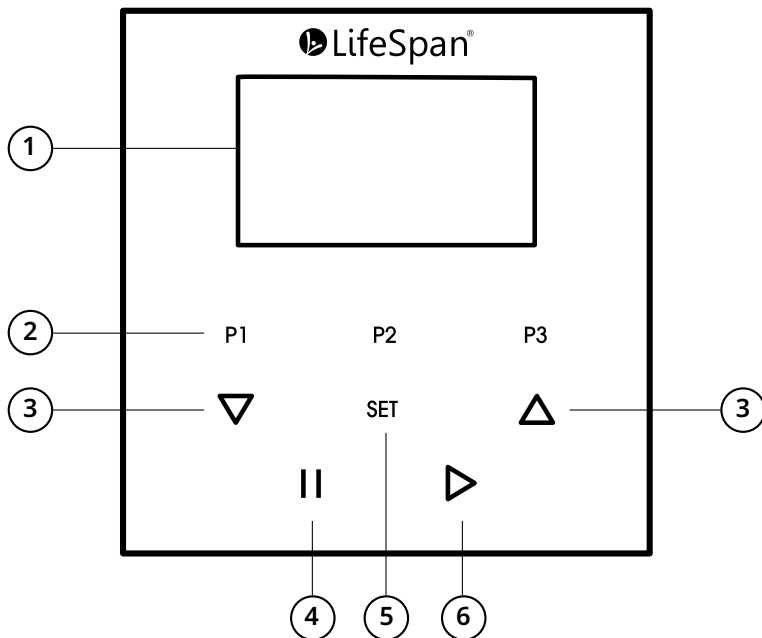

Note: Default setting is 4 mph (6.4 kph). Can be changed to max speed of 2 mph/ 3.2 kph in personal settings

Setup With Your Existing Desk

1. 3.5" Display Screen
2. Preset buttons: Preset treadmill speeds. The default values for preset speeds are P1=0.4 mph, P2=1.2 mph, and P3=2.0 mph.
3. Up and Down Arrows: When using treadmill will increase or decrease speed. When using the desk bike, will increase and decrease pedal resistance.
4. Pause/Stop Button: Used to pause/stop the treadmill, or to pause bike program. Press again and the summary screen of your exercise data will show. This is also used to back out of any current screen you are on. When you press and hold down it will turn off the console.
5. Set: Tap the Set button to access Personal Settings. Press and hold the Set button to access initial setup screen.
6. Start Button: Press to start the treadmill or to initiate bike tracking.

Readouts	Time, Date, Speed(Treadmill/Resistance(Bike)), Distance, Exercise Time, Calories, Steps, Speed (Bike), Summary
Display	3.5" 320x480 pixel TFT
Bluetooth	Yes
Buttons	Speed or Resistance Preset, Increase/Decrease Speed or Resistance, Pause/Stop, Start

Treadmill/Bike Operation

Quick Start

- Make sure the safety key is set in place.

Note:

The display will show a warning image if the Safety Key is not engaged. Please make sure that the Safety Key is fully engaged. It is possible the display will not show a warning when just partially engaged.

- Press and hold the Start Button to turn on console screen.
- Enter settings for Initial Setup Mode.
- Press and hold the Start Button for 3 seconds to start the treadmill. If using a desk bike this will start recording your exercise data).
- Use the up and down arrows to adjust speed or pedal resistance.
- Press the Pause/Stop button to stop treadmill belt, and pause the exercise program.
- Press the Pause/Stop button to exit the program and to see your exercise summary.
- Press the Pause/Stop button to exit exercise summary and enter standby mode.
- Press and hold the Pause/Stop button to turn off the Console.

Treadmill/Bike Operation

Initial Setup Mode

The first time you turn on the console you will need to set the calendar, time, and some basic physical information about yourself.

Year: Use the up and down buttons to select year. Press Set.

Month: Use the up and down buttons to select month. Press Set.

Day: Use the up and down buttons to select day. Press Set.

Time: Use the up and down buttons to select time. Press Set.

Units: Use the up and down buttons to select Imperial or Metric. Press Set.

Age: Use the up and down buttons to input your age. Press Set.

Weight: Use the up and down buttons to input your weight. Press Set.

You will exit initial setup mode and see the Standby Screen showing the date and time.

If you ever need to change any of the settings for Initial Setup, press and hold the Set Button.

Using With Your LifeSpan Electric Adjustable Desk

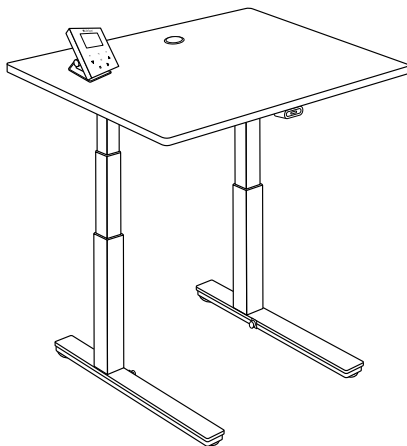

Please refer to the SD120 Electric Adjustable Desk manual
for assembly and console connection instructions

Additional Functions For a LifeSpan Desk

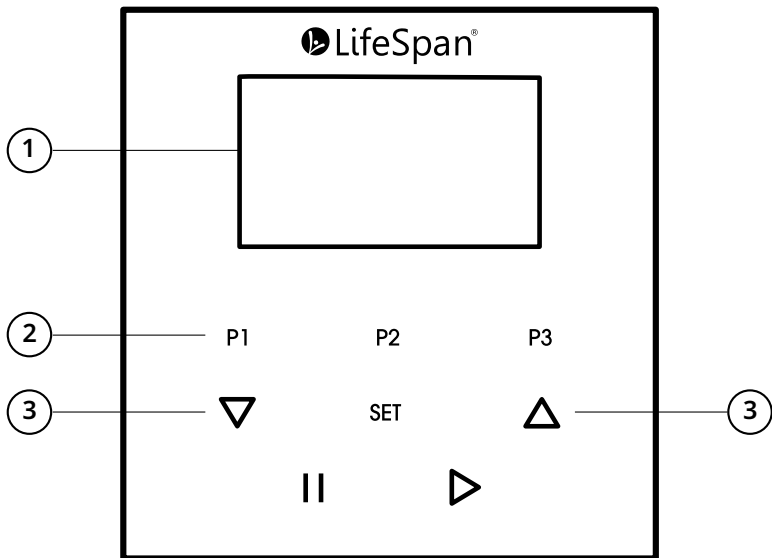

Additional Functions For a LifeSpan Desk

Console Desk Functions

1. Additional display features includes desk height
2. Preset buttons: Used for desktop height adjustment or for preset treadmill speeds
3. Up and Down Arrows: Used to adjust desktop height or making selections in Initial Setup and Personal Settings. When using treadmill will increase or decrease speed. When using the desk bike, will increase and decrease pedal resistance.

Preset Desktop Height Settings

To set the desktop height presets, your console screen needs to be in standby mode that shows the date and time. Press the Pause/Stop button to back out of any screen you may be on and it will return you to the standby screen.

- Press the up and down arrow keys to adjust the desktop to your desired height
- Press and hold the P1, P2 or P3 key. A message on the screen will tell you that the height has been successfully set.

Install the Desktop Ht. Adj. Cable

- A. Connect one end of the Desktop Ht. Adj. Cable to the back of the Console.
- B. Connect the other end of the Desktop Ht. Adj. Cable to the underside of the desktop into the Electronic Control Box.

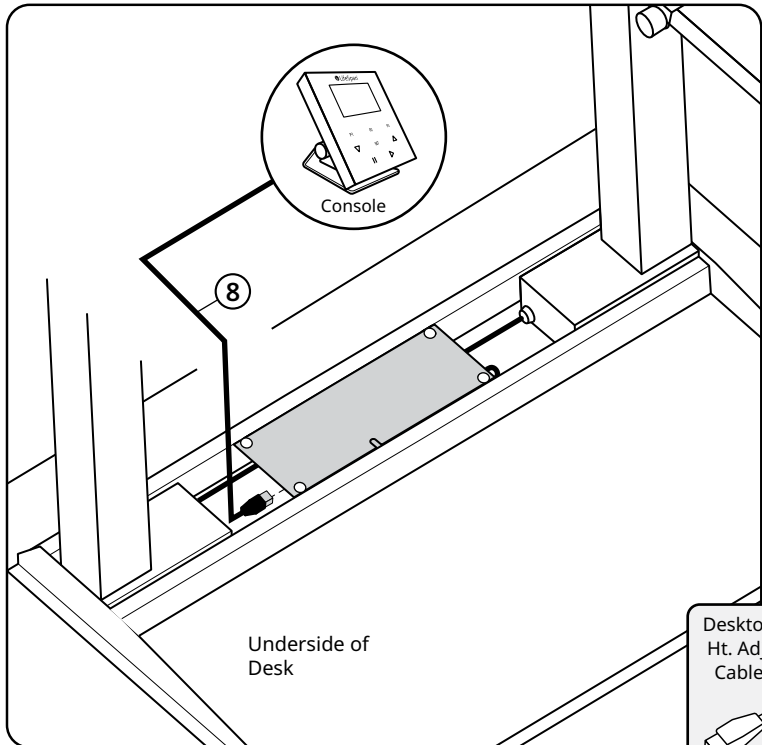

Treadmill/Bike Desk Operation

Quick Start

- Make sure the safety key is set in place.

Note:

The display will show a warning image if the Safety Key is not engaged. Please make sure that the Safety Key is fully engaged. It is possible the display will not show a warning when just partially engaged.

- Press and hold the Start Button to turn on console screen.
- Enter settings for Initial Setup Mode.
- Press the up and down arrows to adjust the desk height.
- Press and hold the Start Button for 3 seconds to start the treadmill. If using a desk bike this will start recording your exercise data).
- Use the up and down arrows to adjust speed or pedal resistance.
- Press the Pause/Stop button to stop treadmill belt, and pause the exercise program.
- Press the Pause/Stop button to exit the program and to see your exercise summary.
- Press the Pause/Stop button to exit exercise summary and enter standby mode.
- Press and hold the Pause/Stop button to turn off the Console.

Treadmill/Bike Desk Operation

Initial Setup Mode

The first time you turn on the console you will need to set the calendar, time, and some basic physical information about yourself.

Year: Use the up and down buttons to select year. Press Set.

Month: Use the up and down buttons to select month. Press Set.

Day: Use the up and down buttons to select day. Press Set.

Time: Use the up and down buttons to select time. Press Set.

Units: Use the up and down buttons to select Imperial or Metric. Press Set.

Age: Use the up and down buttons to input your age. Press Set.

Weight: Use the up and down buttons to input your weight. Press Set.

Height: Use the up and down buttons to input your height. Press Set.

You will exit initial setup mode and see the Standby Screen showing the date and time.

If you ever need to change any of the settings for Initial Setup, press and hold the Set Button.

Specifications For a LifeSpan Desk

Console Specifications

Readouts	Time, Date, Speed(Treadmill/Resistance(Bike)), Distance, Exercise Time, Calories, Steps, Speed (Bike), Summary
Display	3.5" 320x480 pixel TFT
Bluetooth	Yes
Buttons	Desk Height Preset, Height Up/Down, Speed or Resistance Preset, Increase/Decrease Speed or Resistance, Pause/Stop, Start

Specifications For a LifeSpan Desk

Desk Specifications

Speed Range	0.4 - 4.0 mph* 0.6 - 6.4 kph	
Dimensions	Two Optional Sizes:	38"W x 29"D in – (96.52"W x 73.66 D cm) 48"W x 29"D in – (120.65 W x 73.66 D cm)
Desktop Height Adjustment Range	Approx. 28 in. to 50 in. Approx. 71 cm to 128 cm	
User Height Range	3'9" - 7'2" 120 - 220 cm	
Height Adjustment Method	Electric	
Desktop Material	High-density Composite Board or Bamboo	
Desktop Surface	Durable Laminate or Bamboo	
Maximum Load on Desktop	220 lbs 100 kg	
Desk Lift Speed	Up 1.7 in/sec, Down 1.9 in/sec Up 4.3 cm/sec, Down 3.8 cm/sec	
Desk Height Memory	3 Pre-Sets	

Custom Settings

- Tap the Set Button to enter Settings mode.
- Press the up or down arrows to highlight your choice selection.
- Press the Set Button to scroll down the list to the next item.
- Press the Pause/Stop button to exit Settings mode.

Intelli-Guard — Intelli-Guard ON/OFF. (Treadmill only)

Buzzer — Turns off the normal treadmill beep that happens at every button press.

Speed Resume — Controls whether, after a Pause, the treadmill resumes the most recent walking speed, or resets to 0.4 mph. If ON, the speed resets to 0.4 mph. (Treadmill only)

Speed Limit — The maximum speed of the treadmill.

Adj. Desk — The default setting of Present lets the desk height be adjusted. The None setting keeps the desk at its current height and prevents it from being adjusted.

BT ID No. — You can change the last two digits of your console's Bluetooth Identification Number. In the event that you have two or more SC120-2022 consoles in the same room, and both have the same BT ID No, you can change one of them to be different. Your number options are from 00-99.

Sleep Mode — Set the amount of minutes before the console/treadmill go to sleep. Can set from 0 - 99 minutes.

Custom Settings

Preset — The P1, P2, and P3 preset buttons can be set for desktop height or speed. Preset desktop heights can be set to any level. Preset treadmill speeds cannot be changed. The default values for preset speeds are P1=0.4 mph, P2=1.2 mph, and P3=2.0 mph.

Settings Display

Setting	Choice 1 (Default)	Choice 2
Intelli-Guard	ON	OFF
Buzzer:	ON	OFF
Speed Resume:	ON	OFF
Speed Limit (mi/h):	4.0	2.0
Adj. Desk:	Present	None
BT ID No.	LifeSpan-TM-2100	
Sleep Mode:	10	
Preset	Height	Speed

Treadmill Desk Troubleshooting

The LifeSpan Treadmill Desk is designed and manufactured to be reliable and easy to use. However, if you have a problem, these troubleshooting steps may help you find the cause.

Problem: The console is erratic or not lighting up.

Solution: Check to make sure the treadmill desk is properly plugged in. Turn the power switch off and back on again and make sure the Safety Key is in place. Make sure the connectors located in the front of the treadmill and under the desktop are fully plugged in. If the problem persists contact LifeSpan customer service.

Problem: The treadmill motor seems strained or E1 comes up after several minutes of use.

Solution: The silicone lubricant that is applied to the deck and belt is wearing down and the belt needs to be lubricated with 100% silicone (non-aerosol). Available at www.LifeSpanFitness.com.

Problem: The treadmill automatically pauses during a workout.

Solution: The treadmill is not picking up the step count. Go into the Personal Settings section (page 29) to turn the Intelli-Guard feature off.

Problem: “UART” appears in the display.

Solution: Turn the treadmill desk power switch off. Unplug and re-plug the connections made in Step C on page 13. Make sure the thumb screws are properly tightened. Turn the treadmill desk power back on and check to see if it functions properly.

Problem: “dc-7” appears in the display.

Solution: Turn the treadmill desk power switch off. Unplug and re-plug the connections made in Step C on page 13. Make sure the thumb screws are properly tightened. Turn the treadmill desk power back on and check to see if it functions properly.

Treadmill Desk Troubleshooting

Problem: The desktop surface is not level.

Solution: Check to make sure the base feet are on a level surface. Run calibration by pressing and holding the height ▽△ adjustment buttons simultaneously for three seconds.

Problem: “E32” appears in the display.

Solution: Check to make sure the motor wires from the Left and Right Motorized Legs are properly connected into the Electronic Control Box. See page 17. Run calibration by pressing and holding the height ▽△ adjustment buttons simultaneously for three seconds.

Problem: “Table Uart Communication Time Out” appears in the display.

Solution: Check both cable connections to the console and to the desktop motor control are securely in place. Go to Settings in your console and check the setting for Adj. Desk. For your LifeSpan standing desk set to ‘Present’ instead of ‘None’. If you are using without a LifeSpan standing desk, set this to ‘None’.

Problem: The treadmill belt is beginning to slip and needs to be tensioned.

Solution: Refer to the owners manual included with the treadmill base.

Problem: The treadmill belt is beginning to drift to the left or right and needs to be aligned.

Solution: Refer to the owner’s manual included with the treadmill base.

If you experience any other error codes, please call LifeSpan Customer Support.

Bike Desk Troubleshooting

This bike desk has been designed and manufactured to be reliable and easy to use. However, if you have a problem, these troubleshooting steps may help you find the cause.



Problem: The console is erratic or not lighting up.

Solution: Check to make sure the bike is properly plugged in. Make sure the connectors on the bike and under the desktop are fully plugged in. If the problem persists contact LifeSpan customer service.

Problem: “UART” appears in the display.

Solution: Turn the bike desk power switch off. Unplug and re-plug the connections made in Step C on page 15. Make sure the thumb screws are properly tightened. Unplug the bike and plug it back in and check to see if it functions properly.

Problem: “E32” appears in the display.

Solution: Check to make sure the motor wires from the Left and Right Motorized Legs are properly connected into the Electronic Control Box. See page 17. Run calibration by pressing and holding the height   adjustment buttons simultaneously for three seconds.

Problem: “Table Uart Communication Time Out” appears in the display.

Solution: Check both cable connections to the console and to the desktop motor control are securely in place. Go to Settings in your console and check the setting for Adj. Desk. For your LifeSpan standing desk set to 'Present' instead of 'None'. If you are using without a LifeSpan standing desk, set this to 'None'.

If you experience any other error codes, please call LifeSpan Customer Support.

SC120-2022

Treadmill/Bike Desk Console

LifeSpan Fitness

785 West 1700 South Suite 1
Salt Lake City, UT. 84104

Phone: 801-973-9993

www.LifeSpanFitness.com

Version 1.0 – Sept 2021