



Owner's Manual

# **TR2000e \ TR3000e**

Electric Folding Treadmill

---

## Congratulations on Purchasing Your LifeSpan Treadmill!

At LifeSpan we take pride in the quality, safety, and reliability of our products as well as the professionalism of our sales support and customer service teams. Making it our number one priority that you have an exceptional experience using our products.

In support of this quality focus we pre-assemble parts on the manufacturing line whenever possible to reduce the number of steps and complexity of customer assembly, independently certify our products to comply with the latest industry Safety Standards, and use state of the art production processes and quality components.

Then we back LifeSpan products with excellent warranties and a responsive customer service department making it simple and easy to get assistance should the need arise.

This attention to quality, our high standard for customer service and focus on innovation has earned LifeSpan numerous awards and consistent praise from independent review groups, industry authorities and you the consumer.

Thanks for choosing LifeSpan.

Please thoroughly read this manual before you assemble or operate your treadmill. Neither LifeSpan nor its representatives can accept responsibility for any damages or injury incurred as a result of information presented in this manual except under the terms of the product warranty.

<b>About Your Treadmill</b> .....	<b>4</b>
Specifications	
Unique Features	
Warranty	
<b>Safety First</b> .....	<b>7</b>
Children and Pets	
Safety Tips	
Safety Key	
Proper Grounding	
<b>Assembling Your Treadmill</b> .....	<b>12</b>
Exploded View & Hardware	
Assembly Instructions	
<b>Console Basics</b> .....	<b>20</b>
Console Overview	
Readout Display	
Operating Keyboard	
<b>Operations</b> .....	<b>25</b>
Setting Date & Time, QuickStart	
Personal Settings	
Program Profiles	
Pre-Set Programs	
Custom User Set-Up Programs	
Heart Rate Control Programs	
<b>Maintenance and Tips</b> .....	<b>40</b>
Heart Rate Monitoring	
Hand Pulse Sensors, Chest Strap	
Cleaning, Lubrication	
Folding & Unfolding	
Moving	
Belt Tensioning	
Belt Alignment	
Troubleshooting	

## About Your Treadmill

### Specifications

#### TR2000e

Drive Motor	2.5 HP Continuous Duty
Max User Weight	300 lb (136 kg)
Heart Rate	Contact Sensors / Chest Strap Compatible
Speed Range	0.5 - 11 mph (0.8 - 18 kph)
Running Belt Size	20" x 56" (51 cm x 142 cm)

#### TR3000e

Cooling Fan	3 Speed
Drive Motor	2.75 HP Continuous Duty
Max User Weight	350 lb (136 kg)
Heart Rate	Contact Sensors / Chest Strap Compatible
Speed Range	0.5 - 12 mph (0.8 - 20 kph)
Running Belt Size	20" x 56" (51 cm x 142 cm)

#### All Models

Display Readouts	Program Profile, Time, Calories, Step Count, Distance, Heart Rate, Speed, Incline
Programs	Speed & Incline for Weight Mgmt, Healthy Living, Sports Training, 2 Custom User & 2 Heart Rate Control
Deck Suspension	8-Independent Shock Absorbers
Roller Size	2.5" (64 mm) front / 2" (51 mm) back
Incline Levels	0 - 15

### Unique Features

As a leader in the fitness industry, LifeSpan has developed a number of unique features in our treadmills making them more engaging, safer and easier to use. Learn more about how to use these features in the Personal Settings sections of this Owner's Manual.



#### **Intelli-Guard™**

Walk confidently knowing your safety is assured with Intelli-Guard™. Step away from your treadmill for more than twenty seconds and your treadmill's belt will automatically glide to a smooth stop.



#### **Intelli-Key™**

Console operation is simplified with sequential button illumination prompting you through program selection and setup.



#### **Intelli-Step™**

Never miss a stride with Intelli-Step™. Your steps are automatically calculated with meticulous precision, displaying immediate feedback.



#### **eFold™**

The TR2000e and TR3000e models offer our simple, safe, and convenient eFold feature for electric folding and unfolding at the touch of a button.



#### **USB Plus**

Dual-purpose USB port charges most of your mobile devices\* and saves your exercise results.

\* Does not charge iPad 1, iPad 2, and iPad 3.

## About Your Treadmill

### Warranty

Your LifeSpan treadmill/bike desk comes with the following limited warranty valid in North America. If you are outside of this area contact your local authorized LifeSpan dealer.

<b>Treadmill Frame</b>	10 Years
<b>Parts</b>	2 Years
<b>Labor</b>	1 Year

LifeSpan warrants that the equipment it manufactures is free from defects in materials and workmanship under normal use and services. The periods above are based on the date of purchase. During these periods, LifeSpan will repair or replace any defective part. Free labor is included on all parts that are not normally assembled or replaced by the customer within the labor period.

If within the time frames specified above, any part fails to operate properly, login to our website at [www.LifeSpanFitness.com](http://www.LifeSpanFitness.com), click on "Customer Service" and complete the form to request assistance or call 801-973-9993x4 for a Customer Service Agent (please note that certain kinds of service should only be performed by a qualified service technician).

LifeSpan reserves the right to make changes and improvements to our products without incurring any obligations to similarly alter any product purchased. In order to insure our product warranty and to ensure the safe and efficient operation of your LifeSpan product, only authorized parts can be used. The warranty is void if any parts other than those provided by LifeSpan are used.

#### Exclusions and Limitations:

- This warranty does not apply to any defects caused by negligence, misuse, improper assembly, or maintenance, accident, or "act of God."
- This warranty does not apply to discoloration of paints or plastics.
- LifeSpan shall not be responsible for incidental or consequential damages.
- This warranty is non-transferable from the original owner.

When using exercise equipment, basic precautions should always be followed, including:

- Never drop or insert any object into any opening. If an object falls into an opening, turn the power off and unplug the power cord from the outlet. Remove the object or call customer service at 801-973-9993 x4.
- Never operate this treadmill if it has been damaged or partially submerged in water.
- To reduce the risk of electric shock, unplug the treadmill from the wall outlet when not in use, before performing any maintenance, or before moving the treadmill.
- Do not use outdoors or in areas of high humidity or extreme temperature changes.
- Do not lean against or climb on the treadmill.
- Do not operate where aerosol spray products are being used or where oxygen is being administered.
- Never place the power cord under carpeting or place any object on top of the cord, this may pinch or damage the cord causing fire damage or personal injury.
- Use this exercise product for its intended use as described in this Owner's Manual. Do not use attachments that are not recommended by LifeSpan.
- Do not leave your treadmill running while not in use.

### Children and Pets

- Keep children from playing on your treadmill at all times.
- When in use children and pets should be kept at least 10 feet (3m) away.
- This treadmill can be used by children ages 12 years and above and persons with reduced physical, sensory or lack of experience and knowledge if they have been given supervision or instruction concerning use of the appliance in a safe way and understand the hazards involved.
- Cleaning and user maintenance shall not be made by children without supervision.

## Safety First

### Safety Tips While in Use

- Always consult a physician before beginning an exercise program.
- If you experience chest pains, nausea, dizziness or shortness of breath, stop exercising immediately and consult your physician before continuing. Do not wear clothing or jewelry that might catch on any part of the treadmill.
- Wear shoes with high traction rubber soles. Do not wear shoes with heels, leather soles, cleats or spikes.
- In case of emergency, grab onto the side handrails and place your feet on the side rails located on each side of the running belt.
- Do not walk or run backwards on the treadmill, always face forward.
- Allow the running belt to fully stop prior to getting off the treadmill.
- Keep the treadmill on a solid surface, with the side rails and front of the treadmill a minimum of 2 feet (0.6m) from any walls or furniture. Make sure that the area behind the treadmill remains completely clear during use. A minimum of 7 feet (2m) of clearance is required for safety reasons.

### Safety Clearance

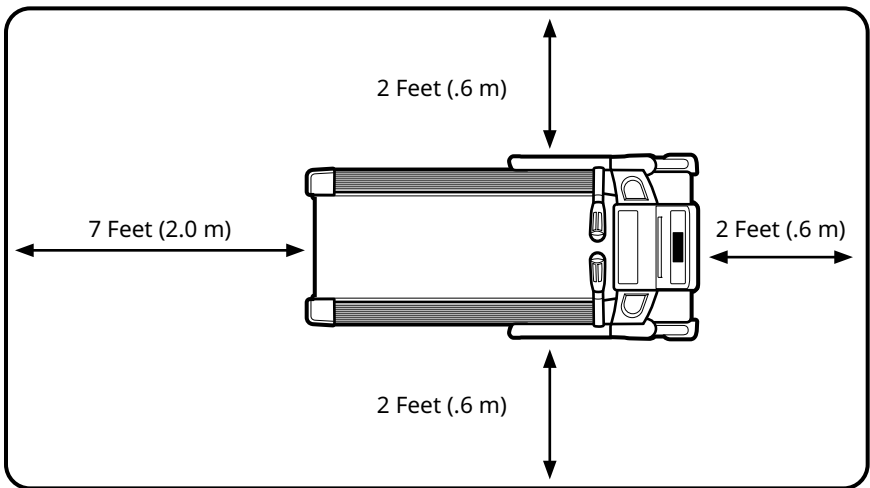



### Safety Key

The safety key is required to operate this treadmill. With the safety key installed the treadmill is operational. With the safety key pulled, power is turned off to the motor making the treadmill inoperable.

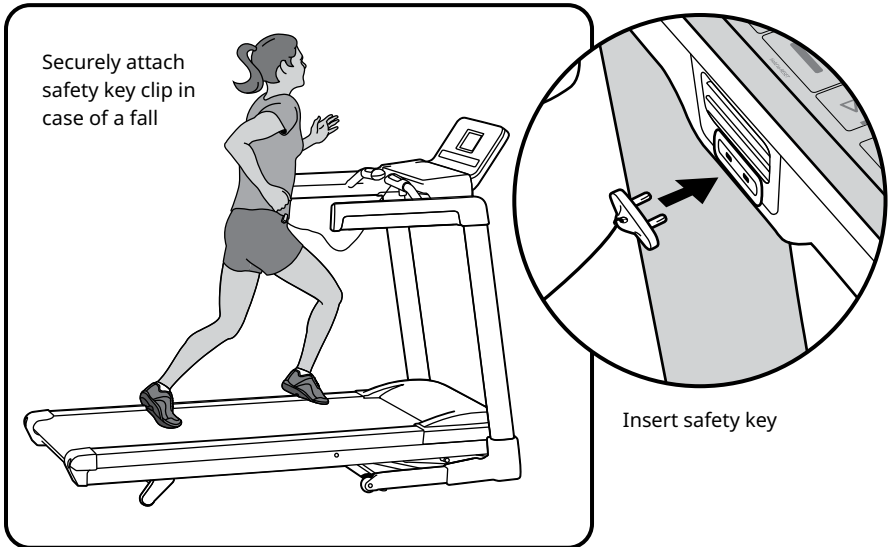

**CAUTION:** For your safety always attach safety key clip to an article of clothing prior to use. The safety key clip needs to be securely attached to clothing parallel to or above the height of the safety key.

**WARNING:** Heart rate monitoring systems may be inaccurate. Over exercising may result in serious injury or death. If you feel faint stop exercising immediately.

**Note:** Read all instructions and save for future reference.

# Safety First

## Proper Grounding

LifeSpan equipment must be grounded. Improper connection of the equipment's grounding conductor can result in the risk of electric shock. Check with a qualified electrician or service person if you are in doubt as to whether the outlet is properly grounded. Do not modify the plug provided with the product or use a ground plug adapter to adapt to a non-grounded outlet. If the plug will not fit in the outlet, have the proper outlet installed by a qualified electrician.

## Power Cord Options

This treadmill should only be used with the proper power cord and power outlet. Several power cord options (shown below) are available from LifeSpan. We do our best to include the correct power cord with the treadmill for your area. In the event that the correct power cord is not included in the packaging please contact your local distributor.

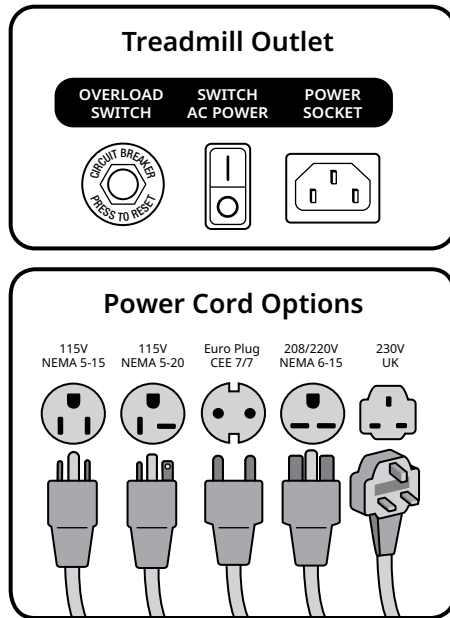

Do not use extension cords between the treadmill and power outlet.



Do not plug into a GFI outlet or circuit as it may trip the breaker.

# Assembling Your Treadmill

## Exploded View

Prior to starting the assembly process take all of the parts out of the box. Remove plastic bags and lay them out on the floor to become familiar with the components.

Since your treadmill is a heavy piece of equipment it is recommended you use two people during assembly and follow these assembly instructions to reduce any problems that could occur.

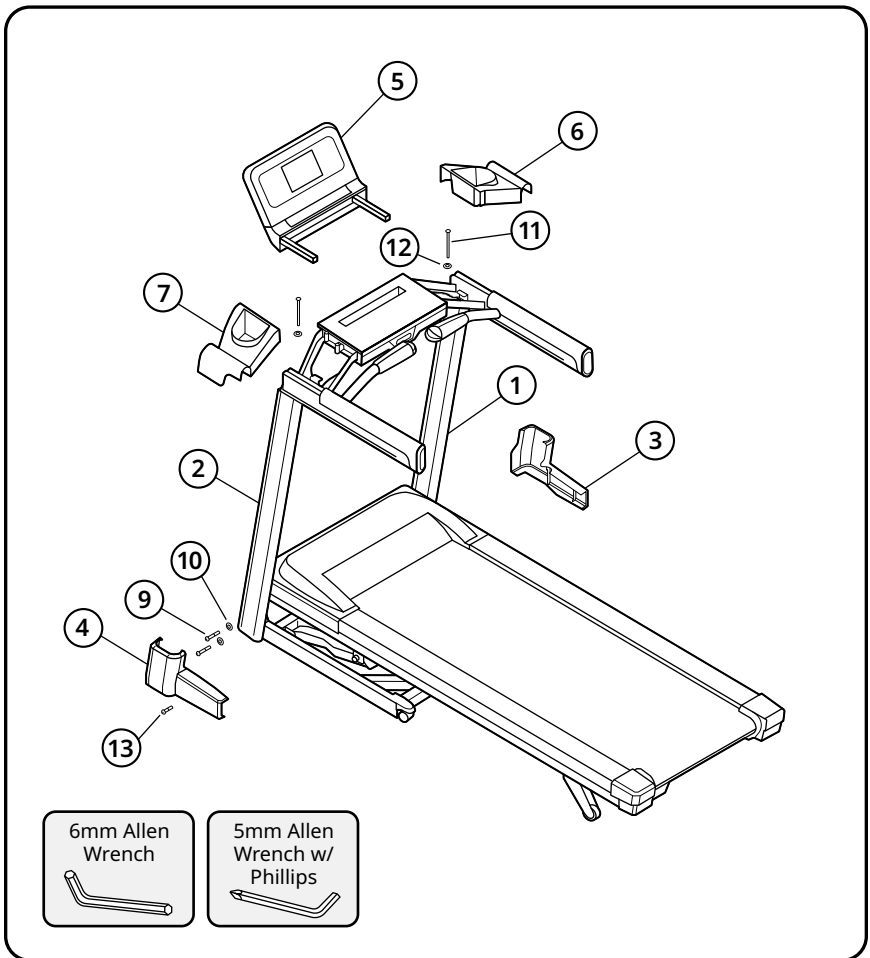

# Assembling Your Treadmill

## Hardware Included

Item#	Part Description
1	Right Upright Post
2	Left Upright Post
3	Right Upright Post Cover
4	Left Upright Post Cover
5	Console
6	Right Cup Holder
7	Left Cup Holder

## Hardware Bag Contents

Item #	Qty.	Hardware Description
N/A	1	6mm Allen Wrench
N/A	1	5mm Allen Wrench with Phillips Screw Driver
9	4	M10 x 45L Bolt - (Upright Attachment)
10	4	M10 Washer - (Upright Attachment)
11	2	M8 x 100L Bolt - (Handlebar Hold Down)
12	2	M8 Washer - (Handlebar Hold Down)

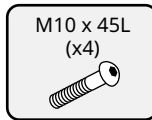
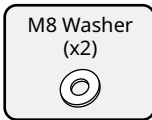
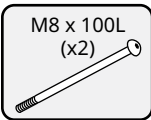

## Pre-installed Hardware (not shown)

Item #	Qty.	Hardware Description
13	2	M4 x 8L - (Upright Cover Attachment)
14	4	M8 x 15L Bolt - (Console Attachment)
15	4	M4 x 8L Screw - (Cup Holder Attachment)

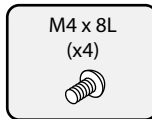
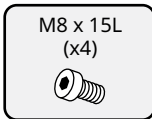
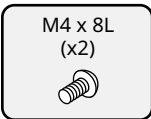

# Assembling Your Treadmill

## Step 1: Unpacking Treadmill

- A. Cut packaging straps and remove.
- B. Remove the box top.
- C. Remove small parts and packaging material and unwrap parts.
- D. Cut the corners of the bottom box and remove all packaging material to begin assembly. The treadmill can be assembled in the box. No need to pick the treadmill up to remove it from box.
- E. Cut plastic shipping strap holding deck frame to base.

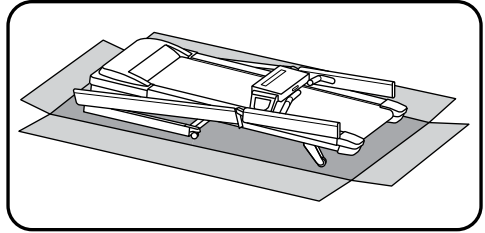

## Step 2: Upright Post Attachment

- A. Carefully fold the uprights with handlebars up into the upright position.
- B. Carefully lay handlebars down as the uprights are brought up into position. This will protect against any accidental damage to wires coming up through the upright into the handlebars.
- C. Align the holes in the lower portion of the upright with the threaded holes in the frame.
- D. Install the four M10 x 45L bolts (9) and M10 washers (10), two in each upright. The best way to handle this is to loosely install all four bolts and washers and then tighten once all bolts are installed.

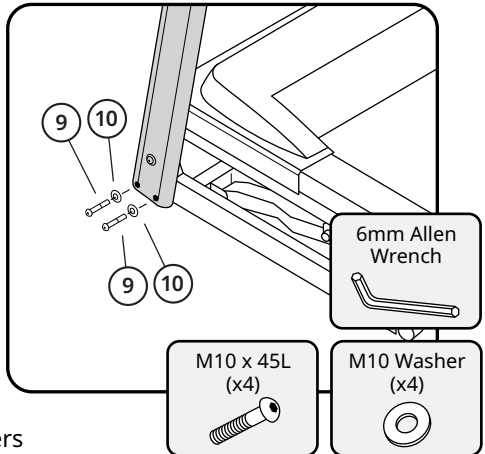
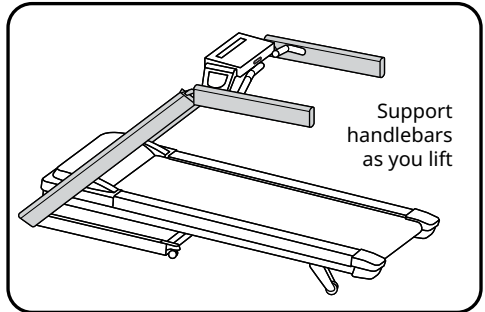

## Assembling Your Treadmill

### Step 3: Upright Post Cover Attachment

- A. Remove pre-installed M4x8L Screw (13).
- B. Install the Left Upright Cover (4) by sliding the front of the cover around the upright and centering or aligning the cover on the upright.
- C. Install the M4 x 8L Screw (13).
- D. Repeat steps A and B for the Right Upright Cover.

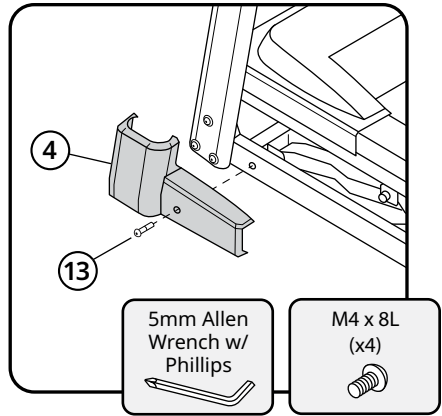

### Step 4: Handlebar Attachment

- A. Place the M8 x 100L Bolt (11) and M8 washer (12) through the left handlebar and into the uprights being careful not to damage any wires running through the handlebar. Repeat for the right handlebar.
- B. Loosely thread both bolts into the upright prior to tightening.
- C. Fully tighten both handlebar attachment bolts.

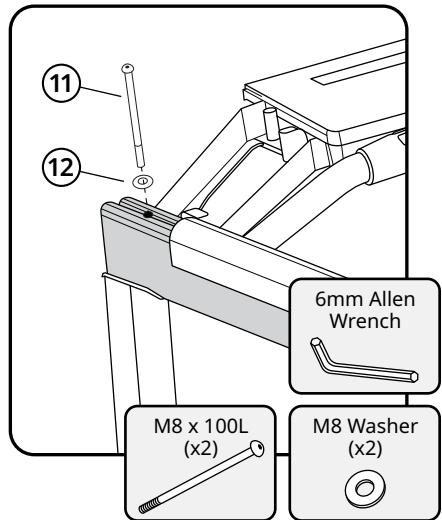

# Assembling Your Treadmill

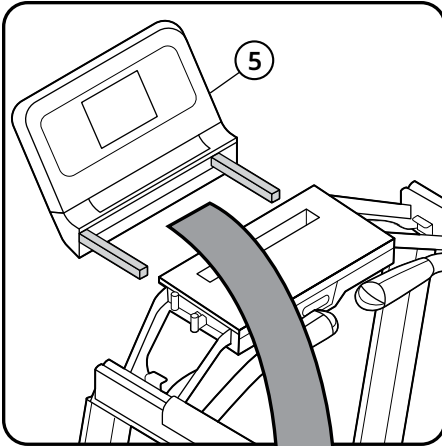

## Step 5: Console Harness Attachment

- A. Slide the square mounting tubes (protruding from the front of the Console (5)) partially into the console mount as shown in the figure to the left. Do not slide the console all the way in as wire connections need to be made.
- B. Securely attach the two ribbon cables (flat cables).

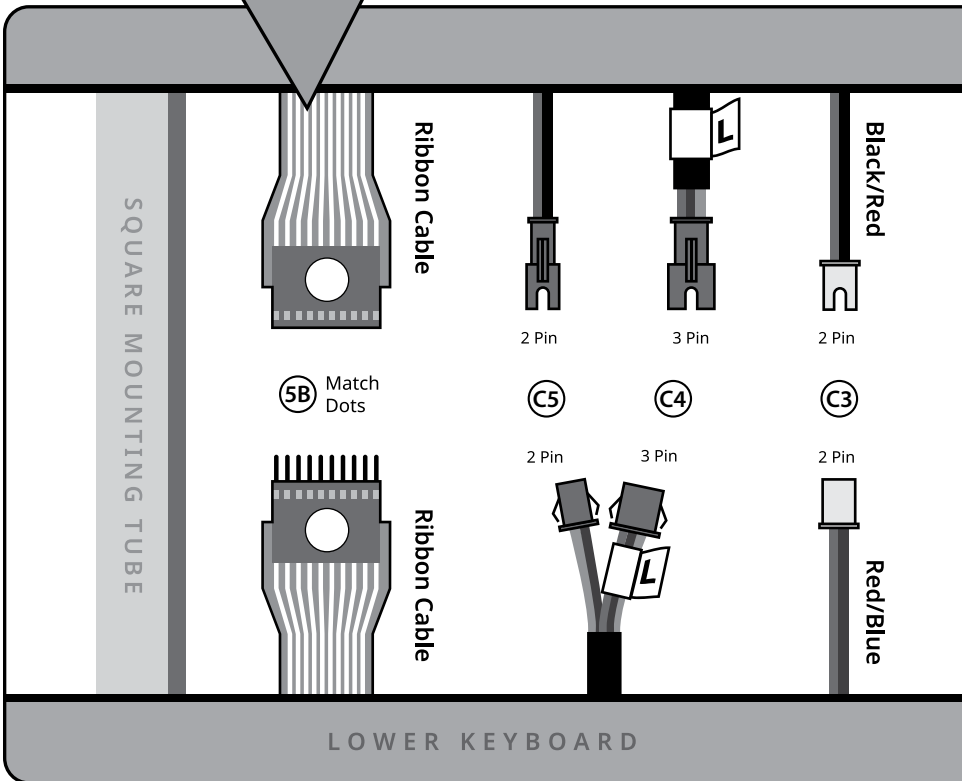

## Assembling Your Treadmill

- C. Securely attach the seven remaining cable connectors – There are four 2-pin, two 3-pin and one 10-pin connector that will need to be connected.
1. Attach the 10-pin connectors (7-pin connectors) together (C1).
  2. Attach the wires labeled “SK” together (C2).
  3. Attach the White 2-pin connector wires together (C3).
  4. Next, attach the two 3-pin connectors (C4) together. There are labels on these that say L and R. Connect the L to L and the R to R. These are for the handlebar speed and incline switches.
  5. The remaining two 2-pin connectors are for the contact heart rate sensors and it doesn't matter which gets plugged into the other.
- D. Carefully tuck all wires into the bottom or top console housing.

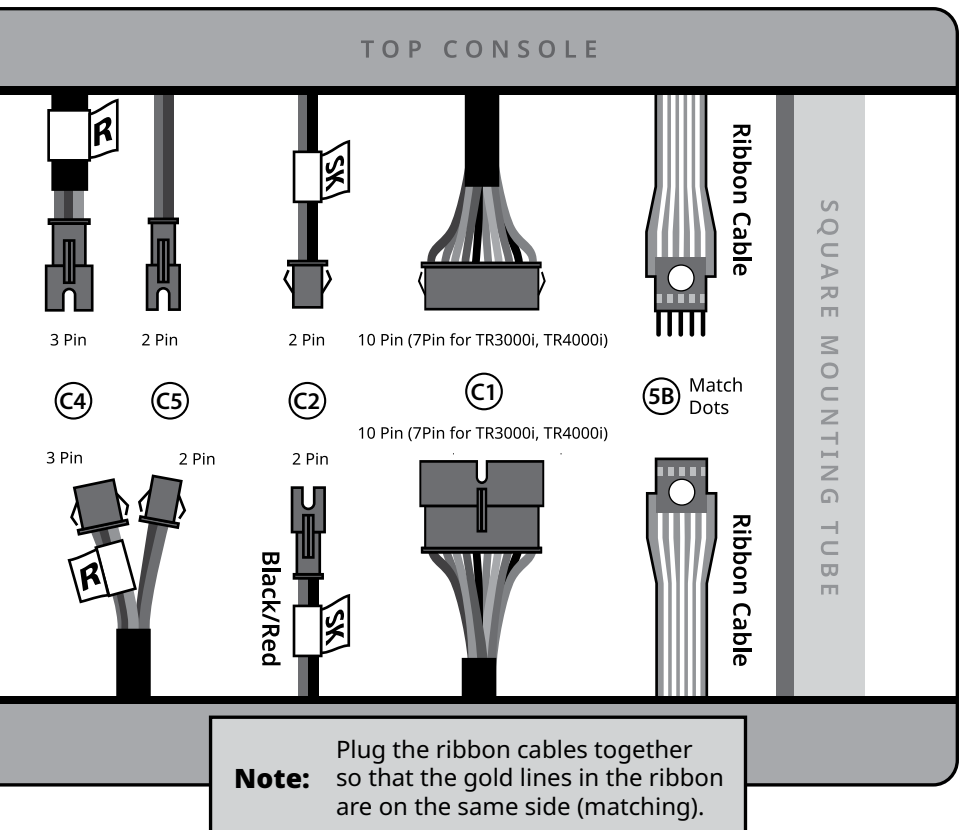



# Assembling Your Treadmill

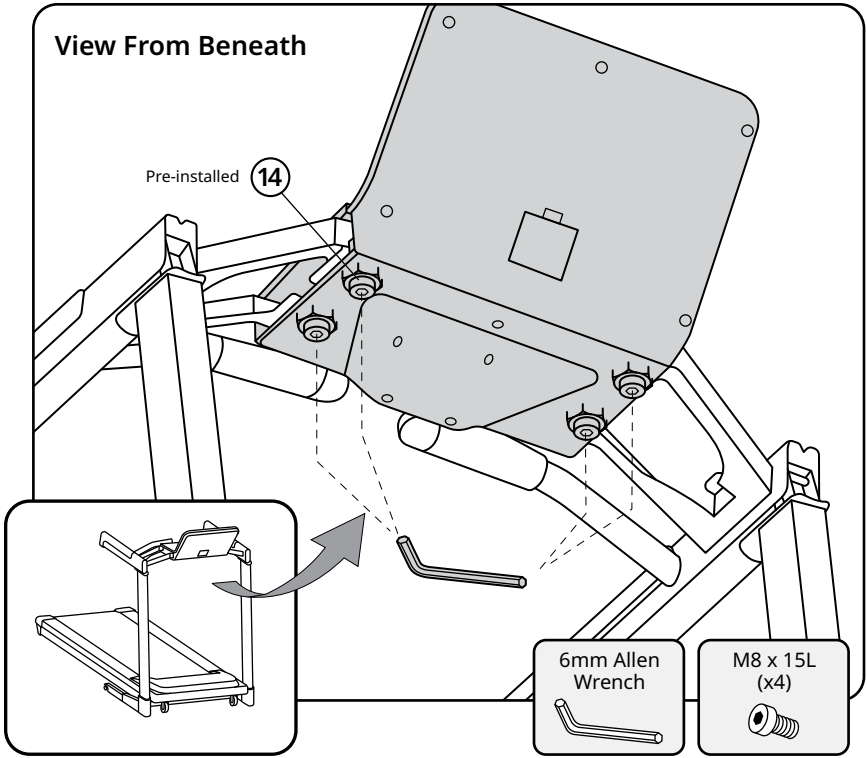

## Step 6: Securing Console

- A. Slide the console fully into the mounting brackets. If the console does not want to slide in completely, loosen the four pre-installed M8 x 15L Bolts (14) with the provided 6mm Allen wrench to eliminate any friction.
- B. Once the console is fully installed, tighten the four M8 x 15L Bolts.

## Step 7: Cup Holder Attachment

- A. Remove the two pre-installed M4 x 8L Screws (15) with the provided Phillip's head screwdriver from the bottom of the Right Cup Holder.

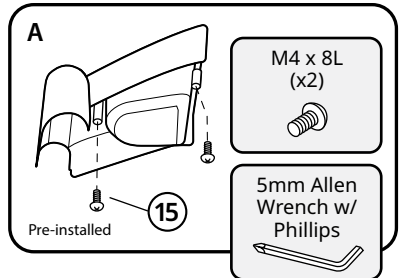

## Assembling Your Treadmill

- B. Place the Right Cup Holder (6) over the handlebar and into the frame as shown.

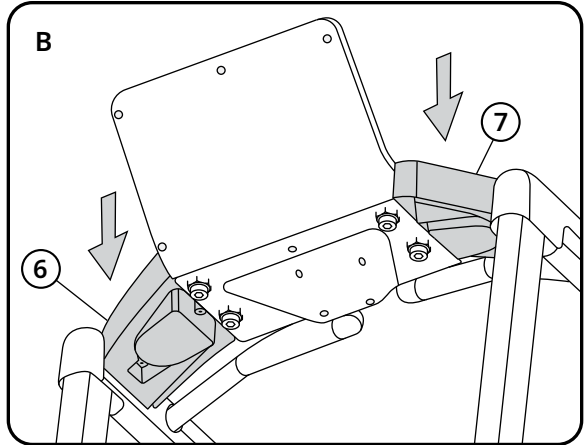

- C. Loosely install the two screws removed in step A. Once both screws are installed, securely tighten both screws.
- D. Repeat steps A through C for installing the Left Cup Holder (7)

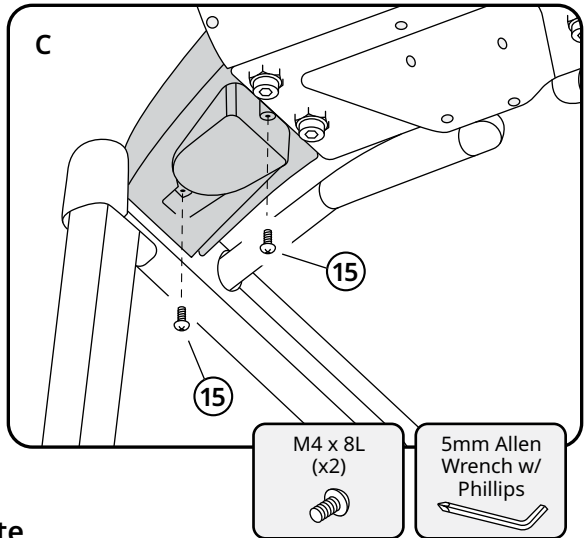

### Step 8: Time and Date

It's important that the date and time be set on the console so that your exercise data can be time stamped. Please go to the Time Setting section on (page 25) prior to using your treadmill.

## Console Basics

### Console Overview

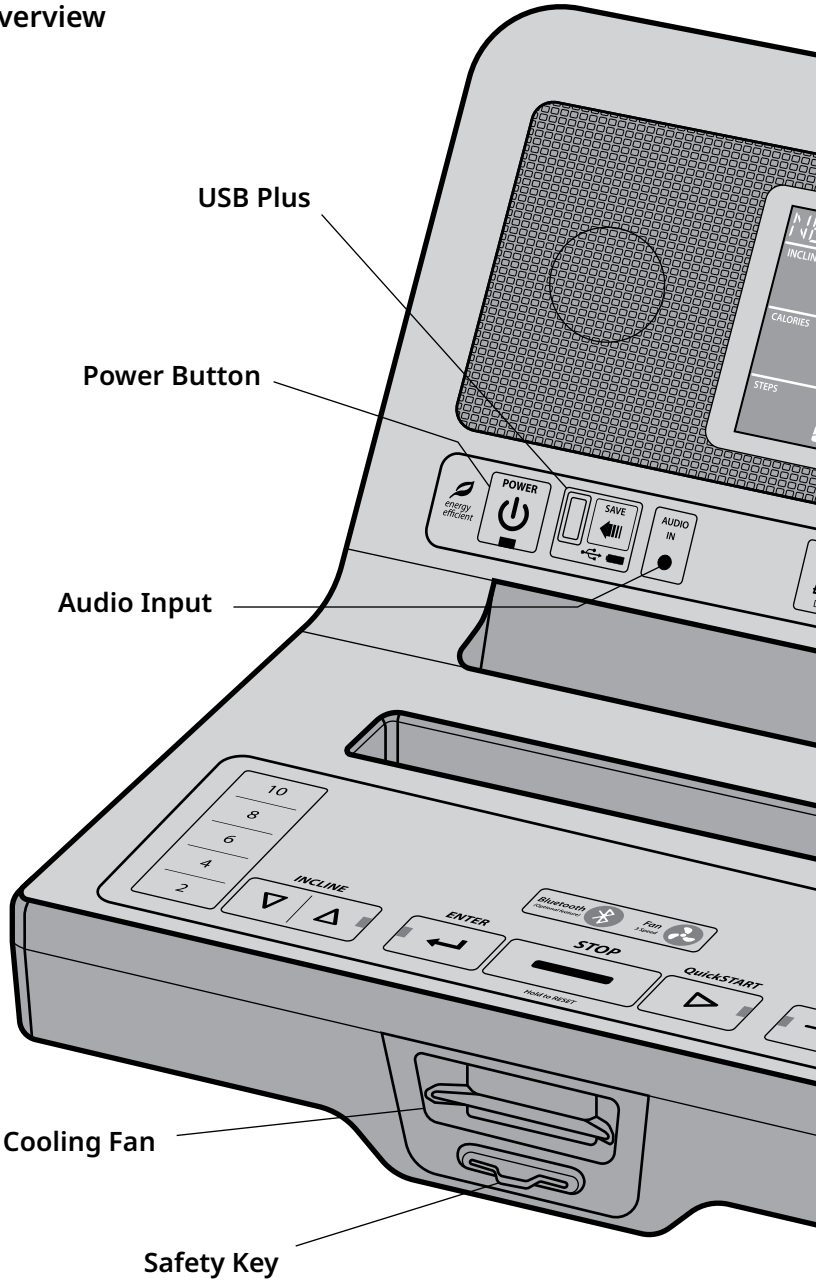

## Console Basics

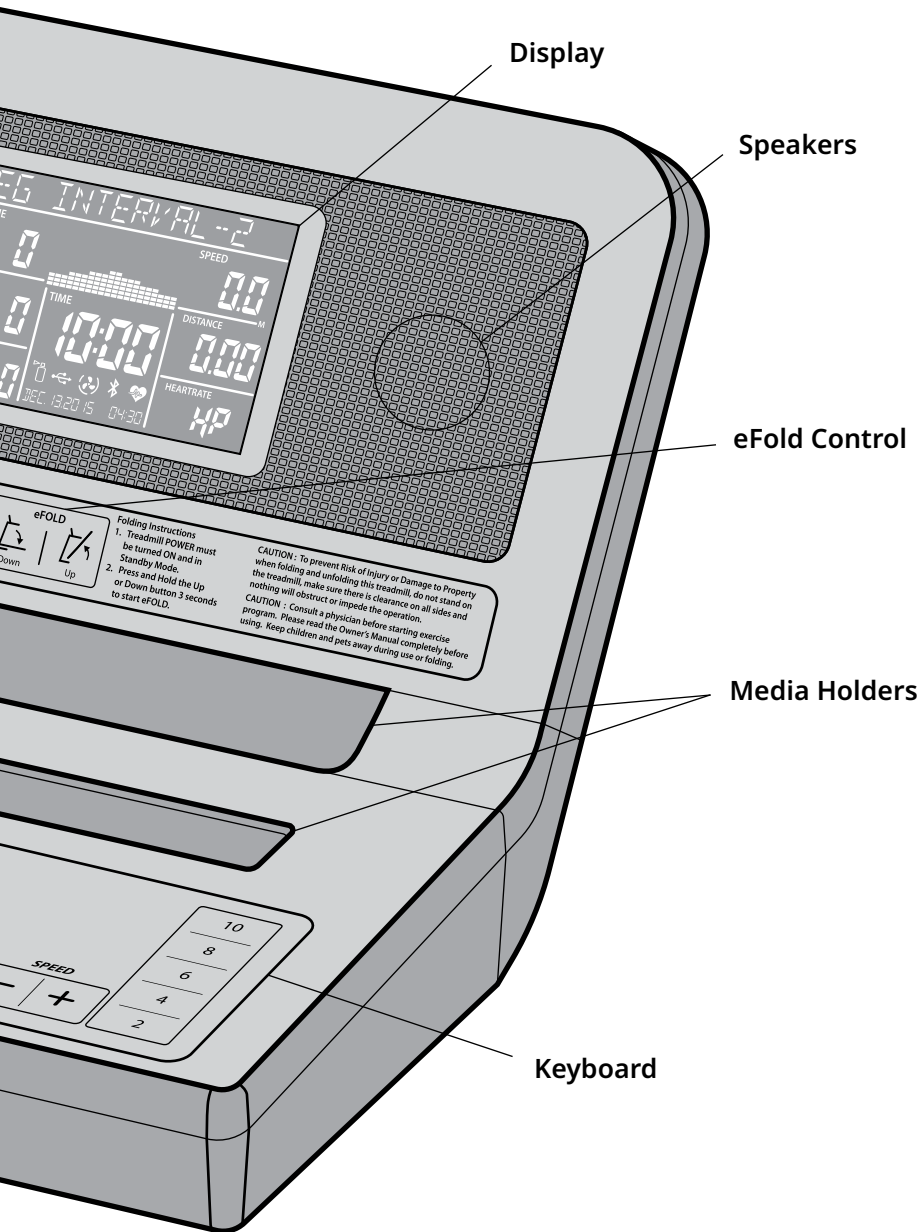

## Console Basics

### Readout Display

A blue backlit LCD display provides all the information you need to monitor your exercise results and get the most out of your exercise program.

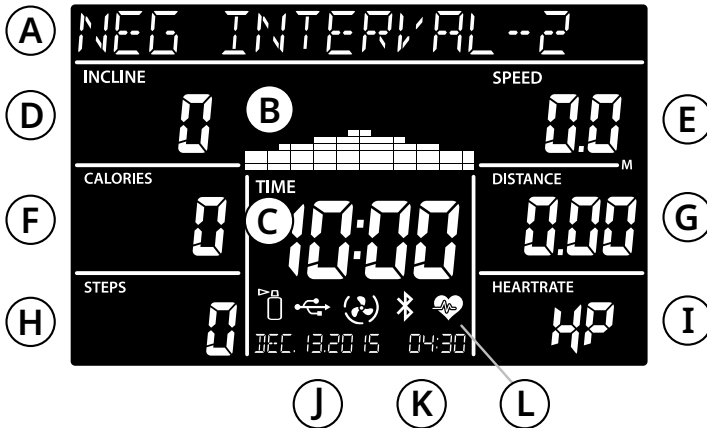

- A. **Message Window** - This 16-character window helps step you through program setup, then displays the program selected while you exercise.
- B. **Program Matrix** - Divides the workout programs into 20 segments with varying intensity levels. These programs can be viewed in levels of incline or speed.
- C. **Time** - The workout time elapsed or the workout time remaining.
- D. **Incline** - The level of belt incline ranging from 0 to 15.
- E. **Speed** - The speed you are traveling in miles per hour (this reading can be changed to kilometers by using the Personal Settings Mode).
- F. **Calories** - Estimated calories burned is calculated by using a widely-accepted equation, using body weight and distance covered.
- G. **Distance** - Total distance traveled in miles or kilometers since the beginning of the workout.
- H. **Step Count** - Works like a pedometer, counting your steps while you walk.
- I. **Heart Rate** - Your measured heart rate using the hand pulse sensors located on the front handlebars or chest strap.

- J. **Date** - The date is presented as the month/day/year below the program matrix.
- K. **Time** - The time of day is shown below the program matrix using a 24-hour reading.
- L. **Indicator icons:**



**Lube** - This icon illuminates after 100 hours of use showing it's time to lubricate the treadmill belt (please refer to the Maintenance and Tips section for lubricating instructions).



**USB** - This will light up when your exercise data is being transferred to a USB flash drive.



**Cooling Fan** - Indicates the fan is on - low, medium or high.



**HRC** - This icon flashes when your pulse is being taken.



**CAUTION:** The Intelli-Guard feature will automatically be disengaged when the treadmill is operated at speeds under 1.0 mph (1.6 kph). If the speed is within this parameter "Step" will flash. When the "Step" is flashing, the treadmill will not automatically pause. If the speed is above 1.0 mph (1.6 kph) Intelli-Guard™ will not activate until 25 steps are taken and counted.



**CAUTION:** At 20 seconds the console will beep once per second for 5 seconds and then automatically pause the treadmill. These beeps are a notice that the treadmill belt is about to stop. If for some reason you are still on the treadmill when this occurs move your feet to the side rails and prepare for the belt to stop. The Intelli-Guard feature does not replace the use of your Safety Key or using proper precaution in stopping the treadmill when it is not in use.

## Console Basics

### Main Keyboard

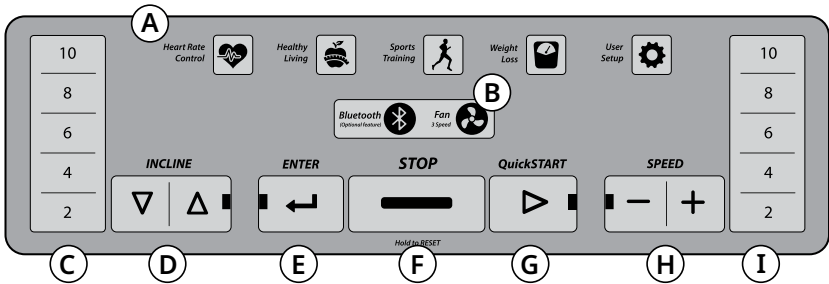

- A. **Program Group** (TR3000e) - Choose from Heart Rate Control, Healthy Living, Sport Training, Weight Loss, and User Setup.
- B. **Cooling Fan** (TR3000e) - Operates the 3-speed fan in the front of the console.
- C. **Quickset™ Incline** - Select an incline level of 2, 4, 6, 8 or 10.
- D. **Incline** - Raise and lower the running belt incline.
- E. **Enter** - Confirm a selection.
- F. **Stop/Reset** - The Stop button will pause your workout. Holding it for 3 seconds will also clear the workout and reset saved exercise data.
- G. **Start/QuickSTART** - Begin a Manual Program with one touch.
- H. **Speed** - Increase or decrease belt speed.
- I. **Quickset™ Speed** - Select a speed of 2, 4, 6, 8, 10 mph (2, 4, 6, 8, 10 kph).

### Top Keyboard

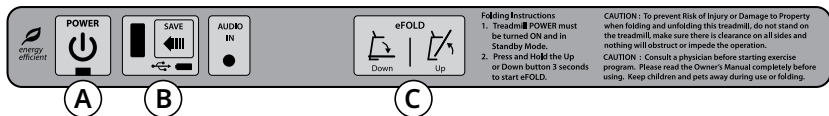

- A. **Power** - This button can be used to turn the console “on” from Energy Saving mode and to turn the console “off” when in Standby mode.
- B. **Exercise Data Save** - This saves your workout results to a USB flash drive.
- C. **eFold** - Folds and unfolds the treadmill with the press of a button.

#### Note:

Make sure the main on/off switch, located at the front of the treadmill base (near the floor) is on.

## Setting the Date and Time

Before getting started using your treadmill make sure the date and time are properly set on the console to ensure that your exercise data is properly recorded.

To set the date and time in your console follow these steps:

- A. Pull and re-install the safety key.
- B. Press the Quick Speed 10 button. Clock illuminates in the display.
- C. Press the Quick Speed 10 button again. Update Calendar illuminates in the display after 3 seconds. Press Enter.
- D. Press the +/- buttons to set the correct Year. Press Enter.
- E. Press the +/- buttons to select the correct Month. Press Enter.
- F. Press the +/- buttons to select the correct Day. Press Enter.
- G. Press the +/- buttons to set the Hour. Press Enter.
- H. Press the +/- buttons to set the Minute. Press Enter.

## QuickSTART

The quickest way to get started with a workout is to press the QuickSTART button. This will start the treadmill in manual mode with the time counting up from 00:00. You can also set a desired workout Time and update your Weight in the console for more accurate calorie calculation by following these steps:

- A. Press Enter to select manual mode.
- B. Select the amount of time (in minutes) you want to use the manual program by pressing the speed +/- buttons. Press Enter.
- C. Use the speed +/- buttons to set your weight. Your weight is used to more accurately calculate calories burned. Press Enter.
- D. Press Start and the treadmill will start with the time counting down from the preset time.
- E. To increase speed press the + button. The speed will increase up to 11.0 mph (18 kph) on the TR2000e and 12.0 mph (20 kph) on the TR3000e.



## Operations

### Personal Settings

The TR2000e and TR3000e comes with the ability for you to personalize several console settings including:

**Intelli-Guard™** - This feature is triggered when the treadmill senses you are no longer walking or running. For safety purposes it automatically pauses the belt to avoid accidental falls resulting in possible injury. There are several factors that affect the accuracy of this feature including your walking style, weight and usage characteristics. While we don't recommend it, this feature can be turned off if required.

**English or Metric** - Used for both Speed and Distance in miles or kilometers shown on the display.

**Calendar** - Date and Time are shown on the display readouts, but can be turned off with this setting. We recommend you keep date and time turned on to accurately track your results.

**Energy Savings** - Turn the Energy Saving feature on or off.

**Pause Time** - The number of seconds the treadmill will pause before going into sleep mode. This feature can also be turned off entirely.

**Audible Beep** - Turns off the audible alert that beeps for speed and incline changes or when the treadmill is starting or stopping.



**WARNING:** The audible alert is turned on from the manufacturer to warn the user that the treadmill is starting or the speed is changing. Turning this alert off is done at the sole discretion of the user.

**Resume Speed** - This lets you start the treadmill at the speed it was going when paused.

## Personal Settings

Follow the steps below to make changes to the Personal Settings options.

Configuration Steps	Information Displayed
Press and hold STOP and then SPEED + for 3 seconds to enter Personal Settings Mode. The first screen shows the software version for your console. Press ENTER to continue	Engineering Mode 4.0      49 16 12.8.2016
Press SPEED +/- to turn <b>Intelli-Guard™</b> on and off. Press ENTER to continue	Intelli-Guard      On or Off
<b>Roller Size</b> is displayed. (Do not modify) Press ENTER to continue	Roller 600
Press SPEED + / - to change from <b>English (EN)</b> to <b>Metric (SI)</b> . Press ENTER to continue.	Select the units  EN or SI
Press Speed +/- to turn <b>Calendar</b> on or off. (Do not modify) Press ENTER to continue	Set Calendar      On or Off
Press SPEED +/- or to turn <b>Energy Saving</b> mode on or off. Press ENTER to continue	Electricity      On or Off
This screen shows the <b>Total Distance</b> exercised in miles or kilometers. Press ENTER to continue	Total Distance 0                  000
This screen shows <b>Total Hours</b> of use. Press ENTER to continue	Total Hours 0                  000
Press SPEED +/- to set the amount of <b>Pause Time</b> required before the treadmill resets. The options in seconds are 90,180, 300 or Off. Press ENTER to continue	Select the pause time  90, 180, 300 or Off
Press Speed +/- to turn <b>Audible Beep</b> on or off. Press ENTER to continue	Beep              On or Off
Press SPEED +/- <b>Resume Speed</b> allows the treadmill to start at the speed it was running when paused. (If set to 0, the treadmill will start at .5 mph. If set to 1, the treadmill will start at the pre-paused speed.) Press ENTER to return to normal console operations	Resume Speed    0 or 1

## **Operations**

### **Program Profiles**

There are numerous programs available to help you add structure and variety to your exercise program.

#### **Preset Programs**

Remember, if you simply get on your treadmill and go at the same pace, for the same amount of time everyday your body will only improve to the level of the workouts you are pushing yourself to do. To help get the most out of your time spent exercising, LifeSpan treadmills include a full range of workout programs. All programs are available in either "Speed" or "Incline" mode with 3 levels of intensity that you select during program set-up. When the "Speed" mode is selected, the belt speed will vary during your workout while the incline level stays constant. In "Incline" mode the speed remains constant while the incline is adjusted by the program. In either mode you have full control of the setting that is not being controlled by the program.

To complement these preset programs you also can design your own Custom User Program or use either of the two types of Heart Rate Control training programs.

#### **Custom User Programs**

There are two user programs that provide you with the ability to build custom program profiles for your specific workout requirements. In Custom User Programs you set the workout time and then for each of the 20 program segments you set the speed and incline. This program is different than our preset programs in that both speed and incline can be controlled simultaneously. As such, the program matrix display readout will show both incline and speed at the same time with the incline on the left portion of the matrix and the speed on the right portion of the matrix.

### Heart Rate Control Programs

#### Constant Heart Rate

The Constant Heart Rate program is a steady state program that lets you select a single heart rate to maintain throughout your workout. The treadmill will adjust the belt speed or incline every 10 seconds during the workout to maintain your heart rate close to the target you've selected.

#### Interval Heart Rate

The Interval Heart Rate program is designed to help you increase anaerobic endurance and improve heart rate recovery. The program lets you select both a High target heart rate and a Low recovery heart rate.

After a 3-minute warm-up, the console will adjust the incline or speed (your choice) every 10 seconds until you reach your High target heart rate. It will keep you there for 2 minutes. Then it will adjust incline or speed every 10 seconds to reduce your heart rate to your Low recovery level, then keep you there for 2 minutes. This repeats until the end of your workout.

It is recommended that you set the workout time to 30 minutes or longer to use this program effectively.

**Note:**

Remember that the console needs to receive your heart rate through the grip pulse or a heart rate chest strap during the course of the workout.

## Operations

### Preset Program Operation

To use one of the Preset Programs follow the steps below:

- A. **Select Program** – Press the + / - buttons on the keyboard to cycle through the program list, or use the Program Buttons to find your desired program then press Enter to complete the selection.
- B. **Select Speed or Incline Mode** – You can choose to run each program in either Speed or Incline mode. Press the +/- buttons on the keyboard to make your selection and then press Enter.
- C. **Set Program Level** – There are 3 levels of intensity with each preset program (1 being the easiest and 3 being the most difficult). Press the Speed +/- buttons to select the desired level then press Enter.
- D. **Set Time** – Set the program Time of your workout by pressing the Speed +/- buttons then press Enter.
- E. **Set Weight** – Set your Weight in the console for more accurate calorie calculation by pressing the Speed +/- buttons then press Enter.
- F. **Press the Start Button** – to begin your workout.

### Preset Programs

#### Long Slow Distance

(40 minutes default)

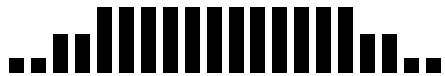

Long Slow Distance is a great workout for anyone! Beginners can ease into their exercise program and should include a Long Slow Distance workout each week to maximize overall cardiovascular endurance development. Long Slow Distance workouts are also great for experienced exercisers on days following a harder, higher intensity workout.

#### Short Interval

(20 minute default)

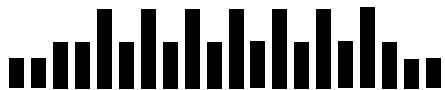

Short Intervals are ideal for beginning exercisers that want to start gaining the benefits of interval workouts but aren't quite ready for a longer-intensity interval workout. Short intervals are also ideal for experienced exercisers to develop their speed and anaerobic fitness. Remember, it's important to vary exercise intensity and duration to maximize overall fitness development so be sure to include some interval workouts at least once a week.

## Moderate Interval

(30 minute default)

As you begin to exercise on a regular basis and feel your fitness improving you will be ready to begin doing “Moderate Intensity Interval” workouts. Remember in this workout you alternate between an easy recovery interval and a higher intensity interval. You should feel comfortable to push yourself as you are never too far away from an easier recovery interval. This workout will improve your overall aerobic endurance while also maximizing anaerobic fitness development.



## Long Interval

(40 minute default)

Long Interval workouts are great to maximize calorie burn and improve anaerobic fitness. As in the Moderate Interval workouts, remember you have a recovery period after each higher intensity interval so you can comfortably push yourself to exercise at a progressively higher level.



## Negative Interval 1

(30 minute default)

The Negative Interval-1 workout provides the benefits of a Steady Pace workout but pushes you to slowly obtain a progressively higher steady state exercise intensity and then allows you to slowly decrease the exercise intensity. As your fitness level improves, you can slowly push yourself to a higher peak in overall exercise intensity.



## Negative Interval 2

(30 minute default)

The Negative Interval-2 workout has been designed to provide your body with a workout that begins with a slight increase in exercise intensity and ends with a progressive decrease in intensity. A workout with an increase and decrease in intensity will most ideally develop your overall aerobic cardiovascular endurance. A workout that decreases in intensity is also ideal for maximizing calorie burn, but most ideally when done for a longer duration, such as 40 or 50 minutes.



## Operations

### Fartlek

(30 minute default)

Varying your exercise intensity with a constantly changing interval



workout that starts out at an easy pace and then increases to a moderate or higher intensity pace will add variety into your workouts, make workouts go by faster and provide great fitness benefits. Constantly varying intensities in a workout have been found in brain research to have great benefits on improving overall brain fitness.

### Uphill Climb

(30 minute default)

Gradually increase the intensity of your exercise with this fun



Uphill Climb workout. The goal of the Uphill Climb is to stimulate your body to improve overall cardiovascular fitness while maximizing muscle cell development in working muscles. You will maximize calorie burn during the peak levels while allowing your body to exercise longer and still benefit from the higher intensity as you slow down and return to your starting level.

### Pyramid Climb

(30 minute default)

Gradual increases in intensity is ideal to stimulate your body to



improve overall cardiovascular fitness, while also maximizing muscle cell development in working muscles. You will maximize overall calorie burn during the peak intensity levels while allowing your body to exercise for a longer duration and still benefit from the higher intensity as you gradually slowdown.

### Plateau Climb

(40 minute default)

A Plateau Climb workout will provide you with all the benefits of

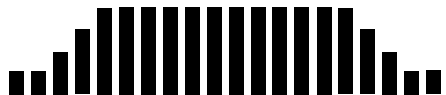

other steady state workouts, but push you to maintain a higher steady state exercise level. As you improve your overall health and fitness you can slowly push to a higher overall intensity for longer periods of time.

## Ladder

(30 minute default)

One of the greatest benefits of exercise are the direct benefits



exercise has on the heart and cardiovascular system. The Heart Health Ladder has been specifically designed to provide your heart and cardiovascular system with a series of progressively harder exercise intensity's that will improve your overall aerobic endurance, while also stimulating anaerobic endurance. Remember that it may be challenging for a few minutes, but each progression has been carefully designed to provide recovery intervals so you can push to improve your cardiovascular fitness.

## Uphill Interval

(20 minute default)

Uphill Interval workouts are unique



in that they provide your body with the benefits of an interval workout, with the added benefits of gradually increasing the overall intensity. In this workout you should begin at a level that is comfortable and then increase the intensity during each maximum interval, pushing to a slightly higher intensity each time. You will get maximum overall calorie burn during of the higher intensity intervals, while at the same time working on improving your overall anaerobic fitness.

## Steady Pace

(40 minute default)

Improve your fitness while also



simulating your body to burn more fat with this workout. Steady Pace workouts are great for helping you establish an improved overall endurance base. Most "Steady Pace" workouts focus on maintaining one set workload throughout the entire workout. Your goal is to be sure you are exercising within a low moderate intensity to a high moderate intensity during the workout.



## Operations

### Long Slow Distance 2

(40 minute default)



Compared to the Long Slow

Distance 1 program, this workout expedites the rate of increasing exertion, allowing for more workout time to be spent at higher levels of intensity.

### Cardio Run

(20 minute default)

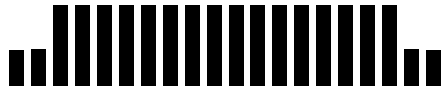

Cardio Run is a steady pace workout

but at a higher intensity than “Long Slow Distance”. Cardio Run is a more advanced workout, designed to motivate you to achieve a more challenging steady pace and maintain that pace for the full duration of the workout.

Cardio Run is a great workout if you are training for a special event.

### Short Interval 2

(20 minute default)

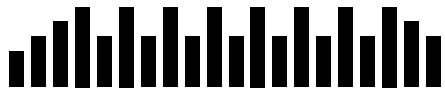

Short interval workouts have been

found in research studies to be ideal

for those striving to lose weight and improve cardiovascular fitness. Varying exercise intensity from a moderately slow level to a high intensity for a set period of time and repeating that progression for a complete workout will maximize the number of calories burned. The short interval recovery periods allows the body to more successfully exercise at a higher intensity than might otherwise be comfortable for a complete workout duration.

### Uphill Walk

(30 minute default)

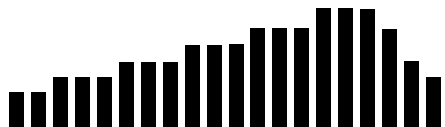

The uphill walk gradually increases the intensity of your exercise

peaking at a high intensity. The goal of the uphill workout is to stimulate your body to improve overall cardiovascular fitness, while also maximizing muscle cell development. The Uphill Walk has been designed to start slow and gradually increase to a peak intensity then with a quick decrease back to a recovery level. You will maximize calorie burn during the peak intensity levels while allowing your body to exercise for longer periods.

## Custom User Set-up Programs

There are 2 user programs that provide you with the ability to establish customized program profiles specific to your workout requirements. Once these programs are completed they are saved by the console and can be selected like any other preset program. Complete the following steps to set up a user program:

- A. **Select USER1 or USER2 Programs** – Press the Speed +/- buttons to select the USER1 or USER2 programs then press Enter.

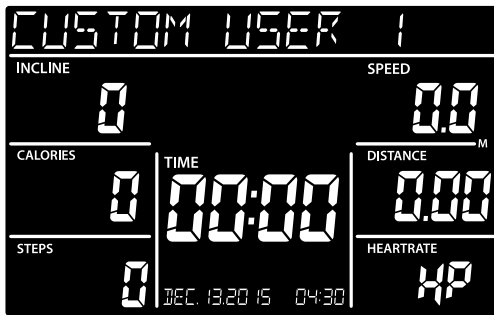

- B. **Set Time** – Set the program Time of your workout pressing the Speed +/- buttons then press Enter.

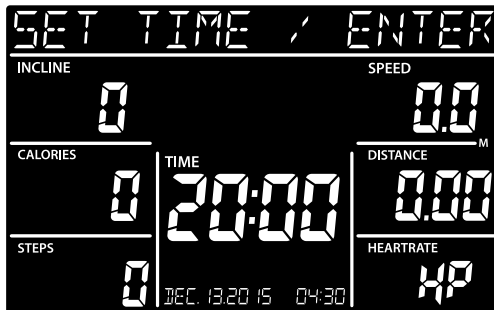

## Operations

- C. **Set Weight** – Set your Weight in the console for more accurate calorie calculation by pressing the Speed +/- buttons then press Enter.

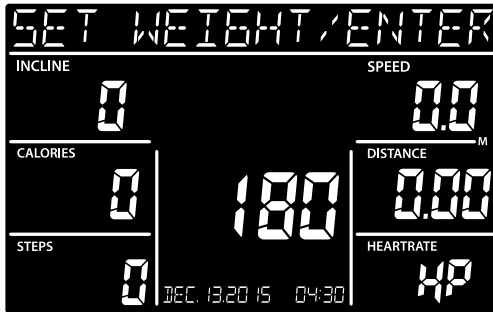

- D. **Set Level** – Use the Incline up/down buttons to set the incline level of the first program segment and the Speed +/- buttons to set the desired speed of the first program segment. You can also use the Quickset™ buttons for Incline and Speed to expedite the process. Press Enter.

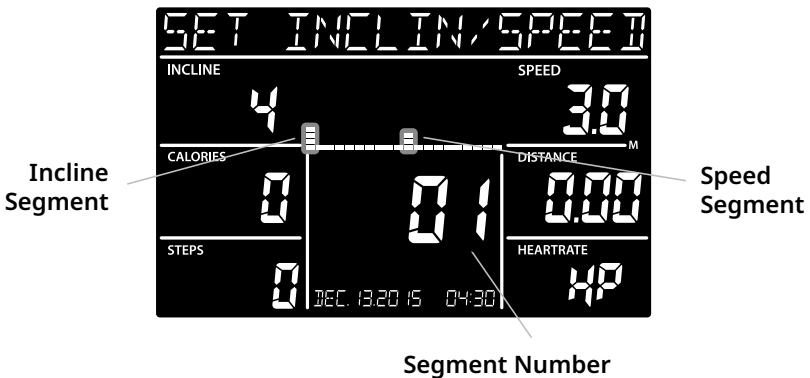

- E. **Repeat** – Repeat Step D until the 20 segments are complete. The twentieth segment will be shown in the Time window as shown below.

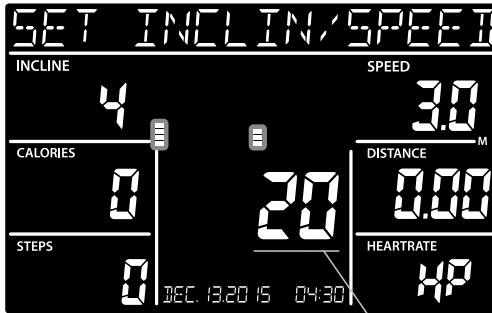

Segment Number

Once the program has been set up, simply scroll to the USER1 or USER2 program and press Start. Both Incline and Speed are shown in the program matrix with the Incline on the left and the Speed on the right.

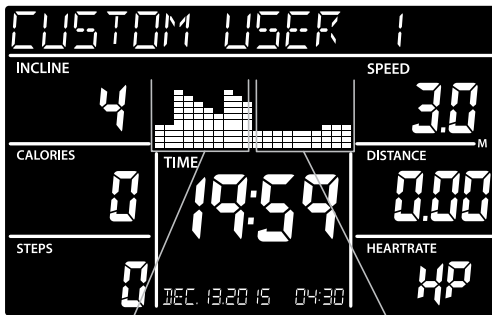

Incline Matrix

Speed Matrix

## Operations

### Using Heart Rate Control Programs

Two heart rate control programs are available on your console: Constant and Interval. When using these programs the console will need to receive your heart rate throughout the entire workout. Please review the Monitoring your Heart Rate section of this Owner's Manual for more information.

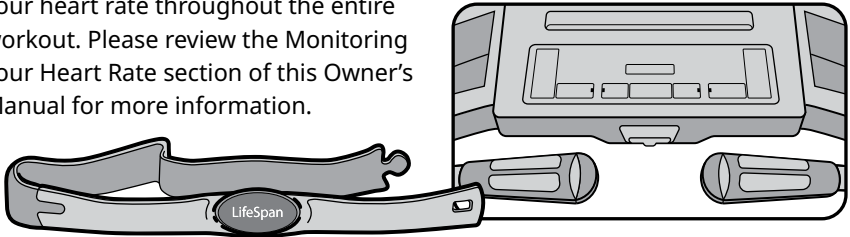

### HRC - Constant

The Constant Heart Rate program lets you select a single heart rate that you want to maintain throughout your workout and the treadmill will maintain this heart rate for you by either adjusting the speed or incline.

After selecting the HRC Constant program the next selection option will be Incline Mode or Speed Mode. Select which mode you prefer and the treadmill will adjust the speed or incline every 10 seconds to keep you at your selected heart rate level. For instance, if you select the incline mode, there will be a 3-minute warm-up and then the incline will start to adjust each 10 seconds to obtain and maintain your target heart rate. You choose the speed that you want the belt to run and the treadmill will control the incline.

#### To use this program:

- A. **Select HRC Constant** – Press the Speed +/- buttons to select the HRC Constant program, then press Enter.
- B. **Select Program Mode** – Select either the Incline Control Mode or the Speed Control Mode by pressing the Speed +/- buttons, then press Enter.
- C. **Set Time** – Set the program Time by pressing the Speed +/- buttons then press Enter. The program will include 3-minutes of warm up.
- D. **Set Weight** – Enter your Weight by pressing the Speed +/- buttons then press Enter.
- E. **Set Age** – Enter your Age by pressing the Speed +/- buttons, then press Enter.
- F. **Set Target Heart Rate** – Set your target heart rate by pressing the Speed +/- buttons then press Enter.
- G. **Press the Start Button** to begin your workout.

## HRC – Interval

The Interval Heart Rate program is designed to help you increase anaerobic endurance and improve heart rate recovery. The program lets you select both a High target heart rate and a Low recovery heart rate.

After a 3-minute warm-up, the console will adjust the incline or speed (your choice) every 10 seconds until you reach your High target heart rate. It will keep you there for 2 minutes. Then it will adjust incline or speed every 10 seconds to reduce your heart rate to your Low recovery level, then keep you there for 2 minutes. This repeats until the end of your workout.

It is recommended that you set the workout time to 30 minutes or longer to use this program effectively.

### To use this program:

- A. **Select HRC Interval** – Press the Speed +/- buttons to select the HRC Interval program then press Enter.
- B. **Select Program Mode** – Select either the Incline Control Mode or the Speed Control Mode by pressing the Speed +/- buttons then press Enter.
- C. **Set Time** – Set the program Time by pressing the Speed +/- buttons then press Enter. Remember the program will include 3 minutes of warm-up.
- D. **Set Weight** – Enter your Weight by pressing the Speed +/- buttons then press Enter.
- E. **Set Age** – Enter your age by pressing the Speed +/- buttons then press Enter.
- F. **Set High Target Heart Rate** – Set your High interval training rate by pressing the Speed +/- buttons, then press Enter.
- G. **Set Low Target Heart Rate** – Set your Low interval training rate by pressing the Speed +/- buttons, then press Enter.
- H. **Press the Start Button** to begin your workout.



**WARNING:** Heart rate monitoring may be inaccurate. Over exercising may result in serious injury or death. If you feel faint stop exercising immediately.

## Maintenance and Tips

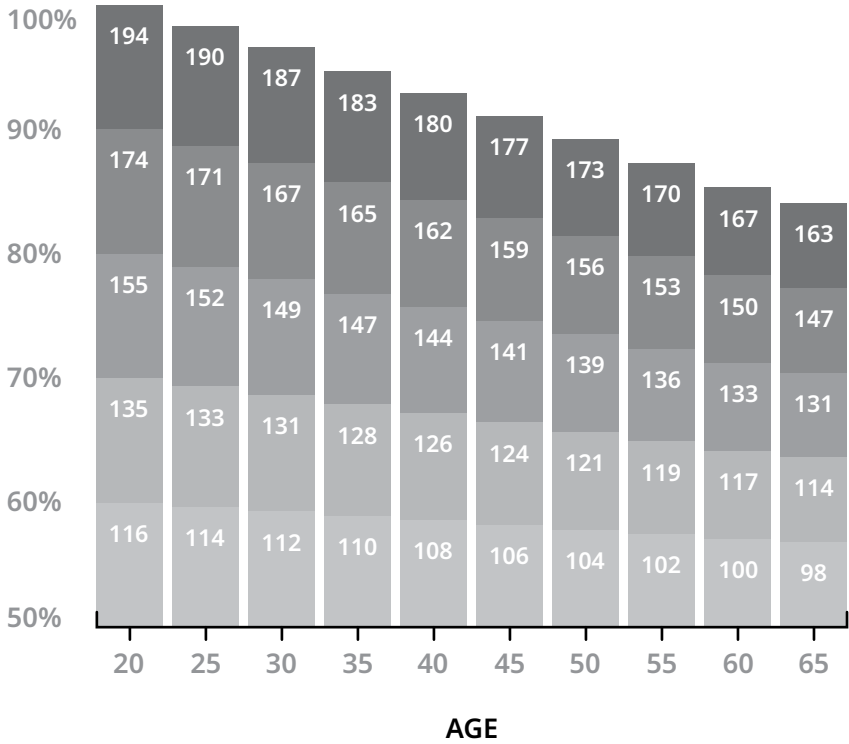

## Heart Rate Monitoring

Seeing your heart rate while exercising will help you understand the intensity of your exercise and corresponding heart rate training zone, and predict health benefits found through repeated bouts of exercise. Refer to the following information to understand your heart rate training zones:

### **Zone 5 — Performance Redline Zone: 90% - 100% of your Max HR**

The performance zone involves extreme effort, requiring the heart to beat at or near maximum capacity. Training bouts include intense incline or sprinting, benefitting speed, power, and anaerobic performance competency.

### **Zone 4 — Threshold Zone: 80% - 90% of your Max HR**

The threshold zone involves intense jogging or sub-maximal sprinting, typically unsustainable for long periods of time. Benefits include highly-elevated calorie burn, speed and power performance enhancement, improved lactate removal capabilities, and enriched heart health.

### **Zone 3 — Aerobic Zone: 70% - 80% of your Max HR**

The aerobic zone is ideal for cardiovascular training. Workouts in this zone are more intense, involving moderate jogging. Long-term benefits are improved heart health and cardiovascular performance, reductions in blood pressure and cholesterol, and increased calorie burn.

### **Zone 2 — Temperate Zone: 60% - 70% of your Max HR**

The temperate zone consists of moderate-intensity exercise, typically as fast walking to slow jogging. Speaking is more difficult and breathing is elevated. Benefits are similar to those of the healthy heart rate zone, though caloric expenditure is .

### **Zone 1 — Healthy Heart Zone: 50% - 60% of your Max HR**

The healthy heart zone involves safe, low-intensity activity, like medium-to-brisk walking. Full conversations can be held, despite a gentle increase in respiration. Benefits include reduced risk of heart and vascular disease, moderated blood pressure and cholesterol, and improved insulin sensitivity.



## Maintenance and Tips

### Hand Pulse Sensors

To use, grasp the sensors with a comfortable grip, with the palms of your hands placed over the sensors. If the sensors are having difficulty picking up your heart rate, use aloe or a moisturizer on your hands or further warm up as you exercise to increase the moisture in your hands. Dry hands do not transfer your pulse as effectively as moist hands.

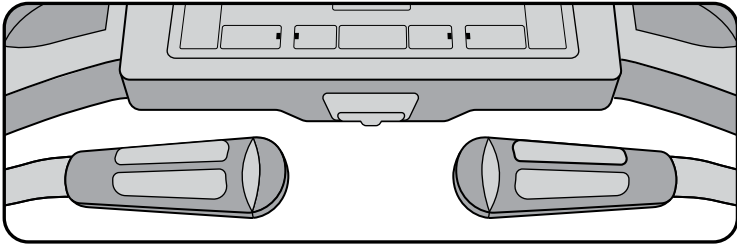

### Chest Strap

Both of the treadmill models covered in this Owner's Manual have integrated heart rate receivers built into the console.

The chest strap should be worn as shown. When using a chest strap you may need to warm up first to increase the moisture in your skin. If this doesn't work use aloe or another moisturizer where the sensors on the chest strap are making contact with your skin.

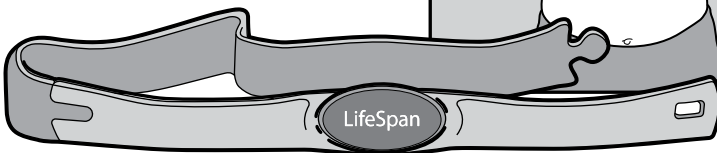
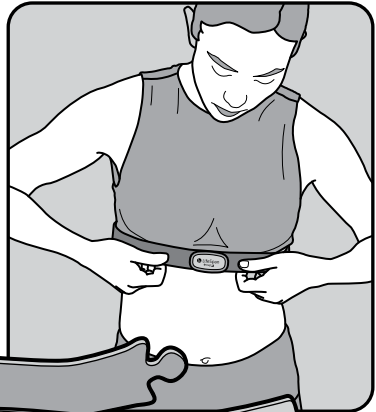

**Note:** The heart rate monitoring system will vary due to your age, method of use, physiology and other factors. LifeSpan cannot guarantee the accuracy of the heart rate readings.

### Cleaning

#### Daily

It is recommended to wipe the treadmill down after each use to keep the treadmill clean and dry. A mild detergent may be used at times to help remove all dirt and salt from the belt, painted parts and the display.

#### Monthly

This cleaning would include removing the motor cover and cleaning around the motor and electronics. It is recommended to clean the motor compartment if the treadmill is in an area where there might be plush carpet fibers that could get pulled up into the motor compartment. It is a good idea at this time to check and tighten all assembly hardware, power cord for damage, or anything else that would indicate the need for service.

#### Safety and Integrity

The safety and integrity designed into the machine can only be maintained when the treadmill is regularly examined for damage and repaired. Worn or damaged components shall be replaced immediately or the treadmill be removed from service until the repair is made. Pay special attention to components most susceptible to wear.



**WARNING:** Keep treadmill stable on flat ground.  
Over-exercising or inadequate training may result in physical injury.



**WARNING:** Unplug the power cord before removing the motor cover.



**IMPORTANT:** If service is required, turn the power off and remove the power cord to ensure the unit cannot be used. Let all other users know the unit needs service.



**CAUTION:** Acidic cleaning detergents may damage painted or powder coated surfaces and should not be used. Such cleaners may void the LifeSpan warranty.

## Maintenance and Tips

### Belt Lubrication

Use only 100% silicone and avoid using aerosol silicone sprays which include additives and petroleum distillates. One ounce of silicone should be used for each application. LifeSpan offers 100% silicone lubricant that can be ordered at [www.LifeSpanFitness.com](http://www.LifeSpanFitness.com).

The walking belt should be lubricated every 50 hours of use or three months.

To lubricate, unplug your treadmill.

1. Start toward the front of the treadmill, slide your hand under the belt and lift it away from the deck.
2. Slide tube under the belt as close to the center as possible.
3. Apply controlled pressure to the squeeze bottle as you slowly pull back the tube towards the belt edge.
4. Repeat on opposite side. (Use 1/2 oz. per side)
5. Use treadmill for 3-5 minutes to disperse lube.

**Note:**

When lubricating the belt, make sure the treadmill is on a surface that can be easily cleaned. After lubricating clean any excess silicone off the walking surface of the belt and side rails.



For a full video demonstration on lubricating your treadmill, scan the QR code to watch our YouTube video.

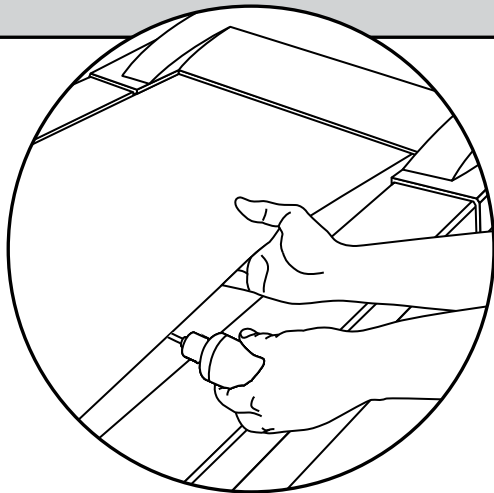

## Maintenance and Tips

### Folding the TR2000e /TR3000e Treadmill

- A. Make sure nothing is on or near your treadmill which might spill, be knocked over, or prevent the treadmill from moving. Make sure there are two feet of clearance between the front of the treadmill and any objects.
- B. Press and hold the STOP button to reset the console to Standby mode.
- C. Press and hold the eFOLD Up button on the console until the console beeps and shows "up/efold" in the display.
- D. Step back from the treadmill and wait till it is finished folding.

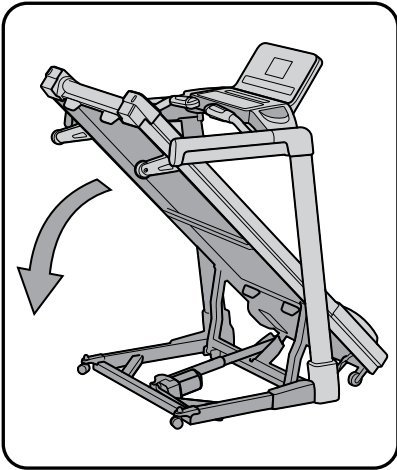

- E. Simply roll the treadmill to the desired location.

**Note:**

If for any reason you need to stop the treadmill from folding simply press the STOP button or pull the safety key.

### Un-Folding the TR2000e/TR3000e

- A. Make sure nothing is on or near your treadmill which might spill, be knocked over, or prevent the treadmill from lowering.
- B. Make sure to keep all pets and children away from the treadmill while lowering.

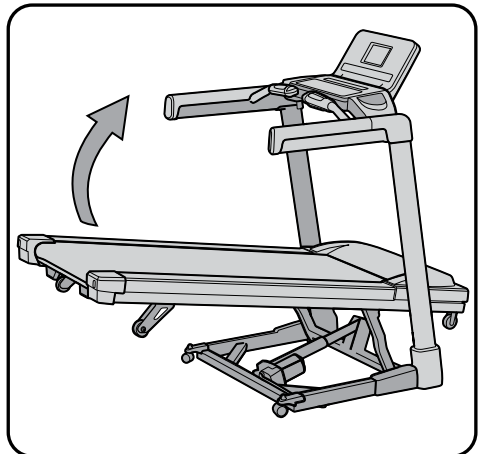

## Maintenance and Tips

**Note:**

This treadmill is equipped with sensors to stop the treadmill from lowering if anything gets in the path of the sensors. If for any reason you need to stop the treadmill from lowering manually, simply press the STOP button or pull the safety key.

- C. Press and hold the eFOLD Down button on the console until the console beeps and shows (down/efold) in the display.
- D. Step back from the treadmill and keep the area clear until the treadmill is fully lowered.
- E. Resume normal use of the treadmill.

## Moving the TR2000e/TR3000e Treadmill

The treadmill is not designed to be moved while in the unfolded position.

- A. Follow the previous instructions to bring the treadmill to the upright and folded position. This will place the treadmill onto its caster wheels, allowing for easy movement.
- B. Make sure the On/Off switch is turned off and the power cord is removed from the wall.
- C. Facing the console, push evenly on the treadmill's horizontal handlebars to maneuver the unit to its eventual storage location.

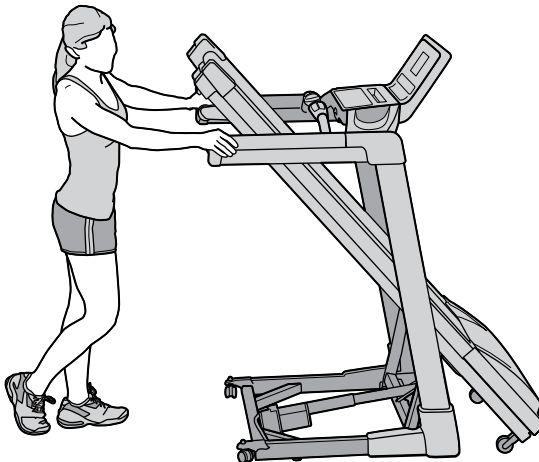

### Belt Tensioning

If the belt begins to slip and needs to be tensioned, there are tension bolts that are accessible from the back of the treadmill. Before tensioning the belt, start the treadmill and set the speed to 3 mph (5 kph).

- A. Using a 6 mm Allen wrench, included in your hardware bag, turn the right and left tension bolts 1/2 turn clockwise.
- B. Test to see if the slipping is eliminated. If the belt slips repeat Step A and test again.

**Note:**

Adjusting one side more than the other will cause the belt to drift to the side of the treadmill and will require belt alignment. Check to be sure the running belt is still aligned. If belt alignment is off as shown below refer to Belt Alignment section.

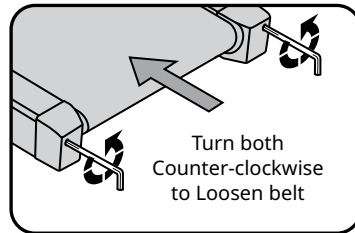
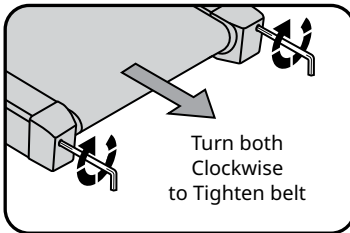

**CAUTION: DO NOT** tighten more than 2 full turns on each side.

Over tensioning the belt can cause unnecessary friction and wear and tear on the belt, motor and electronics.

## Maintenance and Tips

### Belt Alignment

- A. Press Start, then increase the treadmill speed to 3 mph (5 kph).
- B. Stand at the rear of the treadmill to see which way the belt is drifting.
- C. If the belt drifts to the left, turn the left adjustment bolt one-quarter turn clockwise and the right adjustment bolt one-quarter turn counter-clockwise. (See FIG. 1)
- D. If the belt drifts to the right, turn the left adjustment bolt one-quarter turn counter-clockwise and the right adjustment bolt one-quarter turn clockwise. (See FIG. 2)
- E. Observe the tracking for two minutes. Repeat steps A-D as needed.

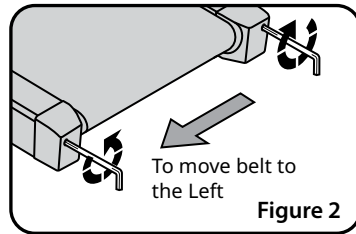
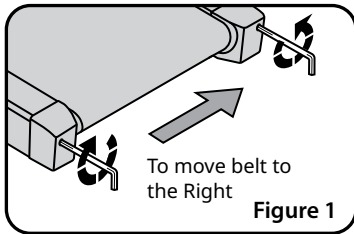

Visit [www.LifeSpanFitness.com](http://www.LifeSpanFitness.com) for a full video demonstration on the aligning your treadmill belt.

### Troubleshooting

If you have a question that isn't answered in this Owner's Manual, visit our website at [www.LifeSpanFitness.com](http://www.LifeSpanFitness.com) or call us at 801-973-9993 x4.

The treadmill is designed and manufactured to be reliable and easy-to-use. However, if you have a problem, these troubleshooting steps may help you find the cause.

**Problem: The console does not turn on or function correctly.**

Solution: Check to make sure the treadmill is properly plugged in, turn the power switch down by the power cord off and back on again and make sure the safety key is in place. Check all wire harness connections made during assembly to be sure they are all properly connected. If the problem persists contact LifeSpan Customer Service at [www.LifeSpanFitness.com](http://www.LifeSpanFitness.com) or call 801-973-9993 x4.

**Problem: The POWER button on the console does not turn the console on.**

Solution: Check the main power switch and power cord located at the front of the treadmill on the right side. Make sure the power cord is plugged in and the power switch is turned on.

**Problem: The treadmill does not turn off with the console power button.**

Solution: The console has to be in standby mode to be turned off with this button. Press and hold the Stop button till the console resets and then the POWER button will turn the console off.

**Problem: The belt does not stay in the center of the treadmill when in use.**

Solution: First check to make sure that the treadmill is level, then refer to the instructions in this Owner's Manual on how to align the belt.

**Problem: The treadmill belt slips during use.**

Solution: The belt may need to be tensioned after a period of use. Refer to the Belt Tensioning Section of this Owner's Manual.



## **Maintenance and Tips**

### **Problem: Heart rate is erratic or not reading.**

Solution: Make sure your hands are moist (aloe vera helps). Make sure all connections made during assembly, at the back of the console, are properly connected and no wires are damaged. If wearing a chest strap, be sure the batteries are good and that the electrodes are moist and positioned properly on your chest.

### **Problem: Treadmill automatically pauses during workout.**

Solution: The treadmill is not detecting your steps because you have stopped walking or because the user weight is too low to detect the steps, especially at an incline. One option would be to go to personal settings and turn Intelli-Guard off.

### **Problem: E1 Error Code after 3 to 8 seconds.**

Solution: This is most likely a bad wire connection or a speed sensor issue. Check all wire connections made during assembly and if this does not resolve the issue contact LifeSpan Customer Service at [www.LifeSpanFitness.com](http://www.LifeSpanFitness.com) or call 801-973-9993x4.

### **Problem: E1 Error Code after several minutes of use.**

Solution: This problem usually occurs when there is too much friction building between the running belt and deck. The best thing to do is turn the treadmill off, lubricate the running belt and turn the treadmill back on. Test the unit. If E1 still comes up after testing, contact LifeSpan Customer Service at [www.LifeSpanFitness.com](http://www.LifeSpanFitness.com) or call 801-973-9993 x4.

### **Problem: E6 Error Code.**

Solution: Turn the power off for 30 seconds and back on again. Check to see if the incline is functioning. If still an issue, please check all wire connections made during assembly and cycle the power again. If still not functioning contact LifeSpan Customer Service at [www.LifeSpanFitness.com](http://www.LifeSpanFitness.com) or call 801-973-9993x4.

**Problem: Treadmill will not fold or unfold.**

Solution: Make sure the treadmill is in Standby mode. Press and hold the Stop button for 3 seconds till the console resets. Once the console resets, press and hold the fold or unfold button until the console beeps and the folding or unfolding process starts. If trying to unfold the treadmill, make sure nothing is blocking the safety sensor underneath the treadmill which would prevent the treadmill from lowering.

# **TR2000e / TR3000e**

Electric Folding Treadmills

---

## **LifeSpan Fitness**

785 West 1700 South Suite 1

Salt Lake City, UT. 84104

Phone: 877.654.3837

[www.LifeSpanFitness.com](http://www.LifeSpanFitness.com)

**Version 2.0**