

TR100 / TR200

LifeSpan™

MyTread

Owners Manual

LifeSpan™

by PCE
HEALTH & FITNESS

Welcome to LifeSpan

Congratulations in taking a step forward to increase your level of physical activity or add variety to your current exercise program. Physical activity is now more than ever a necessity to keep your body healthy and fit. Whether your motivation is to Lose Weight, manage a Chronic Disease like diabetes, train for a sporting event or just live a Healthy Lifestyle, LifeSpan products can help you achieve your health and fitness goals.

We invite you to the LifeSpan Fitness website at www.LifeSpanfitness.com where we include additional information and tools to help you maintain your exercise program and achieve your health and fitness goals.

The LifeSpan Home series of cardio equipment is designed for the more than 60% of consumers who say they prefer to exercise in the comfort and privacy of their own homes. Each Home series product is designed and manufactured to exceed your expectations for quality and durability, simple assembly and ease of operation.

Please read this manual thoroughly before assembly and operation of your new LifeSpan equipment. It includes information on proper operation, safety precautions, product assembly and ongoing maintenance.

Remember that some types of services should only be performed by a qualified service technician. In the instance that service is required, please contact your authorized LifeSpan retailer or log on to our website and select the Customer Support option. Complete the information requested and we will respond to your inquiry within 1 business day.

785 West 1700 South
Salt Lake City, UT. 84104
Phone: 801.973.9993 x4
www.LifeSpanFitness.com

Neither PCE Health and Fitness nor its representatives can accept responsibility for any damages or injury incurred as a result of information presented in this manual except under the terms of the product warranty.

Table of Contents

• Welcome	3
• Specifications	5
• Limited Home User Warranty	6
• Important Safety Precautions	7
• Starting an Exercise Program	8
• Assembly Instructions	9
• Treadmill Leveling	11
• Console Overview	12
• Treadmill Operations	14
• Reading your Heart Rate	16
• Program Overview	17
• Moving and Storage	21
• Maintenance and Belt Lubrication	23
• Troubleshooting	24
• Engineering Mode	25
• Belt Tension and Alignment	26
• Extended Warranty	27
• Serial Number Information	28

Specifications

	TR100	TR200
<p>Console Readouts</p> <p>Display Program Matrix</p> <p>Programs</p> <p>Audio</p>	<p>Workout Time, Calories, Distance, Heart Rate, Speed</p> <p>Blue backlit LCD 8 Rows by 12 Columns</p> <p>Manual, Preset (5)</p> <p>MP3 and Headphone Jacks</p>	<p>Workout Time, Calories, Step Count, Distance, Heart Rate, Speed, Incline</p> <p>Blue backlit LCD 8 Rows by 12 Columns</p> <p>Manual, Preset (6), User Set-up (1), Heart Rate Control (1)</p> <p>MP3 and Headphone Jacks</p>
<p>Mechanics and Performance</p> <p>Speed Range</p> <p>Incline Levels</p> <p>Running Belt Size</p> <p>Deck</p> <p>Drive Motor</p> <p>Lift Motor</p> <p>Maximum User Weight</p> <p>Dimensions</p>	<p>1.0 - 6.0</p> <p>NA</p> <p>16" x 47"</p> <p>0.75" Phenolic Deck</p> <p>1.5 HP Continuous Duty</p> <p>250 lbs</p> <p>60" L x 31" W x 52" H</p>	<p>1.0 - 6.0</p> <p>0 - 10</p> <p>16" x 47"</p> <p>0.75" Phenolic Deck</p> <p>1.5 HP Continuous Duty</p> <p>650 lb. Max Lift Rating 250 lbs</p> <p>60" L x 31" W x 52" H</p>
<p>Residential Warranty</p> <p>Frame</p> <p>Parts</p> <p>Labor</p>	<p>10 Years</p> <p>2 Years</p> <p>1 Year</p>	<p>10 Years</p> <p>2 Years</p> <p>1 Year</p>

Limited Home Use Warranty

The LifeSpan TR100 and TR200 Folding Treadmills come with the following limited warranty, which applies only for the use of the Treadmill in the home, for residential, non-commercial purposes.

Frame	10 Years
Parts	2 Years
Labor	1 Year

PCE Health and Fitness warrants that the equipment it manufactures is free from defects in material workmanship under normal use and service. The periods above are based on the date of purchase. During these periods, PCE Health and Fitness will repair or replace any defective part. Free labor is included for the first year on all parts that are not normally assembled or replaced by the customer. Customer may be responsible to pay for Service Technician travel time where travel in excess of 20 miles is required.

If within the time frames specified above, any part fails to operate properly, log on to our web site at www.lifespanfitness.com and click on Customer Support and complete the form to request assistance. Or call 801-973-9993 x4 for a customer support agent.

PCE Health and Fitness reserves the right to make changes and improvements to our products without incurring any obligations to similarly alter any product purchased. In order to insure our product warranty and to ensure the safe and efficient operation of your LifeSpan product, only authorized parts can be used. The warranty is void if any parts other than those provided by PCE Health and Fitness are used.

Exclusions and Limitations:

- This warranty does not apply to any defects caused by negligence, misuse, improper assembly or maintenance, accident, or an "act of god".
- This warranty does not apply to discoloration of paint or plastics.
- PCE Health and Fitness shall not be responsible for incidental or consequential damages.
- This warranty is nontransferable from the original owner.
- Labor warranty does not cover replacement of Customer Assembled Parts.

Registration

You must register your LifeSpan product before a warranty claim can be processed. To complete your registration online go to www.lifespanfitness.com and click on Register Products, or fill out the warranty card provided and mail it today. Registration cards must be received by PCE Fitness within 30 days of purchase to activate the Product Warranty. Product Warranties are not valid unless the registration is properly completed and received within 30 days.

Important Safety Precautions

When using exercise equipment, basic precautions should always be followed, including:

- Never drop or insert any object into any opening.
- Never operate this treadmill if it has been damaged or even partially submersed in water.
- To reduce the risk of electric shock, unplug the treadmill from the wall outlet when not in use, before performing any maintenance, or before moving the treadmill.
- Do not use outdoors.
- Do not lean against or climb on the treadmill. Doing so may result in the treadmill tipping and falling and could result in serious personal injury.
- Do not hang or place items on the treadmill. Doing so could result in shifting the weight balance of the treadmill causing it to tip over or fall causing serious personal injury.
- Do not operate with the side rails removed.
- Keep the treadmill on a solid surface, with the side rails and front a minimum of two feet from any walls or furniture. Make sure that the area behind the treadmill remains completely clear during use. A minimum of 4 feet of clearance is required for safety reasons.
- Do not operate where aerosol spray products are being used or where oxygen is being administered.
- Never place the power cord under carpeting or place any object on top of the cord, this may pinch or damage the cord causing fire damage or personal injury.
- Use this exercise product for its intended use as described in this Owner's Manual. Do not use attachments that are not recommended by PCE Heath and Fitness.
- Do not leave your treadmill running while not in use.

Children and Pets

- Keep children off your treadmill at all times.
- When in use children and pets should be kept at least 10 feet away.

Grounding Instructions

- Never use extension cords between the treadmill and the wall outlet.
- This product is for use on a nominal 120 volt (non GFI) circuit, and has a grounding plug similar to the illustration below. Never remove or otherwise bypass the electrical ground terminal.

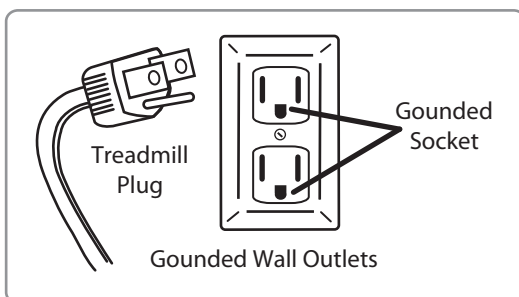

Danger: Improper connection of the equipment grounding conductor can result in the risk of electric shock. Check with a qualified electrician or service person if you are in doubt as to whether the product is properly grounded. Do not modify the plug provided with the product. If it will not fit in the outlet, have the proper outlet installed by a qualified electrician.

Other Safety Tips

- Always consult a physician before beginning this or any exercise program.
- If you experience chest pains, nausea, dizziness or shortness of breath, stop exercising immediately and consult your physician before continuing.
- Do not wear clothing or jewelry that might catch on any part of the treadmill.
- This treadmill is equipped with a safety key. If the key is removed from the display, the treadmill will immediately stop. Always clip the cord that is attached to the safety key to a part of your clothing so the key will be pulled from the display, stopping the treadmill, in case of an emergency.

Starting an Exercise Program

Starting an exercise program can sound like a daunting task, but just remember that your main goal is to boost your health by meeting the basic physical activity recommendations.

Before you begin an exercise program or substantially increase your level of activity, be sure to consult your primary care physician. In preparation for a visit you may also want to take the PAR-Q Assessment. This Physical Activity Readiness Questionnaire (PAR-Q) will help you determine your suitability for beginning an exercise program and prepare you for discussing your physical activity program with your physician.

1. Has your doctor ever said that you have a heart condition or that you should participate in physical activity only as recommended by a doctor?
2. Do you feel pain in your chest during physical activity?
3. In the past month, have you had chest pain when you were not doing physical activity?
4. Do you lose your balance because of dizziness?
5. Do you ever lose consciousness?
6. Do you have a bone or joint problem that could be made worse by a change in your physical activity?
7. Is your doctor currently prescribing drugs for your blood pressure or a heart condition?
8. Do you know of any reason you should not participate in physical activity?

If you answered yes to one or more of the questions, if you are over 40 years of age and have been inactive, or if you are concerned about your health, consult a physician before beginning an exercise program or substantially increasing your physical activity. If you answered no to each question, then it's likely you can begin an exercise program.

Pre-Exercise Resting Heart Rate Check

Before beginning your exercise program it is recommended that you check your resting heart rate. Your resting heart rate should be taken in a seated, relaxed position. Find your resting pulse and begin your count with "zero" on the first heart beat. Continue counting each time you feel your pulse until you have counted for a full 30 seconds. Next, double the number that you counted for 30 seconds and you now have your pre-exercise resting heart rate. Remember this number as we also recommend taking a post-exercise resting heart rate after you have completed your exercise program and you will want to remember your pre-exercise heart rate so you can compare the two heart rate measurements.

Assembly

At LifeSpan we strive to make our equipment easy to assemble and start using. The TR100 and TR200 model treadmills come completely assembled in the box and are ready to operate in just minutes.

Step 1: Remove Treadmill from Box

- Remove strapping and box lid.
- Cut four corners of box and lay the sides down.
- Remove tape and packaging foam from top of treadmill.
- Lift back of treadmill up and slide treadmill out of the box.

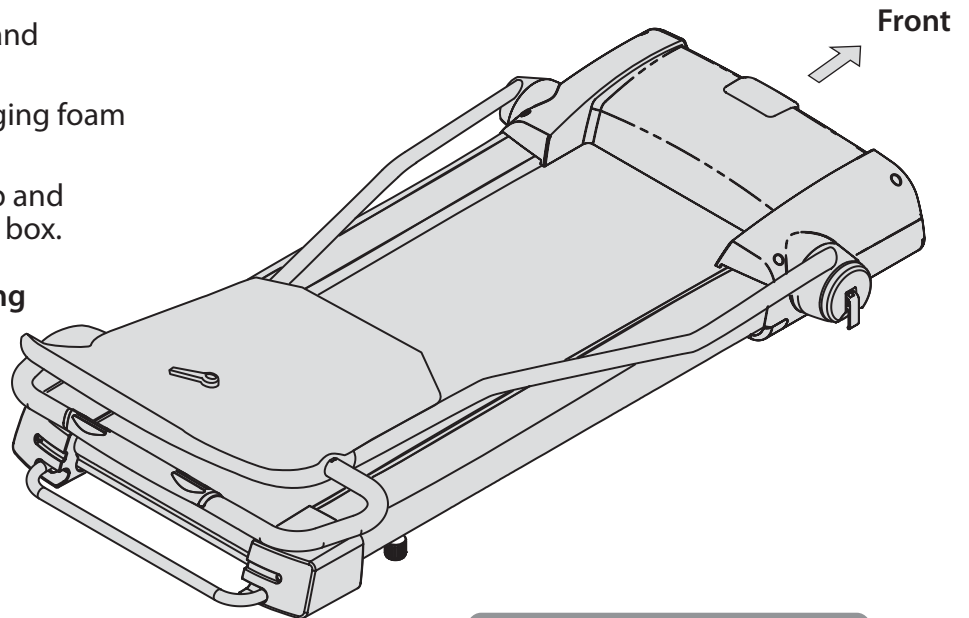

Step 2: Remove Bag and Packaging Material from Treadmill

Step 3: Stand up the Console

- Rotate the blue round cap on each side at the bottom of the post 1 full turn counterclockwise to release any pressure on the locking mechanism.

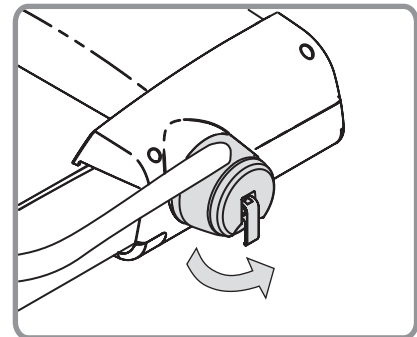

- Pull out the quick release lever on the same round cap. Repeat on the opposite side.

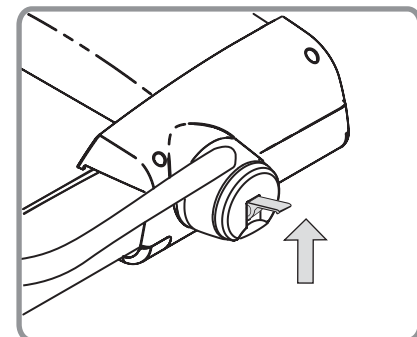

- C. Raise the handlebar and console support to the upright position.

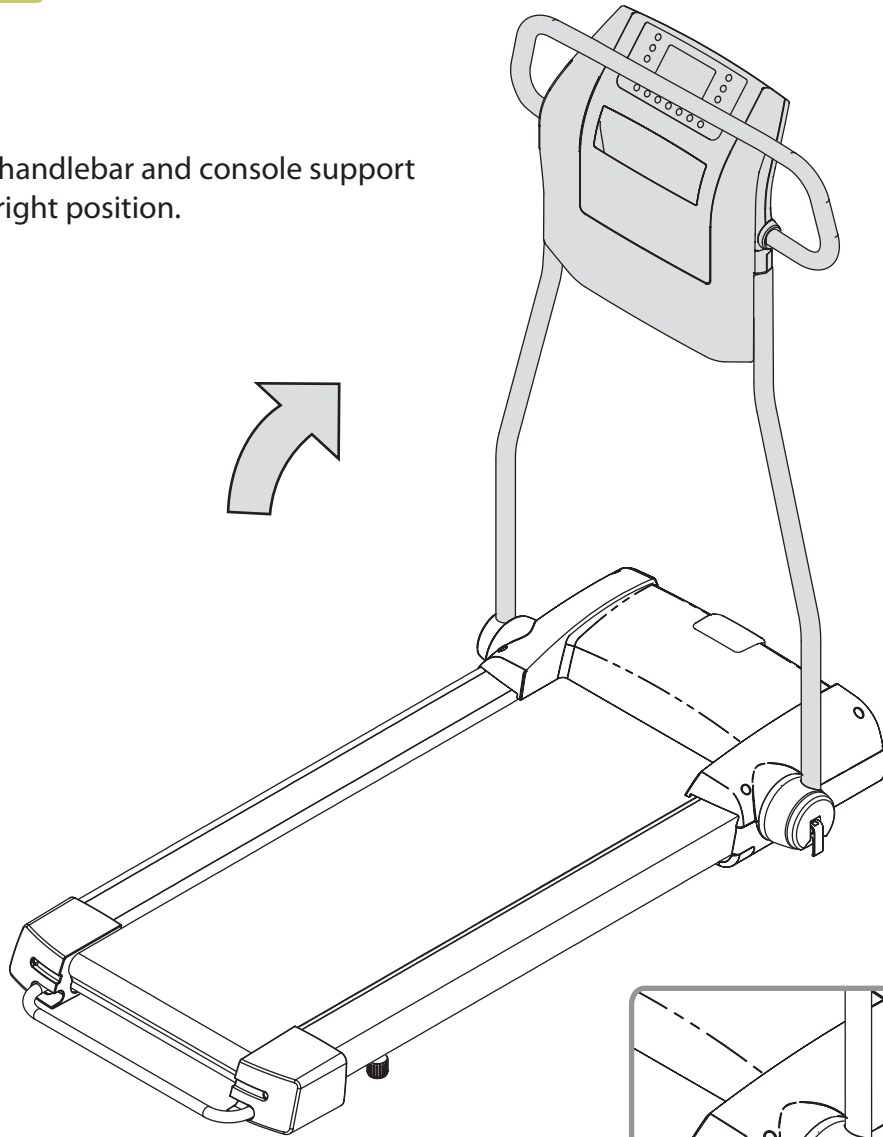

- D. Press in the quick release lever to lock handlebar and console support in place. If the quick release lever does not press in easily turn the blue round cap counterclockwise 1/2 turn. Repeat if lever does not press in easily.

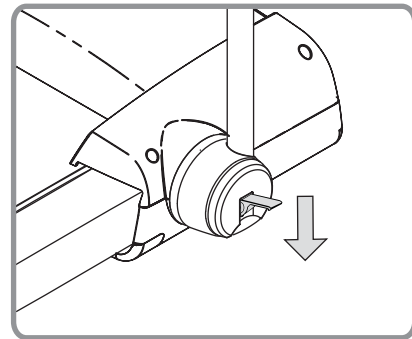

- E. Turn the blue round cap clockwise to tighten and secure the joint. Repeat on the opposite side.

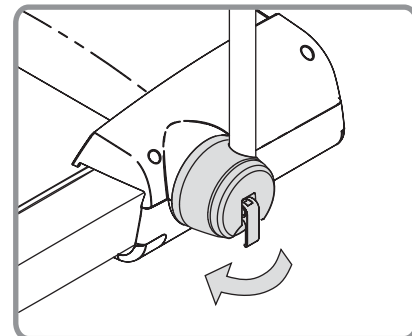

Caution: Injury to the user could occur if lever is not pushed into the locked position and cap is not securely tightened. This could result in handlebar and console support falling onto the treadmill platform.

Step 4: Lock the Handlebar in Place

- A. Make sure the lever on the back of the console is in the unlock position (Fig. 1).
- B. Rotate the handlebar down until it stops (Fig. 2).
- C. On the back side of the console lock the handlebar in place by turning the handle to the locked position (Fig. 3).

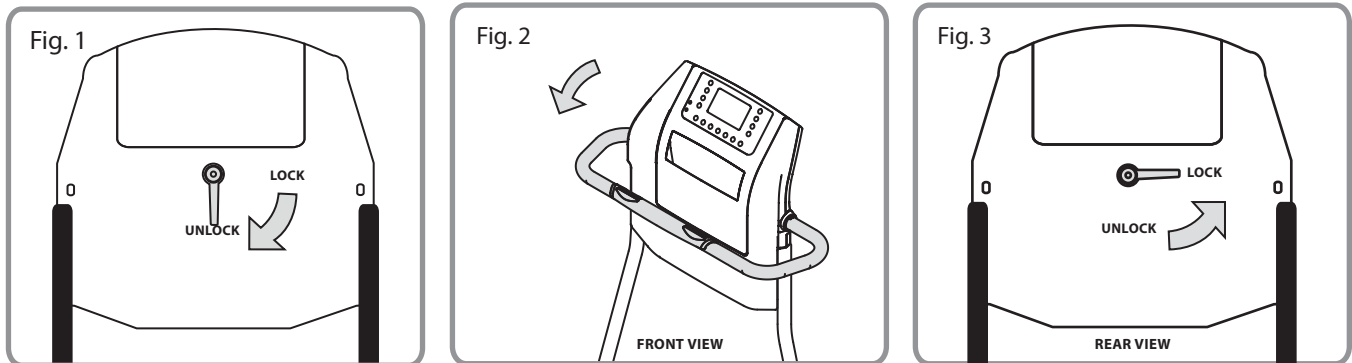

Step 5: Install the Safety Key (Red Key with Yellow Clip located in owners manual packet)

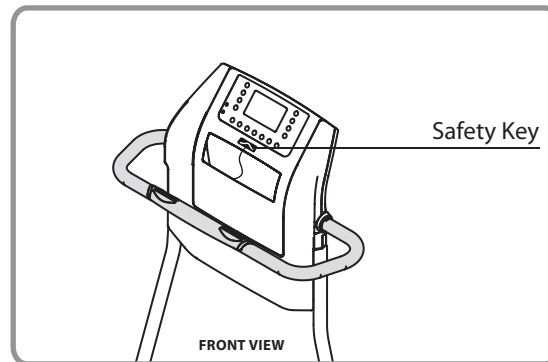

Leveling the Treadmill

For optimum performance the treadmill should be level. To level the TR100 and TR200 model treadmills use the adjustable feet underneath the back of the treadmill. Loosen the lock nut on each foot and unscrew the feet to the desired height making sure that the treadmill sits stable and even on the floor. Tighten each lock nut.

Adequate Space

Make sure you have room to lay the treadmill down. There needs to be at least 2 feet of clearance on both sides and in the front of the treadmill. There should be at least 4 feet of clearance on the back side of the treadmill for safety reasons. If the user were to fall this would give adequate clearance to get off the treadmill.

Moving

The treadmill is equipped with transport wheels located in front. To move, lift up on the back end of the frame. Relocate the treadmill by rolling the treadmill on these wheels.

Display Console

TR100

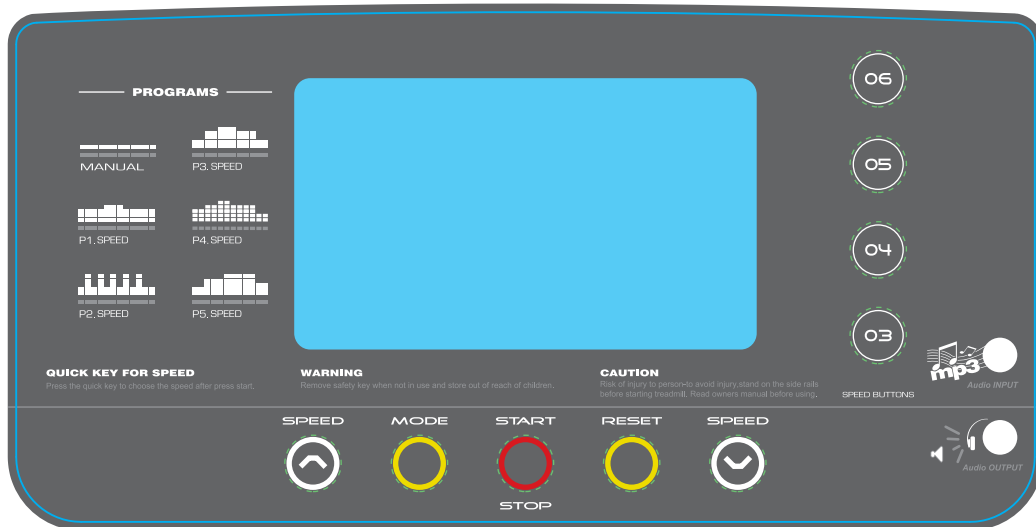

TR200

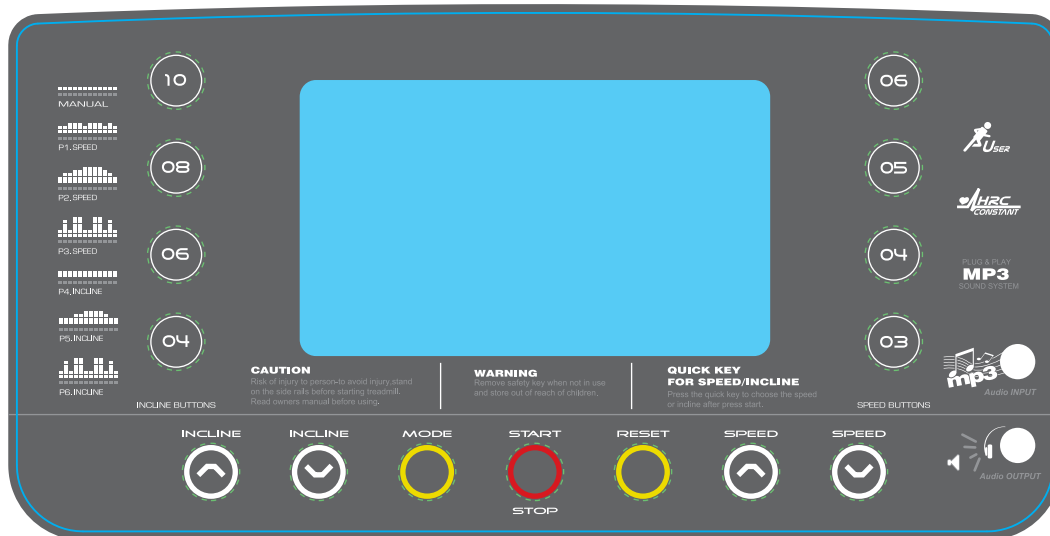

Start / Stop: Press the START button to begin a Manual workout without having to set any individual information. When the program begins your workout time will start counting up from 00:00 and you can manually adjust the incline (TR200 only) or speed as you exercise. If you need to temporarily stop your workout, press the START button to PAUSE. To RESTART the workout, press the START button. When your workout is completed, the console will reset after 30 seconds.

Reset: Press the reset button to exit your exercise program or restart program set up.

Mode: The MODE button is used to Select each piece of information needed during program setup including Program and Workout Level. On the TR200, it will change the display reading between the incline and heart rate.

Display Console (Continued)

Speed Control Buttons: The up and down arrows for Speed control are used to modify the value of each selection during the program set up and to adjust the speed of the walking belt during use.





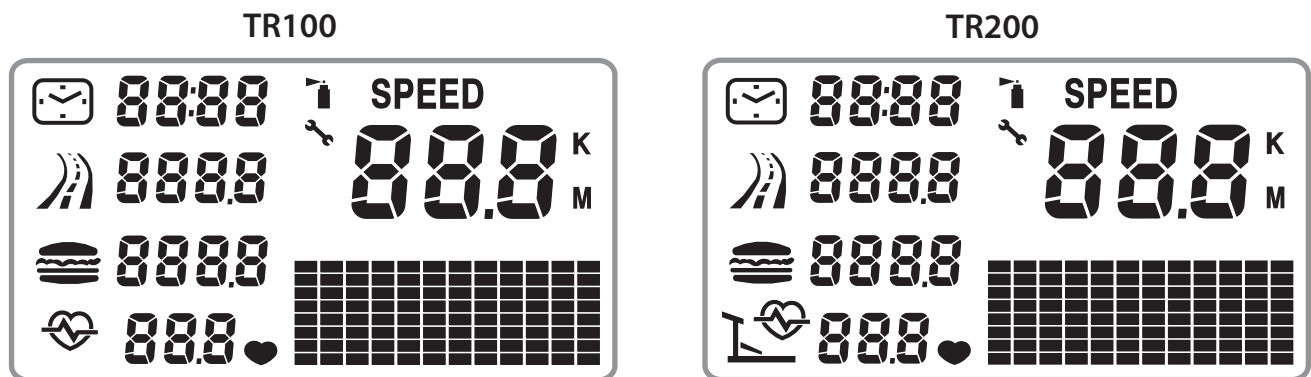

Incline Control Buttons (TR200 only): Up and Down arrows for incline control are used to adjust the incline of the walking belt during use.

Quick Select Buttons: The TR100 and TR200 come with 4 quick select buttons for speed and the TR200 also includes 4 quick select buttons for incline. These buttons allow you to quickly jump directly to the desired speed or incline rather than requiring that you scroll to get to the value.

Display Screen



Workout Feedback: The TR100 and TR200 display window will simultaneously display the following workout information:

-  **Time:** The workout time elapsed or the workout time remaining
-  **Incline (TR200 only):** The level of belt incline ranging from 0-10
- M** **Speed:** The speed you are traveling in Miles Per Hour (this reading can be changed to Kilometers by using the Engineering Mode)
-  **Calories:** Estimated calories burned since the beginning of the workout
-  **Distance:** Total distance traveled in miles or kilometers since the beginning of the workout
-  **Pulse:** Your measured heart rate using the Contact Heart Rate sensors located on the handlebars
-  **Lubrication:** This icon turns on when it is time to apply silicone lubricant to the running belt
-  **Maintenance:** This icon turns on when it's time to clean and check all hardware on the treadmill

For more information on Lubrication and Maintenance please see page 23.

Operating Your Treadmill

Starting in Manual

The quickest way to get started is to press the START button. Pressing the START button will start the treadmill in the Manual program and the TIME will start counting up from 00:00. You can also press Speed Up/Down button to select M for Manual program. Using the Mode button will allow you to set a specific workout TIME.

Setting Time in Manual Mode

Insert the safety key and press the Speed Up/Down buttons until "M" is displayed at the bottom of the screen. Press the Mode button and the time begins flashing. Press the Speed Up/Down button to set the desired workout time. Press Start and the time will count down from the set time. Press Start/Stop button to pause your workout and press it again to resume workout. Press the Reset button to reset the console.

Starting a Preset Program TR100 (5 Preset Speed Programs)

1. Insert the safety key and press the Speed Up/Down buttons until the desired program is displayed (P1 to P5).
2. Press the Mode button and use the Speed Up/Down buttons to select a level (L1 to L3).
3. Press the Mode button and press the Up/Down button until the desired time is set.
4. Press the Start button. The treadmill will start and the count down from the set time.

Starting a Preset Program TR200 (3 Preset Speed and 3 Incline Programs)

1. Insert the safety key and press the Speed Up/Down buttons until the desired program is displayed (P1 to P6). The first 3 are Speed programs and the next 3 are Incline programs.
2. Press the Mode button and use the Speed Up/Down buttons to select a level (L1 to L3).
3. Press the Mode button and press the Up/Down button until the desired time is set.
4. Press the Start button. The treadmill will start and then count down from the set time.

Custom User Set-up Program (TR200 only)

This program allows the user to preset the speed and incline levels for a personalized workout.

Custom User Program Setup

User Mode must be set up before using. To set up the User Mode:

1. Insert the safety key and press the Speed Up/Down buttons to get the user program (U1).
2. Press the Mode button to select the speed and incline for Segment 1. Use the Speed Up/Down buttons to set the speed. Use the Incline Up/Down buttons to select the incline level.
3. Press Mode and repeat step 2. Continue to press Mode and set the desired speed and incline levels for all 12 Segments.
4. Press the Mode button and the time will flash. Use the Speed Up/Down button to set the time (default time: 24 minutes).
5. Press the Start button to begin your workout.

Once the program has been set up, simply scroll to the USER1 program and press START.

Constant Heart Rate Control Program (TR200 only)

The constant Heart Rate Control (HRC) program requires that you set a heart rate the display console will maintain throughout the workout. The “constant” program lets you select a single heart rate that you will maintain throughout your workout and the treadmill will maintain this heart rate for you by adjusting the speed and the incline. There is a 3 minute warm up before the actual program starts.

Note: To use the Heart Rate Control programs the treadmill needs to receive your heart rate throughout the entire workout by using the Contact Heart Rate sensors.

Typically for Weight Loss set the target heart rate at 65% of your predicted maximum heart rate and for Cardio Training set the target at 80% of your predicted maximum.

Constant Heart Rate Control Program Setup

1. Insert the safety key and press the Speed Up/Down buttons until HRC is displayed in the console.
2. Press the Mode button and use the Speed Up/Down buttons to set the desired workout time
The default time is 24 minutes.
3. Press the Mode button and use the Speed Up/Down buttons to set up your correct age.
4. Press the Mode button and use the Speed Up/Down Buttons to select the Target Heart Rate.
5. Press the Mode button and use the Speed Up/Down buttons to set the Max. speed.
6. Press the Mode button and use the Speed Up/ Down buttons to set the Max. Incline.
7. Press the Start button, the treadmill will run through a 3 minute warm up at 2 MPH and incline to level 5. After the 3 minute warm up the treadmill will start to change speed and incline to get your heart rate to your Target Heart Rate.

Note: If the treadmill does not pick up your heart rate within 30 seconds after the warm up period the treadmill will stop for safety reasons.

Operations

While exercising you can change the Speed and Incline Level by pressing the UP / DOWN buttons. To pause your exercise program press the START button and to reset your program, press the Reset button

Reading Your Heart Rate

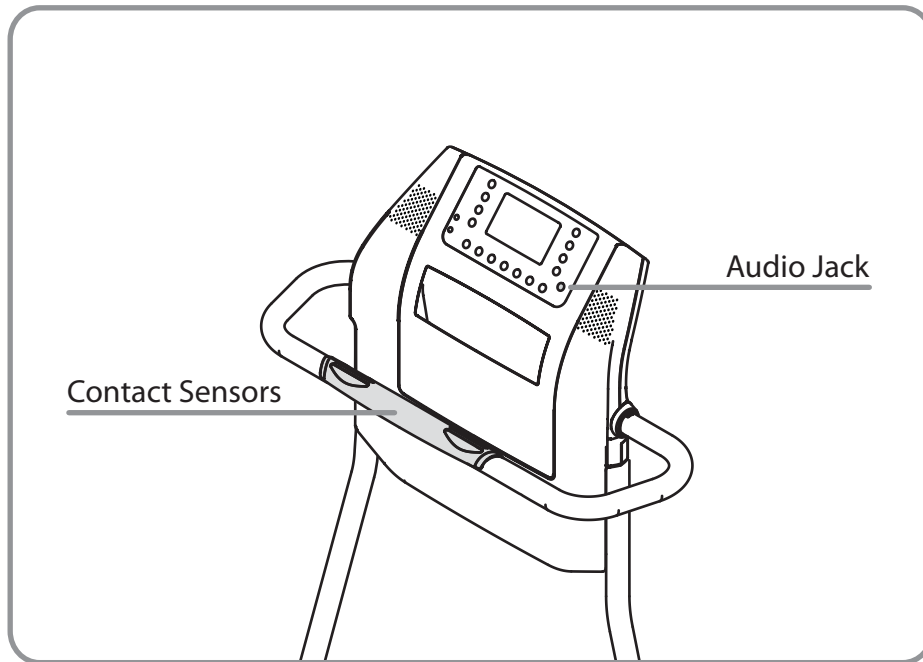

Contact Heart Rate Sensors are built into the stationary hand grips of the TR100 and TR200 to monitor your heart rate during exercise. To use, grasp the sensors with a comfortable grip, with the palms of your hands placed over the sensors. If the sensors are having difficulty picking up your heart rate you may consider using aloe or a moisturizer on your hands or you can warm up as you exercise to increase the moisture in your hands. Dry hands do not transfer your pulse as effectively as moist hands.

Do not squeeze tightly as this can cause your blood pressure to rise. It will take a few seconds for the console to calculate your heart rate accurately.

Audio Package: Included are audio in and audio out jacks to use with MP3 players or other audio devices with standard input jacks and also an output jack to use headphones.

Note: Volume is controlled by your mp3 or other audio device.
There are no volume controls on the console.

Program Overview

The preset programs default to 24 minute workout time but you can adjust these times during program set up. You can also select from 3 different intensity levels during the program set up.

The TR100 comes with 5 programs that control the speed of the walking belt during your program to vary the effort required during your workout.

The TR200 comes with 3 programs that control the speed and 3 programs that control the level of incline to vary the effort required during your workout.

TR100 Preset Programs (Km/h)

P1: Long Slow Distance - Speed

Km/h	1	2	3	4	5	6	7	8	9	10	11	12
L1	2.5	2.5	3.0	3.5	3.5	4	3.5	3.5	3	3	2.5	2.5
L2	3	3	3.5	4	4.5	4.5	4.5	4	3.5	3.5	3	3
L3	4	4	4.5	4.5	4.5	5.5	4.5	4.5	4.5	4	4	4



P2: Interval - Speed

Km/h	1	2	3	4	5	6	7	8	9	10	11	12
L1	2	5	2	5	2	5	2	5	2	5	2	2
L2	3	6	3	6	3	6	3	6	3	6	3	3
L3	3.5	6.5	3.5	6.5	3.5	6.5	3.5	6.5	3.5	6.5	3.5	3.5



P3: Pyramid - Speed

Km/h	1	2	3	4	5	6	7	8	9	10	11	12
L1	2	2	3	4	4.5	5	4.5	4	3	3	2	2
L2	3	3	4	4.5	5	6	5	4.5	4.5	4	3	3
L3	3.5	3.5	4.5	5.5	6	6.5	6	5.5	4.5	4.5	3.5	3.5



P4: Speed Walk - Speed

Km/h	1	2	3	4	5	6	7	8	9	10	11	12
L1	3	3	4	4	5	5	4	4	3	3	2	2
L2	3.5	3.5	4.5	4.5	6	6	4.5	4.5	4	4	3	3
L3	4	4	5.5	5.5	6.5	6.5	5.5	5.5	4.5	4.5	3.5	3.5



P5: Speed Walk - Speed

Km/h	1	2	3	4	5	6	7	8	9	10	11	12
L1	2	2	3	3	4	4.5	5.5	5.5	4.5	4.5	3.0	3.0
L2	3.0	3.0	4	4	4.5	5	6	6	5	5	3	3
L3	3.5	3.5	4.5	4.5	5.5	6	6.5	6.5	6	6	4	4



TR100 Preset Programs (MPH)

P1: Long Slow Distance - Speed

MPH	1	2	3	4	5	6	7	8	9	10	11	12
L1	1.5	1.5	1.8	2.1	2.1	2.5	2.1	2.1	1.8	1.8	1.5	1.5
L2	1.8	1.8	2.1	2.5	2.8	2.8	2.8	2.5	2.1	2.1	1.8	1.8
L3	2.5	2.5	2.8	2.8	2.8	3.4	2.8	2.8	2.8	2.5	2.5	2.5



P2: Interval - Speed

MPH	1	2	3	4	5	6	7	8	9	10	11	12
L1	1.2	3.1	1.2	3.1	1.2	3.1	1.2	3.1	1.2	3.1	1.2	1.2
L2	1.8	3.7	1.8	3.7	1.8	3.7	1.8	3.7	1.8	3.7	1.8	1.8
L3	2.1	4	2.1	4	2.1	4	2.1	4	2.1	4	2.1	2.1



P3: Pyramid - Speed

MPH	1	2	3	4	5	6	7	8	9	10	11	12
L1	1.2	1.2	1.8	2.5	2.8	3.1	2.8	2.5	1.8	1.8	1.2	1.2
L2	1.8	1.8	2.5	2.8	3.1	3.7	3.1	2.8	2.8	2.5	1.8	1.8
L3	2.1	2.1	2.8	3.4	3.7	4	3.7	3.4	2.8	2.8	2.1	2.1



P4: Speed Walk - Speed

MPH	1	2	3	4	5	6	7	8	9	10	11	12
L1	1.8	1.8	2.5	2.5	3.1	3.1	2.5	2.5	1.8	1.8	1.2	1.2
L2	2.1	2.1	2.8	2.8	3.7	3.7	2.8	2.8	2.5	2.5	1.8	1.8
L3	2.5	2.5	3.4	3.4	4	4	3.4	3.4	2.8	2.8	2.1	2.1



P5: Speed Walk - Speed

MPH	1	2	3	4	5	6	7	8	9	10	11	12
L1	1.2	1.2	1.8	1.8	2.5	2.8	3.4	3.4	2.8	2.8	1.8	1.8
L2	1.8	1.8	2.5	2.5	2.8	3.1	3.7	3.7	3.1	3.1	1.8	1.8
L3	2.1	2.1	2.8	2.8	3.4	3.7	4	4	3.7	3.7	2.5	2.5



TR200 Preset Programs (Km/h)

P1: Rolling Hills - Speed

Km/h	1	2	3	4	5	6	7	8	9	10	11	12
L1	3	3	3.5	4.0	3.5	3	3.5	4.0	3.5	3	3.5	3
L2	3.5	3.5	4	4.5	4	3	4	4.5	4	3	4	3
L3	4	4	4.5	5	4.5	4	4.5	5	4.5	4	4.5	4



P2: Uphill Walk - Speed

Km/h	1	2	3	4	5	6	7	8	9	10	11	12
L1	3	3.5	4	4.5	5	6	6	6.5	6.5	5	4.5	3
L2	3.5	4	4.5	5	6	6	6.5	7.5	7.5	6.5	4.5	3.5
L3	4	4.5	5	6	6	7	7	7.5	7.5	6	5	4



P3: Long Interval - Speed

Km/h	1	2	3	4	5	6	7	8	9	10	11	12
L1	2	6	3	7	7	3	3	7	7	3	6	2
L2	3	6.5	3.5	7.5	7.5	3.5	3.5	7.5	7.5	3.5	6.5	3
L3	3.5	7.5	4	8.5	8.5	4	4	8.5	8.5	4	7.5	3.5



P4: Rolling Hills - Incline

Km/h	1	2	3	4	5	6	7	8	9	10	11	12
L1	2	2	3	4	3	2	3	4	3	2	3	2
L2	3	3	4	5	4	3	4	5	4	3	4	3
L3	4	4	5	6	5	4	5	6	5	4	5	4



P5: Uphill Climb - Incline

Km/h	1	2	3	4	5	6	7	8	9	10	11	12
L1	2	3	4	5	6	7	7	8	8	6	4	2
L2	3	4	5	6	7	8	8	9	9	7	5	3
L3	4	5	6	7	8	9	9	10	10	8	6	4

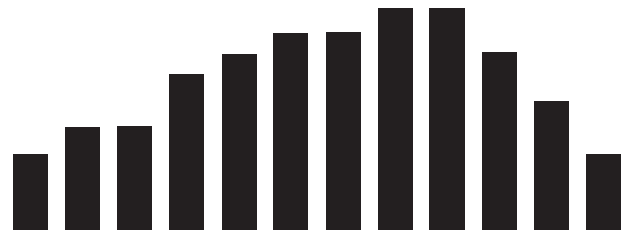

P6: Long Interval - Incline

Km/h	1	2	3	4	5	6	7	8	9	10	11	12
L1	1	6	2	8	8	2	2	8	8	2	6	1
L2	2	7	3	9	9	3	3	9	9	3	7	2
L3	3	8	4	10	10	4	4	10	10	4	8	3



TR200 Preset Programs (MPH)

P1: Rolling Hills - Speed

	1	2	3	4	5	6	7	8	9	10	11	12
L1	1.8	1.8	2.1	2.5	2.1	1.8	2.1	2.5	2.1	1.8	2.1	1.8
L2	2.1	2.1	2.5	2.8	2.5	1.8	2.5	2.8	2.5	1.8	2.5	1.8
L3	2.5	2.5	2.8	3.1	2.8	2.5	2.8	3.1	2.8	2.5	2.8	2.5



P2: Uphill Walk - Speed

	1	2	3	4	5	6	7	8	9	10	11	12
L1	1.8	2.1	2.5	2.8	3.1	3.7	3.7	4	4	3.1	2.8	1.8
L2	2.1	2.5	2.8	3.1	3.7	3.7	4	4.6	4.6	4	2.8	2.1
L3	2.5	2.8	3.1	3.7	3.7	4.3	4.3	4.6	4.6	3.7	3.1	2.5



P3: Long Interval - Speed

	1	2	3	4	5	6	7	8	9	10	11	12
L1	1.2	3.7	1.8	4.3	4.3	1.8	1.8	4.3	4.3	1.8	3.7	1.2
L2	1.8	4	2.1	4.6	4.6	2.1	2.1	4.6	4.6	2.1	4	1.8
L3	2.1	4.6	2.5	5.3	5.3	2.5	2.5	5.3	5.3	2.5	4.6	2.1



P4: Rolling Hills - Incline

	1	2	3	4	5	6	7	8	9	10	11	12
L1	2	2	3	4	3	2	3	4	3	2	3	2
L2	3	3	4	5	4	3	4	5	4	3	4	3
L3	4	4	5	6	5	4	5	6	5	4	5	4



P5: Uphill Climb - Incline

	1	2	3	4	5	6	7	8	9	10	11	12
L1	2	3	4	5	6	7	7	8	8	6	4	2
L2	3	4	5	6	7	8	8	9	9	7	5	3
L3	4	5	6	7	8	9	9	10	10	8	6	4

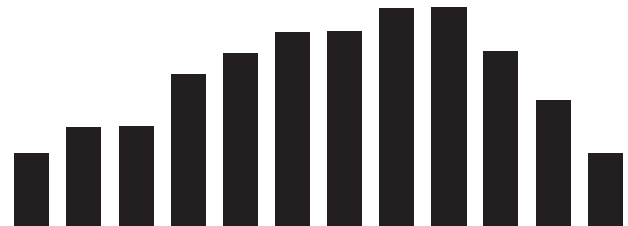

P6: Long Interval - Incline

	1	2	3	4	5	6	7	8	9	10	11	12
L1	1	6	2	8	8	2	2	8	8	2	6	1
L2	2	7	3	9	9	3	3	9	9	3	7	2
L3	3	8	4	10	10	4	4	10	10	4	8	3



Fold N Store

The TR100 / TR200 treadmills have been designed to give you a number of simple storage options. These treadmills can be folded and stored under a bed, tucked away in a corner or even stored in a closet.

Upright Storage

Step 1: Moving the Handlebar to the Upright Storage Position

A. On the back of the console, turn the Locking Handle clockwise to UNLOCK.

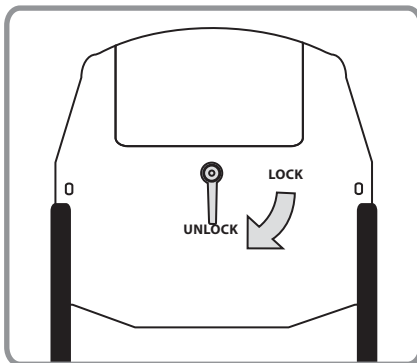

B. Lift the Handlebar upwards as shown below.

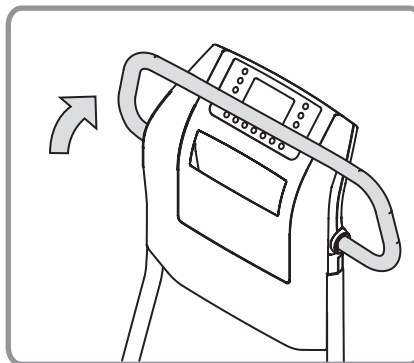

C. Turn the Locking Handle counterclockwise to the LOCK position.

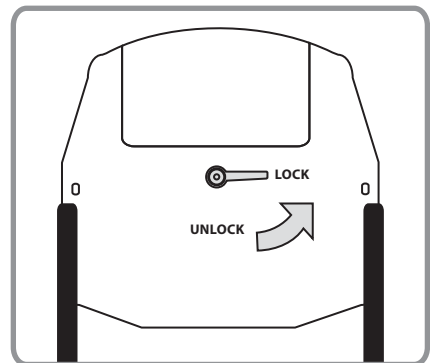

Step 2: Folding the Console Down to the Walking Surface

A. Rotate the blue round cap on each side 1 full turn counterclockwise to release any pressure on the locking mechanism (Fig. 1).

B. Release the Quick Release lever on the same round cap. Repeat on the opposite side (Fig. 2).

C. Fold the handlebar and console support down until it rests on the treadmill platform.

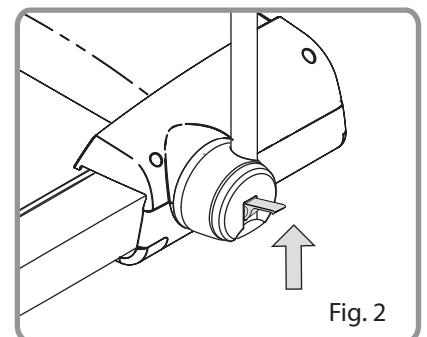
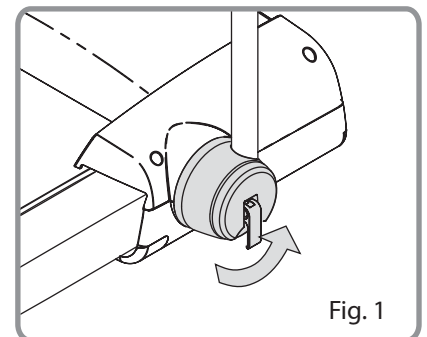
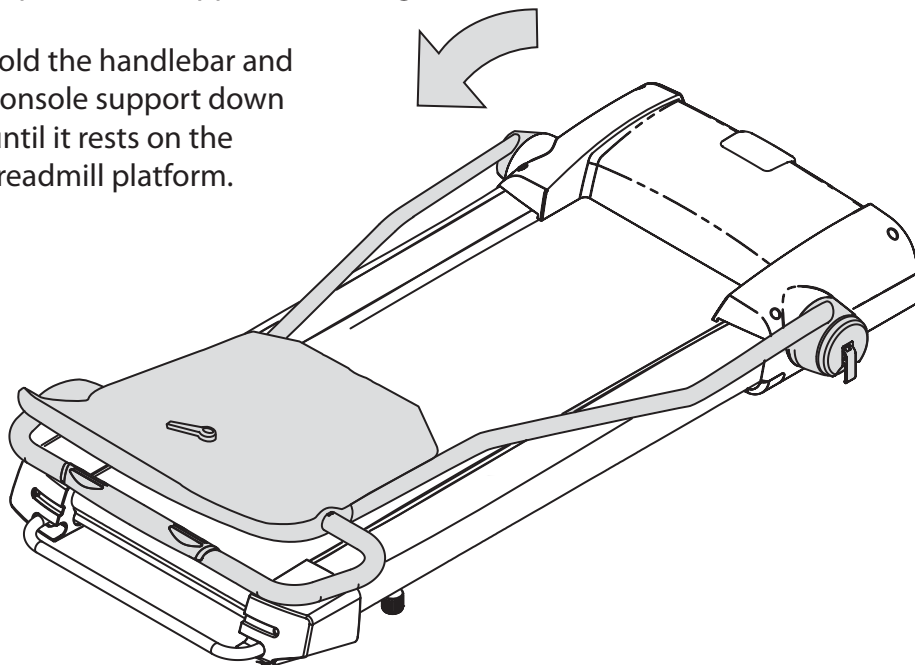

Step 2: (continued)

- D. Press in the Quick Release lever to lock the handbar and console support in place. If lever does not press in easily rotate the cap 1/2 turn counterclockwise. Repeat if needed.

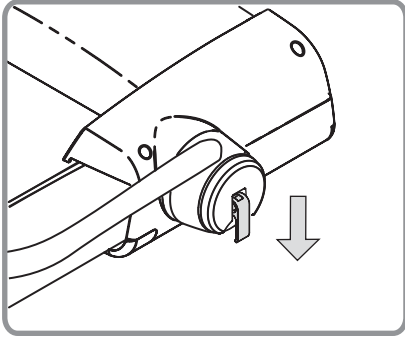

- E. Turn the blue round cap clockwise to tighten and secure the joint. Repeat on the opposite side.

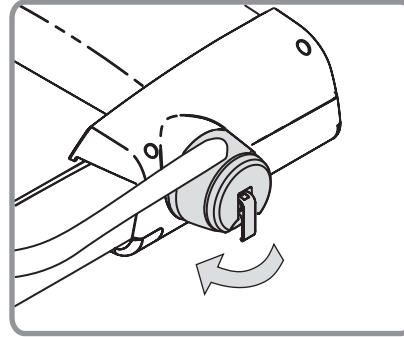

Step 3. Standing Up the Folding Treadmill

- A. Turn off the power switch located by the plug at the base of the treadmill. Unplug the power cord from both the wall and the treadmill.

- B. Pull up the blue extension foot located on the top of the hood. To pull the extension foot up, press the latch under the blue cap on the top of the extension foot and then pull the extension foot up until it locks.

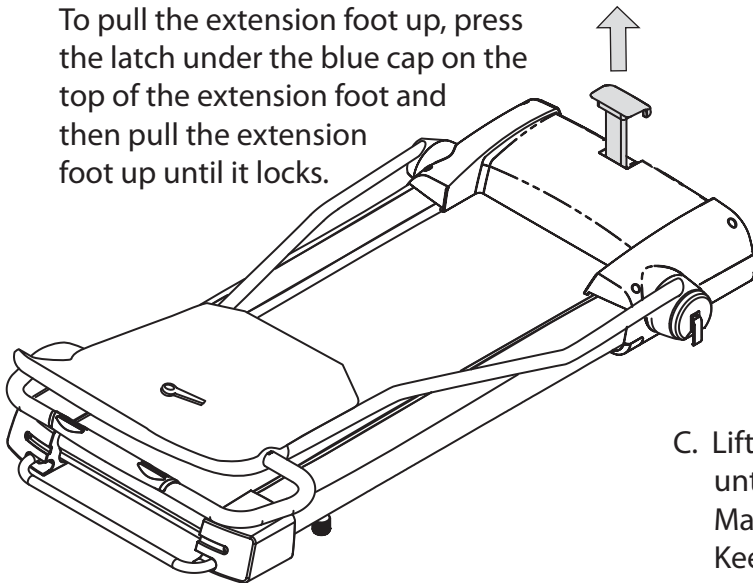

- C. Lift the back of the treadmill up until it rests on the extension foot. Make sure it is on a level surface. Keep treadmill safely stored out of reach of children.

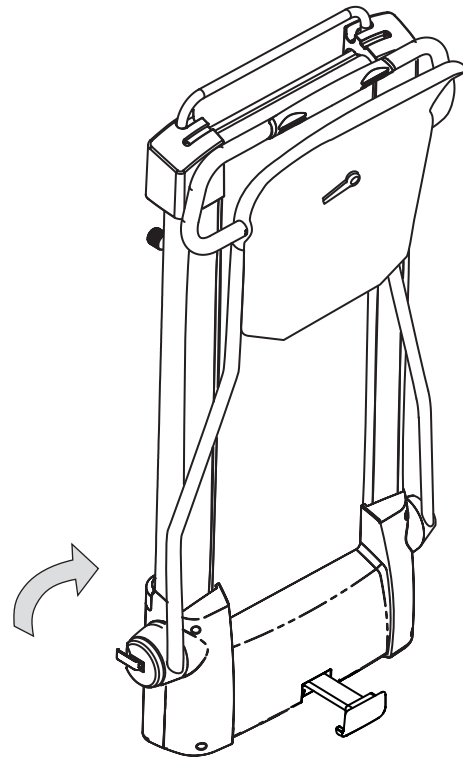

Note: The treadmill is equipped with transport wheels located in front. To move, lift up on the back end of the frame. Relocate the treadmill by rolling the treadmill on these wheels.

Belt Lubrication

Use only 100% Silicone and avoid using aerosol silicone sprays which include additives and petroleum distillates. One ounce of Silicone should be used for each application. LifeSpan offers 100% silicone lubricant that can be ordered at www.lifespanfitness.com.

The running belt should be lubricated every 3 months (regardless of use) or every 50 hours of use, whichever comes first. Even if the treadmill is not being used, silicone will dissipate over time and the belt will dry out.

Note: Even though the running belt is lubed from the manufacturer, you should lubricate the running belt when first using the treadmill in case the belt has dried some between the dates the unit was manufactured and when it was purchased.

The Silicone icon will turn on in the display every 100 hours of use and is a reminder that it is time to lubricate the running belt. As indicated above it is best to lubricate the running belt every 50 hours of use. This is a reminder for the 2nd 50 hours. The icon will be in the display for 5 minutes and then it will turn off. To turn the icon off, before the 5 minutes, you can press the SPEED DOWN and START buttons simultaneously until the icon turns off.

Apply the silicone to the underside of the treadmill belt. Do not apply to the walking surface. This may be accomplished by standing up the treadmill and applying the silicone to the inside portion of the belt. Spray the silicone down and across the belt. Rotate the belt 1/2 of the circumference and repeat. About one ounce of Silicone should be used for each application.

Note: When lubricating the belt, make sure the treadmill is located on a surface that can be easily cleaned. After lubricating your treadmill running belt, clean any excess silicone off the belt and frame.

Cleaning and Maintenance

It is recommended to wipe the treadmill down after each use to keep the treadmill clean and dry. A mild detergent may be used at times to help remove all dirt and salt from the belt, painted parts and the display.

The Maintenance icon shows up in the display every 150 hours of use. This is a reminder to clean the unit really well. This cleaning would include removing the motor cover and cleaning around the motor and electronics. It is recommended to clean the motor compartment if the treadmill is in an area where there might be a lot of pet hair or plush carpet fibers that could get pulled up into the motor compartment. It is a good idea at this time to check and tighten all assembly hardware as well.

Warning: Unplug the Power Cord Before Removing the Motor Cover.

After cleaning and checking all assembly hardware, turn the maintenance icon off, by pressing SPEED DOWN and START buttons simultaneously until the icon turns off.

Troubleshooting

The treadmill is designed and manufactured to be reliable and easy to use. However, if you have a problem, these troubleshooting steps may help you find the cause.

- Problem:** The console is erratic or not lighting up
Solution: Check to make sure that the treadmill is properly plugged in, turn the power switch off and back on again and make sure the safety key is in place. If the problem persists contact LifeSpan Customer Service (page 6).
- Problem:** The belt does not stay in the center of the treadmill when in use.
Solution: First check to make sure that the treadmill is level, then refer to the instructions in this manual on how to tension and adjust the belt (page 26).
- Problem:** The treadmill motor seems strained or E1 comes up after several minutes of use.
Solution: The lubricating silicone that is applied to the deck and belt is wearing down and the belt needs to be lubricated with silicone spray (page 23).
- Problem:** The treadmill belt slips during use.
Solution: The belt may need to be tensioned after a period of use. Refer to the Belt Tensioning and Adjustment Section of this manual (page 26).
- Problem:** Speed does not match quick keys. Treadmill Starts at 1.6 and goes to 10.
Solution: The treadmill is set up in Metric Mode. See chart on next page for Console Engineering Mode (page 25).
- Problem:** Heart Rate is erratic or not picking up.
Solution: Make sure your hands are moist (Aloe Vera helps), (page 16).
- Problem:** Silicone icon lights up on console.
Solution: Lubricate the running belt with 100% pure silicone. Then simultaneously press and hold the Speed Down and Start/Stop buttons until the light turns off (page 23).
- Problem:** Maintenance icon lights up on console.
Solution: This light indicates a scheduled cleaning and maintenance should be done. Please read the Cleaning section in this manual for details. To turn the icon off press the Speed Down and the Start/Stop buttons simultaneously (page 23).

Engineering Mode	Display View
(TR100) Press Reset + Speed Down button simultaneously and hold till display changes and shows Year and date. Pressing Start shows the software version.	2009 501 100 VER
(TR200) Press Reset + Speed Up button simultaneously and hold till display changes and shows Year and date. Pressing Start shows the software version.	2009 501 100 VER
Press Mode The console changes to show the Roller Diameter	500 ROL
Press Mode The LDU Version shows up in the display	500 LDU
Press Mode The ISP Version shows in the display	541 ISP
Press Mode This screen allows the user to change between Miles (M) or Kilometers (K). Press the up or down arrows to change between the two modes.	 KM / M
Press Mode This screen shows the Total Distance	0 010 KM / M
Press Mode This screen shows Total Hours	0 005 HRS
Press Reset + Mode This saves any changes and resets the console	

Belt Tensioning

If the belt begins to slip during use, it will need to be tensioned. Your treadmill is equipped with tension bolts that are accessible from the back of the treadmill. Before tensioning the belt, start the treadmill and set the speed to 3 MPH. Using a 6 mm Allen Wrench, included in your hardware bag, turn the right and left tension bolts 1/2 turn clockwise. After you adjust each side 1/2 turn, test to see if the slipping is eliminated. If the belt slips repeat this step and test again.

If you turn one side more than the other, the belt will start to drift to the side of the treadmill and will need to be aligned. **DO NOT** tighten more than 2 full turns on each side. If slippage still occurs, contact LifeSpan Customer Service.

Note: Over tensioning the belt can cause unnecessary friction and wear and tear on the belt, motor and electronics.

Aligning the Running Belt

Ensure the running belt is centered on your treadmill at all times. Running style and a non-level surface are two instances that may cause the belt to drift off center. Minor adjustments to the two bolts at the rear of the treadmill are necessary when the belt has drifted off center.

1. Press "START", then increase the treadmill speed to 3MPH.
2. Stand at the rear of the treadmill to determine which direction the belt is drifting.
3. If the belt drifts to the left, turn the left adjustment bolt one-quarter turn clockwise and the right adjustment bolt one-quarter turn counter-clockwise. (See FIG.C)
4. If the belt drifts to the right, turn the left adjustment bolt one-quarter turn counter-clockwise and the right adjustment bolt one-quarter turn clockwise. (See FIG.D)
5. Observe the tracking of the belt for about two minutes. Repeat steps 3, 4 and 5 as needed.

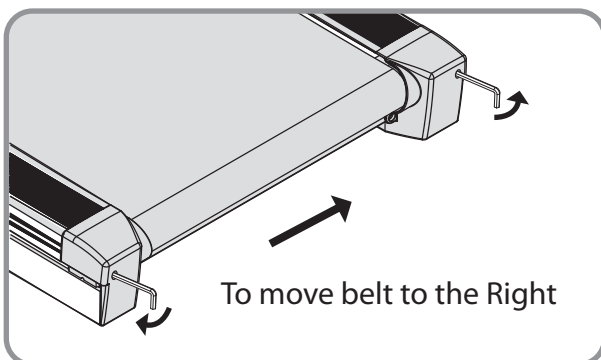

FIG C.

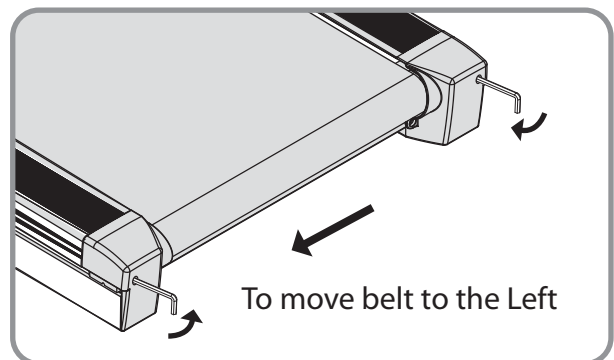

FIG D.

Treadmill Doctor

The Most Trusted Name In
Fitness Equipment

Extended Service Plans

360°
GUARANTEE

Up to **4 Years of Coverage**
for just **Pennies a Day**

Treadmill Doctor's 360 Degree Guarantee

Extended Service Plan program is a money saver for YOU!

- ✓ We will Extend your original Manufacturer's warranty for parts & labor coverage.*
- ✓ We will cover failures due to normal wear and tear.*
- ✓ We will replace your machine if we can't repair it.*
- ✓ We provide unlimited on-site visits!*
- ✓ We will cover failures due to power surges.
- ✓ Your coverage is transferable.
- ✓ Over 3,000 certified technicians.
- ✓ National toll-free repair hotline.
- ✓ Simple repair claim procedure & no claim forms.

Did You Know

a single repair can cost TWICE the amount of a 3 year service plan?

That is because a single repair is not one service trip it is two! One trip for the diagnosis and one for the repair after parts have been ordered.

Labor Cost	-\$260
Parts Cost	-\$170
Total Repair Cost	-\$430

3 Year Treadmill Doctor
Service Plan **\$169.99**

Get your 360 Guarantee NOW

ONE OF THE INDUSTRY'S BEST GUARANTEES!

Copyright © 2010. TreadmillDoctor.com, Inc. All rights reserved. Treadmill Doctor and 360 Degree Guarantee are registered trademarks of TreadmillDoctor.com, Inc. All rights reserved.

Enroll Now:

360guarantee.com/Lifespan

You will need the following information:

- Purchase Date*
- Model Number*
- Serial Number*
- Retailer/ Etailer Name
- * Required Field

Purchase Price	1 Year	2 Year	3 Year	4 Year
\$300-\$999	\$99.99	\$129.99	\$169.99	\$229.99
\$1000-\$1999	\$129.99	\$149.99	\$229.99	\$299.99
\$2000-\$2999	\$169.99	\$199.99	\$299.99	\$399.99
\$3000-\$3999	\$199.99	\$249.99	\$399.99	\$499.99
\$4000-\$4999	\$299.99	\$399.99	\$599.99	\$899.99

* Limitations and exclusions apply. See terms and conditions available online at 360guarantee.com/Lifespan for full agreement details.

Contract begins at the expiration of the manufacturer's labor warranty.



LifeSpan Fitness
785 West 1700 South
Salt Lake City, UT 84104

TREADMILL MODEL NUMBER- **TR100 / TR200**

SERIAL NUMBER :

MADE IN TAIWAN