

*Standing Desk
Owner's Manual*

SD9

Table of Contents

Welcome

Getting Started 3

Welcome

Warranty

Power

SD9 Desk Assembly 6

Assembly Instructions

SD9 Desk Operations 17

Specifications

Console Buttons

Congratulations on choosing the LifeSpan Workplace™ line of products. These products give you the opportunity to remain productive while taking care of yourself as you integrate movement with normally sedentary tasks.

The average American now spends eleven hours, five days a week, sitting, and burns one-hundred fewer calories each day than they did a few decades ago. Sitting for long periods slows your metabolism, reduces calories burned, and increases your risk for heart disease and diabetes.

Whether you plan on placing this product in a TV room, replace your desk at home or are adding another workspace in the office, LifeSpan Workplace™ products are a great way to add movement to an otherwise sedentary activity.

Before you assemble or operate your product, please read this manual thoroughly. Important information, including safety precautions, ongoing product maintenance, assembly instructions, and information on proper operation are included.

If you need to contact LifeSpan customer service, visit our website at www.LifeSpanFitness.com and select customer service. Complete the information requested and we will respond to your inquiry within one business day. In the United States and Canada you can also call 801-973-9993 and choose option 4.

Neither LifeSpan Fitness nor its representatives can accept responsibility for any damages or injury incurred as a result of information presented in this manual except under the terms of the product warranty.

Warranty

Your LifeSpan standing desk comes with the following limited warranty valid in North America and the United Kingdom. If you are outside of these areas contact your local distributor for warranty information or visit www.LifeSpanFitness.com.

Warranty	SD9
Frame	10 Years
Parts	2 Years
Labor	1 Years

LifeSpan warrants the equipment it manufactures is free from defects in materials and workmanship under normal use and services. The periods above are based on the date of purchase. During these periods, LifeSpan will replace defective parts. Free labor is included on all parts that are not normally assembled or replaced by the customer within the labor period.

If within the time frames specified above, any part fails to operate properly, login to our website at www.LifeSpanFitness.com, click on "Customer Service" and complete the form to request assistance or call 801-973-9993 option 4 for a Customer Service Agent (please note that certain kinds of service should only be performed by a qualified service technician).

LifeSpan reserves the right to make changes and improvements to our products without incurring any obligations to similarly alter any product purchased. In order to insure our product warranty and to ensure the safe and efficient operation of your LifeSpan product, only authorized parts can be used. The warranty is void if any parts other than those provided by LifeSpan are used.

Exclusions and Limitations:

- This warranty does not apply to any defects caused by negligence, misuse, improper assembly, or maintenance, accident, or "act of God."
- This warranty does not apply to discoloration of paints or plastics.
- LifeSpan shall not be responsible for incidental or consequential damages.
- This warranty is non-transferable form the original owner.

Registration

Should you need to process a warranty claim make sure you retain your purchase receipt to verify the date of purchase and register your LifeSpan product online. To complete the registration go to www.LifeSpanFitness.com and select "Product Registration".

About Your Standing Desk

Proper Grounding

LifeSpan equipment must be grounded. Improper connection of the equipment's grounding conductor can result in the risk of electric shock. Check with a qualified electrician or service person if you are in doubt as to whether the outlet is properly grounded. Do not modify the plug provided with the product or use a ground plug adapter to adapt to a non-grounded outlet. If the plug will not fit in the outlet, have the proper outlet installed by a qualified electrician.

Power Cord Options

This standing desk should only be used with the proper power cord and power outlet. Several power cord options (shown below) are available from LifeSpan. We do our best to include the correct power cord with the standing desk for your area. In the event that the correct power cord is not included in the packaging please contact your local distributor.

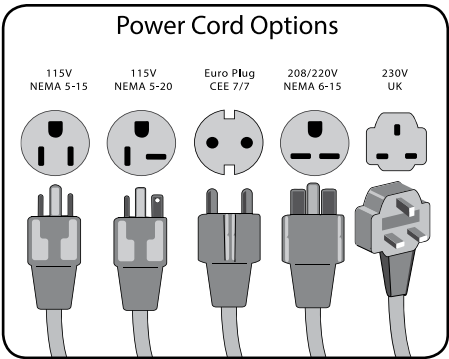
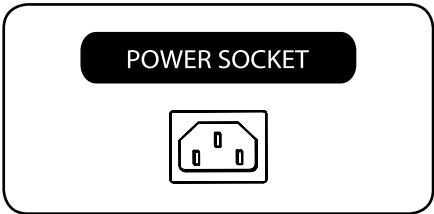

Do not use extension cords between the standing desk and power outlet.

SD9 Standing Desk: Assembly Instructions

At LifeSpan we strive to make our equipment easy to assemble and start using. Parts that can be pre-assembled are always assembled and tested on the product line.

Prior to starting the assembly process, take all the parts out of the box, remove plastic bags and lay everything out on the floor to become familiar with the components.

Since your desk is a heavy piece of equipment, it is recommended that you use two people during assembly and follow these assembly instructions to reduce any problems that may occur.

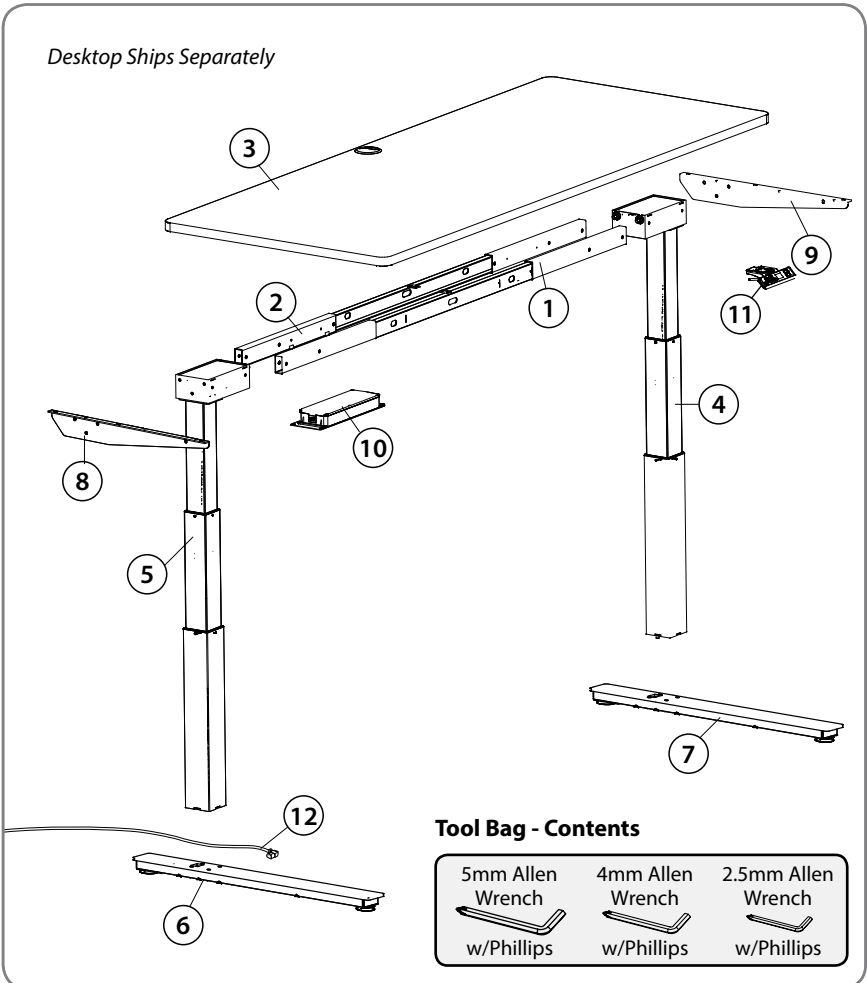

SD9 Standing Desk: Assembly Instructions

Hardware Included

Item#	Part Description
1	Front Reinforcement Frame
2	Back Reinforcement Frame
3	Desktop
4	Right Motorized Leg
5	Left Motorized Leg
6	Left Base Foot
7	Right Base Foot

Item#	Part Description
8	Left Desk Support Bracket
9	Right Desk Support Bracket
10	Electronics Control Box
11	Height Controller
12	Power Cord

Bag #	Item #	Qty.	Part Description
1	13	6	M8x12L Screws/Washers
2	14	8	M8x55L Bolts/Washers
3	15	6	M6x15L Screws/Washers
4	16	8	M8x35L Screws/Washers
4	17	6	M6x15L Screws/Washers
5	18	3	M4 x10L Screws/Washers
6	19	2	Phillips Screws
7	20	4	Cable Ties

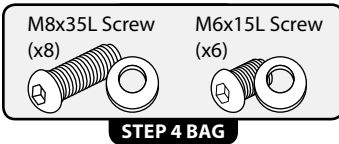

SD9 Standing Desk: Assembly Instructions

Step 1: Attach Right and Left Side Bracket

LOCATE BAG LABELED STEP 1

Contents: 6 each M8x12L screws with washers

- Add the *Left Desk Support Bracket(8)* to the *Left Motorized Leg(5)*. Each will have an "LLL" sticker attached for easy identification.
- Stand the leg on the motor side as shown in the illustration and align the bracket.
- Locate the screws for Step 1 and hand tighten the bracket to the leg. Then securely tighten with the included tool.
- Repeat for the *Right Desk Support Bracket(9)* and *Right Motorized Leg(4)*.

NOTE: Make sure that the power cable isn't set hard on the ground which could damage the wire.

NOTE: Do not tighten or loosen set screws. They have been pre-adjusted prior to shipping.

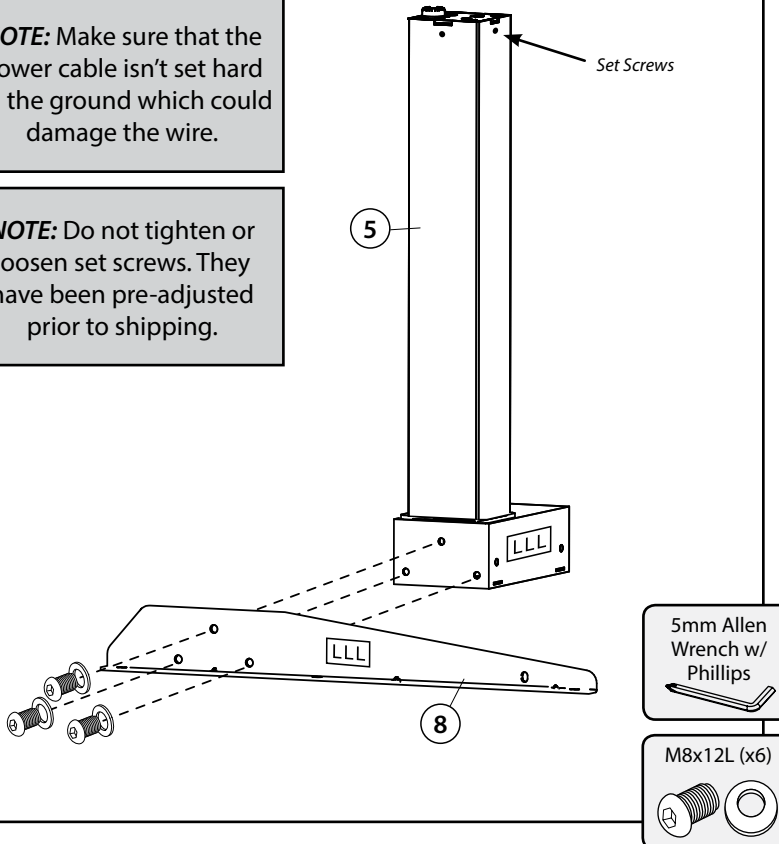

Step 2: Attach Base

**LOCATE BAG
LABELED STEP 2**

Contents: 8 each **M8x55L**
bolts with washers

- A. Align *Left Base Foot(6)* labelled 'LLL' with the *Left Motorized Leg (5)* and connect the wires.
- B. Push ALL extra wiring into the *Left Base Foot(6)*.

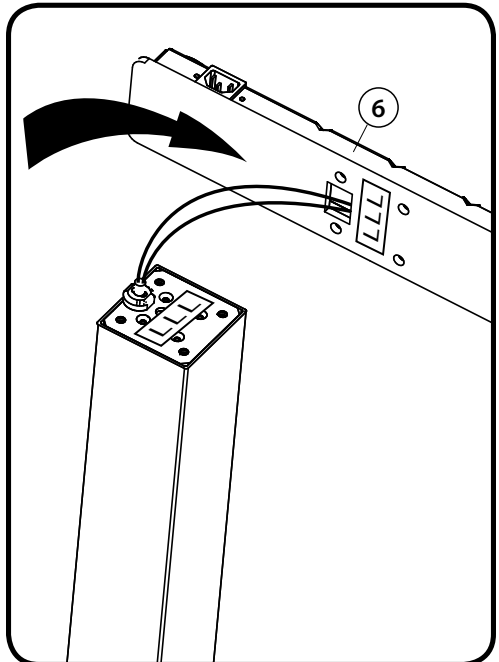
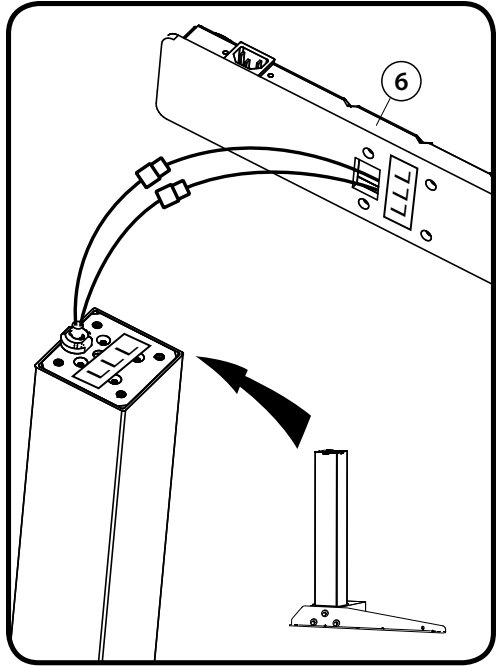

SD9 Standing Desk: Assembly Instructions

- C. Connect the *Left Base Foot(6)* to the *Left Motorized Leg(5)* with the four *M8x55L Bolts with Washers(14)*.
- D. Insert four *M8x55L Bolts(14)* being careful not to damage wires inside the *Left Base Foot(6)*.
- E. Hand tighten each of the four *bolts*.
- F. Tip the left post on its side.
- G. Repeat the same procedure on the right side.

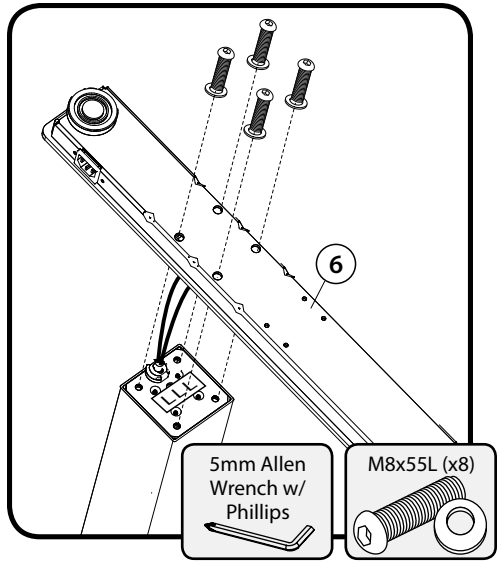

Step 3: Attach Desktop to Posts

LOCATE BAG LABELED STEP 3
Contents: 6 **M6x15L** Screws and Washers

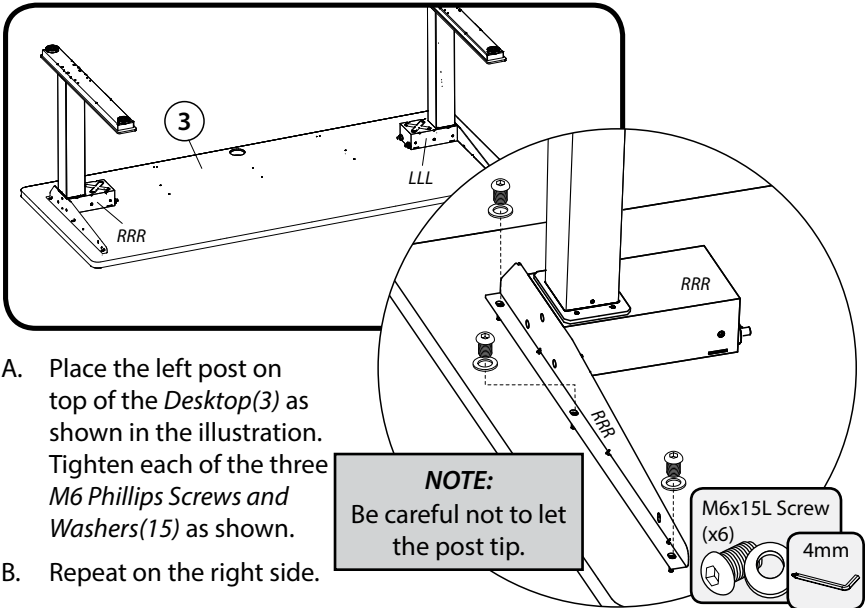

- A. Place the left post on top of the *Desktop(3)* as shown in the illustration. Tighten each of the three *M6 Phillips Screws and Washers(15)* as shown.
- B. Repeat on the right side.

Step 4: Attach Reinforcement Frame

LOCATE BAG LABELED STEP 4

Contents: 8 each **M8x35L** Bolts with Washers, 6 each **M6x15L** Screws.

- Locate the *Front Reinforcement Frame* labelled (1) and the *Back Reinforcement Frame* labeled (2). Place these frames on desktop with screw tabs down and facing each other as shown in figure below.
- Extend *Front and Back Reinforcement Frames*(1, 2) to align all mounting holes with *Desktop*(3) and *Motorized Legs*(4, 5).
- Loosely install the eight *M8x35L*(16) bolts through the *Reinforcement Frames* (1,2) and into the *Motorized Legs* (4,5).
- Tighten all eight *M8x35L*(16) bolts.
- Using the six *M6x15L Screws*(17) attach both reinforcement frames to the desktop as shown in the illustration.
- Tighten the pre-installed *Set Screws*(A) . Be careful not to overtighten as the tube will bend.

NOTE:

72" desktop shown for clarity of frame components. When mounting the frame to smaller desktop sizes, the front and back reinforcement frame pieces slide and compress into shorter lengths.

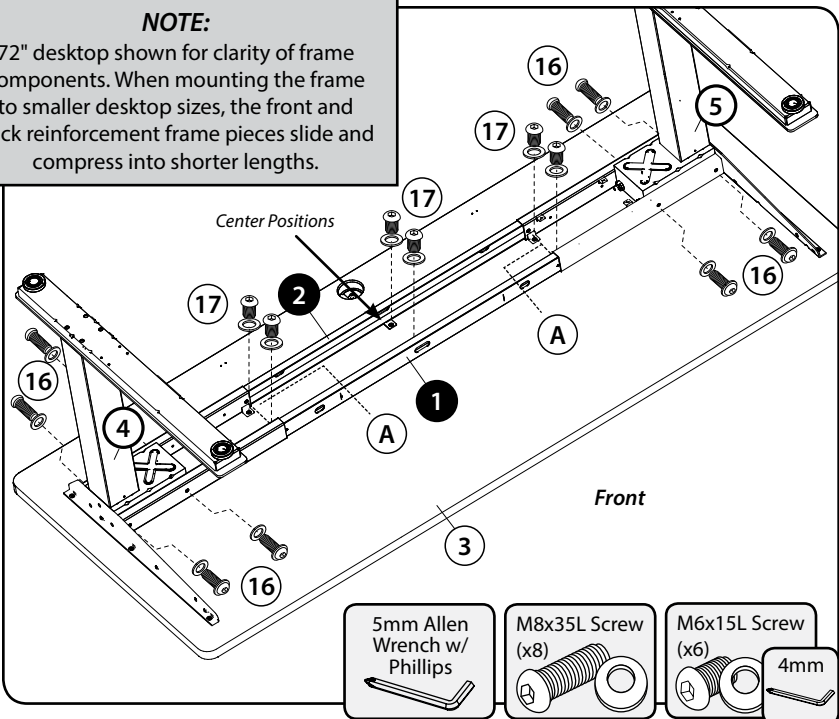

SD9 Standing Desk: Assembly Instructions

Step 5: Attach Electronics Controller Box

LOCATE BAG LABELED STEP 5
Contents: 3 each **M4x10L** Screws/Washers

- A. Guide the cable with the square connector(B) to the middle of the desk as shown.
- B. Connect the 2 pin power cable(C) to the *Electronics Controller Box*(10).
- C. Secure the *Electronics Controller Box*(10) in place with three *M4* screws(18).
- D. Attach square connector cables (B, D) to the left side of the *Electronics Controller Box*(10).

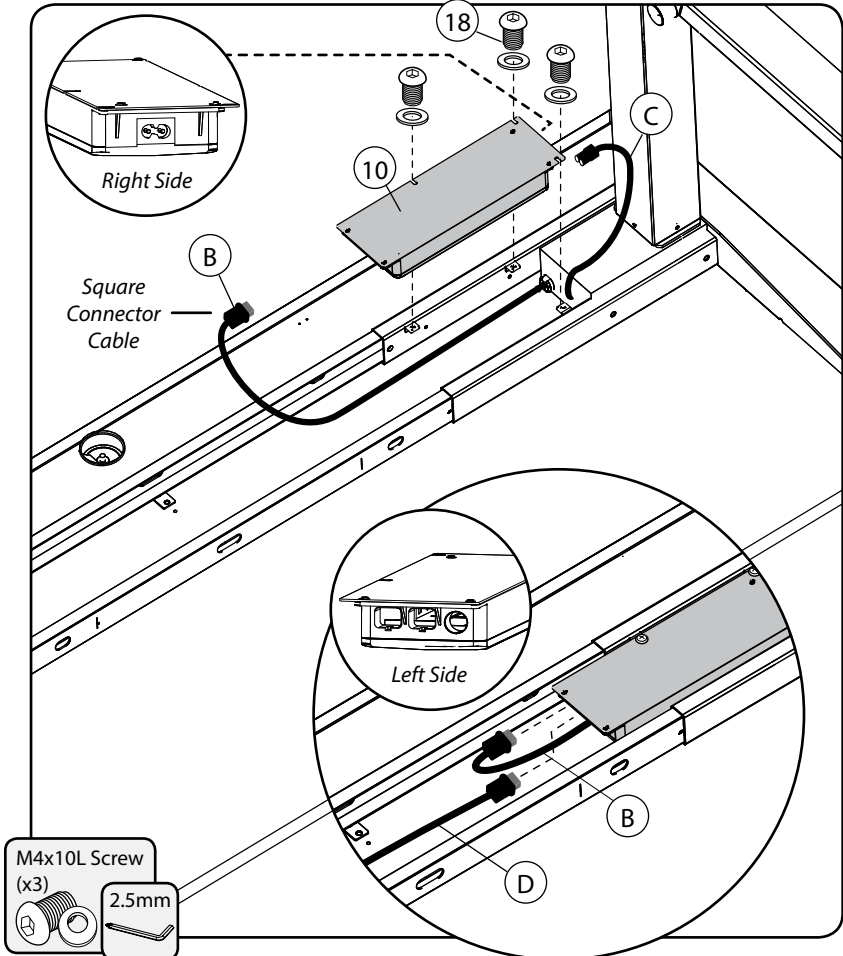

SD9 Standing Desk: Assembly Instructions

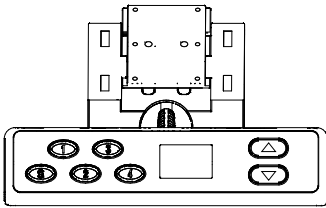

Step 6: Attach Height Controller

LOCATE BAG STEP 6

Contents: **Height Controller,**
Mounting Clip,
2 Phillips Screws

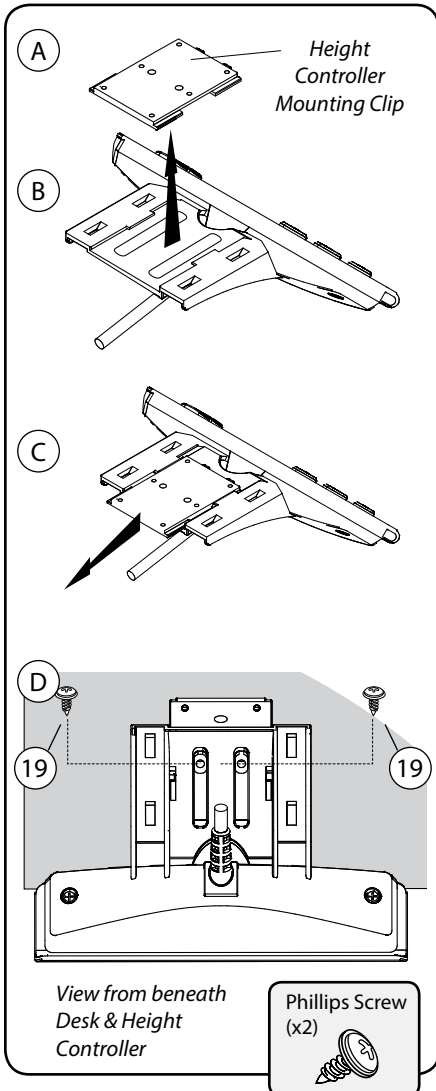

- Locate *Mounting Clip* and *Height Controller*(11).
- Connect *Mounting Clip* to *Height Controller* by lining up the locking tabs.
- Slide *Mounting clip* backward to locking position.
- Attach to right side of desktop with 2 *Phillip screws*(19) into pre-drilled holes.

SD9 Standing Desk: Assembly Instructions

Step 7: Attach Height Controller Cable

LOCATE BAG LABELED STEP 7

Contents: 4 **Cable Ties**

- A. Locate end of *Height Controller Cable (E)*, guide through hole in *Front Reinforcement Frame (1)* and connect to the *Electronics Control Box(10)*.
- B. Attach *Cable Ties(20)* to underside of desk in areas to best secure the *Height Controller Cable*.

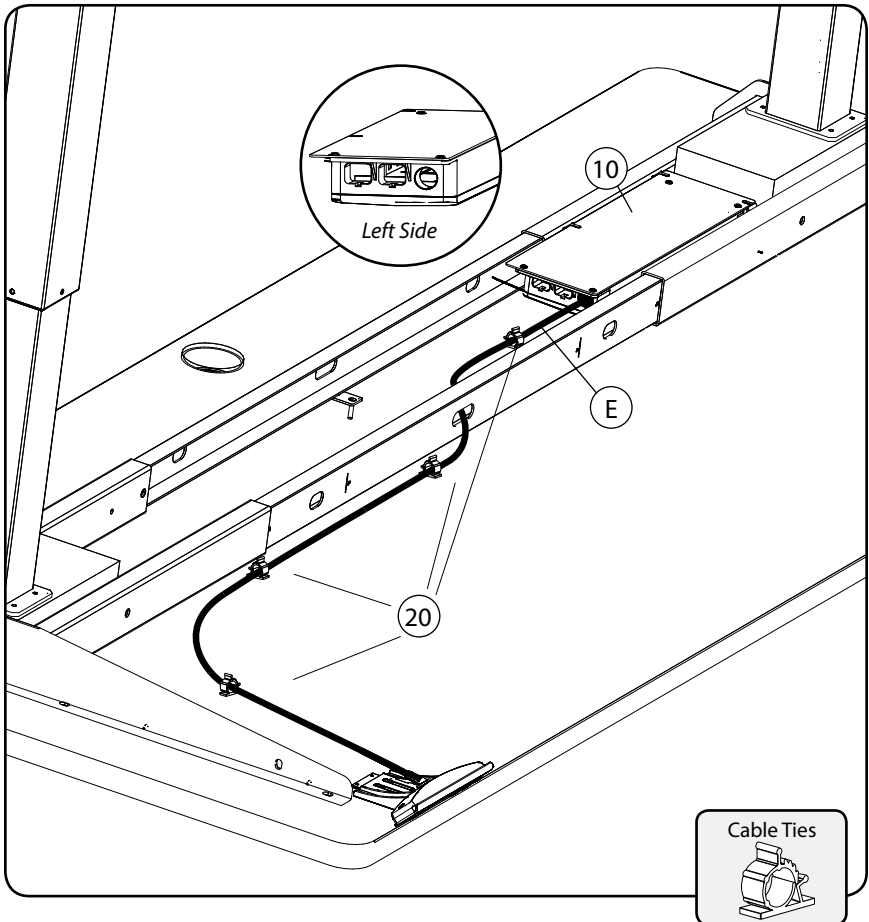

SD9 Standing Desk: Assembly Instructions

Step 8: Turn Upright and Attach Power

- A. Use 2 people to lift and turn upright; and position on floor where desired.
- B. Connect the *Power Cord (12)* from rear *Left Desk Foot* to an outlet.

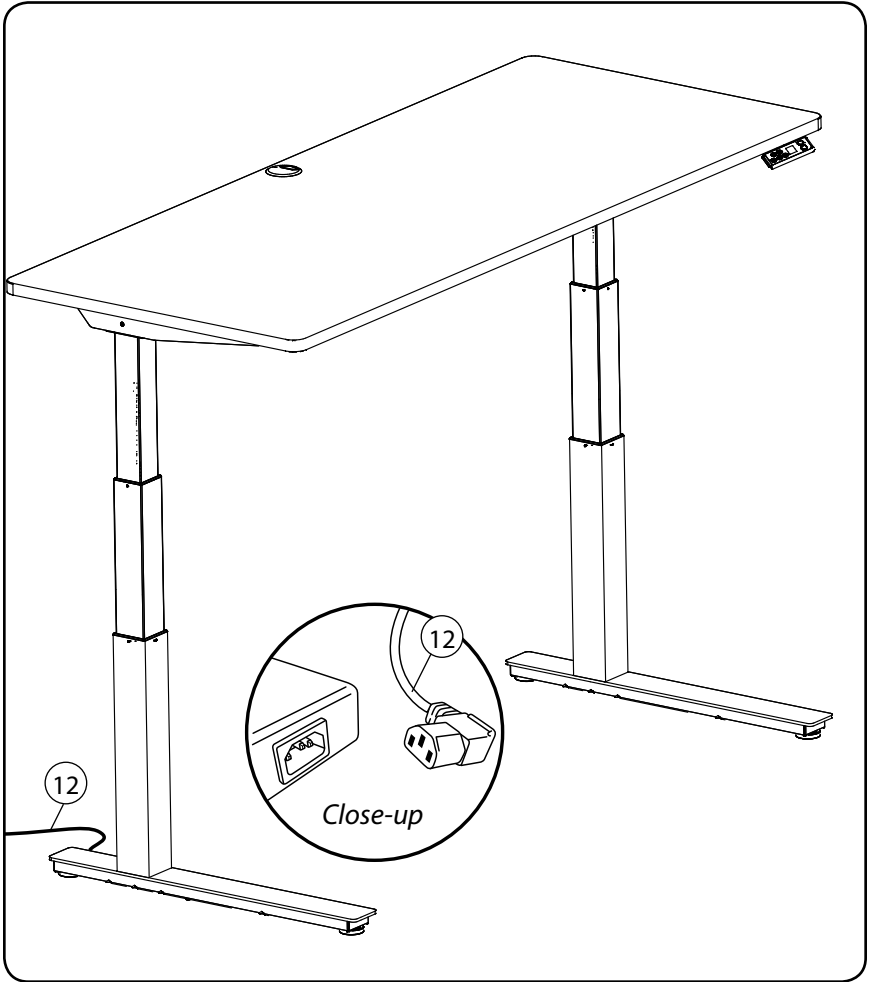

Standing Desk Operations

SD9 Standing Desk: Console Overview & Specifications

CONSOLE	SD9
Readouts	<i>Height Adjustment Levels</i>
Display	<i>White LED</i>
Buttons	<i>Height Adjustments, Memory Pre-sets</i>

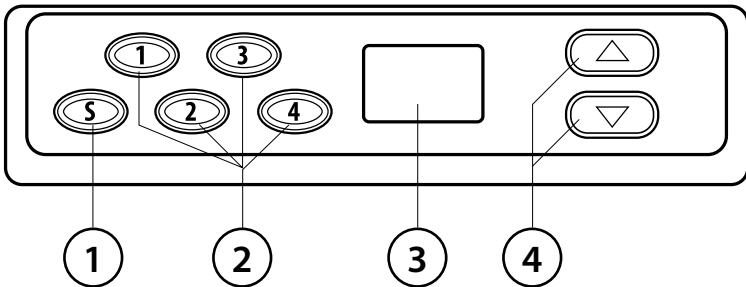

Console Buttons

1. **S**: Sets desk to desired height. Adjust desk height. Hold 'S' button down until display flashes. Push and hold 1,2,3 or 4 until number shows in display. This sets your desired height to that button.
2. **1-2-3-4**: Pre-set buttons remember 4 different heights.
3. **Display**: Shows height number setting from range of 079-099.
4. **▲ ▼**: Increases or decreases desk height.

SD9 Standing Desk: Console Overview & Specifications

Error Codes

Error Code	Description	Handling Steps
HOT	Overheat- System detects the action by not following the rated duty cycle and prevents it from overheating.	Stop operating until cool off.
E01	Overload- System detects excessive weight* arrangement by not following the rated capacity	Please remove some weight. Release button then press again can continue operation and show current height.
E16	Block- System detects a sudden resistance or pinch during moving.	Release button. Remove the block source then press button again can continue operation.

* Rated weight capacity is 220 lbs (100kg)

Calibration

1. Press and hold **S** and **UP** buttons. The **S** button needs to be pressed and held first then the **UP** button so both are being held at the same time. After a second or two the display will start flashing "Set". The buttons can be released. The desktop will go to the lowest position and then to the highest position and then back to the lowest. The console will then show the normal reading of the desktop.

SD9

Standing Desk

LifeSpan Fitness

P.O. Box 981316

Park City, Utah 84098-1316

Phone: 801-973-9993

www.LifeSpanFitness.com

Standing Desk Patent(s) Pending

Version 1.4