

LifeSpan™

RW1000

Owner's Manual

Please read all warnings and instructions prior to use



801-973-9993

www.LifeSpanfitness.com



P.O. Box 981316 • Park City, Utah 84098-1316



Innovative Fitness Solutions

Important Safety and Maintenance Instructions

- Always consult a physician before beginning this or any exercise program.
- If you experience chest pains, nausea, dizziness or shortness of breath, stop exercising immediately and consult your physician before continuing.
- Do not wear clothing that may catch under the roller wheels.
- Keep hands and fingers away from the seat roller wheels during use.
- Children: When in use, children should be at least 5 feet away.
- When folded, do not lean on or hang items on the Rower that may cause it to tip or fall over.
- Wipe down your rower with a soft cloth to keep clean as needed.

RW1000 Home Use Warranty

The LifeSpon RW1000 comes with the following warranty for residential use only:

| | |
|--------|----------|
| Parts: | 2 Year |
| Frame: | 10 Years |
| Labor: | 1 Year |

Max User Weight: 300 lbs.

PCE Health and Fitness Warrants that the equipment it manufacturers is free from defects in material and workmanship under normal use and service.

If within the time frame specified above, any part of the RW1000 fails to operate properly, contact your authorized PCE Health and Fitness Retailer to report the problem or contact PCE Health and Fitness at www.LifeSponfitness.com or (801) 973-9993.

PCE Health and Fitness reserves the right to make changes and improvements to our products without incurring any obligations to similarly alter any product purchased. In order to insure our product warranty and to ensure the safe and efficient operation of LifeSpon equipment, only authorized parts can be used. The product warranty is void if any parts, other than those provided by PCE Health and Fitness are used.

Exclusions and Limitations

- The Warranty does not apply to any defects caused by negligence, misuse, or improper assembly or maintenance.
- This Warranty does not apply to discoloration of paint or plastics.
- PCE Health and Fitness will not be responsible for incidental or consequential damages.
- This Warranty is non-transferable from the original owner.

Registration

You must register your LifeSpon product before a warranty claim can be processed and proof of purchase must be demonstrated at the time a claim is made. To complete your registration online, go to www.LifeSponfitness.com and fill out the online registration or fill out the warranty card provided with your Rower. Registration cards must be completed and sent to PCE Fitness within 30 days of purchase to activate the Product Warranty on your LifeSpon equipment.

PLEASE READ ALL WARNING LABELS PRIOR TO USE

Main Contents

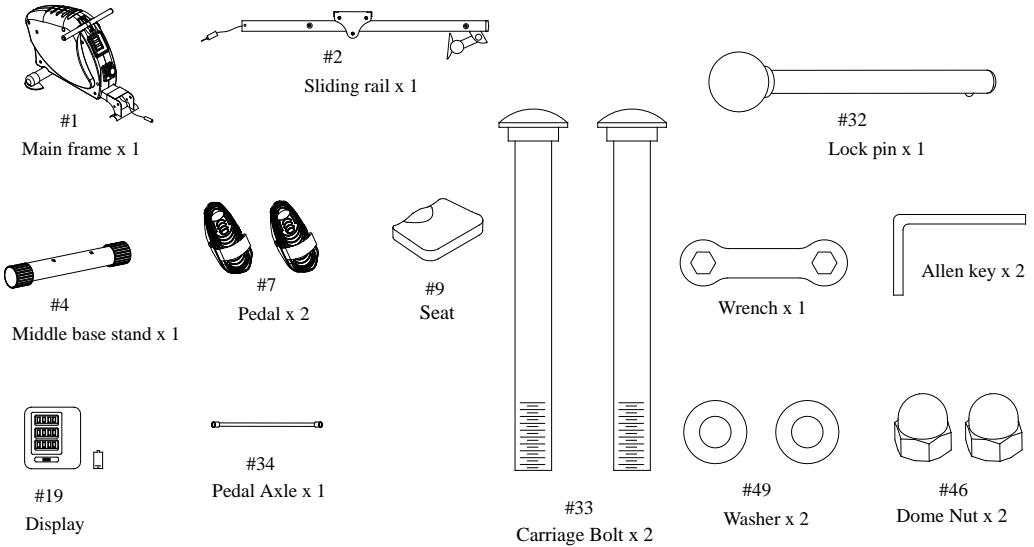

Complete Parts List

| Part# | Description | QTY | Part# | Description | QTY |
|-------|-----------------------------|-----|-------|--------------------------|-----|
| 1 | Main Frame | 1 | 26 | Screw for Rear Stand | 1 |
| 2 | Sliding Rail | 1 | 27 | Bolt, Front Pulley | 1 |
| 3 | Rear Support Stand | 1 | 28 | Bolt, Final Pulleys | 2 |
| 4 | Middle Base Stand | 1 | 29 | Bolts for attaching seat | 4 |
| 5 | Left Drive Cover | 1 | 30 | Bolt, Seat rollers/stops | 5 |
| 6 | Right Drive Cover | 1 | 31 | Sleeve, Seat Roller | 3 |
| 7 | Pedal | 2 | 32 | Lock Pin | 1 |
| 8 | Resistance System | 1 | 33 | Carriage Bolt | 2 |
| 9 | Seat | 1 | 34 | Pedal Axle | 1 |
| 10 | Seat Support | 1 | 35 | Bolts, Pedals | 2 |
| 11 | Rollers, Seat | 6 | 36 | Spacer Sleeve, Pedals | 2 |
| 12 | Pull handle | 1 | 37 | Harness, Reed Switch | 1 |
| 13 | End Plugs, Handle | 2 | 38 | Screw for cover | 7 |
| 14 | Foam grips | 2 | 39 | Screw for cover | 3 |
| 15 | Front Pulley | 1 | 40 | Screw for cover | 1 |
| 16 | Pulley, Final Lower | 1 | 41 | Screw for Tension Knob | 1 |
| 17 | Pulley, Final Upper | 1 | 42 | M8 Nylon Nut | 7 |
| 18 | Tension Knob | 1 | 43 | M10 Nylon Nut | 2 |
| 19 | Console | 1 | 44 | M1/2 Nylon Nut | 1 |
| 20 | Sensor wire / Reed switch | 1 | 45 | M8 Nut | 6 |
| 21 | End Plug for Sliding Rail | 1 | 46 | Dome Nut | 2 |
| 22 | Front/Rear Feet | 4 | 47 | Cap | 2 |
| 23 | Transport Wheel | 2 | 48 | M8 washer (big) | 3 |
| 24 | Front/Rear Seat Stop | 4 | 49 | M8 washer (small) | 2 |
| 25 | Plastic cover for wheel set | 1 | 50 | M10 washer | 4 |

Exploded View

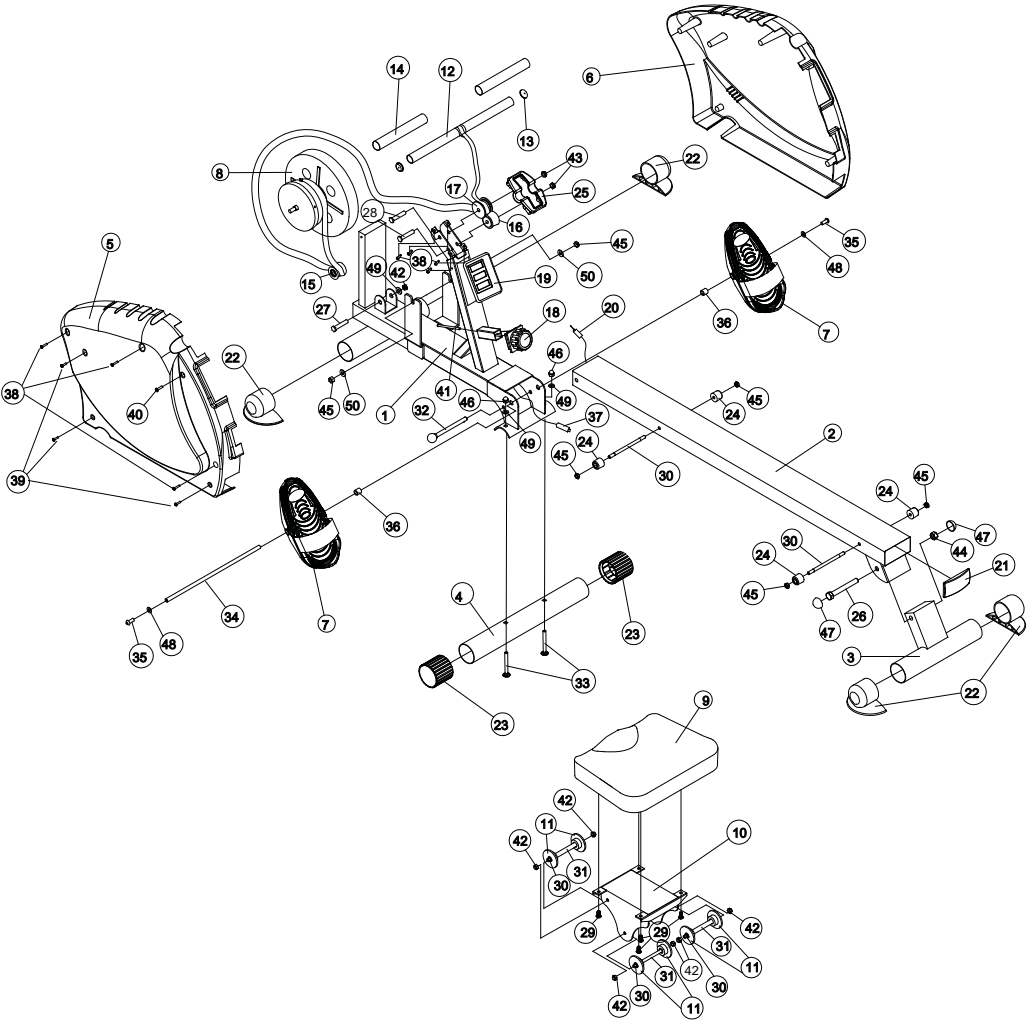

STEP 1:

ATTACH SEAT TO SLIDING RAIL

- a. Remove the 4 Allen Head Screws from the back of the seat.
- b. Place the seat over the seat bracket and tighten all four screws.

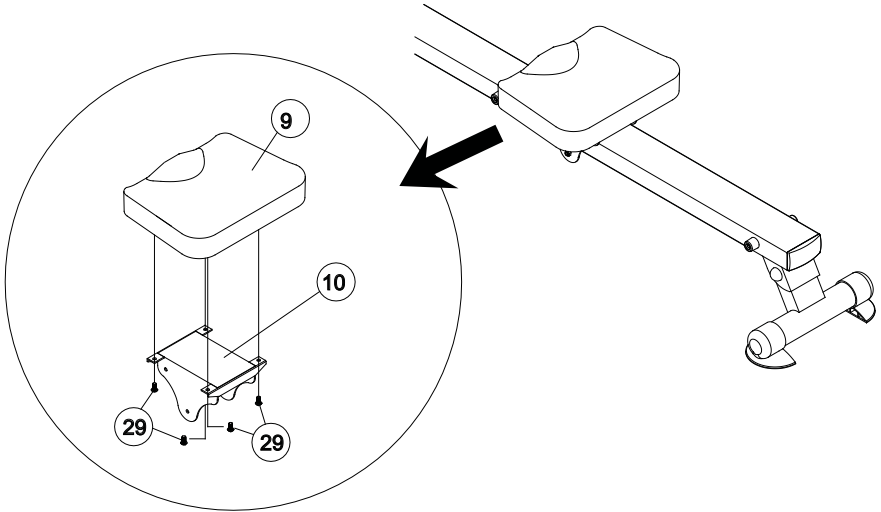

STEP 2:

ATTACH MIDDLE BASE TO MAIN FRAME

- a. Align the middle base under the main frame bracket.
- b. Insert the 2 carriage bolts from the bottom.
- c. Place a washer over the end of the carriage bolt and then tighten the dome nut securely.

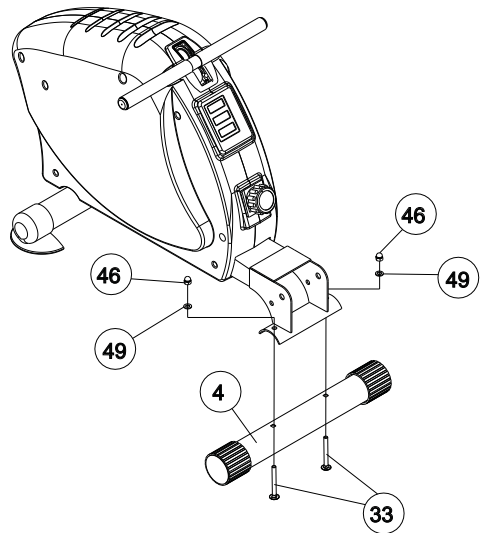

STEP 3:

ATTACH SEAT RAIL TO MAIN FRAME

- a. Line the seat rail directly behind the main frame and attach the wire connectors coming from the seat rail and main frame.

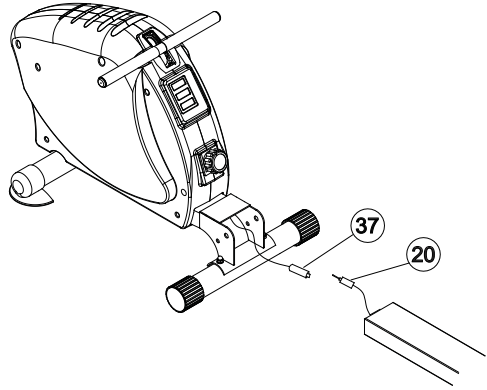

STEP 4:

PEDAL ASSEMBLY

- a. Remove the an Allen screw and washer from one end of the pedal axle.
- b. Push the end if the pedal axle through the **top** hole in the frame and the **only** hole in the rail, with a spacer on one side. Add the spacer and the pedal to the other side.
- c. Using an Allen Wrench on each end of the axle, tighten the Allen Screw with the washer that was removed earlier.
- d. Insert locking pin in the lower hole of the main frame while lifting the sliding rail up slightly near the pedal axle.

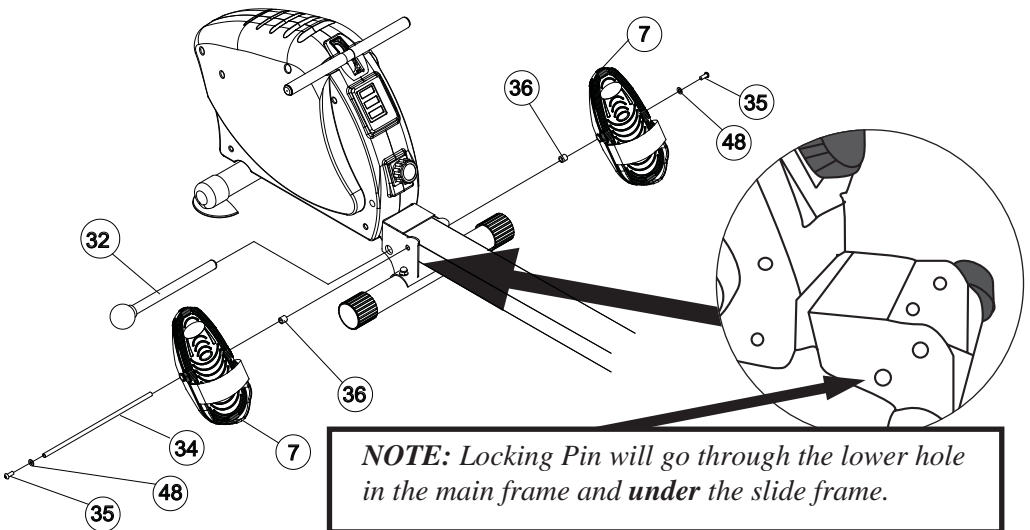

STEP 5:

INSERT DISPLAY CONSOLE

- a. Insert supplied AA battery into the back of display.
- b. Connect the cable inside the hole in the front of the main frame with the connector on the back of the console.

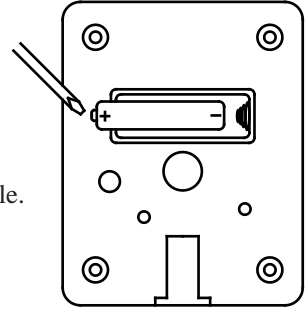
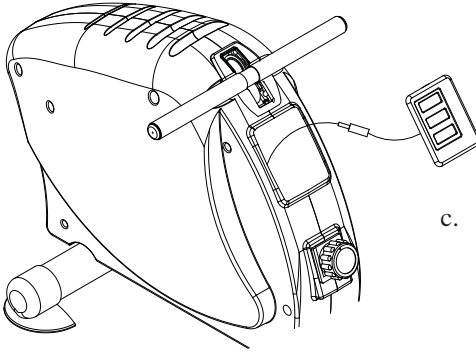

- c. Push the display console into the hole in the in the main frame until secure.

OPERATION

RESISTANCE - To increase the tension turn the adjustment knob to a higher number and to reduce the tension, turn the knob to a lower number.

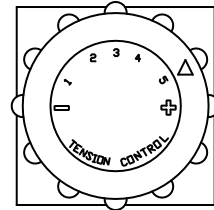

CONSOLE READOUTS - The console will automatically turn on when the Rower is in use. If there is no movement for over 4 minutes the console will automatically turn off.

PAGE: Press the “PAGE” button to scroll between functions on the console.

RESET: Press the “PAGE” button for 3 seconds to reset all values to zero.

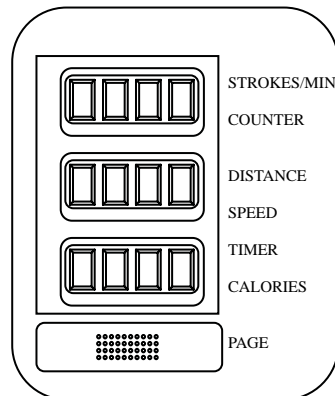

NOTE: If the display is illegible or only partially appears, remove the battery for 15 seconds and replace. Battery should be replaced once a year.

FOLDING

- a. To fold the rower, lift up the sliding rail near the pedal axle to relieve pressure from the locking pin.

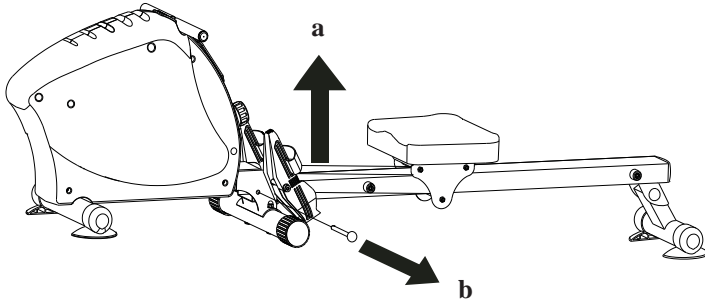

- b. Remove the locking pin.
- c. Lift the seat rail into the upright position and replace locking pin.

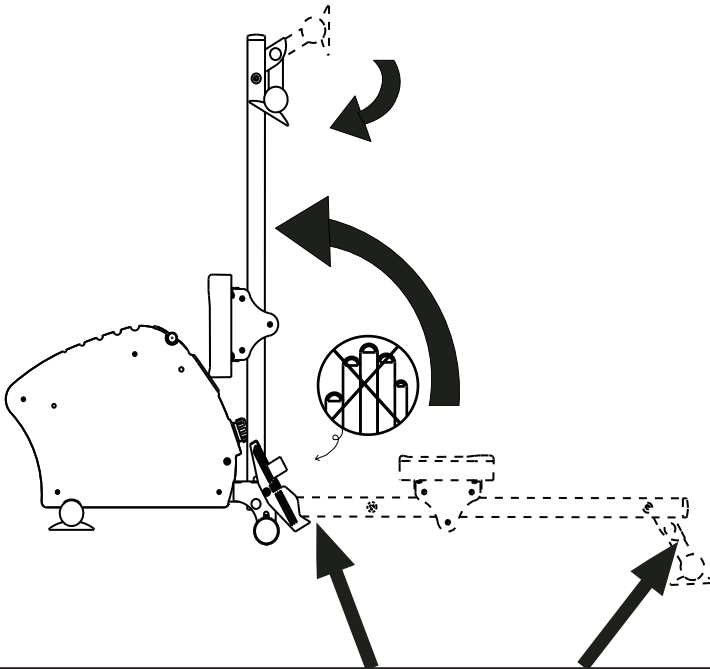

PLEASE READ ALL WARNING LABELS PRIOR TO USE