

# LifeSpan™

**PRO** series | treadmill

## **PRO5** treadmill

Owners Manual  
Version 1.0



# table of contents

	Page
Introduction . . . . .	1
Specifications. . . . .	2
Limited Home Use Warranty . . . . .	4
Important Safety Precautions . . . . .	5
Find a Certified Health Fitness Instructor . . . . .	6
Getting Fit . . . . .	7
Assembly Instructions . . . . .	9
Electronics Overview . . . . .	12
Exercise Programs . . . . .	13
Treadmill Operations . . . . .	15
Trouble Shooting . . . . .	18
Maintenance and Cleaning . . . . .	19

**Congratulations on the purchase of your LifeSpan PRO series treadmill.**  
To ensure safe and trouble free operation, we suggest that you read this Owners Manual and follow its recommendations.

## welcome to LifeSpan™

We all know that exercise is a key component to achieving the level of Health and Wellness that all of us desire. Regular activity prevents the development of numerous diseases, helps to reduce stress, leads to an improved self image, weight loss and increased energy levels.

The LifeSpan PRO series offer the discriminating consumer products that meet their exacting needs and with many of the models we include commercial warranties that cover institutional use up to 6 hours per day. The requirement for performance and durability is at the heart of each PRO series model. We start with a heavy gauge robotically welded steel frame, add top of the line components like 3" machine ground rollers, 1.0" reversible deck and 3 HP DC and AC motors. The result, are treadmills that deliver a smooth and consistent workout for every user that will last for years to come.

To make the PRO series easy to use we include our Intelli-Key™ blue button system that simply and easily steps each user through the program set-up process and for motivation we include speed programs, incline programs, heart rate control programs and distance programs to give our customers the programming variety they need to maintain their workout programs.

Please read this manual thoroughly before assembly and operation of your LifeSpan treadmill. It includes basic information on starting an exercise program, and safety tips that will assist you in reaching your goals for a healthy lifestyle.

To keep your treadmill in optimal condition, please pay attention to the maintenance and cleaning section of this manual and remember that some kinds of service should only be performed by a qualified service technician. If service is required, please contact your authorized PCE Health and Fitness Retailer. If a question or problem arises that cannot be answered by your retailer, contact us:

PCE Health and Fitness  
PO Box 981316  
Park City, Utah 84098 -1316  
Phone: (801) 973-9993  
Fax: (801) 973-9923  
[www.pcefitness.com](http://www.pcefitness.com)

Neither PCE Health and Fitness nor its representatives can accept responsibility for any damage or injury incurred as a result of information presented in the manual except under the terms of the product warranty.

# specifications



## ELECTRONICS AND PROGRAMMING

DISPLAY PANEL	Multi-Color Program Matrix 15 Character Alphanumeric LED 3 Single Panel LED Displays
READOUTS	Heart Rate, Incline, Speed, Distance, Time, Calories, Mile Track
PROGRAMS	Manual 5 Preset (Speed Change) 5 Preset (Incline Change) 5K and 10K Distance Target Heart Rate
HEART RATE	Chest Strap
SPEED/INCLINE CONTROL	Console Buttons Quick Speed & Incline Buttons

## MECHANICS AND PERFORMANCE

SPEED	.05 - 12 MPH
INCLINE LEVELS	0 - 15
BELT SIZE	63" * 22"
BELT TYPE	Multi-Ply with 2 ply no stretch and 2 ply PVC with anti-static layer
ROLLER SIZE	3.0" Tapered Roller with Oversized Bearings
MOTOR	3.0 Continuous Duty - AC
FRAME	Extra-Heavy Gauge Steel Welded Frame
SIDE RAILS	Aluminum Extrusion (Top and Side)
DECK	1.0" Reversible Deck with Variable Elastomer Suspension
LIFT MOTOR	1,000 lb Thrust
PRODUCT WEIGHT	308 lbs.
MAX. USER WEIGHT	400 lbs.
FLOOR SPACE	77" L * 36" W * 56"H

## WARRANTY

FRAME	10 Years - Residential 10 Years - Commercial
PARTS	2 Year - Residential 2 Year - Commercial
LABOR	1 Year - Residential/Commercial

## Power Requirement

This product should be used on a nominal 120-volt circuit with a grounding pole that looks like the outlet shown in the illustration below. Improper connection of the equipment grounding conductor can result in the risk of electric shock. Check with a qualified electrician or service person if you are in doubt as to whether the product is properly grounded. Do not modify the plug provided with the product. If it will not fit in the outlet, have the proper outlet installed by a qualified electrician.

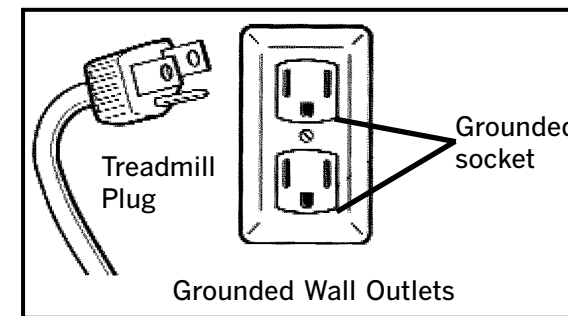

### For your Safety:

Never use extension cords, adapters, or surge protectors between the treadmill and the wall outlet.

Never remove or otherwise bypass with an adapter the electrical ground that is included.

### Notes:

GFI protected receptacles should not be used.

It is recommended that you use a 20 amp dedicated circuit.

This equipment generates, uses and can radiate radio frequency energy and may cause interference to radio communications. If interference does occur, the user will be required to correct the interference at his or her own expense.

## limited home use warranty

The LifeSpan PRO5 comes with the following warranty for home and institutional use. The institutional warranty covers up to 6 hours of use per day.

- Frame: 10 Years - Residential / Commercial
- Parts: 2 years - Residential / 2 years - Commercial
- Labor: 1 year - Residential / Commercial

PCE Health and Fitness warrants that the equipment it manufactures is free from defects in material and workmanship under normal use and service. The periods above are based on the date of purchase. During these periods, PCE Health and Fitness will repair or replace any defective part. Free labor is included for the first year.

If within the time frames specified above, any part of the LifeSpan PRO5 fails to operate properly contact your authorized PCE Health and Fitness retailer to report the problem. All labor shall be supplied by the authorized retailer that sold your product and the product must be located within that retailer's service area. If you are unable to reach the dealer that you purchased the product from, contact PCE Health and Fitness at our web site, [www.pcefitness.com](http://www.pcefitness.com) or at (801) 973-9993.

PCE Health and Fitness reserves the right to make changes and improvements in our products without incurring any obligations to similarly alter any product purchased. In order to insure our product warranty and to ensure the safe and efficient operation of your treadmill, only authorized parts can be used. The warranty is void if any parts other than those provided by PCE Health and Fitness are used.

### Exclusions and Limitations

- This warranty does not apply to any defects caused by negligence, misuse, improper assembly or maintenance, accident, or an "act of god".
- This warranty does not apply to discoloration of paint or plastics.
- PCE Health and Fitness shall not be responsible for incidental or consequential damages.
- This warranty is nontransferable from the original owner.

### Registration

You must register your LifeSpan product before a warranty claim can be processed. To complete your registration card online, go to [www.pcefitness.com](http://www.pcefitness.com) and fill out the registration card online or fill out the warranty card provided with your treadmill and mail it today. Registration Cards must be completed and sent to PCE Fitness within 30 days of purchase to activate the Product Warranty on your LifeSpan equipment. Product Warranties are not valid unless properly completed and sent to PCE Fitness within this 30 day period.

Note: Read ALL instructions before using your LifeSpan treadmill.

## important safety precautions

When using electrical equipment, basic precautions should always be followed, including:

- Never drop or insert any object into any opening.
- Never operate this treadmill if it has been damaged, if it is not working properly or if it has been exposed to water. Return the treadmill to a retailer for examination and repair.
- To reduce the risk of electric shock, unplug the treadmill from the wall outlet when not in use, before performing any maintenance, or before moving the treadmill.
- Do not use outdoors.
- Do not lean against or climb on the treadmill. Doing so may result in the treadmill tipping and falling and could result in serious personal injury.
- Do not hang or place items on the treadmill. Doing so could result in shifting the weight balance of the treadmill causing it to tip over or fall causing serious personal injury.
- Do not operate the treadmill with the side rails or dust covers removed.
- Keep the treadmill on a solid surface, with the sides and front a minimum of two feet from any walls and furniture. Make sure that the area behind the treadmill remains completely clear during use. A minimum of 4 feet of clearance behind the treadmill is required for safety reasons.
- Do not operate where aerosol spray products are being used or where oxygen is being administered.
- Never place the power cord under carpeting or place any object on top of the cord, which may pinch or damage it.
- Use this exercise product for its intended use as described in this Owners Manual. Do not use attachments that are not recommended by PCE Health and Fitness.
- Do not leave your treadmill running while not in use.

### Children and Pets

- Keep children off your treadmill at all times.
- When in use, young children and pets should be kept at least 10 feet away.

### Other Safety Tips

- To reduce the risk of burns, fire, electric shock, or injury, it is imperative to connect each product to a properly grounded electrical outlet.
- Do not reach into, or underneath, the treadmill or tip it on its side during operation.
- Always consult a physician before beginning this or any exercise program.
- If you experience chest pains, nausea, dizziness or shortness of breath, stop exercising immediately and consult your physician before continuing.
- Do not wear clothing or jewelry that might catch on any part of the treadmill.
- This treadmill is equipped with a safety key. If the key is removed from the display, the treadmill will immediately stop. Always clip the cord that is attached to the safety key to a part of your clothing so the key will be pulled from the display, stopping the treadmill, in case of an emergency.

## find a certified health fitness instructor

Everyone is unique. We all have different physical characteristics, medical backgrounds, and daily patterns that need to be considered to design the optimal workout and nutrition program. The Getting Fit section of your Owners Manual is designed to give you a brief overview that will be beneficial in starting or modifying your exercise program. We recommend however, that you consider using a certified fitness professional that is trained to tailor a fitness program specifically for you.

To support this, we have partnered with the American College of Sports Medicine (ACSM). The ACSM has certified Personal Trainers and Health Fitness Instructors that can assist you in getting started and in maintaining the right exercise program for you.

### **Below is a description of the Health/Fitness Instructor Qualifications:**

The ACSM Health/Fitness Instructor is a professional qualified to assess, design, and implement individual and group exercise and fitness programs for apparently healthy individuals and individuals with controlled disease. The Health/Fitness Instructor is skilled in evaluating health behaviors and risk factors, conducting fitness assessments, writing appropriate exercise prescriptions, and motivating individuals to modify negative health habits and maintain positive lifestyle behaviors for health promotion.

To find one of these professionals, just go to our web site at: [www.pcefitness.com](http://www.pcefitness.com) and click on the Find a Health Fitness Instructor tab. This service can help you locate an ACSM certified professional near you.

## getting fit

Cardiovascular endurance is the most important component of physical fitness. There are two types of cardiovascular training, these are interval training and steady state training.

Interval training varies the amount of effort required to workout. The LifeSpan PRO5 comes with 5 programs that vary speed automatically and 7 programs that vary incline. All of these programs vary the amount of effort required during the workout either through automatically adjusting the incline or the speed.

Steady state training keeps the workload constant. The Manual program on your LifeSpan treadmill allows you to manually control the speed and incline of your treadmill providing you with a constant workout that you completely control. The PRO5 also supports Heart Rate training where you can preset the treadmill to a target heart rate. The treadmill will then automatically adjust the speed and incline to maintain your target heart rate.

If you have a requirement to maintain a steady heart rate during your workout, the manual or Target Heart Rate Program is the best selection.

Regardless of your personal fitness goals and the program that you pursue, warming up and cooling down before and after you workout will help reduce the risk of injury and improve the effectiveness of your workout.

Warming up is important to bring your body from its normal level of activity to a state where it is ready to exercise by increasing the flow of blood to the muscle to raise the muscle temperature. This will increase the muscle elasticity and protect the joints. The warm up period also helps to mentally prepare you for your workout.

Warmups should be done at a low intensity level and last for at least five minutes.

Cooling down after your workout is required to gradually bring your cardiovascular system down to its normal level.

Follow your workout with at least 10 minutes of stretching. Focus on the major muscle groups of the lower extremity. When stretching, stretch the muscle until you feel gentle tension, hold it and wait for the tension to relax while the muscle elongates, stretch the muscle again until you feel gentle tension.

Do not bounce when you stretch, bouncing is not an effective approach to stretching and can lead to injury.

# assembly instructions

The three components of a successful cardiovascular exercise program are:

- Frequency
- Intensity
- Time

In terms of **frequency**, you should try and exercise at least three times per week. Preferably you should try to exercise every other day to give your body a days rest in-between workouts.

The **intensity** of each workout refers to how hard you feel your working and can be measured by your heart rate. Depending on your fitness goals, exercise between 55% and 90% of your maximum heart rate. A simple way of estimating your maximum heart rate is by subtracting your age from 220. As a general rule of thumb, if your fitness objective is to lose weight, you will want to keep your heart rate at between 60% and 75% of your maximum heart rate. If your objective is improved aerobic performance keep your heart rate between 75% and 85% of your maximum heart rate.

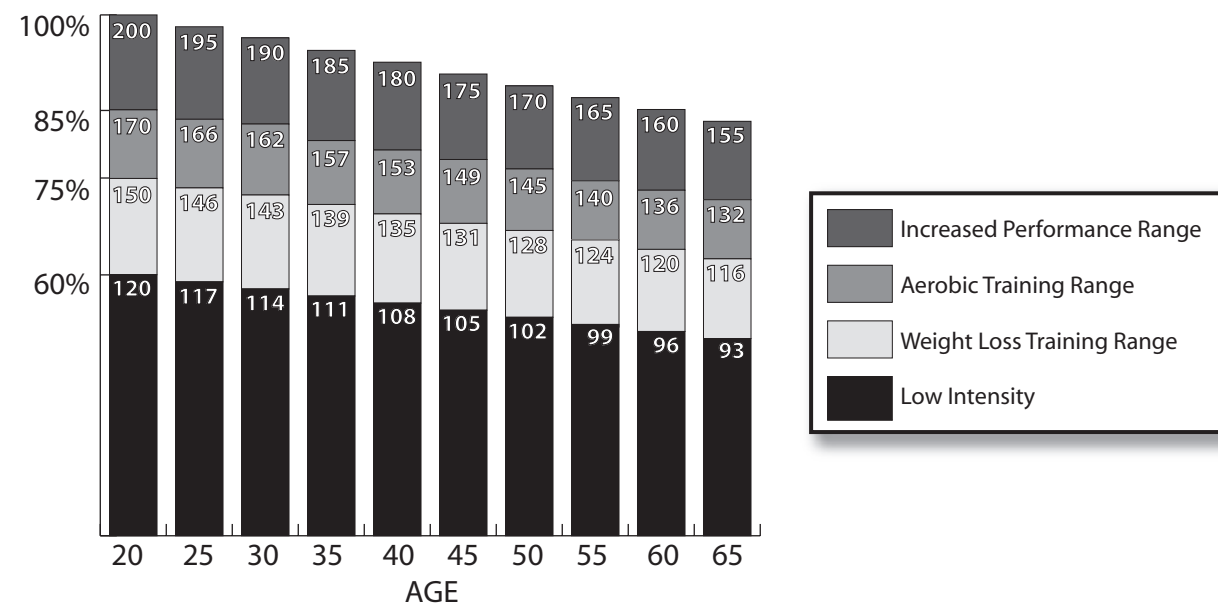

To achieve benefits from your workout, your workout **time** should be at least 20 minutes per session. If you are trying to lose weight focus on longer (45 - 60 minutes) less intense workouts, to improve your aerobic performance focus on shorter more intense workouts.

As a rule of thumb when your exercising, if your having trouble completing a sentence, you are working too hard. When exercising, you should be able to speak freely without gasping for air.

Since your treadmill is a heavy piece of equipment, we recommend that after taking off the top portion of the box, you slit the corners of the lower carton and fold down the sides. This will eliminate the need for you to pick up the treadmill over the sides of the box.

We also recommend that you use 2 people to assemble your treadmill, as some of the parts need to be held in place while the electrical connectors are pushed together.

Prior to starting the assembly process take all of the parts out of the box, remove all plastic bags, and lay them out of the floor to become familiar with the components. Make sure that you remove all parts packaged underneath the treadmill. You may need to slightly pick up the back of the treadmill to get better access to the parts on the bottom. You will notice that the treadmill is completely assembled except for the handlebars and the display.

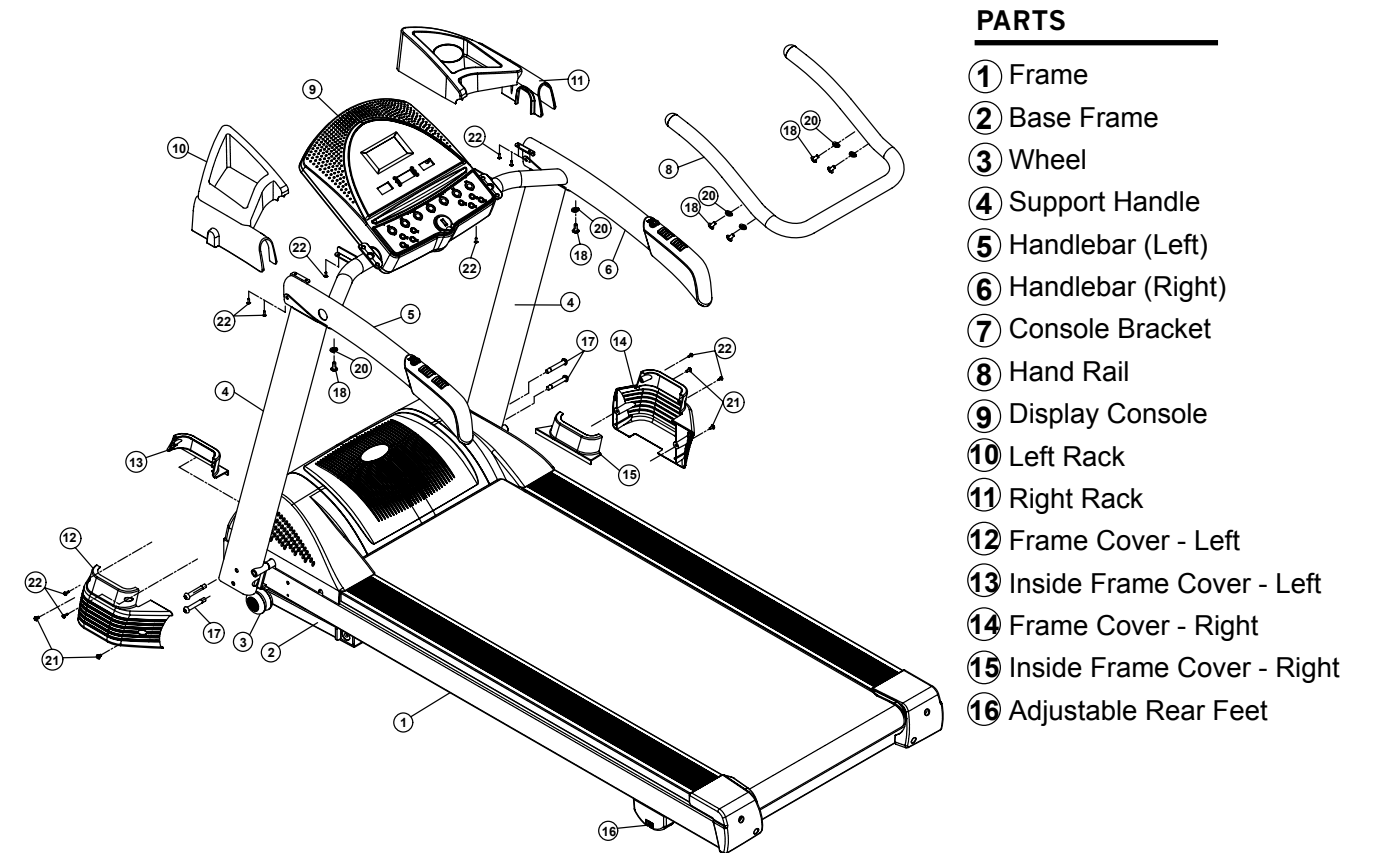

## HARDWARE-TOOLS

### Screws Already in Place on the Treadmill

M8*20L(6PCS)  18 screw	M8*15L(4PCS)  19 screw	M8(10PCS)  20 washer	W1/4**1/2"L(4PCS)  21 screw	M4*10L(10PCS)  22 screw
------------------------------	------------------------------	----------------------------	-----------------------------------	-------------------------------

### Tools and Screws in the Hardware Bag

M10*55L(4PCS)  17 screw	(1PCS)  23 T Handle Wrench	(1PCS)  24 Coupler	(1PCS)  25 PH2 Bit	(1PCS)  26 Hex 5mm Bit	(1PCS)  27 Hex 6mm Bit
-------------------------------	----------------------------------	--------------------------	--------------------------	------------------------------	------------------------------

### STEP 1: Handlebar Support Post Assembly

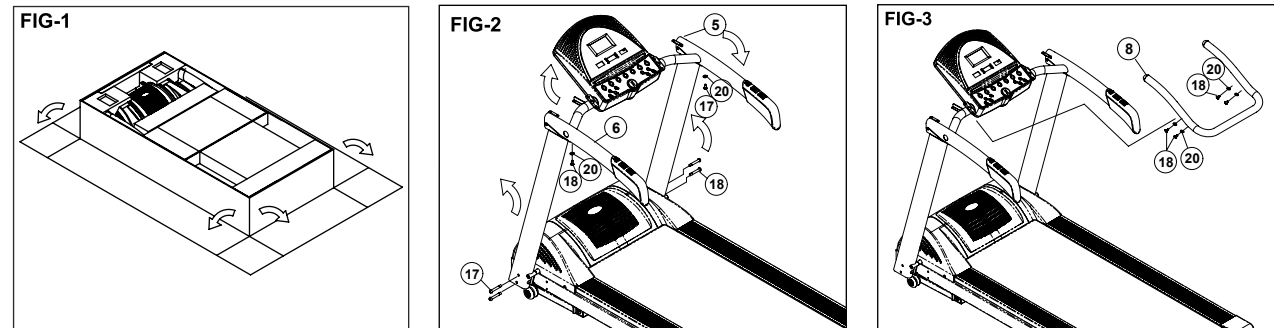

- A. Stand up the handlebar post (4) and attach the 4 dome head screws on the bottom of the handlebar posts (17). You may need to move the post forward and back slightly to properly align the holes. Make sure these 4 screws are securely tightened.
- B. Lift up the handlebars and remove screw (18) and washer (20) from the bottom of the left and right sides of the handlebars.
- C. Replace screws (18) with washers (20) underneath the handlebars securely to lock the handlebars in place.
- D. Assemble the “U” shaped safety bar by first removing screws (18) and washers (20) from the bottom of the hand rail. Then place the hand rail in position and secure screws (18) and washers (20) from underneath the console support post.

#### Notes:

1. Please hold the handlebars carefully in place during this step to prevent them from falling.
2. When raising the handlebars, be careful not to pinch the wiring harness.

### STEP 2: Base Cover Assembly

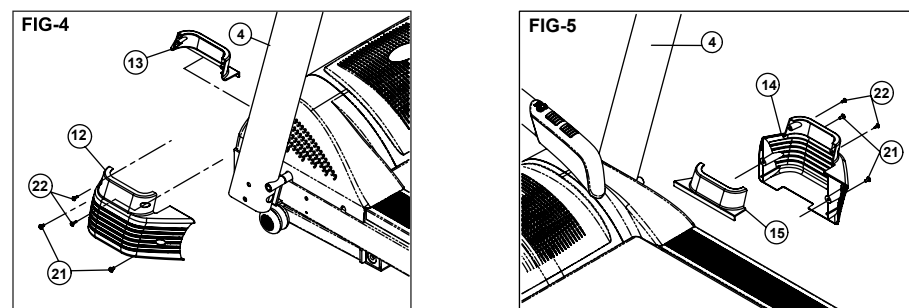

- A. On each side, remove the 2 screws (22) that hold the front and back of the base covers together.
- B. Fasten the outside portion of the base cover on the right and left sides of the treadmill using the Phillips head screws (21) that are pre-installed at the factory onto the treadmill frame.
- C. Attach the back of the covers using Phillips head screws (22)

### STEP 3: Handlebar and Console Assembly

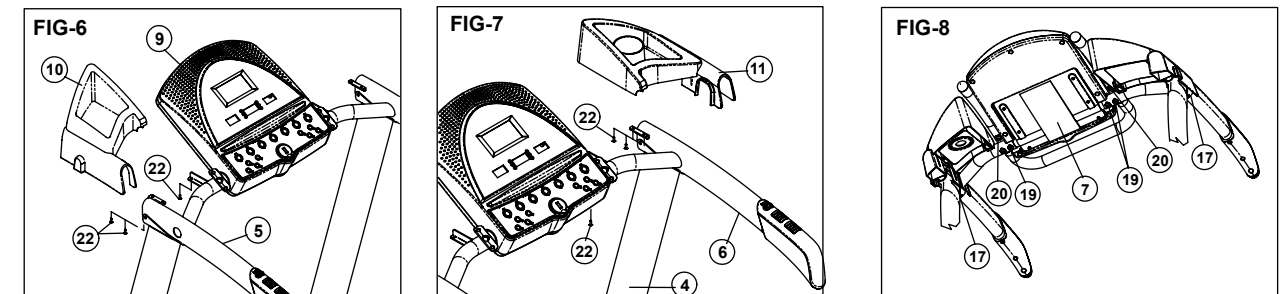

- A. Rotate the console to the proper position. Tighten the dome head Allen screws (22) on the back of the console support tube to lock the console in place.
- B. Mount the right and left storage trays.



# electronics overview

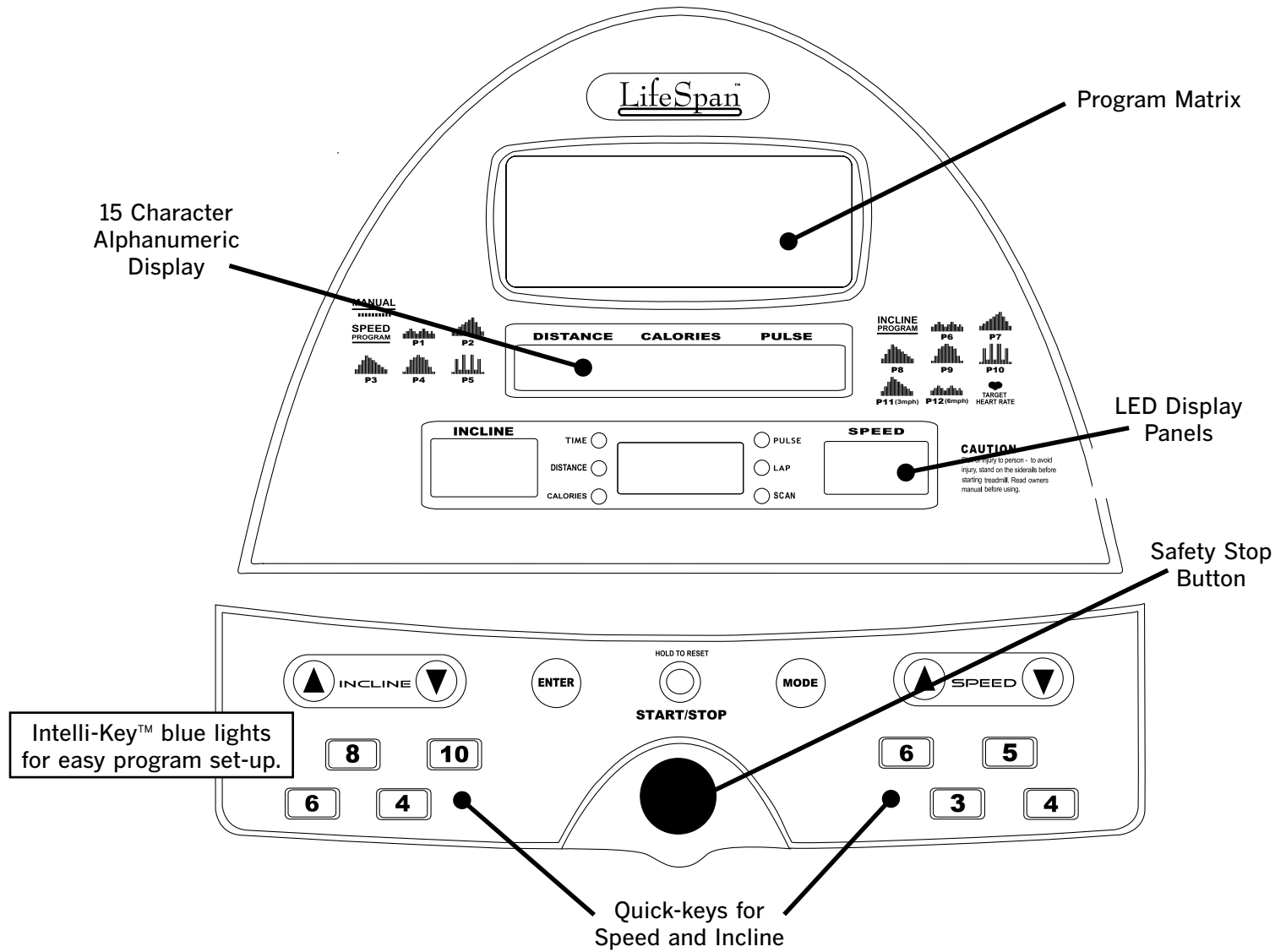

- Display console includes the **Intelli-Key™** blue lights. The flashing blue light shows you which button to press next to set-up and use the system programs.
- **Quick-key** buttons provide easy selection of a set speed or incline without scrolling.
- The **QuickStart** button lets you begin your workout in Manual mode without going through the set up process.
- **Heart Rate** readout supports using a chest strap.
- **Readouts** include Time, Distance, Calories, Pulse, Incline and Speed.
- The PRO5 comes with a center mounted **Red Safety Button** and can be used for emergency shut off. When you depress this button the treadmill belt will stop and reset itself. To begin the Safety Button needs to be twisted.

# exercise programs

## Preset Programs

The PRO5 comes with 5 Preset Speed Programs, these are programs P1 – P5, and 7 Preset Incline Programs, programs P6 – P12. Programs P1 – P10 are time based and completed when the preset time is obtained. Programs P11 (5 Kilometers or 3 Miles) and P12 (10 Kilometers or 5 Miles) are distance based with P11 being completed when your distance goes to 5 Kilometers and P12 is completed when you distance goes to 10 Kilometers.

All of the Programs, except the P11 and P12 distance programs are divided into 24 equal segments. As a result, if you set your workout time to 48 minutes each segment of your workout will last for 2 minutes, if your workout is for 24 minutes each segment will last for 1 minute.

All of the Programs have 3 levels that you can select during the set up process with the easiest program being level 1 and the most difficult being level 3.

**Speed Programs** - The profile for each speed program and the speed of each segment within each program is shown in the table below. Select the program that is best for your workout habits and be sure that you are able to exercise at the speeds associated with each program before you begin your workout.

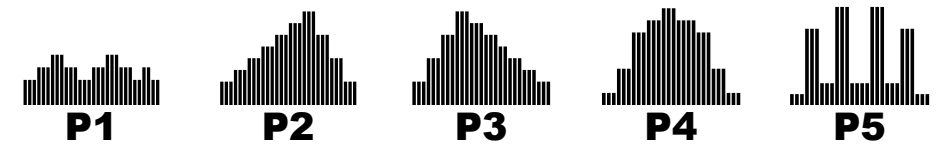

Speed Control Programs

	1	2	3	4	5	6	7	8	9	10	11	12	13	14	15	16	17	18	19	20	21	22	23	24
P1	1.2	1.2	1.8	1.8	2.5	2.5	2.5	1.8	1.8	1.8	1.2	1.2	1.2	1.8	1.8	1.8	2.5	2.5	2.5	1.8	1.8	1.8	1.2	1.2
P1	1.8	1.8	2.5	2.5	3.1	3.1	3.1	2.5	2.5	2.5	1.8	1.8	1.8	2.5	2.5	2.5	3.1	3.1	3.1	2.5	2.5	2.5	1.8	1.8
P1	2.5	2.5	3.1	3.1	3.7	3.7	3.7	3.1	3.1	3.1	2.5	2.5	2.5	3.1	3.1	3.1	3.7	3.7	3.1	3.1	3.1	2.5	2.5	2.5
P2	1.2	1.2	1.8	1.8	2.5	2.5	3.1	3.1	3.7	3.7	4.3	4.3	4.3	5.0	5.0	5.0	3.7	3.7	3.7	2.5	2.5	2.5	1.2	1.2
P2	1.8	1.8	2.5	2.5	3.1	3.1	3.7	3.7	4.3	4.3	5.0	5.0	5.0	5.6	5.6	5.6	4.3	4.3	4.3	3.1	3.1	3.1	1.8	1.8
P2	2.5	2.5	3.1	3.1	3.7	3.7	4.3	4.3	5.0	5.0	5.6	5.6	5.6	6.2	6.2	6.2	5.0	5.0	5.0	3.7	3.7	3.7	2.5	2.5
P3	1.2	1.2	2.5	2.5	2.5	3.7	3.7	3.7	5.0	5.0	5.0	4.3	4.3	4.3	3.7	3.7	3.1	3.1	2.5	2.5	1.8	1.8	1.2	1.2
P3	1.8	1.8	3.1	3.1	3.1	4.3	4.3	4.3	5.6	5.6	5.6	5.0	5.0	5.0	4.3	4.3	3.7	3.7	3.1	3.1	2.5	2.5	1.8	1.8
P3	2.5	2.5	3.7	3.7	3.7	5.0	5.0	5.0	6.2	6.2	6.2	5.6	5.6	5.6	5.0	5.0	4.3	4.3	3.7	3.7	3.1	3.1	2.5	2.5
P4	.6	.6	1.8	1.8	3.7	3.7	3.7	4.3	4.3	4.3	5.0	5.0	5.0	4.3	4.3	4.3	3.7	3.7	3.7	1.8	1.8	.6	.6	.6
P4	1.2	1.2	2.5	2.5	4.3	4.3	4.3	5.0	5.0	5.0	5.6	5.6	5.6	5.0	5.0	5.0	4.3	4.3	4.3	2.5	2.5	1.2	1.2	1.2
P4	1.8	1.8	3.1	3.1	5.0	5.0	5.0	5.6	5.6	6.2	6.2	6.2	6.2	5.6	5.6	5.6	5.0	5.0	5.0	3.1	3.1	1.8	1.8	1.8
P5	.6	.6	4.3	4.3	4.3	1.2	1.2	1.2	5.6	5.6	5.6	1.2	1.2	5.6	5.6	5.6	1.2	1.2	1.2	4.3	4.3	4.3	.6	.6
P5	1.2	1.2	5.0	5.0	5.0	1.2	1.2	1.2	6.2	6.2	6.2	1.8	1.8	6.2	6.2	6.2	1.2	1.2	1.2	5.0	5.0	5.0	1.2	1.2
P5	1.8	1.8	5.6	5.6	5.6	1.2	1.2	1.2	6.8	6.8	6.8	2.5	2.5	6.8	6.8	6.8	1.2	1.2	1.2	6.8	6.8	6.8	1.8	1.8

# treadmill operations

**Incline Programs** – for each Incline Program you select, the treadmill incline will adjust to the level of intensity of the program selected. Incline programs P6 through P10 are based on workout time and programs P11 and P12 are based on distance, 5K and 10K respectively.

When using the 5K and 10K programs each segment lasts for 20 seconds. When using programs P6 through P10 the workout time is divided into 24 equal segments.

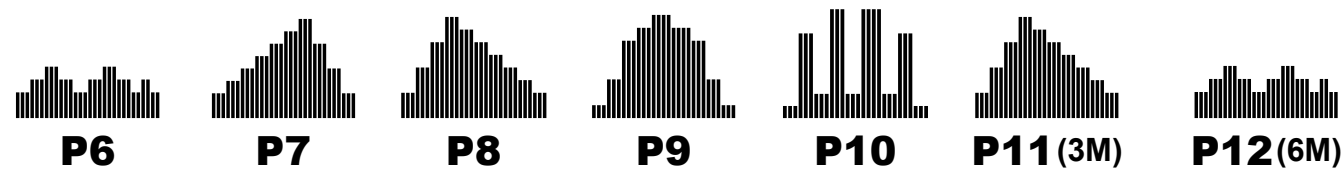

Incline Control Programs

	1	2	3	4	5	6	7	8	9	10	11	12	13	14	15	16	17	18	19	20	21	22	23	24
<b>P6</b>	2	2	3	3	4	4	4	3	3	3	2	2	2	3	3	3	4	4	4	3	3	3	2	2
<b>P6</b>	3	3	4	4	5	5	5	4	4	4	3	3	3	4	4	4	5	5	5	4	4	4	3	3
<b>P6</b>	4	4	5	5	6	6	6	5	5	5	4	4	4	5	5	5	6	6	6	5	5	5	4	4
<b>P7</b>	2	2	3	3	4	4	5	5	6	6	7	7	7	8	8	8	6	6	6	4	4	4	2	2
<b>P7</b>	3	3	4	4	5	5	6	6	7	7	8	8	8	9	9	9	7	7	7	5	5	5	3	3
<b>P7</b>	4	4	5	5	6	6	7	7	8	8	9	9	9	10	10	10	8	8	8	6	6	6	4	4
<b>P8</b>	2	2	4	4	4	6	6	6	8	8	8	7	7	7	6	6	5	5	4	4	3	3	2	2
<b>P8</b>	3	3	5	5	5	7	7	7	9	9	9	8	8	8	7	7	6	6	5	5	4	4	3	3
<b>P8</b>	4	4	6	6	6	8	8	8	10	10	10	9	9	9	8	8	7	7	6	6	5	5	4	4
<b>P9</b>	1	1	3	3	6	6	6	7	7	7	8	8	8	8	7	7	7	6	6	6	3	3	1	1
<b>P9</b>	2	2	4	4	7	7	7	8	8	8	9	9	9	9	8	8	8	7	7	7	4	4	2	2
<b>P9</b>	3	3	5	5	8	8	8	9	9	9	10	10	10	10	9	9	9	8	8	8	5	5	3	3
<b>P10</b>	1	1	7	7	7	2	2	2	9	9	9	2	2	9	9	9	2	2	2	7	7	7	1	1
<b>P10</b>	2	2	8	8	8	2	2	2	10	10	10	3	3	10	10	10	2	2	2	8	8	8	2	2
<b>P10</b>	3	3	9	9	9	2	2	2	11	11	11	4	4	11	11	11	2	2	2	9	9	9	3	3
<b>P11</b>	2	2	4	4	4	6	6	6	8	8	8	7	7	7	6	6	5	5	4	4	3	3	2	2
<b>P11</b>	3	3	5	5	5	7	7	7	9	9	9	8	8	8	7	7	6	6	5	5	4	4	3	3
<b>P11</b>	4	4	6	6	6	8	8	8	10	10	10	9	9	9	8	8	7	7	6	6	5	5	4	4
<b>P12</b>	2	2	3	3	4	4	4	3	3	3	2	2	2	3	3	3	4	4	4	3	3	3	2	2
<b>P12</b>	3	3	4	4	5	5	5	4	4	4	3	3	3	4	4	4	5	5	5	4	4	4	3	3
<b>P12</b>	4	4	5	5	6	6	6	5	5	5	4	4	4	5	5	5	6	6	6	5	5	5	4	4



**Target Heart Rate** – uses your heart rate to control the intensity of the workout. This program starts with a 3 minute warm-up and then starts to increase both the treadmill belt speed and incline to raise your heart rate up to the selected target.

During the set-up process, a maximum belt speed is selected. If this maximum speed is obtained during the program, only the incline level will be adjusted until you reach your target heart rate.

Before starting your treadmill the following actions will need to be properly completed:

1. Be certain that your treadmill sits stable on the floor. It is also recommended that you locate your treadmill in a pleasant area that gives you something to look at while working out, such as a window or television. Maintaining an exercise program with a treadmill located in a poorly lit basement room is more difficult than when your treadmill is located in an active and pleasant location.
2. Make sure that your treadmill is plugged into a properly grounded outlet as described in the grounding section of this document.
3. Turn the On/Off switch, which is located in the front of your treadmill, to the "On" position.
4. Make sure the Safety Button is in the operating position. If the safety button is pushed in, the program matrix will say "Key" and the safety button will need to be twisted and released before the console is able to function.

## QuickStart

1. QuickStart - The quickest and easiest way to start your treadmill is to push the QuickStart button. This will cause the display to count down for 3 seconds and then begin in the "Manual Program" at .5 Miles Per Hour.
2. Speed Adjustment – can be increased and decreased in 2 different ways:
  - Display Console –  Each time you depress the "Fast" button on the display console the speed will increase by .1 Miles Per Hour.
  - Quick Buttons – the display console includes buttons that immediately set the speed to 3, 4, 5, and 6 MPH without having to scroll through the speeds.
3. Incline – like the speed settings, incline can be adjusted 2 different ways:
  - Display Console –  Each time you depress the "Up" or "Down" button on the display console the incline will increase or decrease by 1.
  - Quick Buttons – the display console includes buttons that immediately set the incline to 4, 6, 8, and 10 without having to scroll through the incline levels.
4. Display Readouts - the console has a 15 character Alphanumeric display and 3 separate LED displays so that all readout functions can be viewed at the same time without any scanning or scrolling. These readouts include Time, Distance, Calories, Pulse, Incline and Speed.

## Programs Setup and Selection – P1 - P12

The PRO5 comes with the LifeSpan Intelli-Key™ button system that simply and easily steps you through the program setup process.

1. **Select Program:** With the Red Safety Button in the operating position the “up” and “down” speed arrows flash. This shows you that these buttons need to be pressed to scroll through the various program options. While scrolling through the program options, the program profiles will appear in the program matrix and the program number will appear in the center LED display panel. Use the arrows to scroll to the program you would like to use and then press the “Enter” button.
2. **Select Level:** Chose the workout level by using the “up” and “down” incline buttons and then press “Enter”. The Intelli-Key system will once again make the buttons that you need to press flash.
3. **Set Time:** Now chose how long you want to work out by pressing on either set of “up” and “down” arrows. Once complete press the “Start” button.

*Note: Programs P11(5KM) and P12 (10KM) are based on distance and not time. After selecting the Level, press Start to begin the workout.*

## Target Heart Rate Program Setup

1. **Select Program:** Press the “up” and “down” speed arrows to scroll to the Heart Rate program and press “Enter”.
2. **Set Time:** Use either set of “up” and “down” arrows. To scroll to your desired work out time. Then press the “Enter” button.
3. **Select Age:** Use either set of “up” and “down” arrows to select the users age. Then press the “Enter” button.
4. **Set Target Heart Rate:** Use either set of “up” and “down” arrows to set the target heart rate in Beats Per Minute (BPM). After a 2 minute warm up period, the program will automatically adjust the speed and incline to maintain this target heart rate.
5. **Set Max. Speed:** Use the “up” and “down” speed arrows to set the maximum speed that you want the treadmill to run to get you to your target heart rate. After this Max. Speed the treadmill will only adjust the incline to get to your target heart rate.

*Note: Using your chest strap is the preferred method when using the target heart rate program. Adjust the transmitter portion of your chest strap to the left side of your chest, right over the heart. It may take a few minutes for your body to moisten the chest strap to improve the contact between the transmitter and your skin. If the chest strap is having difficulty picking up your heart beat, warm up for several minutes or use Aloe Vera on your skin where the chest strap is picking up your heart rate.*

## Pause Function

Pause the treadmill at any time during operation by pressing the “Start/Stop” button once. To resume operations, press the “Start” button.

## At The End Of Every Exercise Session Always...

1. Use the master power switch to turn the treadmill off. The master power switch is located at the front of the treadmill.
2. Always position and store the electrical cord where it is clear from all pathways.
3. Unplug the electrical cord from the electrical outlet. This is especially important if you are not going to use your treadmill for extended periods.
4. Wipe all treadmill surfaces with a dry cloth or towel especially perspiration on the handlebars, control panel, running belt or other treadmill components.

## troubleshooting

The treadmill is designed and manufactured to be reliable and easy to use. However, if you have a problem, these troubleshooting steps may help you find the cause.

**Problem:** The console lights do not light up.

**Solution:** Check to make sure the treadmill is properly plugged in, the On/Off switch is turned to the "On" position and the safety button is not pushed in.

**Problem:** The belt does not stay in the center of the treadmill when in use.

**Solution:** First check to make sure that the treadmill is level, then refer to the instructions in this manual on how to tension and adjust the belt.

**Problem:** The treadmill motor seems strained or the fuse becomes blown.

**Solution:** The lubricating silicone that is applied to the deck and belt is wearing down and the belt needs to be lubricated with 100% silicone available from PCE Fitness.

**Problem:** The treadmill belt slips during use.

**Solution:** The belt may need to be tensioned after a period of use. Refer to the Belt Tensioning and Adjustment Section of this manual.

**Problem:** After assembly, the Heart Rate does not show on your display.

**Solution:** Check the wiring connectors in the handlebars and display, that were pushed together during assembly and make sure that they are connected properly and that the wires were not damaged.

## maintenance and cleaning

### Belt Tensioning

If the belt begins to slip during use, it will need to be tensioned. Your treadmill is equipped with tension bolts that are accessible from the back of the treadmill. Before tensioning the belt, start the treadmill and set the speed to 3 MPH. Using a 6 mm Allen Wrench, included in your hardware bag, turn the right and left tension bolts 1/2 turn, alternating back and forth until the belt slipping stops. After you adjust each side 1/2 turn, test to see if the slipping is eliminated. If the belt still slips repeat this step and test again.

If you turn one side more than the other, the belt will start to drift to the side of the treadmill and need to be aligned.



### Aligning the Running Belt

Ensure the running belt is centered on your treadmill at all times. Running style and a un-level surface are two instances that may cause the belt to drift off center. Minor adjustments to the two bolts at the rear of the treadmill are necessary when the belt has drifted off center.

1. Press "START" to begin running belt, then increase the treadmill's speed to 3MPH.
2. Stand at the rear of the treadmill to determine which direction the belt is drifting.
3. If the belt drifts to the left, turn the left adjustment bolt one-quarter turn clockwise and the right adjustment bolt one-quarter turn counter-clockwise. (See FIG.C)
4. If the belt drifts to the right, turn the left adjustment bolt one-quarter turn counter-clockwise and the right adjustment bolt one-quarter turn clockwise. (See FIG.D)
5. Observe the tracking of the belt for about two minutes. Repeat step 3, 4 and 5 as needed.

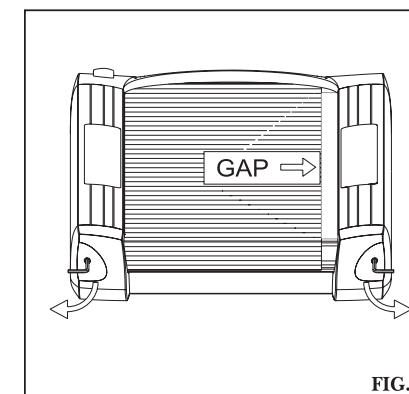

FIG.C

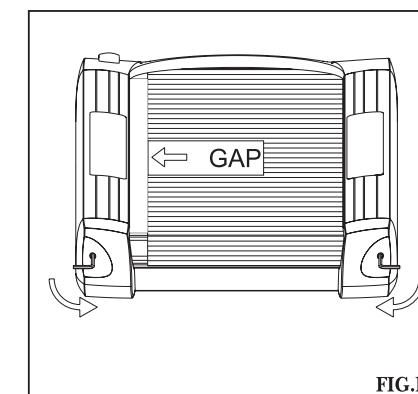

FIG.D

## **Belt Lubrication**

Periodically lubricating the running belt on your PRO5 treadmill is the most important maintenance procedure. Without proper belt maintenance and lubrication the friction between the belt and running deck will increase causing additional wear and tear on moving parts and electronics. Replacement of the belt, deck, drive motor and motor controller board may not be covered under your product warranty plan if regular maintenance is not performed on your treadmill.

It is recommended that you lubricate the belt every 200 hours of use or every 3 months, whichever comes first.

To lubricate the belt, use only 100% silicone. We recommend highly that you do not use compressed silicone since it contains additives and petroleum distillates that may be harmful to you and damage your treadmill belt. You can order 100% silicone from PCE Fitness directly by going to our web site at [www.pcefitness.com](http://www.pcefitness.com) or calling us at (801) 973-9993.

To lubricate your running belt complete the following steps:

1. Loosen the running belt by turning the two belt tension screws counter clockwise 10 complete rotations. This will require the 6 MM allen wrench provided in your toolkit. Be careful to count 10 full rotation on each side. This will make it easier to re-tension the belt to its original setting after silicone has been applied.
2. Lift up the running belt and apply approximately 1 ounce of silicone lubricant evenly to the top of the running deck. You will need to spray the silicone from both sides of the running deck.
3. Re-tighten the running belt by tightening each tension screw 10 complete turns clockwise. Be careful not to over tension.

## **Cleaning**

After use, wipe down your treadmill with a soft cloth. On a regular basis, you will also want to clean the treadmill using a mild detergent to remove all dirt and salt from the belt, painted parts and the display.

Avoid getting dirt and other materials on the belt as these materials can work their way under the belt and damage your treadmill or cause components to wear prematurely.

Periodically cleaning under the motor hood may be required. This is especially true if you have cats or dogs as hair can collect inside the motor cover which reduces air circulation, causing heat build up which can damage components. Excessive hair and fiber build up can also be dangerous and even cause fires.

It is recommended that you remove the hood once every 6 months of normal use to inspect hair and fiber build up and vacuum if necessary. Make sure that you turn off the on/off power switch and unplug your treadmill prior to removing the hood.

To remove the hood, loosen the 4 Phillips head screws that secure the hood. Two of these screws are located on the front of the hood and one is located on each side. Once the screws are loosened the hood can easily be lifted up.

If vacuuming is required, be careful not to hit or damage electrical parts.

Once complete, replace the hood and tighten each screw.

*Danger: Always unplug your treadmill from the wall outlet prior to removing the motor hood.*





**801-973-9993**

**[www.pcefitness.com](http://www.pcefitness.com)**

P.O. Box 981316  
Park City, Utah 84098-1316