



**CYCLE
BOXER**

Total Immersion Fitness™

Owner's Manual

For safe use and product knowledge, please completely
read this Product Owner's Manual.

Congratulations on Purchasing Your Cycle Boxer!

At Cycle Boxer we take pride in the quality, safety, and reliability of our products as well as the professionalism of our sales support and customer service teams, making it our number one priority that you have an exceptional experience using our products. This unique fitness machine combines cycling and boxing, with a variety of preset and customizable programs for a workout.

In support of this quality focus we pre-assemble parts on the manufacturing line whenever possible to reduce the number of steps and complexity of your assembly. We independently certify our products to comply with the latest industry Safety Standards and use state of the art production processes and quality components.

We back the Cycle Boxer with an excellent warranty and a responsive customer service department making it simple and easy to get assistance when needed.

Thank you for choosing Cycle Boxer.

Please thoroughly read this manual before you assemble or operate your Cycle Boxer. Neither Cycle Boxer nor its representatives can accept responsibility for any damages or injury incurred as a result of information presented in this manual except under the terms of the product warranty.

Welcome

Safety First 6

- Children and Pets
- Safety Tips While in Use

Assembling Your Cycle Boxer 8

- Tools & Hardware
- Assembly Instructions
- Leveling
- Seat Adjustment
- Punch Pad Height Adjustment

About Your Cycle Boxer 24

- Heart Rate Monitor with Chest Strap
- Cycle Boxer App
- Pairing Heart Rate Chest Strap with Console
- Pairing Cycle Boxer App to Console
- Program Overview
 - Quick Start Program Group
 - User Challenge Program Group
- Program Setup
 - Quick Start Program
 - User Challenge Program
- Ending a Workout

Maintenance and Tips 46

- Heart Rate Monitoring
- Starting an Exercise Program
- General Maintenance
- Moving the Cycle Boxer
- Specifications
- Warranty

When using exercise equipment, basic precautions should always be followed, including:

- Never drop or insert any object into any opening. If an object falls into an opening, unplug the power cord from the outlet. Remove the object or call technical support at **801-973-9993** option 4.
- Never operate this Cycle Boxer if it has been damaged or partially submersed in water.
- To reduce the risk of electric shock, unplug the Cycle Boxer from the wall outlet when not in use, before performing any maintenance, or before moving the Cycle Boxer.
- Do not use outdoors or in areas of high humidity or extreme temperature changes.
- Do not operate where aerosol spray products are being used or where oxygen is being administered.
- Never place the power cord under carpeting or place any object on top.
- Use this exercise product for its intended use as described in this Owner's Manual. Do not use attachments that are not recommended by Cycle Boxer.
- Keep hands away from all moving parts.
- Keep your Cycle Boxer on a solid, level surface. Do not operate Cycle Boxer on deeply padded, plush or shag carpeting. Damage to carpeting may occur.
- Use caution while participating in other activities while using this exercise equipment, such as watching television or reading. These distractions may cause you to lose balance which may result in injury.

Children and Pets

- When in use children and pets should be kept at least 3 feet (1 m) away.
- This Cycle Boxer can be used by children ages 12 years and above and persons with reduced physical, sensory or lack of experience and knowledge if they have been given supervision or instruction concerning use of the appliance in a safe way and understand the hazards involved.
- Cleaning and user maintenance shall not be made by children without supervision.
- Keep children away from the Cycle Boxer. There are areas that can cause harm and injury.

Safety Tips While in Use

- Always consult a physician before beginning an exercise program.
- If you experience chest pains, nausea, dizziness or shortness of breath, stop exercising immediately and consult your physician before continuing. Do not wear clothing or jewelry that might catch on any part of the Cycle Boxer.
- Wear shoes with high traction rubber soles. Do not wear shoes with heels, leather soles, cleats or spikes.
- Over exercising may result in serious injury or death. If you feel faint stop exercising immediately.
- Keep the Cycle Boxer on a solid surface with a minimum clearance of 2 ft. (.6m) from the front and both sides. Keep a clearance of 3 ft. (.9m) from the back of the Cycle Boxer for safety reasons.

SAFETY CLEARANCE

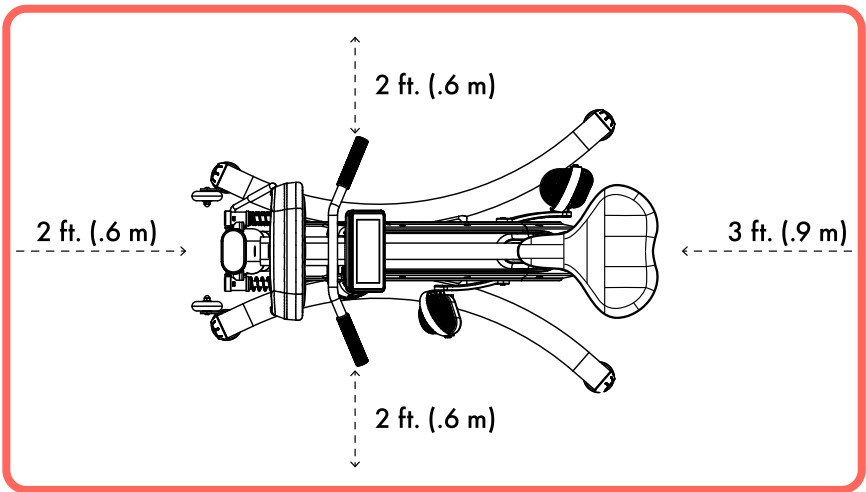

WARNING: Heart rate monitoring systems may be inaccurate. Over exercising may result in serious injury or death. If you feel faint stop exercising immediately.

NOTE: Read all instructions and save for future reference.

Assembling Your Cycle Boxer

Use your phone's camera to scan the QR Code to access the link to watch an assembly video.

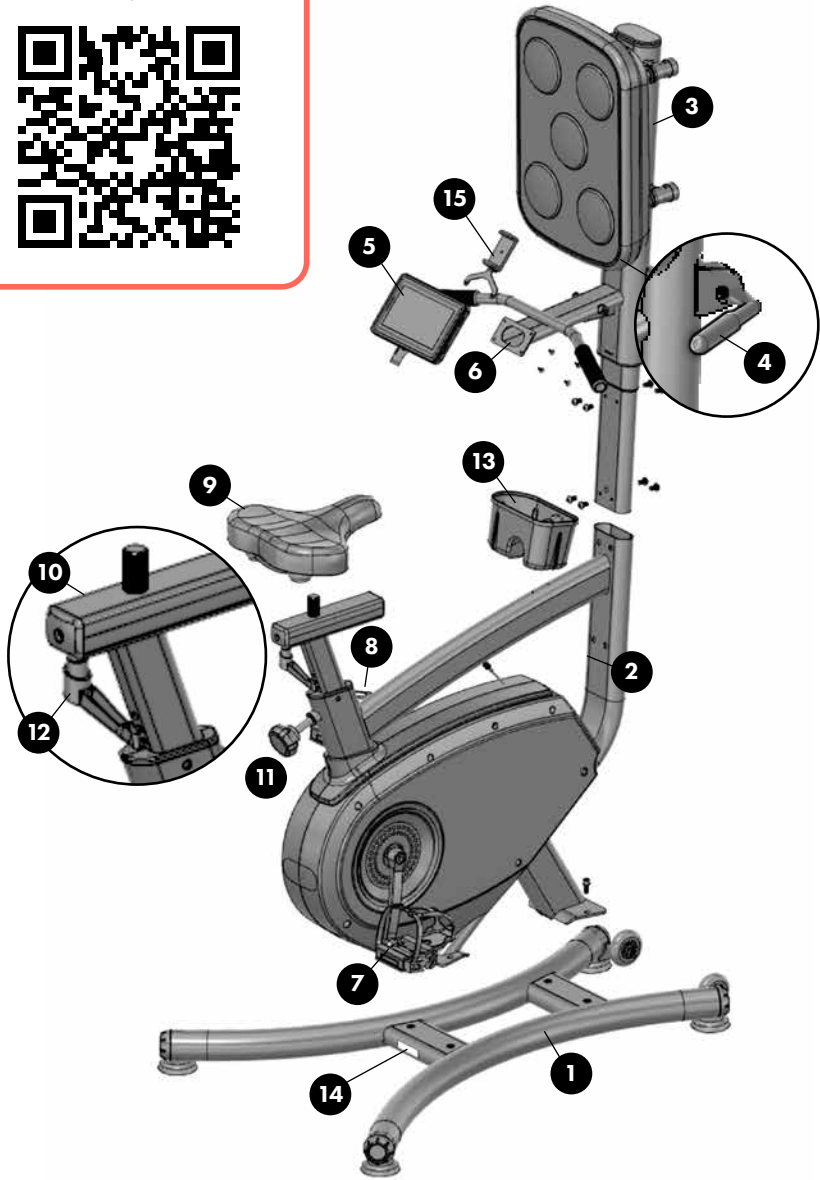
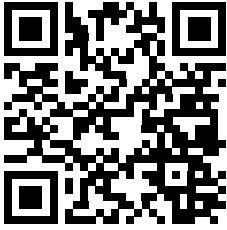

Expanded View

Prior to starting the assembly process take all of the parts out of the box. Remove plastic bags and lay them out on the floor to become familiar with the components.

Since your Cycle Boxer is a heavy piece of equipment it is recommended you use two people during assembly and follow these assembly instructions to reduce any problems that could occur.

Hardware Included

Item#	Part Description	Item#	Part Description
1	Base Frame	9	Seat
2	Cycle	10	Cycle Seat Bracket
3	Punch Pad Post	11	Seat Post Adjustment Knob
4	Punch Pad Lock Handle	12	Seat Fore/Aft Adjustment Handle
5	Console	13	Cup Holder
6	Console Mounting Bracket	14	Serial Number Location
7	Right Pedal	15	Mobile Phone Holder
8	Left Pedal		

Tools

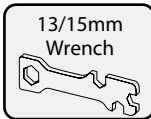

Pre-installed Hardware

Item #	Pre-Installed Hardware
16	M8 x 20L Bolt
17	M8 Washer
18	M8 x 15L Screw
19	M8 Washer
20	M4 x 15L Screw
21	M5 x 15L Screw

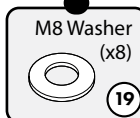
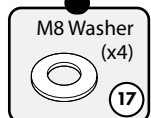
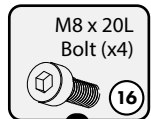

Assembling Your Cycle Boxer

Step 1: Opening Box A

- A. You've received 2 boxes labeled A and B containing the parts you'll need. Cut the straps from both boxes.
- B. Remove the serial number sticker from Box A and place on the back of this manual. This will help you in the future should you need to contact customer service.
- C. Roll Box A on its side and with a razor cut the three taped sides of the bottom of the box.
- D. Open a bottom flap and tip the box back in the upright position.
- E. Tip the box the opposite direction and unfold the other bottom flap.
- F. Lift box up and remove.
- F. Remove tool bag from the top of the Styrofoam.
- G. Remove the Cycle(2) and the Base Frame(1).

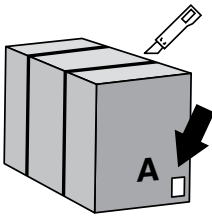

Cuts straps, place serial number sticker on back of this manual

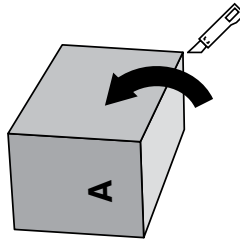

Roll to side, cut tape on three sides

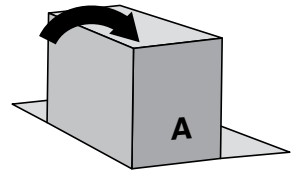

Tip upright, unfold bottom flaps

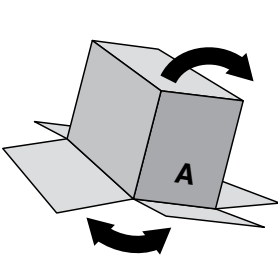

Tip, unfold other flaps

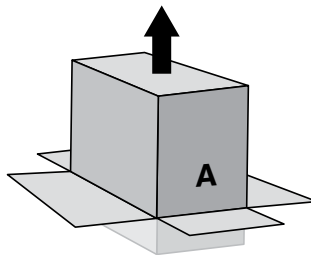

Lift and remove box

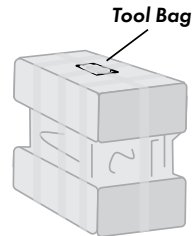

Remove tools, from top of Styrofoam

NOTE: Remove serial number sticker from Box A and place it on the back of this manual should you need to contact customer service.



**CYCLE
BOXER**

Step 2: Attach Cycle to Base Frame

- Remove the four M8 x 20L Bolts(16) and M8 Washers(17) pre-installed in the Base Frame(1).
- Sit the Cycle(2) onto the Base Frame with the front of the Cycle on the same side as the Transport Wheels.
- Align the Cycle mounting holes with the Base Frame holes and re-install the four M8 x 20L Bolts and Washers so they are finger tight, then fully tighten with Allen wrench.

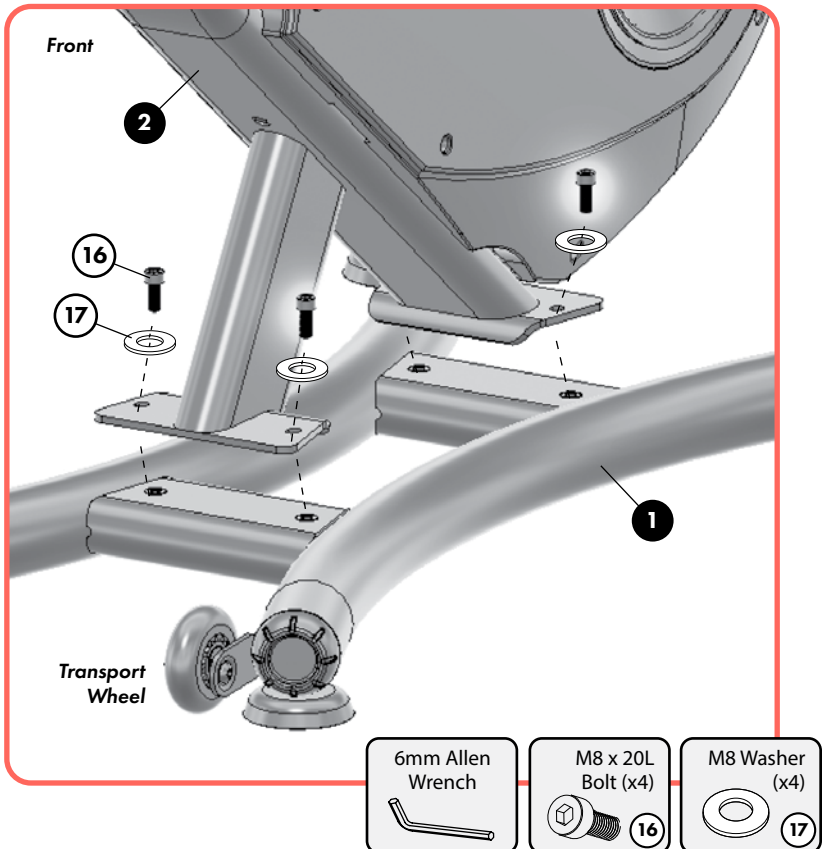

Assembling Your Cycle Boxer

Step 3: Opening Box B

- A. This box contains Punch Pad Post, Boxing Gloves, Console, Pedals, Power Adapter, Heart Rate Monitor with Chest Strap, Cup Holder and Seat.
- B. Remove the box as done in Step 1 for Box A.
- C. Remove from end of Styrofoam the Cup Holder, Pedals, Heart Rate Monitor, and Power Adapter.
- D. Inside the Styrofoam remove the Seat, Gloves, Punch Pad Post, and Console.

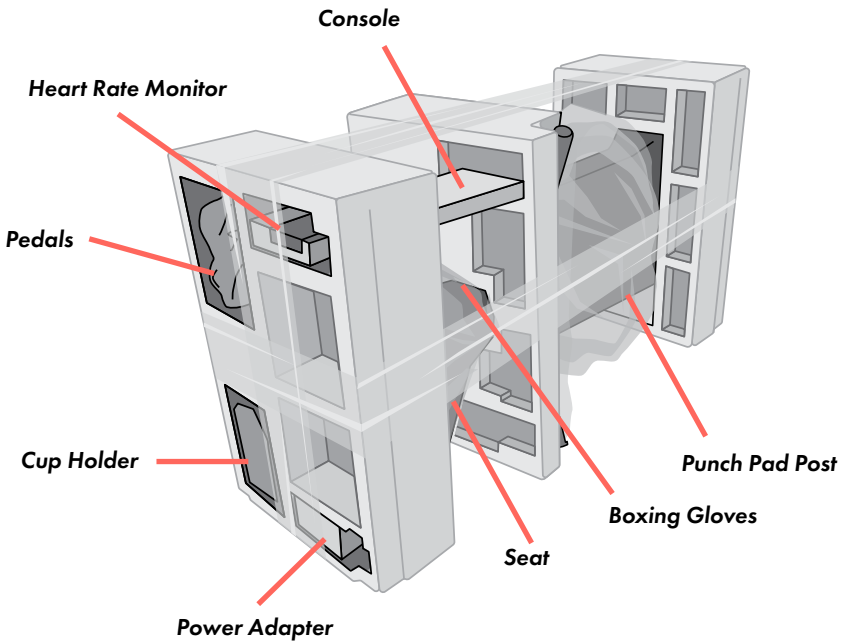

Step 4: Attach the Punch Pad Post to the Cycle

- A. Remove the eight M8 x 20L Screws(18) and M8 Washers(19) from the Punch Pad Post(3).
- B. With the help of a second person hold the Punch Pad Post over the Cycle Frame(2) and attach the two wire connectors. These connectors are oriented in a way that you cannot mess them up.
- C. Carefully insert the two connectors up into the Punch Pad Post and make sure the wires cannot be pinched as you lower the Punch Pad Post down into the Cycle Frame(2).

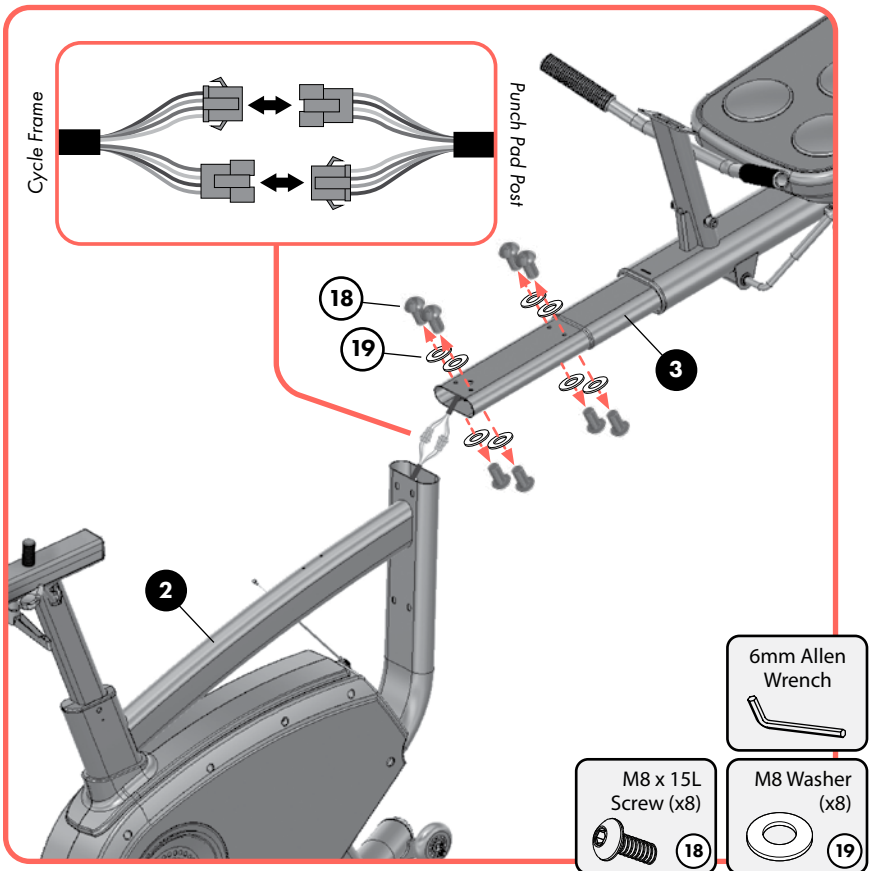

Assembling Your Cycle Boxer

- D. Re-install the eight M8x20L Screws(18) and Washers(19) finger tight. Do not fully tighten until all eight screws are installed. (Hint - When re-installing these eight screws, it may be necessary to pick the Punch Pad Post up slightly to align the threaded holes with the bolts. Do not force the screws, if they do not go in freely, the holes just need to be lined up better.)
- E. Fully Tighten all eight screws.

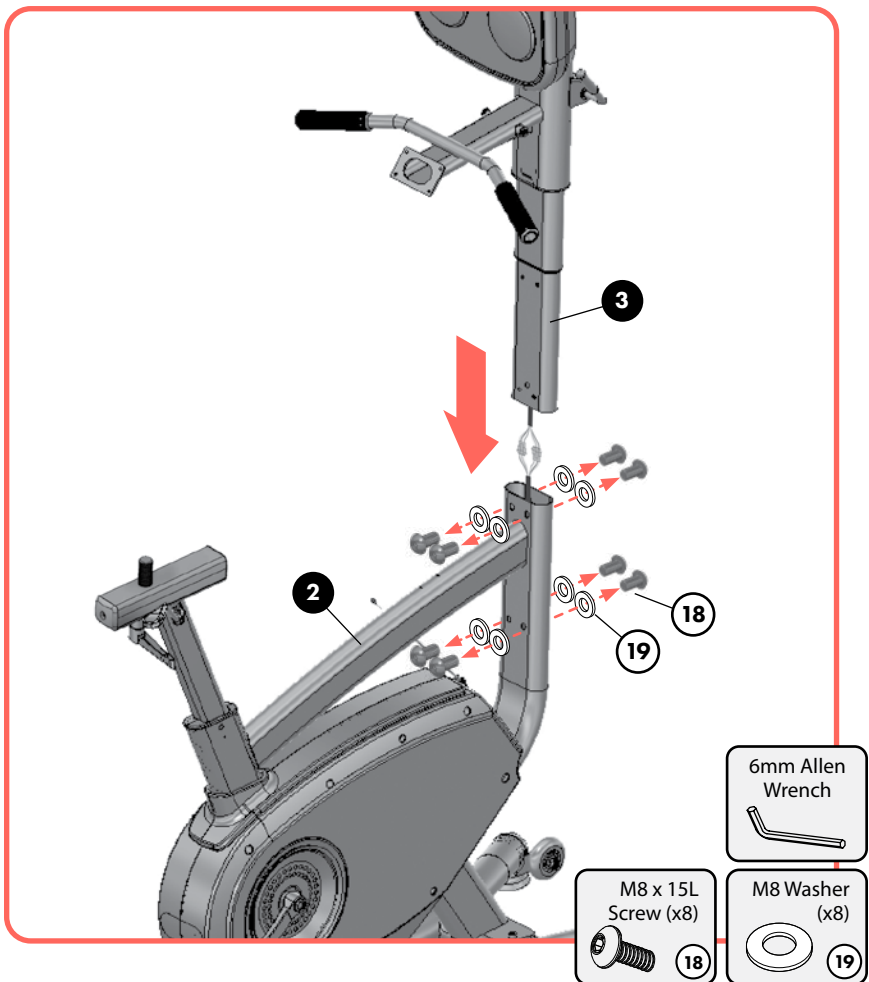

Step 5: Install the Console

- Remove the four pre-installed M4 x 15L Screws(20) from the back of the Console(5).
- Connect the two wire harnesses to the back of the Console.
- With the help of a second person hold the Mobile Phone Holder(15) in place, while carefully tucking any excess wire into the Console Mounting Bracket(6) to protect the wires as you attach the console to the bracket.
- Re-install the four M4 x 15L Screws and tighten.

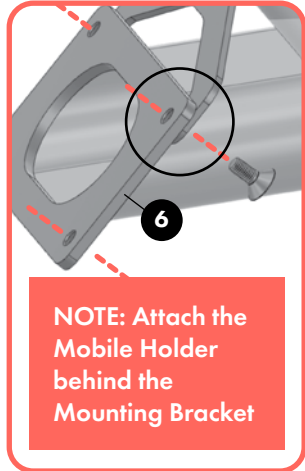
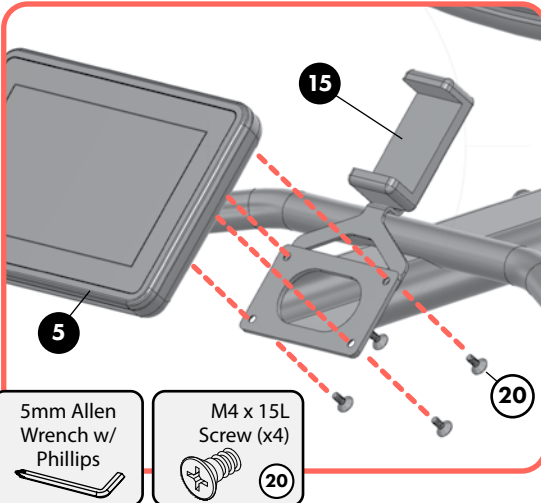
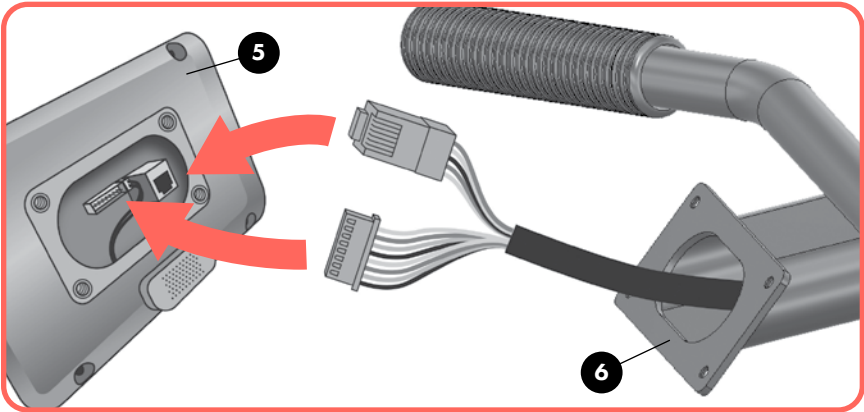

Assembling Your Cycle Boxer

Step 6: Install the Pedals

- Identify which pedal goes on the right side and which pedal goes on the left side by locating the R for Right and the L for Left on the pedal.
- Hand tighten the *Right Pedal*(7) into the right crank arm by turning **clockwise** (Right and Left orientation is determined while sitting on the cycle seat).
- Hand tighten the *Left Pedal*(8) into the left crank arm by turning **counter-clockwise**. Be careful not to cross thread the pedals and crank arms. The *Left Pedal* has reverse threads, so to install and tighten, the pedal threads need to be turned counter-clockwise.
- Tighten both pedals with the provided 15mm wrench.

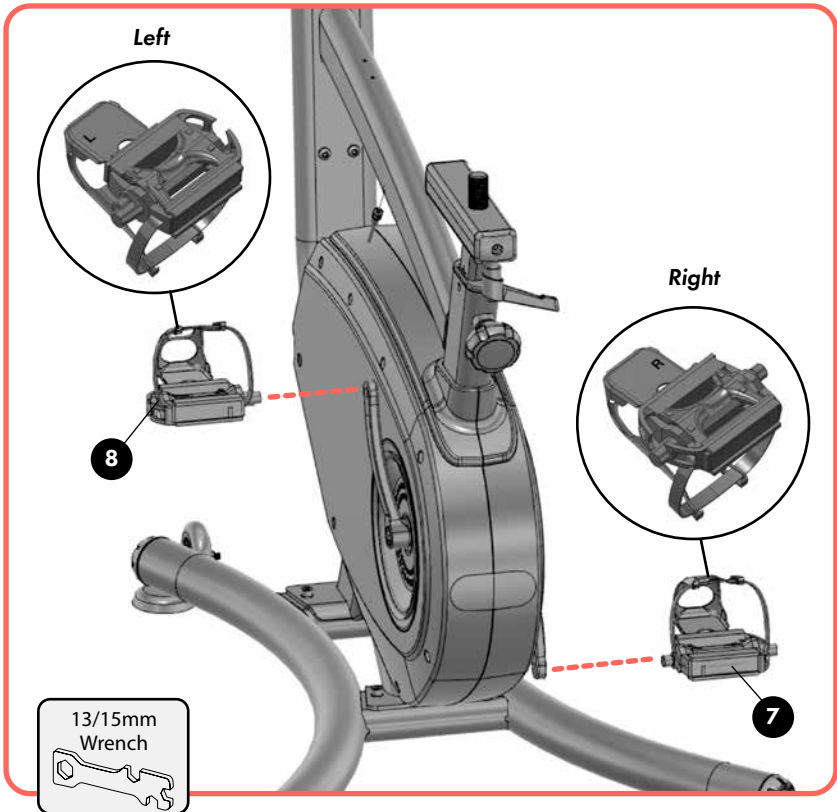

Step 7: Install the Seat

- A. Place the Seat(9) over the Seat Mount Post(A).
- B. Align the Seat(9) so the front of the seat is centered with the Punch Pad Post(3) and parallel to the floor.
- C. Securely tighten the pre-installed Nut(B) on each side of the Seat Mounting Bracket(10) under the Seat(9).

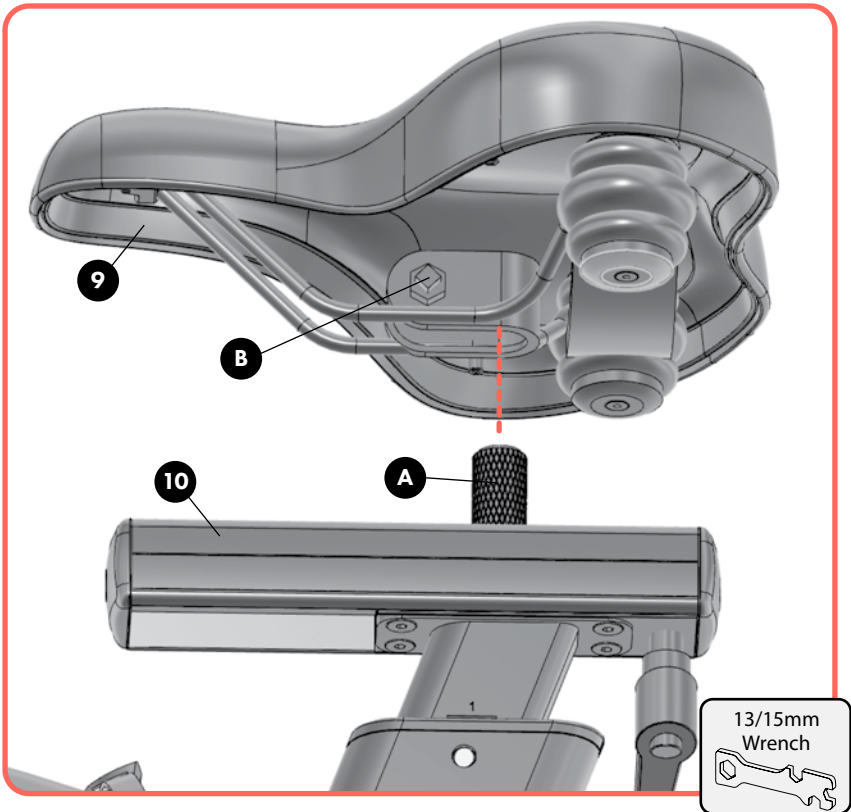

Assembling Your Cycle Boxer

Step 8: Install the Cup Holder

- A. Remove the two pre-installed *M5 x 15L Screws*(21) from the cycle frame.
- B. Align the *Cup Holder*(13) attachment holes with the screw holes in the cycle frame.
- C. Re-install the two *M5 x 15L* screws and tighten.

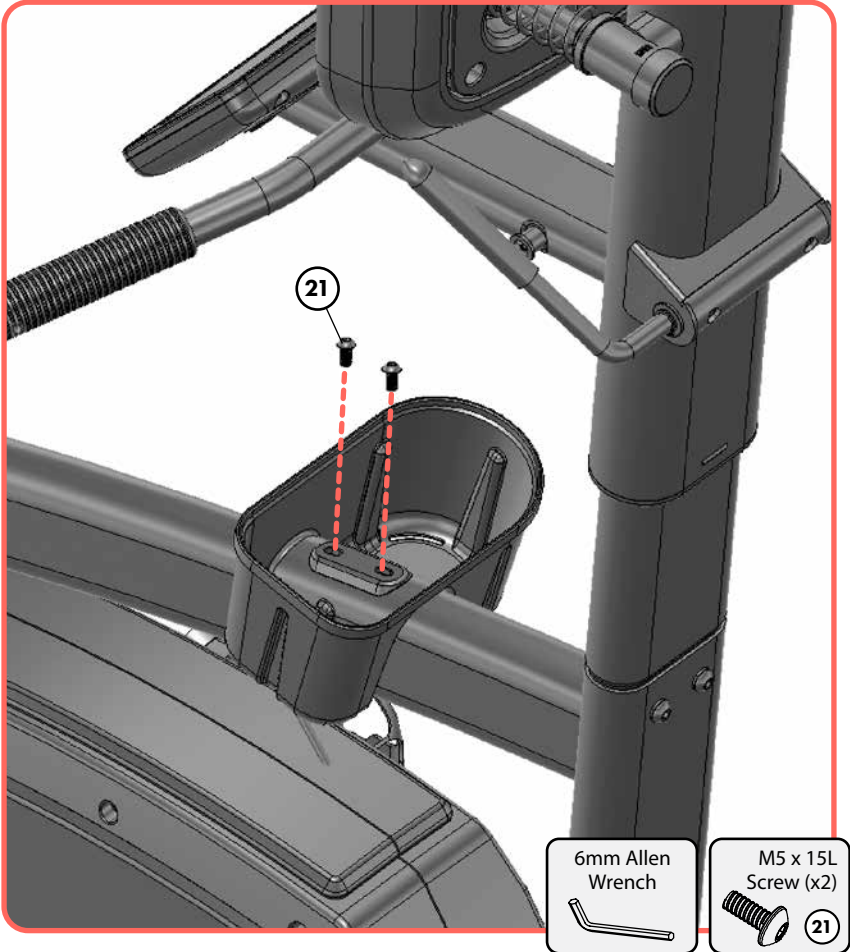

Step 9: Plug-in Power

- A. Connect the *Plug Power Adapter (PA)* in the port located on the bottom front of the *Cycle(2)* and into a wall socket.

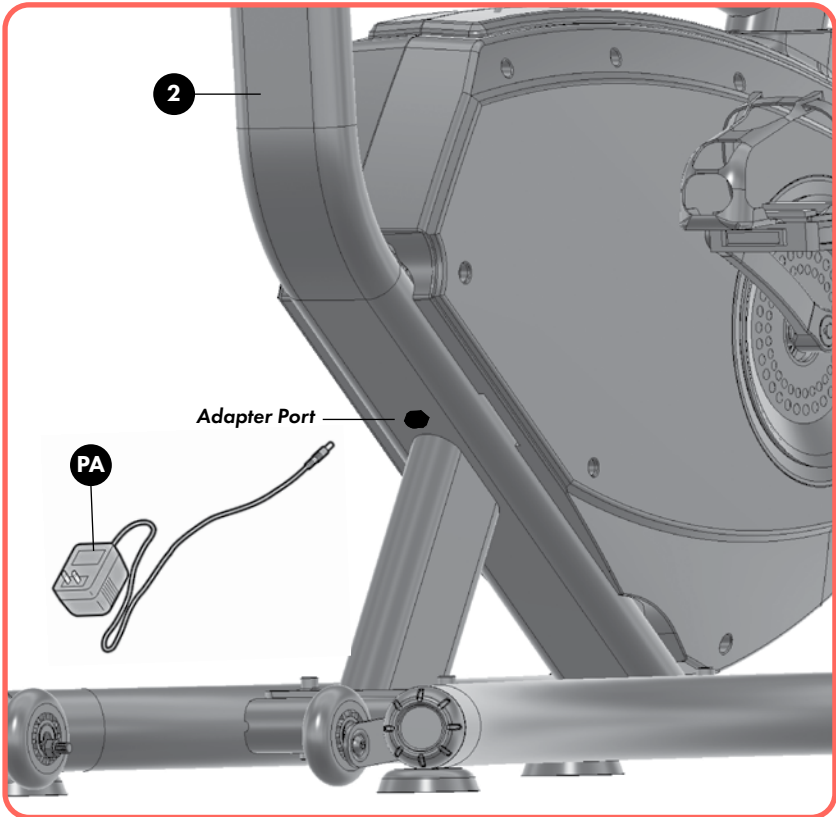

Proper Grounding

LifeSpan equipment must be grounded. Improper connection of the equipment's grounding conductor can result in the risk of electric shock. Check with a qualified electrician or service person if you are in doubt as to whether the outlet is properly grounded. Do not modify the plug provided with the product or use a ground plug adapter to adapt to a non-grounded outlet. If the plug will not fit in the outlet, have the proper outlet installed by a qualified electrician.

Assembling Your Cycle Boxer

Leveling Your Cycle Boxer

Your Cycle Boxer has four adjustment feet that allow you to level the Cycle Boxer to keep the unit solid on the floor. It is not recommended to set the Cycle Boxer up on plush or thick carpeting as it will make the unit less stable while cycling or punching.

For best results in leveling your Cycle Boxer, start by having all four feet screwed all the way in. Lightly rock the unit front to back and side to side. If one or more of the feet is not sitting solid on the floor, screw these feet down till they are sitting on the floor. Retest by rocking the bike and re-adjust as necessary.

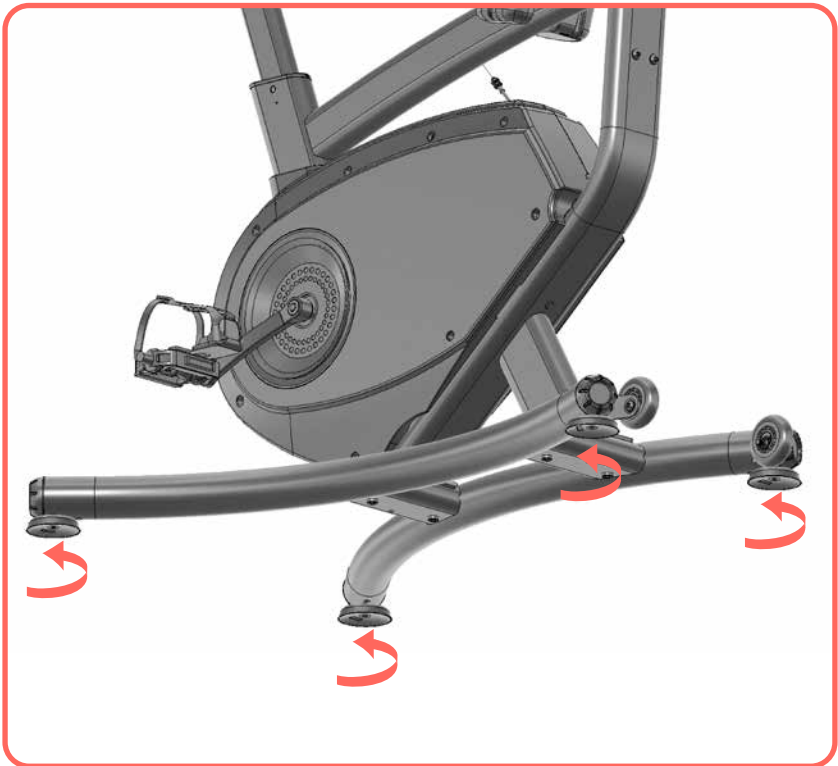

Seat Adjustments

Your Cycle Boxer has two different adjustments that can be made, Height and Fore/Aft adjustment. The seat will move up and down, but also forward and backward.

Height Adjustment – For best results, move the seat post up or down so that your knees are slightly bent while sitting and pedaling on the downward stroke.

- A. Adjust by pulling the *Seat Post Adjustment Knob (11)* with one hand to release the locking pin, then lift the seat up or down with the other hand while still extending the knob. When you reach the desired height, release the *Seat Post Adjustment Knob* to allow the locking pin to engage.

NOTE: The seat height should be in a position so that when the pedal is all the way down in its rotation, your knee should be slightly bent.

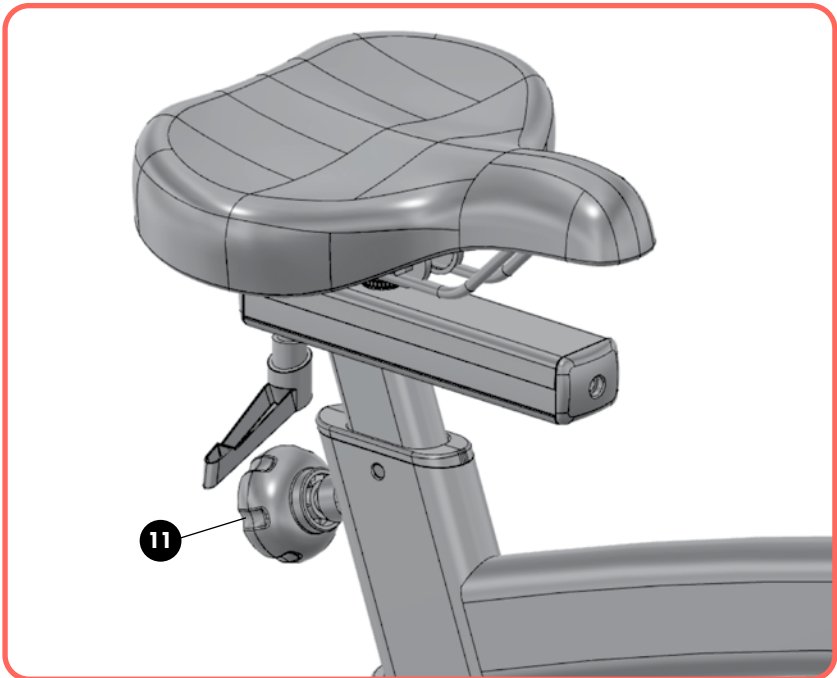

Assembling Your Cycle Boxer

Fore/Aft Adjustment – Stand behind the bike to complete this adjustment

- A. Loosen the *Fore/Aft Seat Adjustment Handle*(12).
- B. To move closer to the Punch Pad, use the handle to push the seat forward. To move further away from the Punch Pad, pull seat back using the handle.

NOTE: The seat should be in a position so that when you punch the punch pad your elbow is slightly bent.

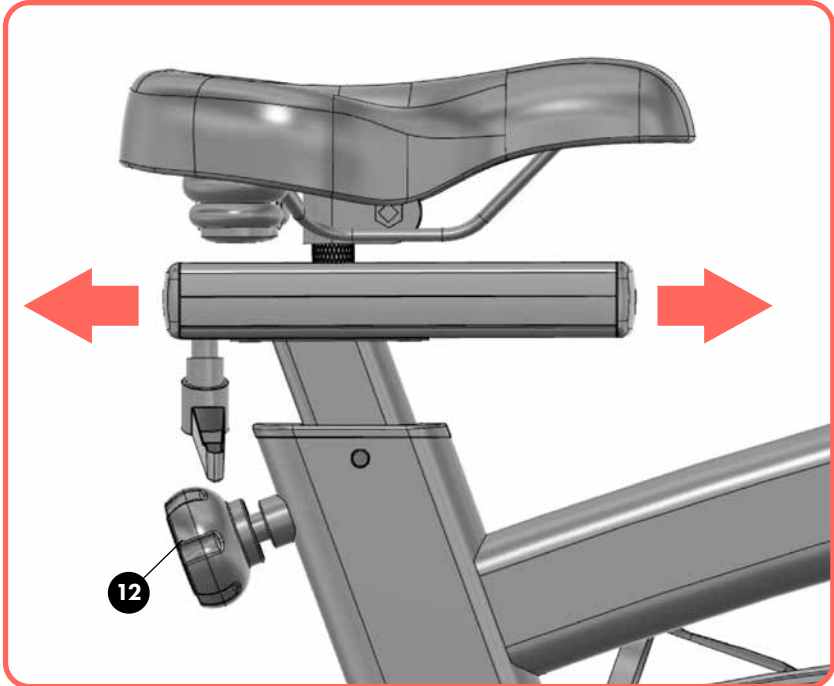



**CYCLE
BOXER**

Punch Pad Height Adjustment

Your Cycle Boxer allows you to adjust the height of the Punch Pad. This allows you to hit the punch pads at the correct angles.

A. Adjusting the Punch Pad up - While sitting on your Cycle Boxer release the *Punch Pad Lock Handle(4)* by pulling the handle up about 90 degrees. This releases the locking mechanism and allows the punch pad to automatically rise. Keep some pressure on the handles and when the pad reaches the correct height, push the lock handle back down into the locked position.

B. Adjusting the Punch Pad Down - While sitting on your Cycle Boxer, release the *Punch Pad Lock Handle(4)* by pulling the handle up about 90 degrees. This releases the locking mechanism and allows you to push down on the handles to lower the Punch Pad. Once the desired punch pad height is reached, push the lock handle back down into the locked position.

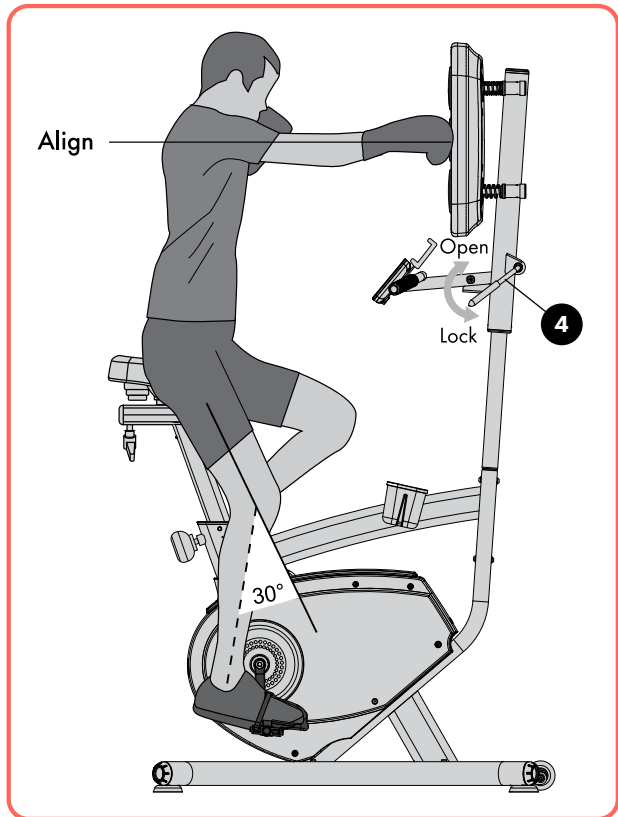

NOTE: The Punch Pad height should be adjusted so that when you reach your arm straight out, your hand is level with the center punch pad.

About Your Cycle Boxer

Heart Rate Monitor with Chest Strap

Your Cycle Boxer has an integrated heart rate receiver built into the console. Also included is a Bluetooth Heart Rate chest strap.

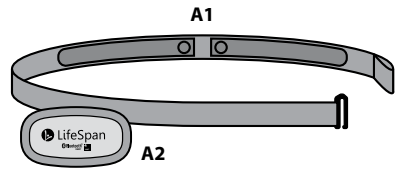

Parts Included

Strap: The electrode areas (fig.A1) on the inside of the strap detect heart rate.

Sensor: The electrodes send the heart rate signal to the receiving device (fig.A2).

Precautions

- If you have an allergic reaction or skin irritation when you are using the sensor, stop using it and consult your doctor.
- With moisture and abrasion, black printing on the surface of sensor might come off and stain light-colored clothing.
- Do not use perfume or insect repellent on skin areas where the heart rate sensors are worn.

Instructions

1. Fasten the sensor to the strap by snapping into place. The LifeSpan logo of the sensor should be in the upright position (fig.B1).

2. Please moisten the electrode areas (fig.A1) for best results.

3. Adjust the length of the strap, so that you can wear it comfortably and it can be securely fastened right below your chest (fig B2).

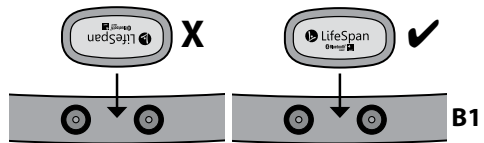

4. Secure the strap around your chest just below the chest muscle, and attach the hook to the other end of the strap (fig. B3).

Getting started

The Heart Rate Monitor is compatible with Bluetooth 4.0/ANT+. It can connect to LifeSpan Fitness products equipped with Bluetooth 4.0 that have an integrated heart rate receiver built into the console.

It can also be paired with mobile devices through iOS and Android (APPs).

When you use the heart rate sensor for the first time, you need to pair the heart rate sensor with your receiving device.

Caring for your Heart Rate Strap

The Heart Rate Monitor is a high-tech instrument that should be handled with care. Follow the care instructions to ensure reliable measurement and maximize the longevity of the heart rate sensor.

Sensor: Detach the sensor from the strap after every use and dry the connector with a soft towel. Clean the sensor with a mild soap and water when needed. Never use alcohol or any abrasive material (e.g., steel wool or cleaning chemicals).

Strap: Rinse the strap under running water after every use and hang to dry. Clean the strap gently with a mild soap and water when needed. Do not use moisturizing soaps, because residue will be left on the strap. Do not stretch the strap or bend the electrode areas sharply.

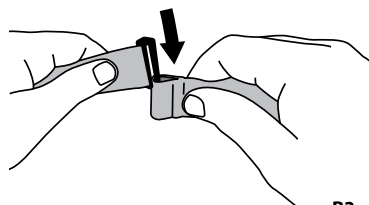

B3

About Your Cycle Boxer

Dry and store the strap and the sensor separately to maximize the battery life. Keep the heart rate sensor in a cool and dry place. Do not store the heart rate sensor in non-breathing materials, such as a sports bag, to prevent snap oxidation. Do not expose the heart rate sensor to direct sunlight.

Technical Specifications

Battery type : CR2032 (900 hours)

Operating temperature : 0-50 °C / 32-122 °F

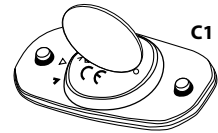

Changing Battery

To change the battery, use a coin to turn the battery cover counter-clockwise to “▲”. (fig. C1)

Insert a new battery (CR2032) with the positive pole (+) facing up. Make sure the plastic sealing ring is seated in the groove to ensure water resistance.

To close, replace the battery cover with the arrow pointing to “▲” and turn the battery cover clockwise to “▲”.

! WARNING: Keep battery away from children. If it is swallowed, contact the doctor immediately. The battery should be disposed in compliance with local regulation.

! CAUTION: Risk of explosion if you insert battery with incorrect type.

Heart Rate Monitor Warranty

The Heart Rate Monitor has a one-year warranty from the date you purchase it. LifeSpan will replace the Heart Rate Monitor if it does not work and meets the following criteria.

- Limited warranty valid in North America only.
- The warranty does not cover the battery, damage due to misuse, abuse, accidents or non-compliance with the precautions; improper maintenance and elastic strap.
- The warranty does not cover any damage, losses, costs or expenses, directly or indirectly related to the product.
- Items purchased second-hand are not covered with this warranty, unless otherwise stipulated by local law.

Should you need to process a warranty claim, make sure you retain your purchase receipt to verify the date of purchase.

“Cycle Boxer” App

Download and install the Cycle Boxer App from Google Play or the App Store. Login via Twitter, Facebook or a guest account and enter or edit your profile. Once you’ve entered your profile and selected Start, your information will be saved and you are ready to use the App.

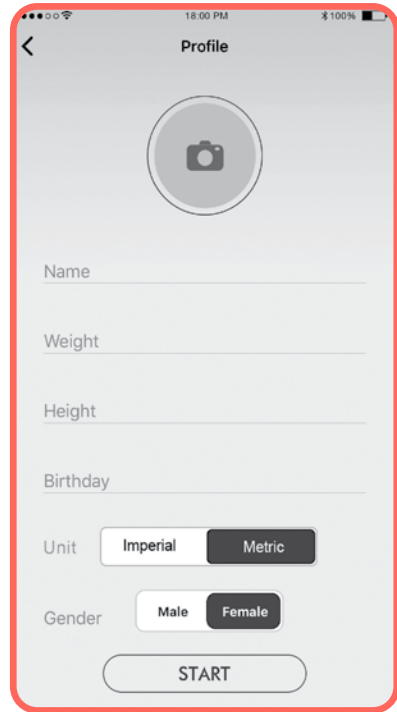
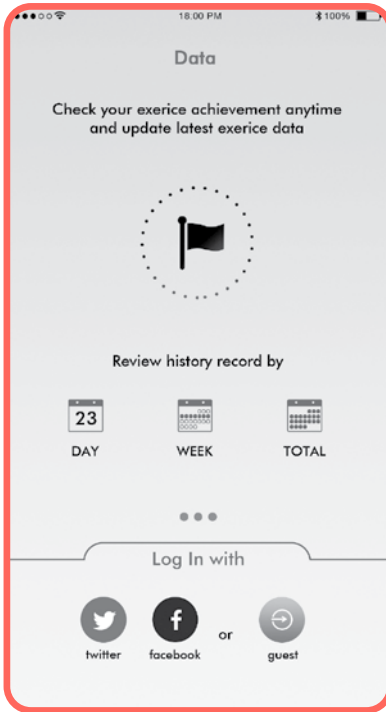

The Cycle Boxer App works two ways, it allows you to simply sync your workout data from your Cycle Boxer console or it allows you to set up an actual workout and send the workout to your console. Either way, your data can be saved in a single location and will allow you to see data with total scores from your latest workouts, data based on your weeks of workouts and your total scores.

About Your Cycle Boxer

Pairing your Bluetooth Heart Rate chest strap with your Console:

A. From the home screen, touch the Bluetooth button on the bottom of the screen.

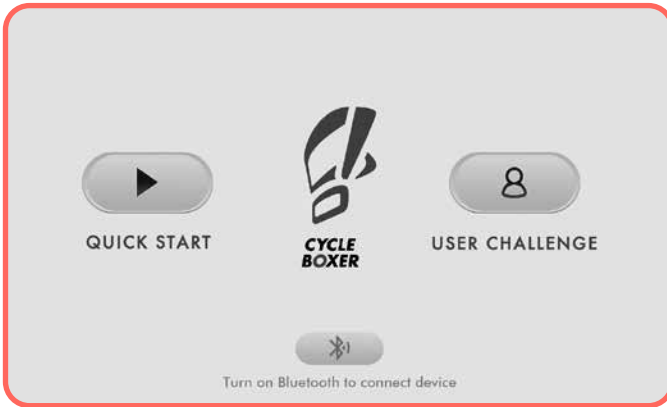

B. Select the HR Strap button.

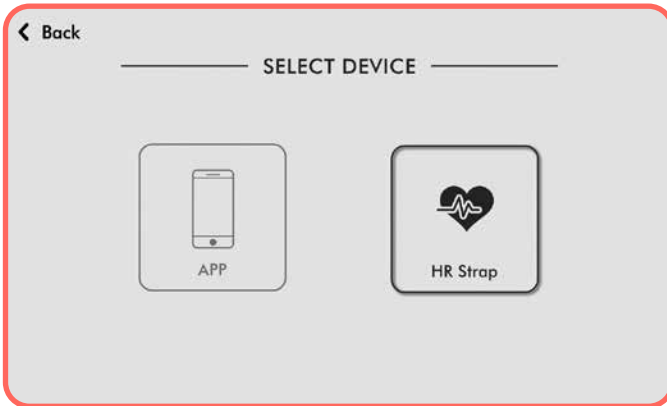



**CYCLE
BOXER**

1. Make sure your Bluetooth Heart Rate Strap is securely fastened and the contact pads are making good contact with your skin.
2. The Bluetooth Heart Rate Strap will send a signal to the display and the HR strap serial number will display on the screen. (THR10-00000) is the serial number to look for, however the last 5 digits will be something other than 00000.
3. Touch the serial number on the screen to pair. When a blue Bluetooth icon appears beside the serial number, you are paired and ready to go.
4. Touch the back button twice to get back to select a program.



About Your Cycle Boxer

Pairing the Cycle Boxer App to the Console:

A. From the home screen, touch the Bluetooth button on the bottom of the screen.

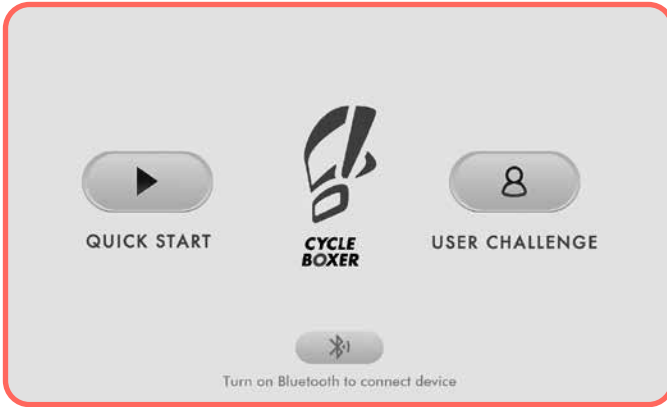

B. Select the APP button.

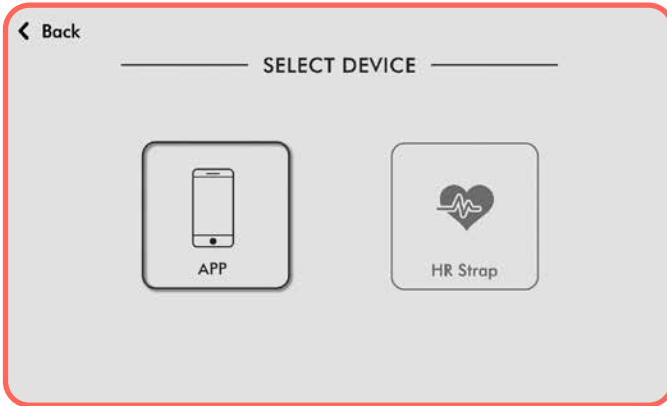

1. Click on CB button on top left corner of phone App screen.

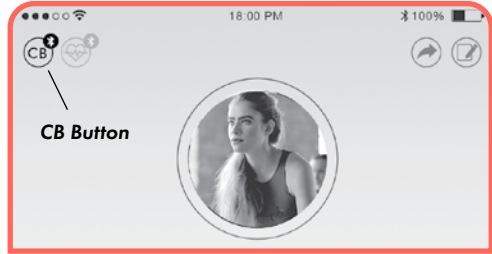

2. Press sync on the console.

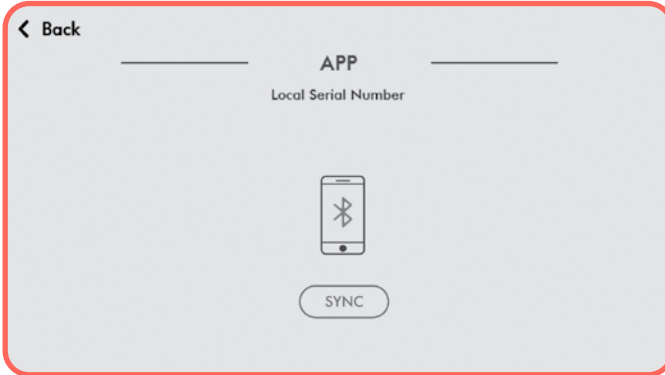

3. Pairing may happen automatically, if not, select the device based on the local Serial number as shown on the console screen.

4. At this time your phone should be paired to the console.
5. Touch the back button twice to get back to select a program.

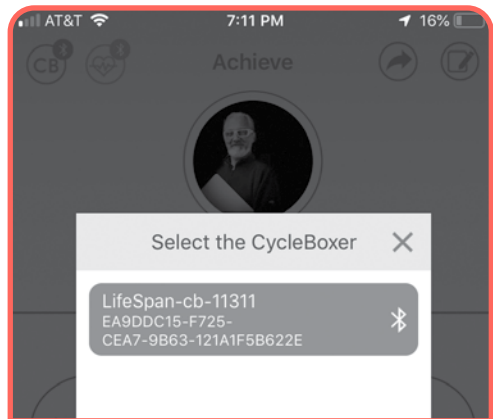

About Your Cycle Boxer

Program Overview

There are two basic program groups, **Quick Start** and **User Challenge**. There are three levels under each group, Easy, Medium, and Hard. There is also a tutorial (Tutor) that gives the information on how to use the selected program and mode.

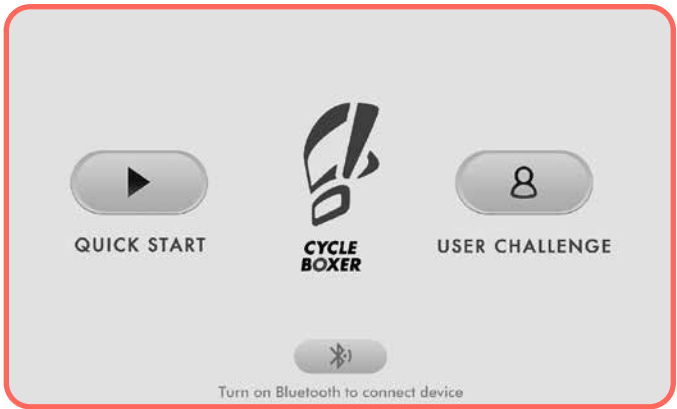

Quick Start Program Group



- A. **Easy (No Crossover)** – Selecting Easy simply takes you to the start screen where the workout can be started. This level allows you to punch the pads with either hand. Simply punch the pads when they light up.



**CYCLE
BOXER**

- B. **Medium (Crossover)** – This level allows you to select Color Mode or Shape Mode.
1. If Shape is selected, the user will punch a cross shape with their right hand and a square shape with their left hand. This level also requires the user to crossover punch which means punch left pads with right hand and right pads with left hand. The middle pad can be punched with either hand.
 2. If Color is selected, the user will punch the Blue lit pads with their Right hand, the Green lit pads with their left hand and the Yellow lit pads with either hand.

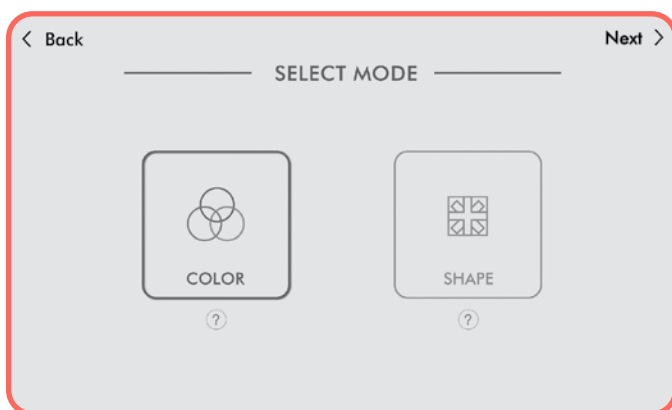

- C. **Hard (Random)** – This is a random punching pattern where there will be both crossover and non-crossover punching. This level allows you to select Color Mode or Shape Mode.
1. If Shape is selected, the user will punch a cross shape with their right hand, a square shape with their left hand and the middle pad with either hand. This level will utilize both crossover and non-crossover for a completely random punch sequence.
 2. If Color is selected, the user will punch the blue lit pads with their right hand, the green lit pads with their left hand and the yellow lit pads with either hand. This level will utilize both crossover and non-crossover for a completely random punch sequence.

About Your Cycle Boxer

User Challenge Program Group

- A. The User Challenge Program Group acts exactly like the Quick Start Group except this group allows the user to setup 3 more options- Rounds, Resistance and Speed
 - 1. Rounds – The user can set up the number of Rounds they would like to go in this program. User can select up to 10 Rounds, each round is 3 minutes.
 - 2. Resistance – The user can set the amount of pedal resistance they would like during the workout. Resistance levels range from 1 (easiest) to 16 (hardest)
 - 3. Speed – The user can select the speed at which the Pads light up to increase punching speed. Punching speed ranges from 1 (slowest) to 12 (fastest).
- B. The User Challenge Programs allow for more adjustments to meet your workout needs.

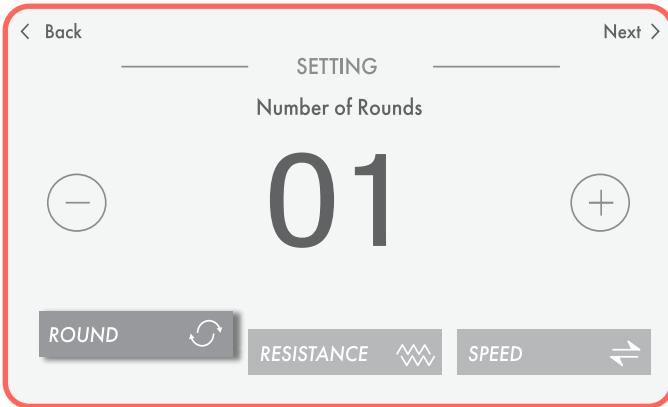

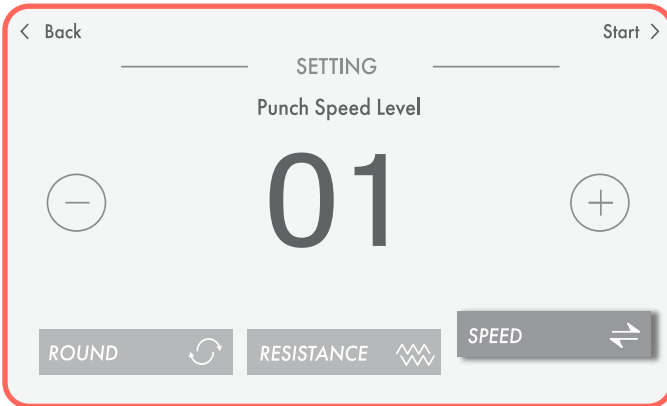
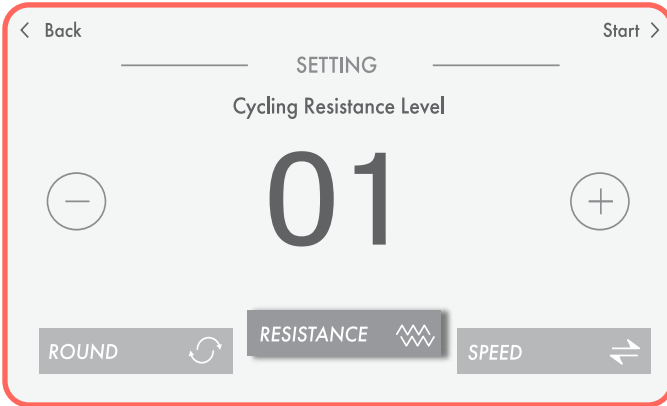

About Your Cycle Boxer

Program Setup

Prior to starting a workout, review product adjustment sections in this manual. Once Cycle Boxer is adjusted to your size, put the included gloves on.

NOTE: The included gloves are designed specifically to recognize a left punch from a right punch. Use of any other glove will not work.

Quick Start Program

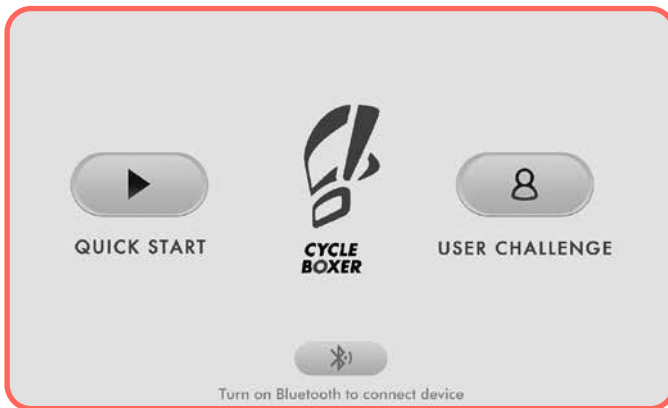

- A. From the home screen, select Quick Start.
- B. Easy is highlighted by default.

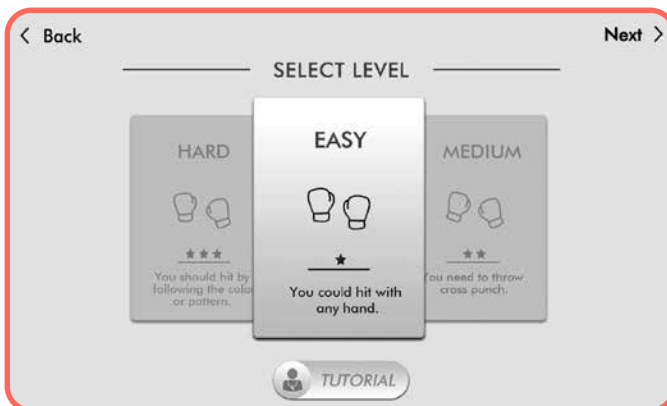

1. To use this program press Next in the upper right corner of the screen.
 2. Press Start on the next screen.
- C. Touch the right scroll arrow to move to Medium or Hard
1. To select Medium or Hard, highlight the desired program and touch Next in the upper right corner of the screen.
 2. Select Shape or Color Mode by touching the mode you want to use and Press Start in the upper right corner of the screen.
 3. Press Start on the next screen.

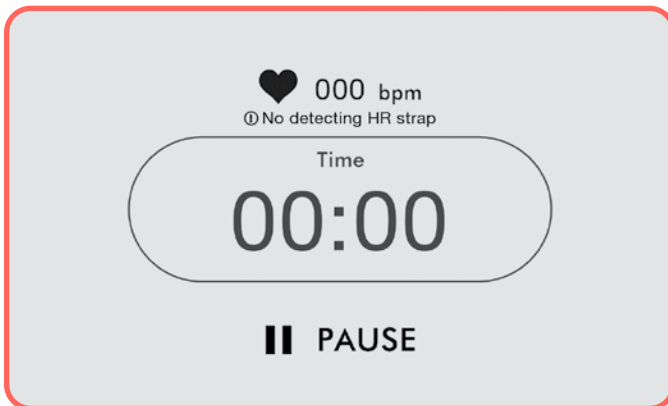
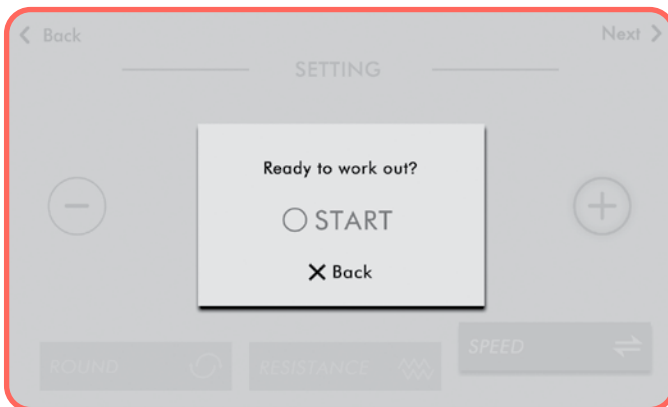

About Your Cycle Boxer

D. At the end of each three minute round there will be a one minute rest period, where you will see a summary of your workout. You can skip the rest period, pause if you need more time, or finish the workout from this screen.

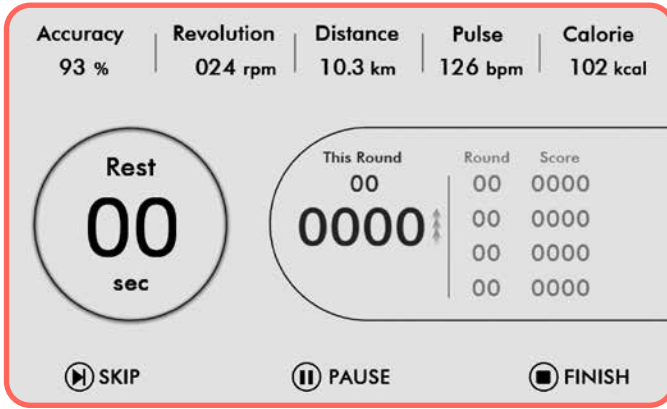

- E. Touch the right scroll arrow to move to highlight Tutor
1. Press Next in the upper right corner of the screen.
 2. Touch Color or Shape Mode and press Start in the upper right corner of the screen.
 3. View the tutorial on how to use the selected program Mode.
 4. Touch Back to go back and select the Mode you would like to begin.

User Challenge Program

A. From the home screen, select User Challenge.

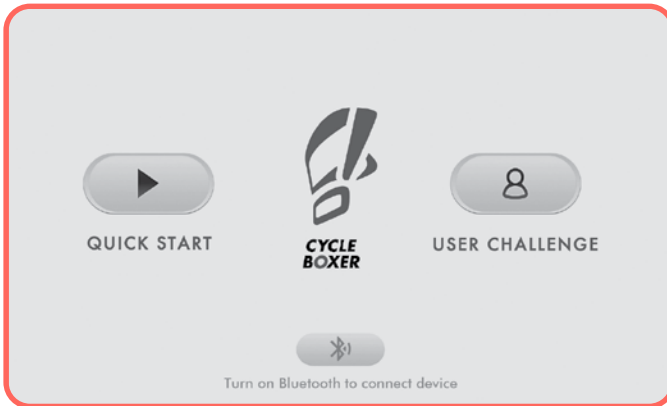

B. Easy is highlighted by default – to use this program:

1. Press Next in the upper right corner of the screen.
2. Adjust the number of Rounds, Cycling Resistance and Punch Speed
 - a. To adjust Number of Rounds simply press Rounds and then press the plus or minus buttons to get to the desired number of Rounds (Up to ten Rounds at three minutes each)
 - b. To adjust Cycling Resistance, press Resistance button and use the plus or minus buttons to get to the desired level of Resistance (1 – 16, 16 being the hardest resistance).
 - c. To adjust the Punch Speed, touch the Speed button and use the plus or minus buttons to get to the desired level of Speed (1 – 10, 10 being the fastest).
3. Press Start on the upper right corner of the screen.
4. Press Start on the next screen.

About Your Cycle Boxer

C. Touch the right scroll arrow to move to Medium or Hard.



1. To select Medium or Hard, highlight the desired program and touch Next in the upper right corner of the screen.
2. Select Shape or Color Mode by touching the mode you want to use and Press Next in the upper right corner of the screen.
3. Adjust the Number of Rounds, Cycling Resistance and Punch Speed.

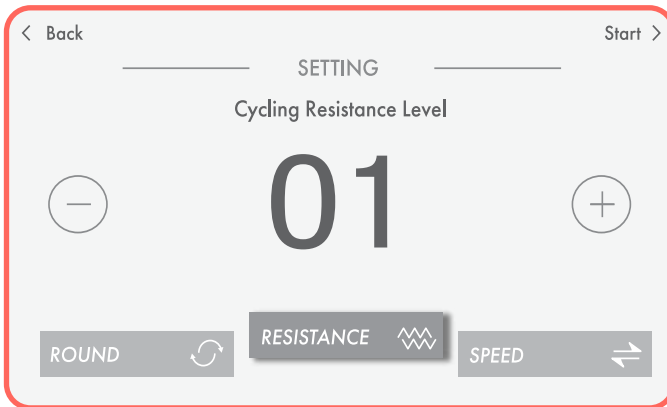

- a. To adjust Number of Rounds simply press Rounds and then press the plus or minus buttons to get to the desired number of Rounds (Up to ten Rounds at three minutes each).
- b. To adjust Cycling Resistance, touch Resistance button and use the plus or

- minus buttons to get to the desired level of resistance (1 – 16, 16 being the hardest resistance).
- c. To adjust the Punch Speed, press the Speed button and use the plus or minus buttons to get to the desired level of Speed (1 – 12, 12 being the fastest).
4. Press Start in the upper right corner of the display.
 5. Press Start on the next screen.

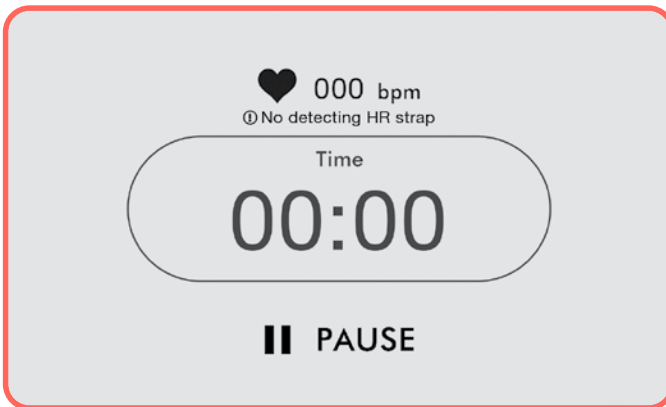
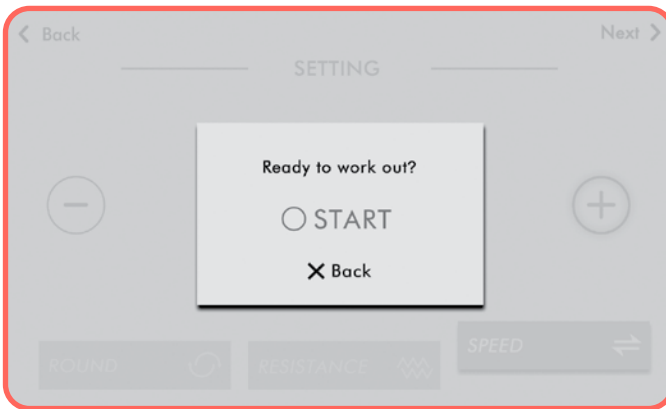

About Your Cycle Boxer

- D. At the end of each three minute round there will be a one minute rest period, where you will see a summary of your workout. You can skip the rest period, pause if you need more time, or finish the workout from this screen.

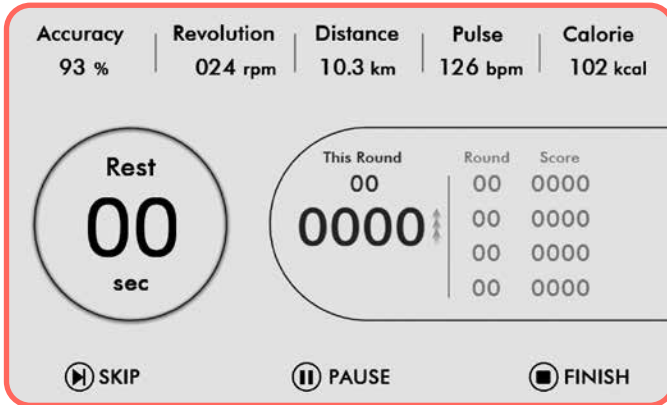

- E. Touch the right scroll arrow to move to highlight Tutor
1. Press Next in the upper right corner of the screen
 2. Touch Color or Shape Mode and press Start in the upper right corner of the screen.
 3. View the tutorial on how to use the selected program Mode.
 4. Touch Back to go back and select an actual program and Mode.

Ending a Workout

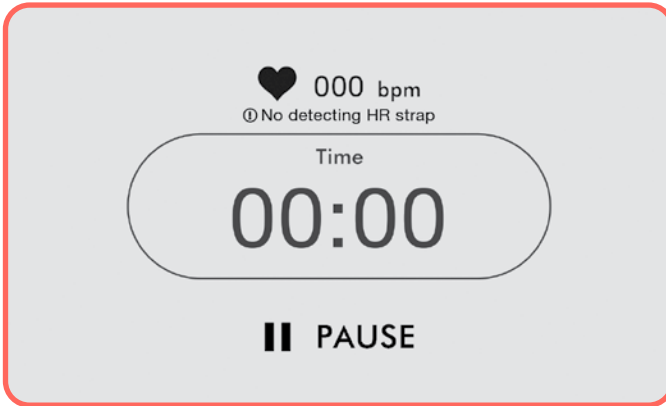

Pressing Pause at any time during a workout will allow the user to select finish to end their workout, or press Start to continue the workout. Once Pause is pressed you will have five minutes before the workout ends automatically.

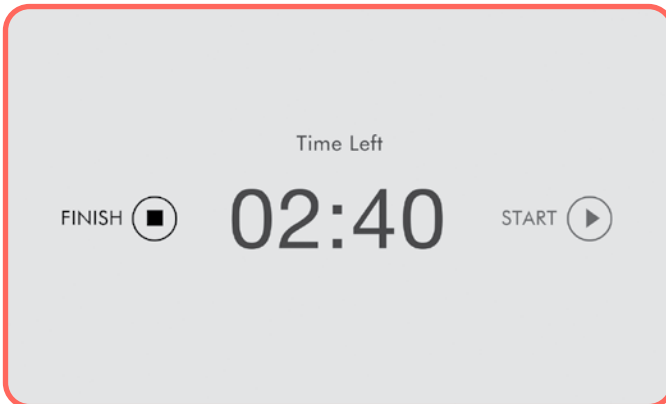

- A. Pressing Start takes you to the normal start screen and allows you to continue your workout.
- B. Pressing Finish takes you to a group of three detailed summary screens.

About Your Cycle Boxer

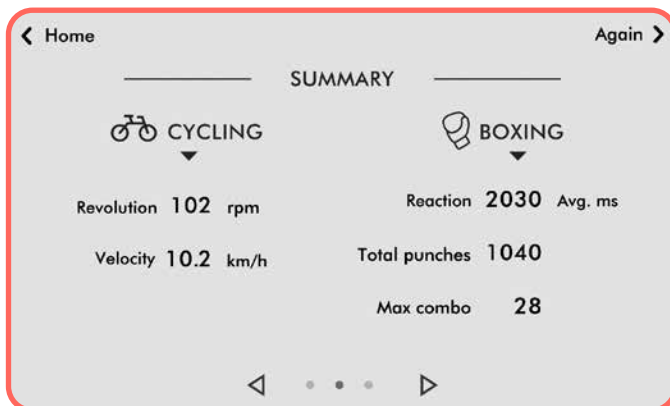
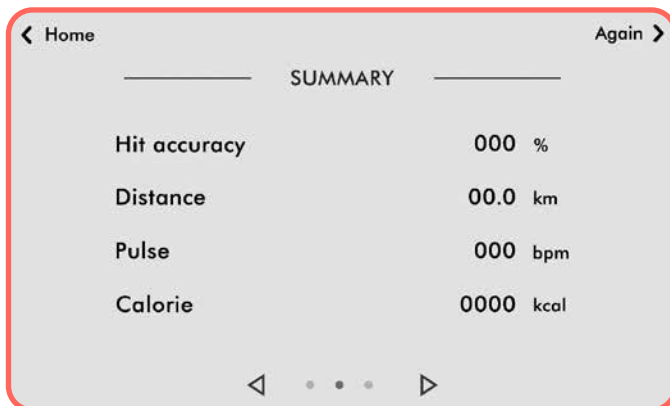
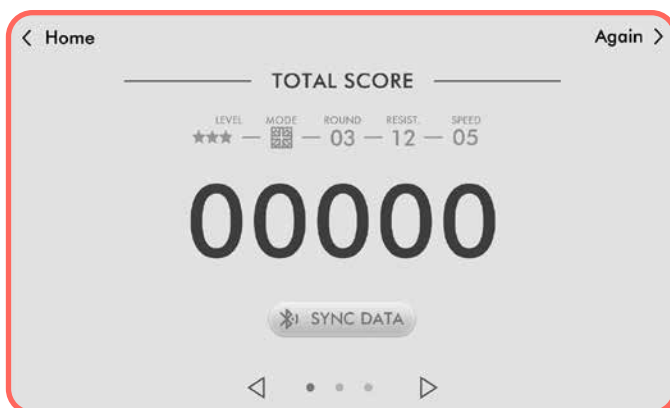

- C. If you would like to repeat the same workout without going through the setup process, press Again in the upper right corner of the summary screen.
- D. Sync your data with the app.
 - 1. If your App is not paired to the Cycle Boxer console at this time
 - a. Be sure your phone Bluetooth is turned on.
 - b. Touch the Cycle Boxer Bluetooth button on the top left corner of the screen.

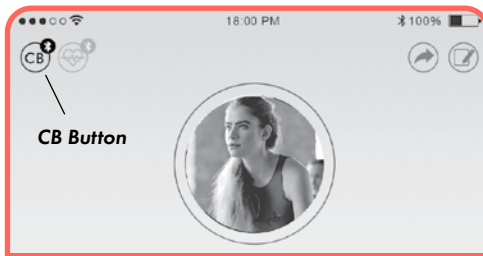

- c. On the Cycle Boxer screen touch the Unconnected button.
- 2. Pairing may happen automatically, if not, select the device based on the local serial number as shown on the console screen.
- 3. At this time your phone should be paired to the console.
- 4. Press Sync Data.
- 5. Data should be updated to the App.

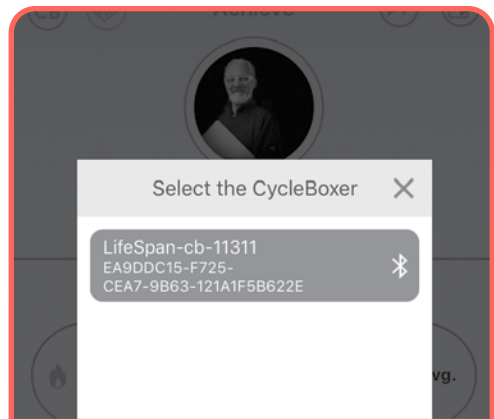

Maintenance and Tips

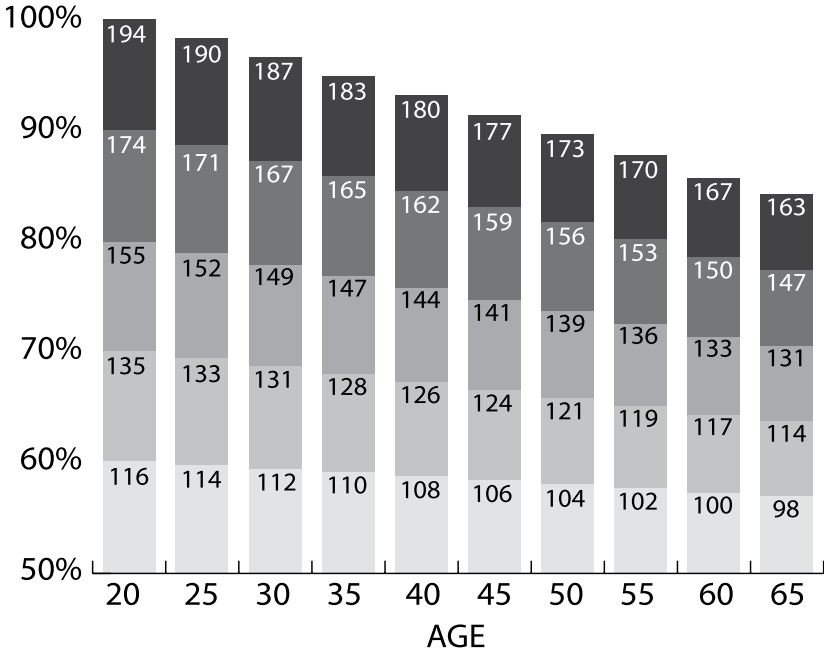

Heart Rate Monitoring

Seeing your heart rate while exercising will help you understand the intensity of your exercise and corresponding heart rate training zone, and predict health benefits found through repeated bouts of exercise. Refer to the information below to understand your heart rate training zones:

Zone 5 — Performance Redline Zone: 90% - 100% of your Max HR

The performance zone involves extreme effort, requiring the heart to beat at or near maximum capacity. Training bouts include intense incline or sprinting, benefiting speed, power, and anaerobic performance competency.

Zone 4 — Threshold Zone: 80% - 90% of your Max HR

The threshold zone involves intense jogging or sub-maximal sprinting, typically unsustainable for long periods of time. Benefits include highly-elevated calorie burn, speed and power performance enhancement, improved lactate removal capabilities, and enriched heart health.

Zone 3 — Aerobic Zone: 70% - 80% of your Max HR

The aerobic zone is ideal for cardiovascular training. Workouts in this zone are more intense, involving moderate jogging. Long-term benefits are improved heart health and cardiovascular performance, reductions in blood pressure and cholesterol, and increased calorie burn.

Zone 2 — Temperate Zone: 60% - 70% of your Max HR

The temperate zone consists of moderate-intensity exercise, typically as fast walking to slow jogging. Speaking is more difficult and breathing is elevated. Benefits are similar to those of the healthy heart rate zone, though caloric expenditure is higher.

Zone 1 — Healthy Heart Zone: 50% - 60% of your Max HR

The healthy heart zone involves safe, low-intensity activity, like medium-to-brisk walking. Full conversations can be held, despite a gentle increase in respiration. Benefits include reduced risk of heart and vascular disease, moderated blood pressure and cholesterol, and improved insulin sensitivity.

Starting an Exercise Routine

Starting a workout schedule can sound like a daunting task, but just remember that your main goal is to boost your health by meeting the basic physical activity recommendations.

Before you begin or substantially increase your level of activity, be sure to consult your primary care physician. In preparation for a visit you may also want to take the PAR-Q Assessment. The Physical Activity Readiness Questionnaire (PAR-Q) will help you determine your suitability for beginning an exercise program and prepare you for discussing your physical activity program with your physician.

1. Have you ever been told by your doctor that you have a heart condition? Or that you should participate in physical activity only as recommended by a doctor?
2. Do you feel pain in your chest during physical activity?
3. In the past month, have you had chest pain when you were not doing physical activity?
4. Do you lose your balance because of dizziness?
5. Do you ever lose consciousness?
6. Do you have a bone or joint problem that could be made worse by a change in your physical activity?
7. Is your doctor currently prescribing drugs for your blood pressure or a heart condition?
8. Do you know of any reason you should not participate in physical activity?

If you answered yes to one or more of the questions, if you are over 40 years of age and have been inactive or if you are concerned about your health, consult a physician before beginning an exercise program or substantially increasing your physical activity. If you answered no to each question then it's likely you can begin an exercise program.



**CYCLE
BOXER**

General Maintenance

1. Keep your Cycle Boxer clean and dry. It is a good idea to wipe the unit down after each workout
2. If the unit is not going to be used for an extended period of time, it is a good idea to unplug the unit and store in a clean/dry environment.
3. Clean only with mild soap and slightly damp cloth. Never use solvents when cleaning.

Moving the Cycle Boxer

To move your Cycle Boxer to a new location, stand in front of the unit. Use one foot to brace against a transport wheel. Grab the area of the frame as close to the top of the punch pad as possible. Tilt the unit toward you. You will need to tilt the unit far enough forward so that the weight of the unit transfers to the wheels. Push or pull the unit to the desired location then lower the unit back down onto all four feet.

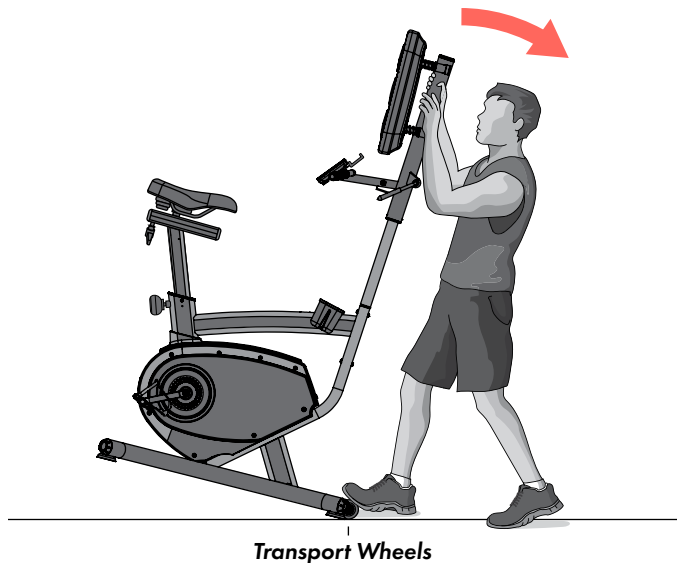

⚠ CAUTION: When tilting the unit use proper safety precautions. If the unit is too heavy have a friend help you. Brace one of the transport wheels with one foot to help tilt the unit forward. Move the unit once the weight is on the wheels.

Specifications

Mechanical and Performance

Seat	Molded, contoured seat
Seat Height Adjustment	Between 34.25" x 42.12"
Resistance System	Magnetic Eddy Current Brake
Seat Fore/Aft Adjustment	4" Forward Backward Adjustment
Power	Input: 100-240V AC, 50-60 HZ 0.8A Output: 12VDC 1.5A
Flywheel Weight	13.2 lbs / 6 kgs
Product Weight	121 lbs / 55 kgs
Max. User Weight	300 lbs / 136 kg
Dimensions	43.6" x 27" x 63-74.5"
Transport Wheels	Front Mounted * 2

Console Features

Readouts	Program Name, Tutor, Date & Time, Workout Time, Rest Time, Round, Speed, Resistance, Calories, Summary, Cycle Revolutions, Pulse, Score, Punch-Reaction Time, Punch Accuracy, Max Combo; Cycling-Distance, Cycle Velocity, Bluetooth, APP
Programs	Quick Start Program(3), User Challenge(3)
Display	7" TFT touch panel
Bluetooth	Yes, for Heart rate Receiver & APP
Speaker	Yes
Rounds	1 to 10
Resistance levels	16 Levels
Punch Speed Levels	12 Levels



Cycle Boxer Warranty

This Cycle Boxer comes with the following limited warranty valid in North America.

Warranty Item

Frame	10 Years
Parts	2 Years
Labor	1 Year

Cycle Boxer warrants that the equipment it manufactures is free from defects in materials and workmanship under normal use and services. The periods above are based on the date of purchase. During these periods, Cycle Boxer will repair or replace any defective part. Free labor is included on all parts that are not normally assembled or replaced by the customer within the labor period.

If within the time frames specified above, any part fails to operate properly, login to our website at www.lifespainfitness.com/support, click on "customer service" and complete the form to request assistance or call 801-973-9993 option 4 for a technical support Agent.

Cycle Boxer reserves the right to make changes and improvements to our products without incurring any obligations to similarly alter any product purchased. In order to insure our product warranty and to ensure the safe and efficient operation of your Cycle Boxer product, only authorized parts can be used. The warranty is void if any parts other than those provided by Cycle Boxer are used.

Exclusions and Limitations:

- This warranty does not apply to any defects caused by negligence, misuse, improper assembly, or maintenance, accident, or "act of God."
- This warranty does not apply to discoloration of paints or plastics.
- Cycle Boxer shall not be responsible for incidental or consequential damages.
- This warranty is non-transferable from the original owner.

by  LifeSpan

Technical Support LifeSpan
Fitness

785 W 1700 S Ste 1 Salt
Lake City, UT 84104

Phone: 801-973-9993

*Remove the Serial Number sticker
from Box A, and place here.*

Version 2.0