



Stretch Partner Warranty

The LifeSpan Stretch Partner comes with the following warranty:

Parts: 2 Years

Frame: 10 year for commercial use

10 years for residential use

Labor: 1 year

PCE Health and Fitness warrants that the equipment it manufactures is free from defects in material and workmanship under normal use and service.

If within the timeframe specified above, any part of the Stretch Partner fails to operate properly, contact your authorized PCE Health and Fitness Retailer to report the problem or contact PCE Health and Fitness at www.pcefitness.com or 801-973-9993.

PCE Health and Fitness reserves the right to make changes and improvements to our products without incurring any obligations to similarly alter any product purchased. In order to insure our product warranty and to ensure the safe and efficient operation of LifeSpan equipment, only authorized parts can be used. The product warranty is void if any parts, other than those provided by PCE Health and Fitness are used.

Exclusions and Limitations

- This Warranty does not apply to any defects caused by negligence, misuse, or improper assembly or maintenance.
- This warranty does not apply to discoloration of paint or plastics.
- PCE Health and Fitness will not be responsible for incidental or consequential damages.
- This warranty is non-transferable from the original owner.

Registration

You must register your LifeSpan product before a warranty claim can be processed and proof of purchase must be demonstrated at the time a claim is made. To complete your registration online, go to www.pcefitness.com and fill out the online registration or fill out the warranty card provided with your Stretch Partner and mail it today.

CONTENTS:

- Base
- Handlebar post
- Seat Frame
- Handlebars & Safety Straps
- Seat Bottom
- Seat Back
- Pedal Axle
- Pedals
- Seat Pivot Axle
- Instruction Bracket with User Instructions
- Plastic Covers
- Hardware Bag/Tools
 - a. 8 - 5mm Frame Screws
 - b. 8 - Bent Washers
 - c. 1 - 5mm Allen Wrench
 - d. 1 - 4mm Allen Wrench
 - e. 2 - 14mm Wrench's
 - f. 1 - Phillips Screwdriver
 - g. 1 - 14mm Lock Nut
 - h. 1 - Straight Washer

STEP 1: FRAME ASSEMBLY

- Insert the handlebar post bracket into the end of the base frame.
- Align the holes and using four, 5mm Allen head screws and 4 Bent Washers, hand tighten all four screws before securely tightening them with the Allen wrench provided.

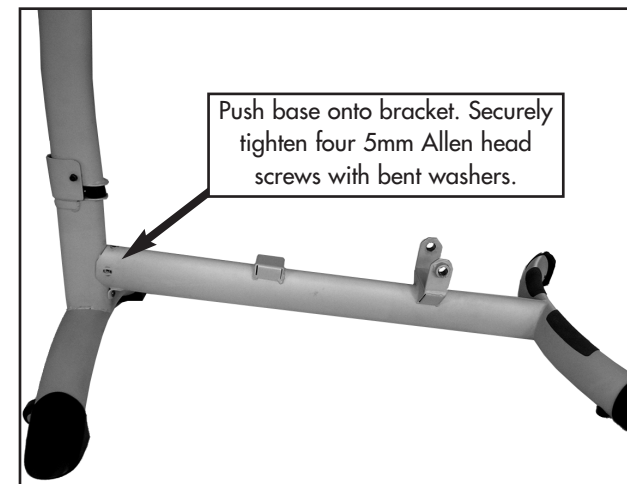

STEP 2: PLASTIC COVERS

- Remove the three Phillips head screws already in place on the plastic covers.
- Place the 2 plastic halves in place over the front joint and tighten down the 3 Phillips head screws.

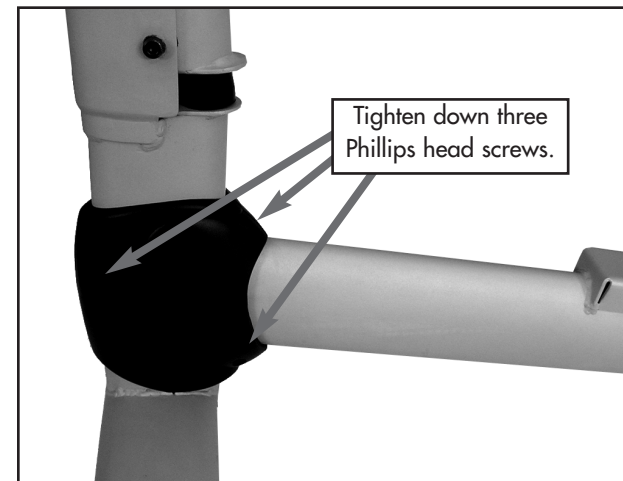

STEP 3: HANDLEBAR ASSEMBLY

- Put the Safety Strap around the handlebars and push the handlebar down onto the handlebar post.
- Locate the Instruction bracket and align the screw hole in the bracket with the screw hole in the front of the handlebar post. Hand tighten a 5mm Allen head screw with Bent Washer.
- Hand tighten the remaining 3 screws with bent washers and then securely tighten all four screws with the 5 mm Allen wrench provided.

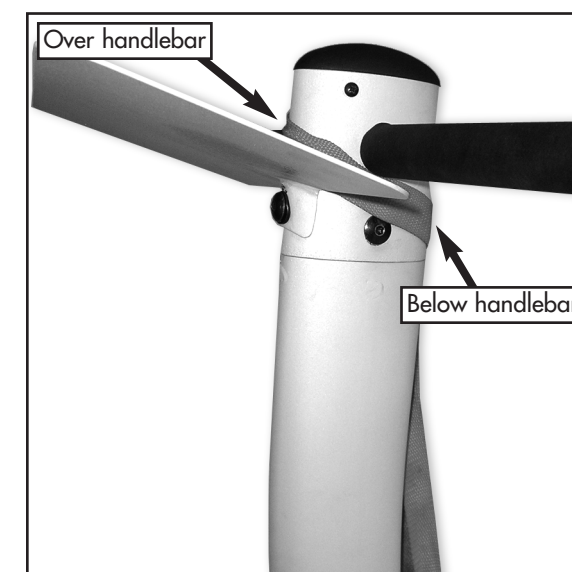

STEP 4: SEAT AXLE ASSEMBLY

- Locate the seat frame assembly and the seat pivot axle. Place the seat frame in place over the frame bracket and align the hole in the frame with the hole at the back of the seat frame.
- Once the holes are aligned, insert the axle into the bracket. **MAKE SURE THAT THE INDENT IN THE AXLE LINES UP WITH HOLE IN THE BRACKET AS SHOWN IN THE PHOTOGRAPH BELOW.**
- Using the 4mm Allen wrench provided, tighten the 2 set screws as shown in the picture below.

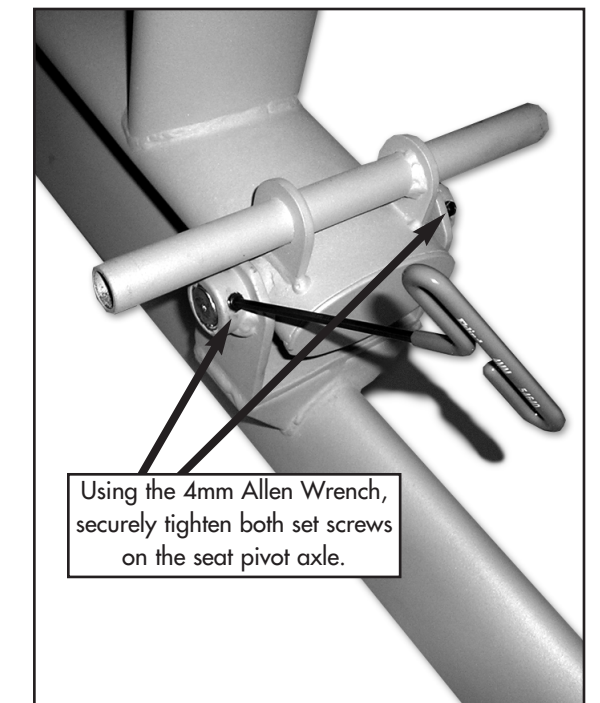
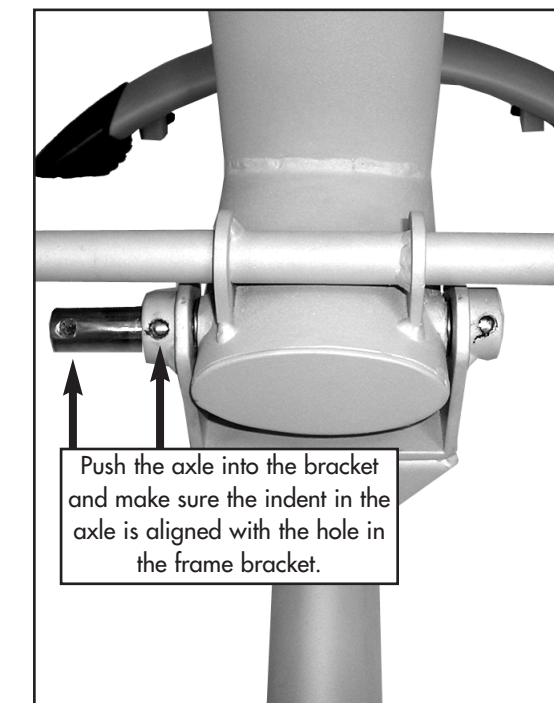

STEP 5: SEAT ASSEMBLY

- Locate the seat bottom, remove the four screws from the back of the seat bottom and securely tighten all four screws on the seat frame as shown in diagram below.
- Locate the seat back, remove the four screws from the seat back and securely tighten all four screws onto the seat frame bracket.

Note: Turn the seat bottom so that the front of the seat is flush with the oval seat tube. It should not overhang past the seat tube.



STEP 6: PEDAL AXLE/PEDALS

- Locate the pedal axle and the foot pedal. One of the ends on the axle already has a nut and washer installed. Over the opposite end, slide the left side pedal.
- Push the axle through the pedal axle shaft and push the right pedal over the end.
- Secure the pedal in place by using a washer and locknut. To tighten the nut you will need to use the 2 - 14mm socket wrenches provided. Put one wrench on each end of the axle and turn clockwise until tight.
- After the axle nuts are tightened, push the axle caps into the pedals.

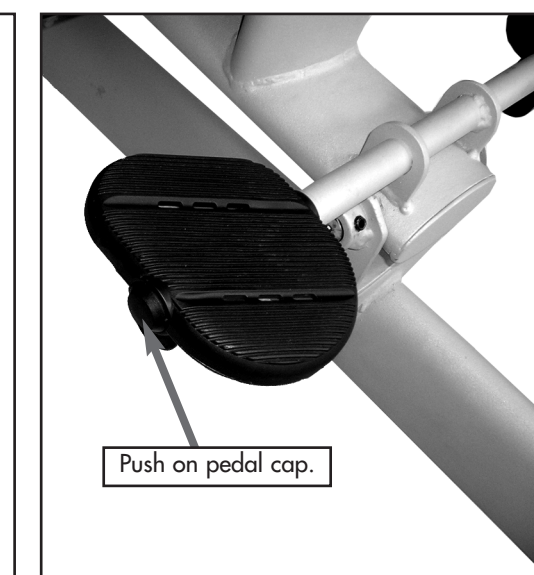
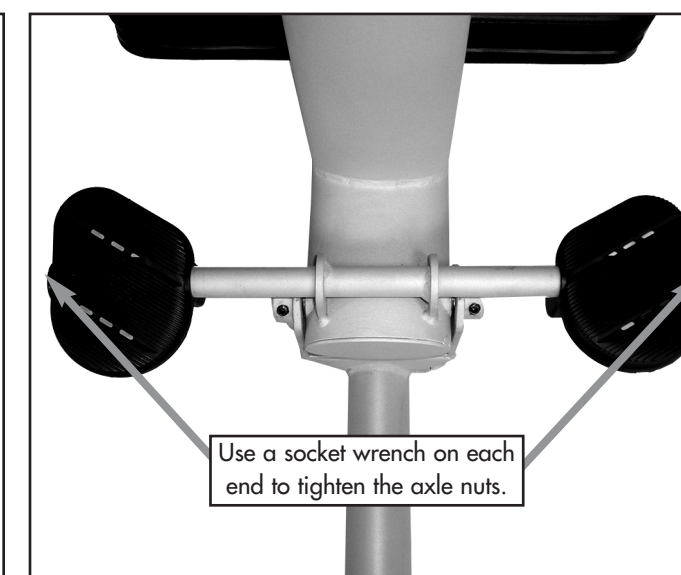
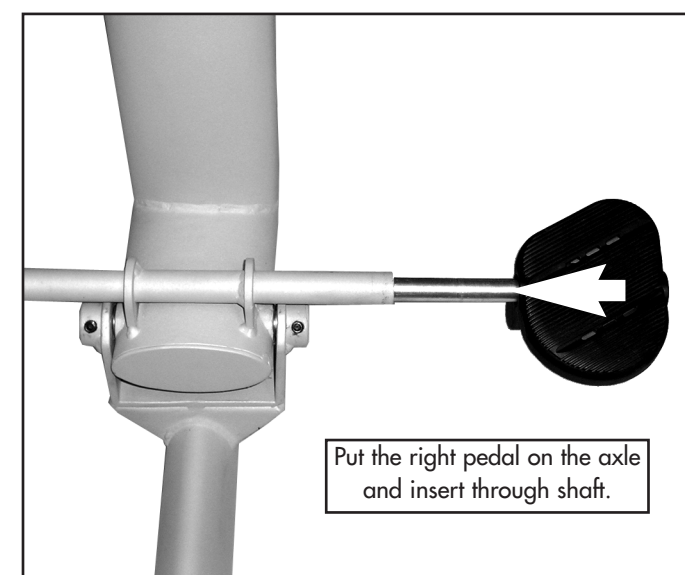

MONTHLY MAINTENANCE

- Check all screws in the frame and seat making sure that they are tight and secure.
- Check Safety Strap. If showing wear, call PCE Fitness for replacement.
- Check rubber bumper in the handlebar pivot. If any cracks or wear exists, replace the rubber bumper.
- Inspect the seat pivot axle and set screws ensuring that the axle is properly centered and the set screws are tight.