



Dero **Single Locker**

The Dero Single Locker™ offers bike parking for a single bicycle per unit, thus providing a narrower footprint when space is limited. This affordable bike locker is a perfect option for long-term bike parking applications, such as transit hubs and college campuses. Multiple locking options and most standard powder coat color options are available. Ships flat to save you money.

Dero Single Locker



FINISH OPTIONS

Galvanized



Powder Coat



LOCKING OPTIONS

U-lock/Padlock Handle

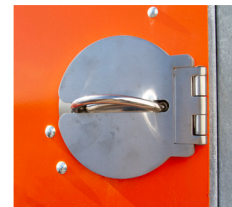

Keyed Lock



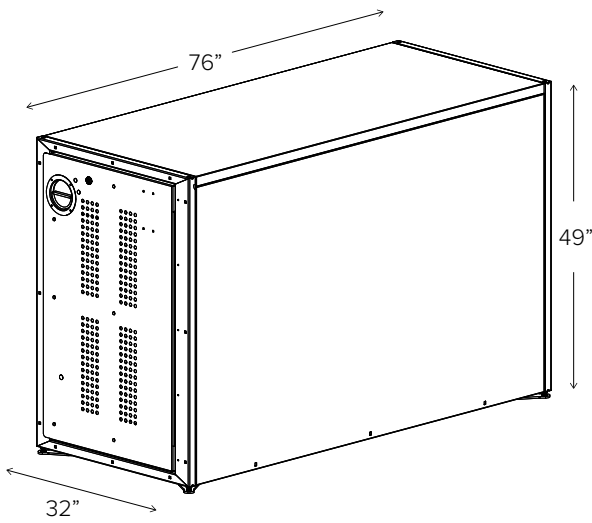

CAPACITY 1 Bike

MATERIALS

- Frame:** 1.50" x 3.00" x 14g tube
- Floor:** 18g plate
- Sides:** 18g plate
- Doors:** 16g plate
- Top:** 18g plate

FINISHES

- Galvanized**
An after fabrication hot dipped galvanized finish is our standard option. Pre-fabrication galvanizing is standard on panel components.
- Powder Coat**
Our powder coat finish assures a high level of adhesion and durability by following these steps:
 1. Sandblast
 2. Epoxy primer electrostatically applied
 3. Final thick TGIC polyester powder coat

LOAD DATA 40 psf snow, 90 mph wind exposure B, high seismic

SETBACKS Allow a 60" clearance from door face.

STANDARD

- Leveling feet
- Floor panel
- Ventilating window on doors
- Graffiti resistant
- UV resistant
- Numbered plates
- Gear hook
- Door closer

LOCKING SYSTEM

- Keyed Lock Only** (2 keys per lock)
- Padlock/U-Lock Handle**

Allow 60" clearance from door face.

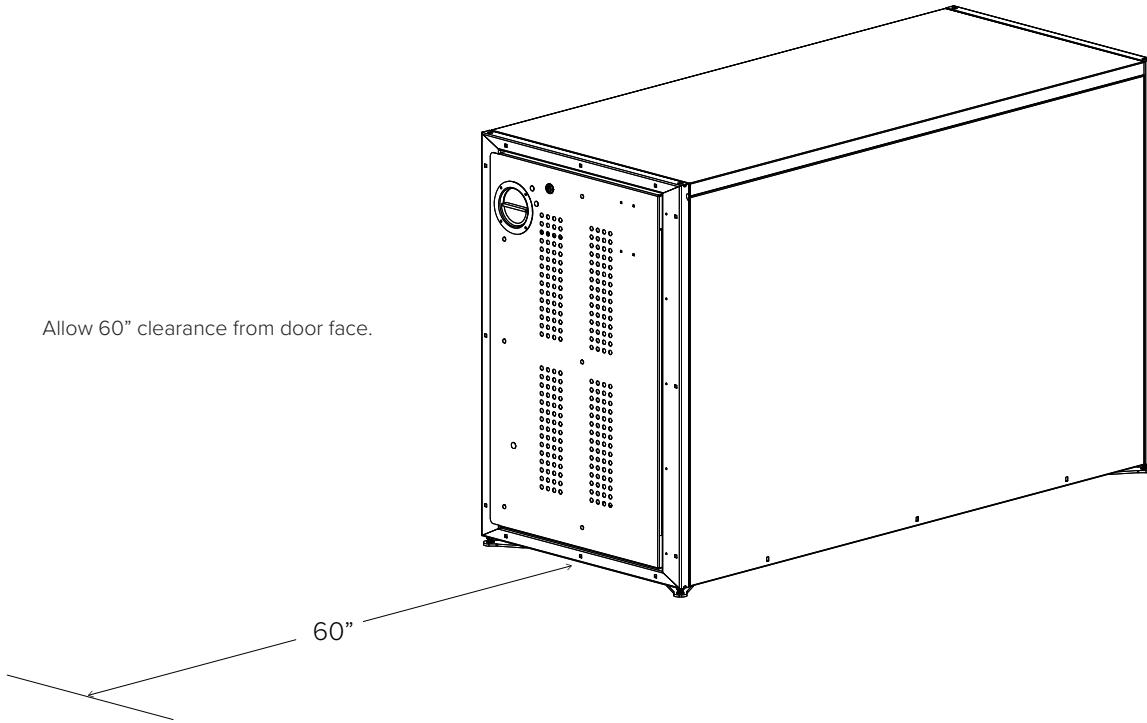

**TOOLS NEEDED**

Hammer drill with 3/8" masonry bit
Hammer
Bubble level
Tape measure
3/8", 7/16", 1/2", 9/16" wrenches
Socket wrench
3/8", 7/16", 1/2", 9/16" sockets
Power drill
3 Philips screw driver bit
Needle-nose pliers

RECOMMENDED BASE MATERIAL

Solid concrete is the best base material for installation. To ensure the proper anchors are shipped with your locker, ask your Dero representative which anchor is appropriate for your application. Be sure nothing is underneath the base material that could be damaged by drilling.

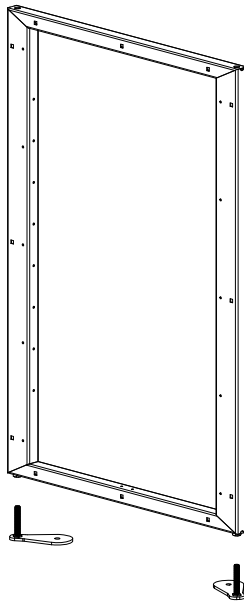
1

Thread (2) leveling feet into each door frame.

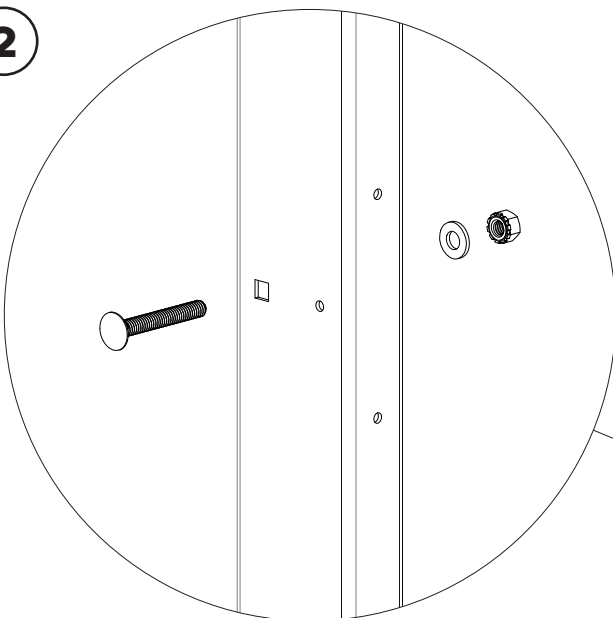
2

Attach (2) side panels to the (2) door frames with (12) 5/16" x 2.25" carriage bolts, washers, and locknuts. Omit the (4) bottom bolts for now. Leave locknuts finger-tight

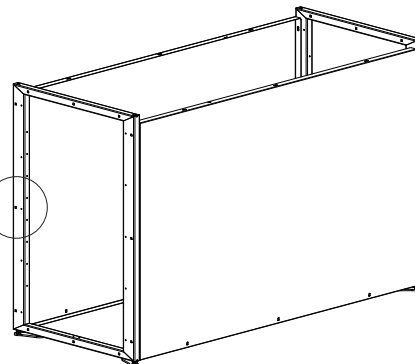

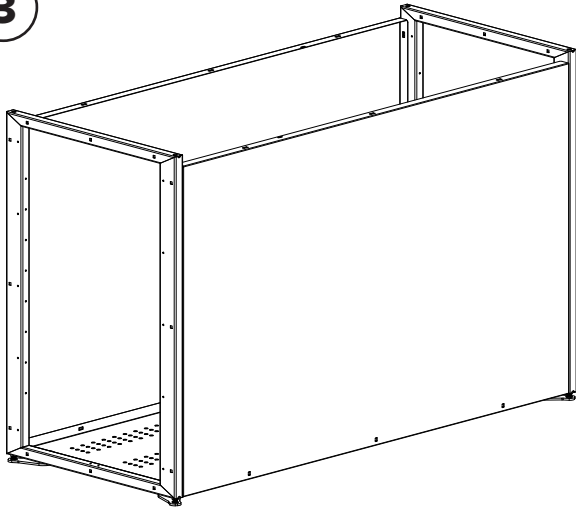
3

Place the floor panel in the locker and attach to the side panels with (6) 5/16" x .75" carriage bolts, washers, and locknuts. Attach to the door frames with (6) 5/16" x 2.25" carriage bolts, washers, and locknuts. Add the remaining (4) 5/16" x 2.25" carriage bolts, washers, and locknuts that attach the side panels to the door frames. Leave all locknuts finger-tight.

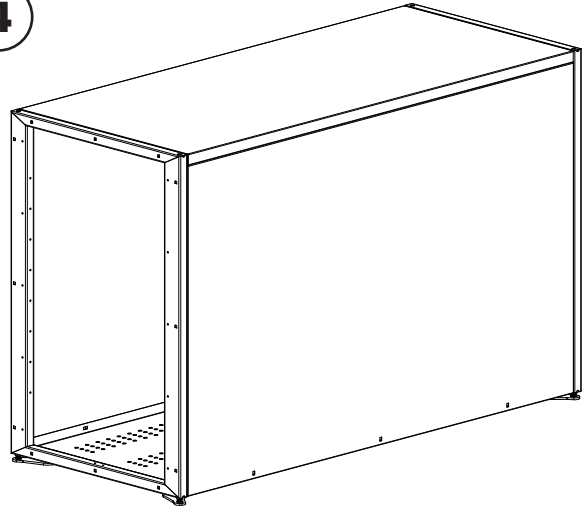
4

Place the roof panel on the locker and attach to the side panels with (6) 5/16" x .75" carriage bolts, washers, and locknuts. Attach to the door frames with (6) 5/16" x 2.25" carriage bolts, washers, and locknuts.

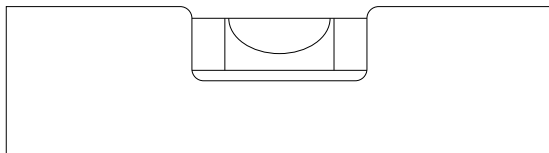
5

Check that the locker is level and square. Tighten all hardware.

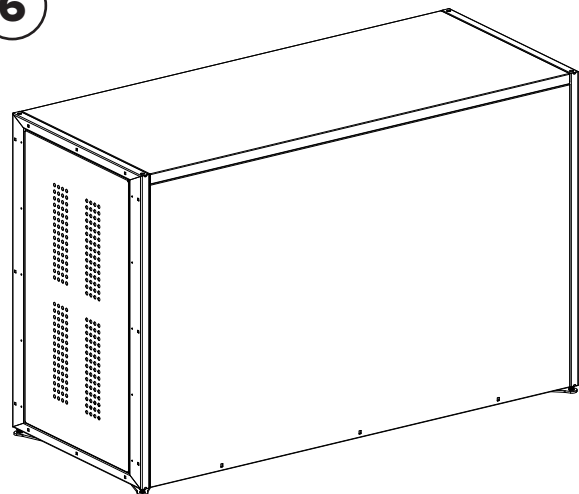
6

Attach the back panel to the rear door frame with (10) #12 x 3/4" self-drilling screws. Pilot holes are present but may be partially filled with zinc. Screwing is done from inside the locker.

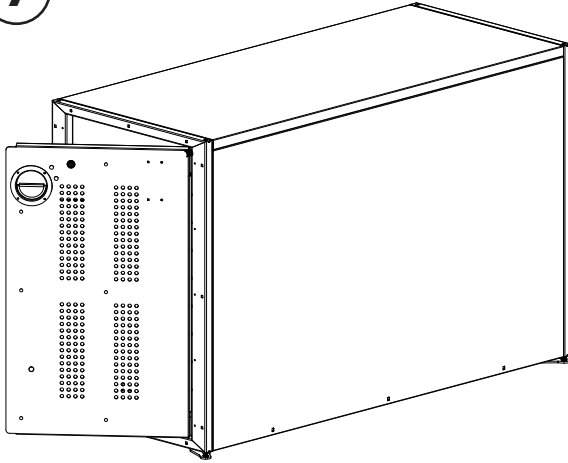
7

Attach the door assembly with (8) #12 x 3/4" self-drilling screws. Pilot holes are present but may be partially filled with zinc.

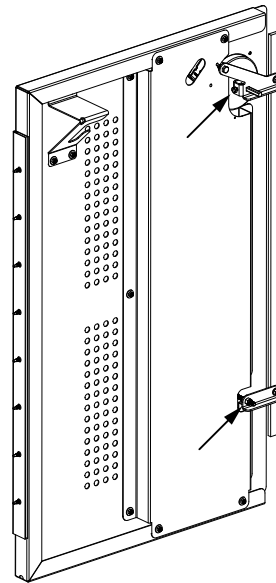
8

The gap between the door and latch bar may need to be adjusted to properly engage the door frame. This can be done via the 1/4" bolt that tightens against the handle spindle and the 5/16" nuts at the other pivot point.

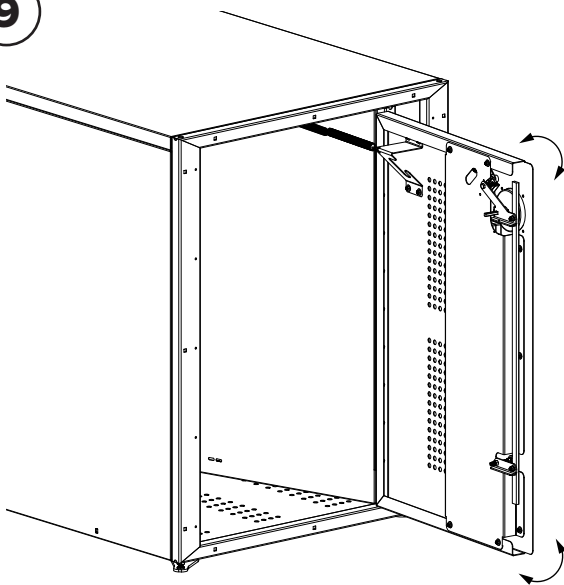
9

If any twist needs to be taken out of the door, loosen the #10 locknuts, set the door, and re-tighten.

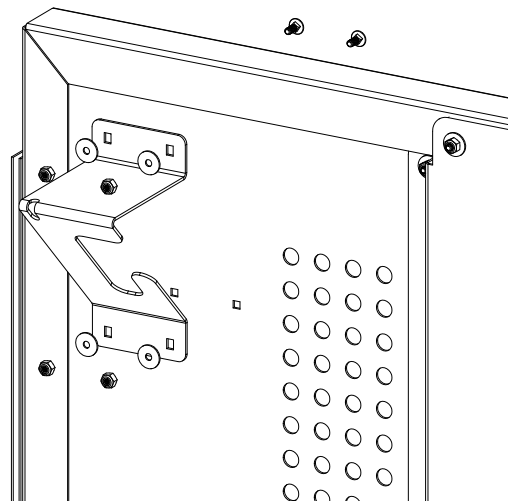
10

Attach the gear hook to the door back with (4) #10 x .50" carriage bolts, washers, and locknuts.

11

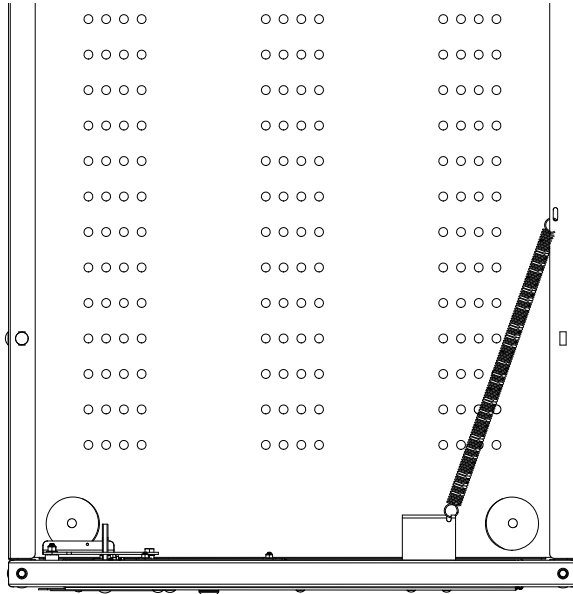

To install the door closer, attach the spring to the gear hook and to the side panel. A needle-nose pliers is helpful.

12

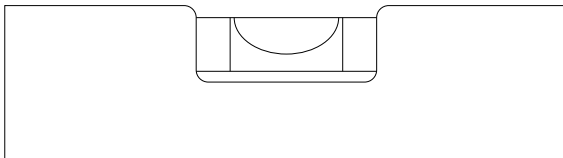

Move the locker into the desired location, level it with the leveling feet, and secure it to the ground with (4) 3/8 x 3" anchors. The leveling feet anchor holes should line up with the large holes in the locker floor.