



DERO
A PLAYCORE Company



Dero **Duplex**

The Dero Duplex doubles the capacity of your bike parking area with secure, efficient, and orderly storage. Its staggered design means that bikes enter and exit easily without entanglement. Sturdy trays with high sides keep bikes from slipping off while loading or unloading and also make the Duplex compatible with most standard u-locks.

Patent D768,545

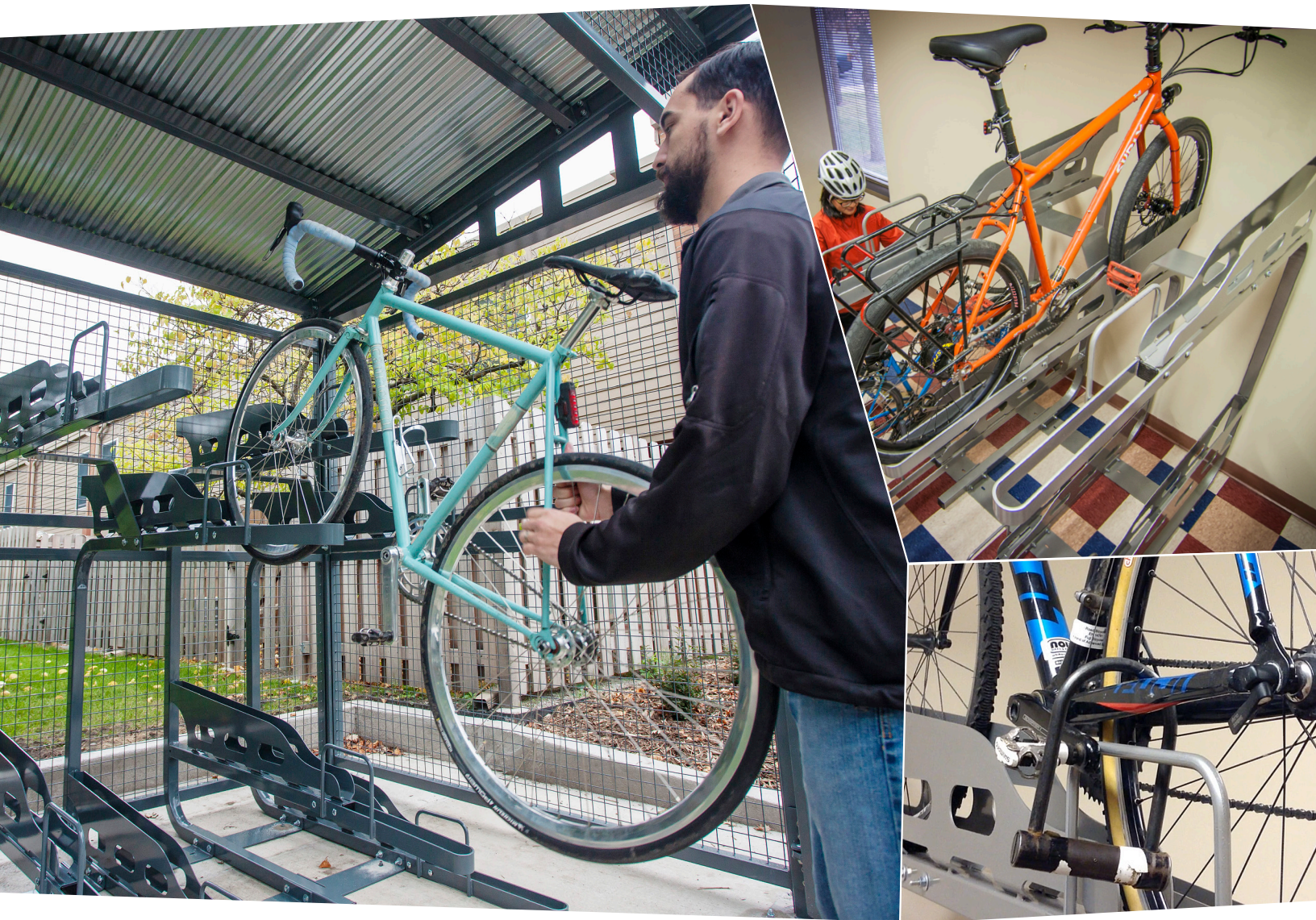

FINISH OPTIONS

Galvanized



Stainless



Powder Coat



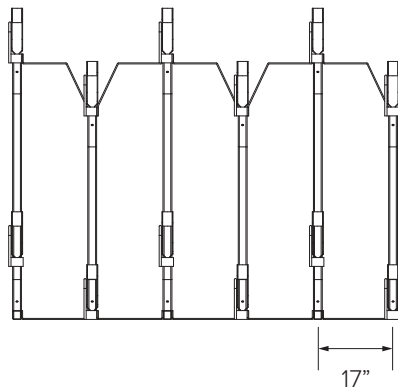
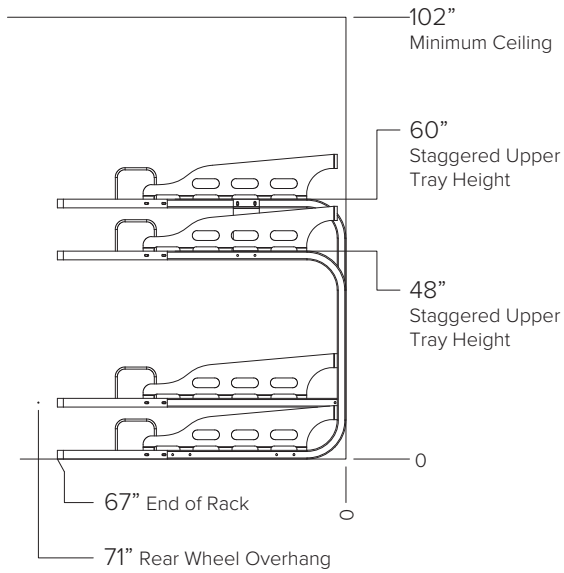

CAPACITY

Varies per configuration
Minimum 6 bike system required for stability

MATERIALS

Main frame tube: 2" 11g square tube
Connector plates: 1/4" plate
Bike trays: 11g plate

FINISHES

- Galvanized**
An after fabrication hot dipped galvanized finish is our standard option.
- Powder Coat**
Our powder coat finish assures a high level of adhesion and durability by following these steps:
1. Sandblast
2. Epoxy primer electrostatically applied
3. Final thick TGIC polyester powder coat
- Stainless**
304 grade stainless steel material with external surfaces polished to a satin finish. All surfaces passivated.

MOUNT OPTIONS

Surface only
Each connector plate accepts 3/8" wedge anchors.

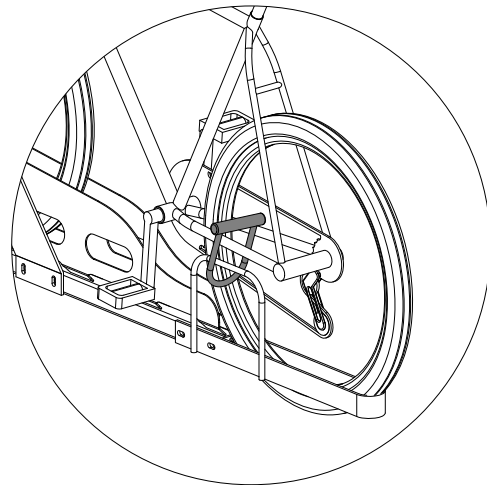

U-lock compatible

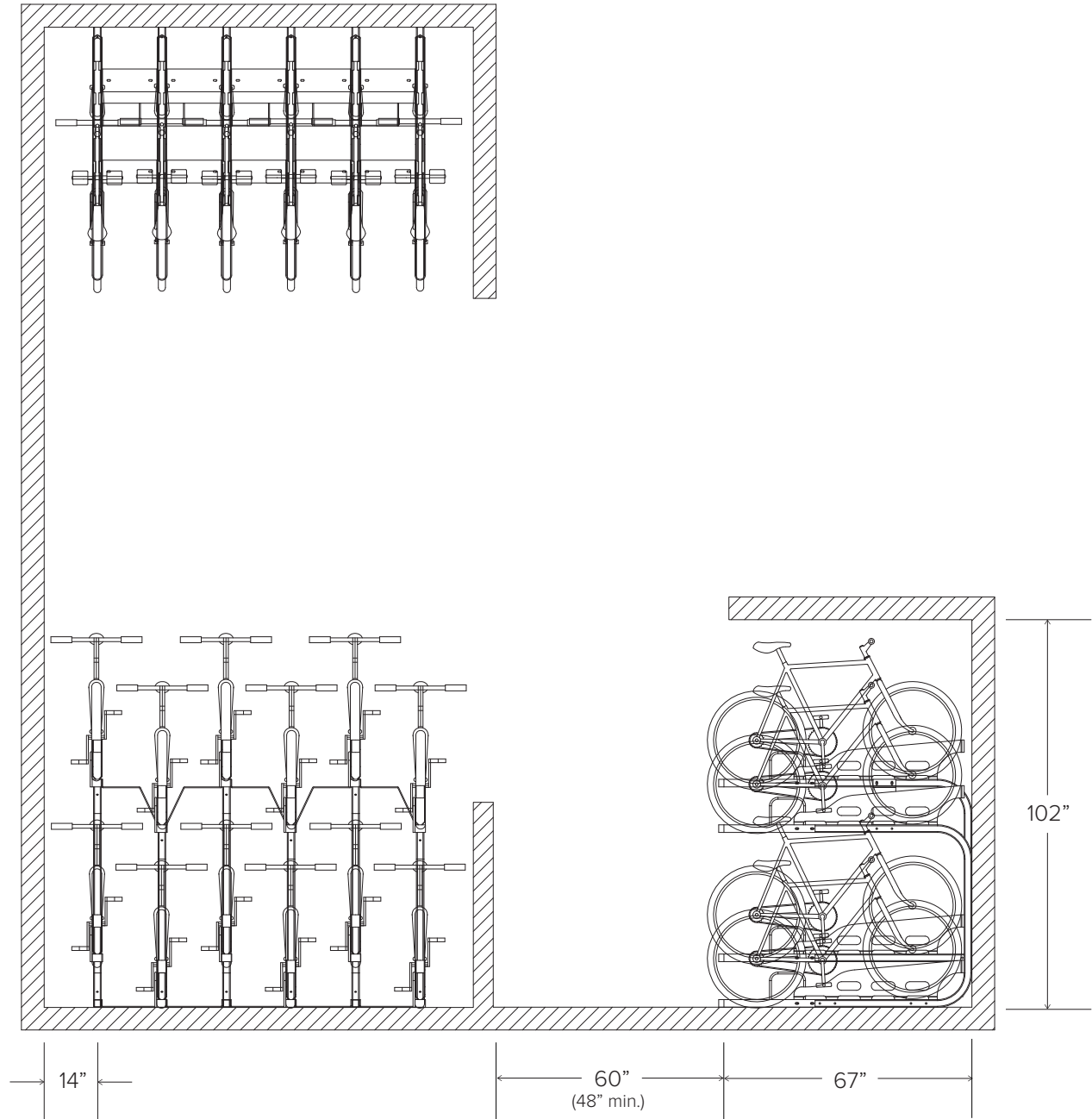



DERO
A PLAYCORE Company

Dero Duplex

Setbacks Double Sided

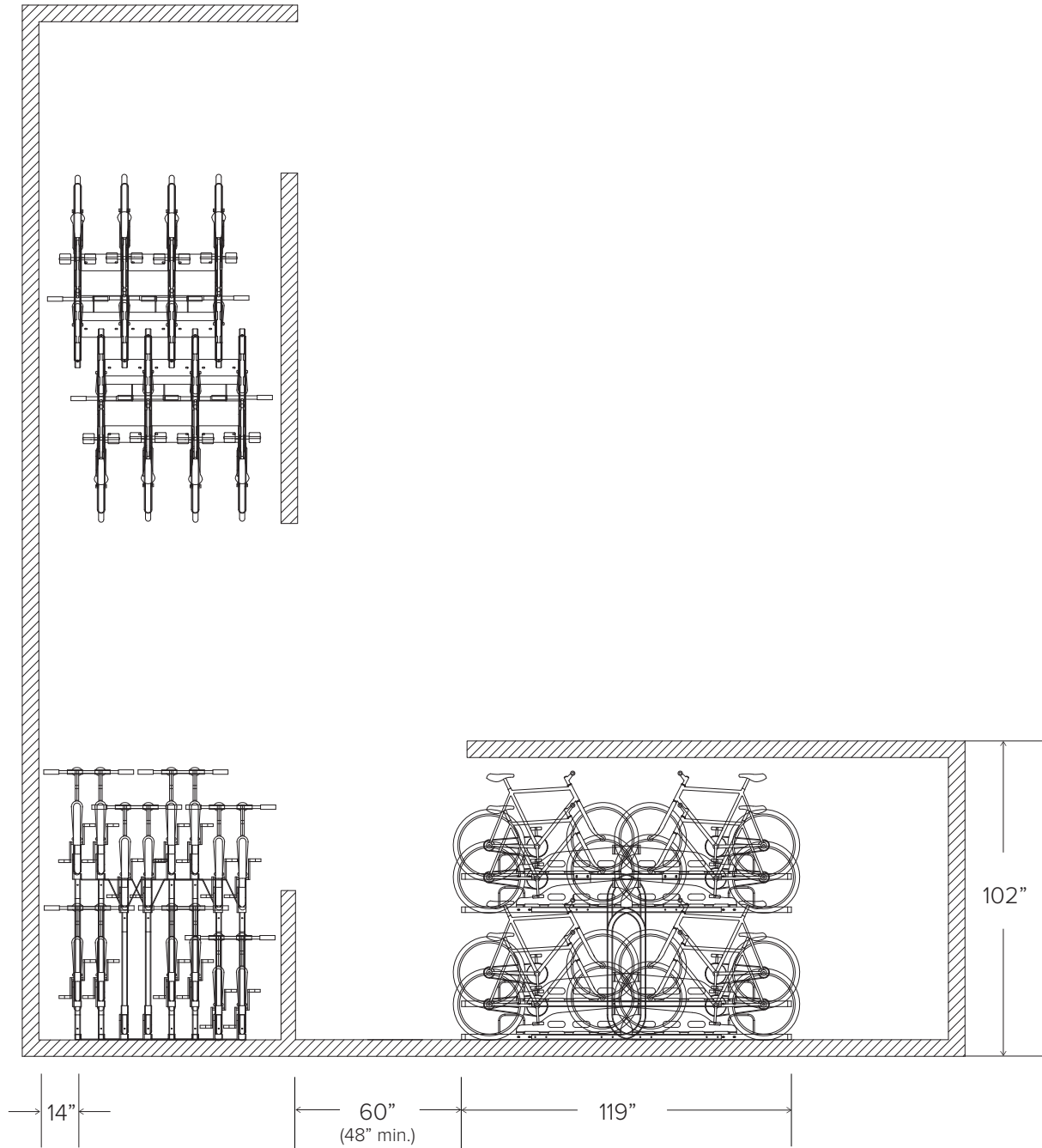

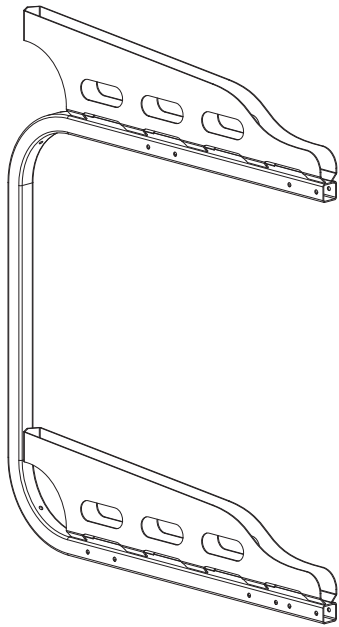

DUPLEX LOWER UNIT

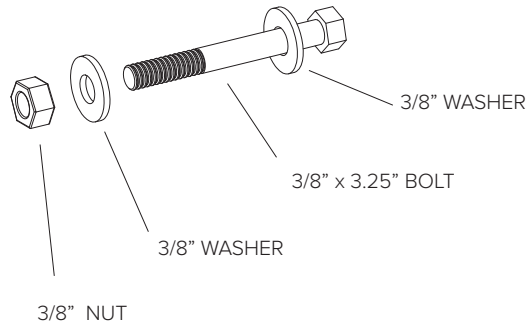

3/8" NUT

3/8" WASHER

3/8" x 3.25" BOLT

3/8" WASHER

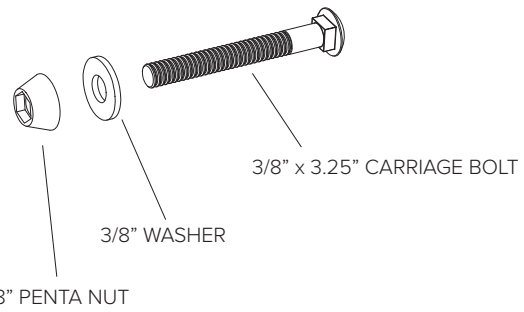

3/8" PENTA NUT

3/8" WASHER

3/8" x 3.25" CARRIAGE BOLT

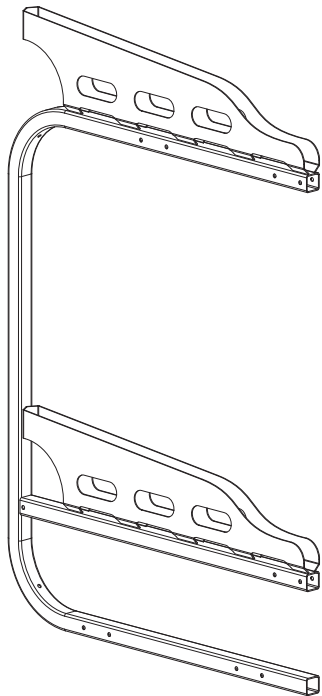

DUPLEX UPPER UNIT

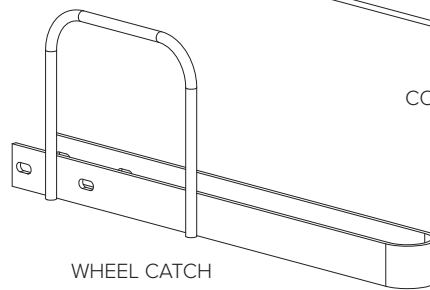

WHEEL CATCH

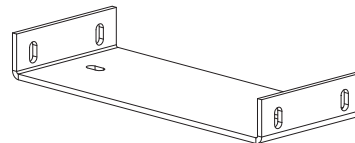

CONNECTOR BASE

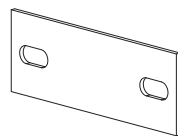

WHEEL CATCH SPACER

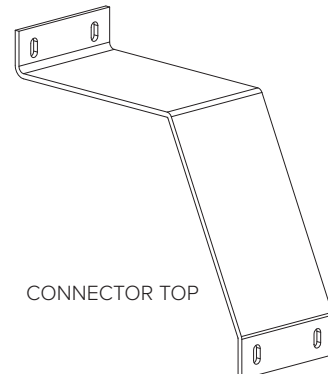

CONNECTOR TOP

1

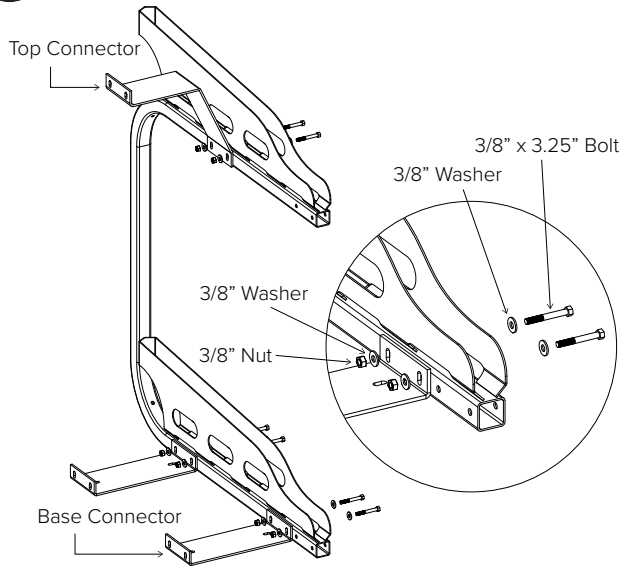

Place the first DUPLEX LOWER UNIT and attach CONNECTORS with hardware.

2

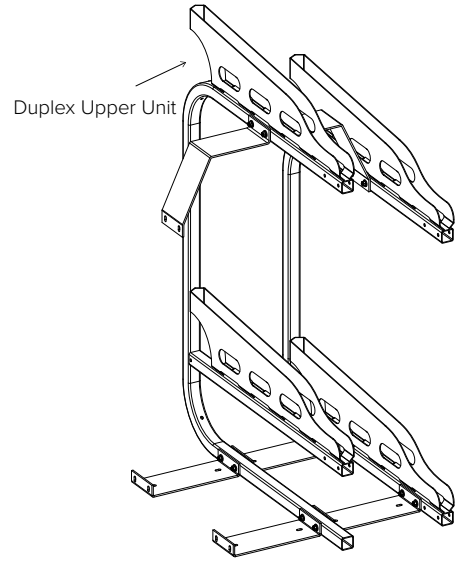

Drill the holes in accordance with the specifications shipped with the anchors. Make sure the holes are at least 3" away from any cracks in the base material.

3

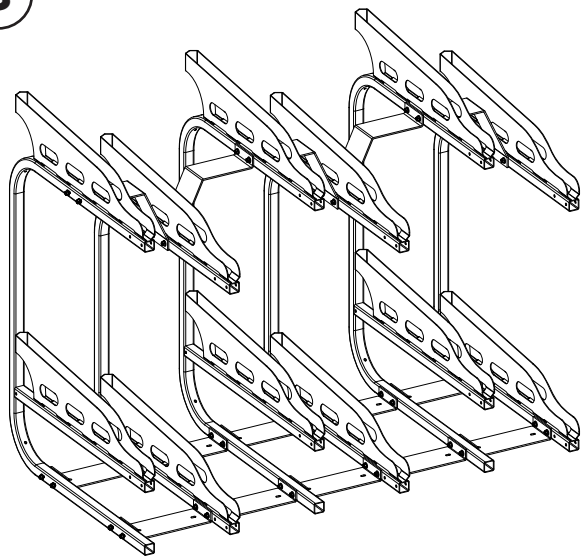

Continue repeating steps 1 and 2 as necessary.

4

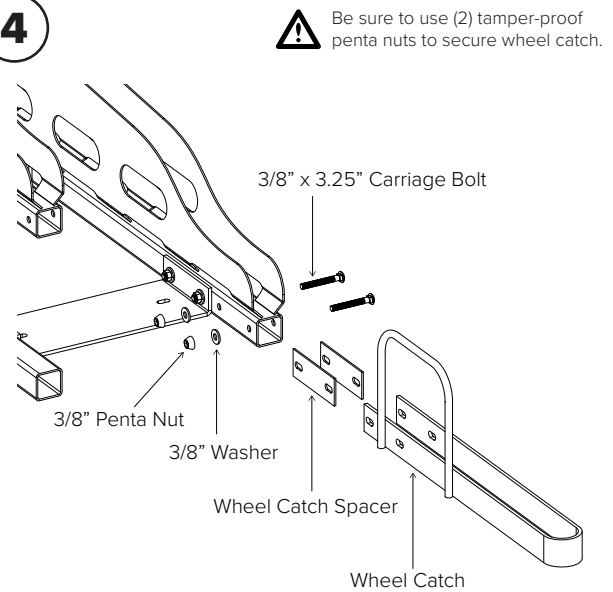

Place WHEEL CATCH and SPACERS and attach with hardware. Repeat for all trays.



5

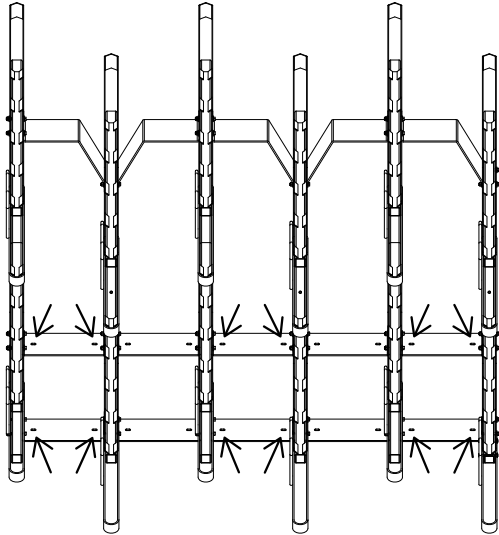

Secure the DUPLEX ASSEMBLY with 3/8" WEDGE ANCHORS. Secure at the first and last pair of bases and then every other pair of bases.

6

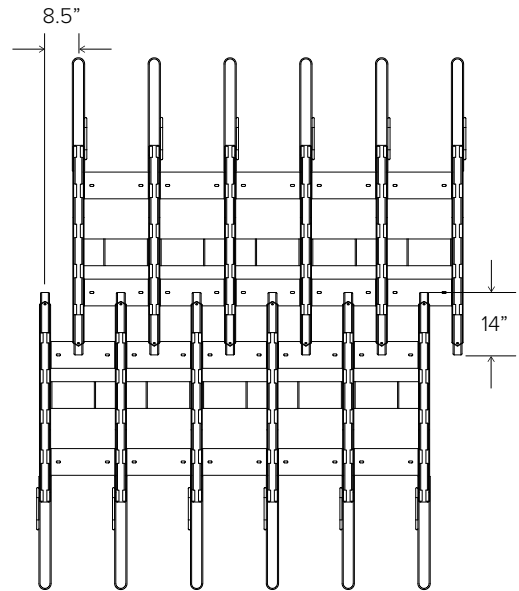

For double sided assemblies, simply place two single sided assemblies back to back with a 14" overlap.