



DERO
A PLAYCORE Company



350 Series Bike Locker

Bike lockers provide protection from less savory elements, whether environmental or human. Model options include storage for one or two bikes, stacked models, and rectangular or wedge shaped. The 301 model comes complete, no assembly required.

350 Series Bike Locker



LEED Credits

The use of bike lockers at your facility provides several advantages. By offering your bicycle riders a covered and secure place to park their bikes you can earn LEED credits for your building and place yourself at the forefront of environmentally responsible construction.



COLOR OPTIONS

350 Series Color Options

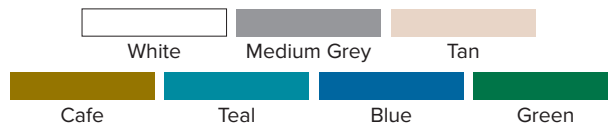



Models 351, 352

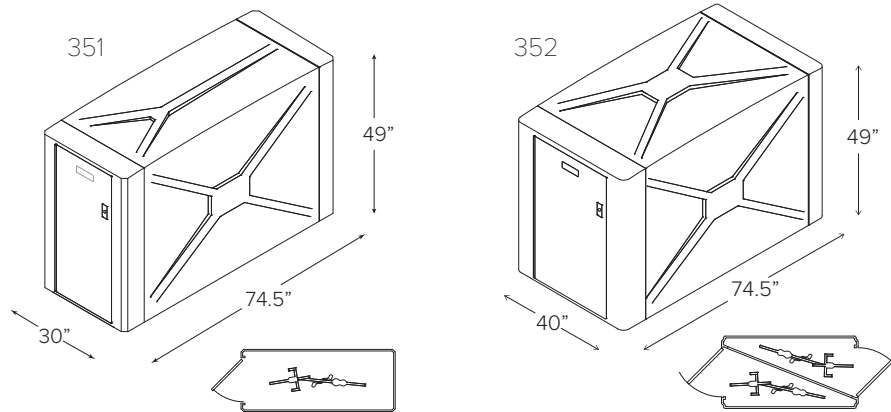

Structure and Finish

- 1 or 2 bike capacity
- Modular molded fiberglass plastic composite
- UV and graffiti resistant
- Comes in choice of seven colors
- Comes standard with T-handle lock system
- All stainless steel hardware
- Gear Hooks (2 per locker)
- Airflow vents
- Engraved locker numbers (Starting at 1 unless otherwise noted)
- Ships flat, some assembly required
- Fiberglass reinforced plastic construction is highly resistant to impact and scratching
- Finish never needs painting, will not rust or corrode, and is extremely resistant to stains
- Standard locking mechanism is completely internal and resists tampering



TOOLS NEEDED

- Claw hammer
- 7/16" wrench open end
- 7/16" socket (deep style) & ratchet
- 1/2" wrench open end
- 1/2" socket (deep style) & ratchet
- 3/8" electric drill
- 3/8" electric rotary hammer drill
- 1/4" drill bit
- 3/8 hammer drill bit
- Tape measure – minimum 10'
- Extension cord long enough to reach power source & move around locker site
- Generator, or other power source
- Safety glasses and any other equipment specified by the tool manufacturer

Choose location which allows a minimum 4' distance between door face and any obstruction to allow bicycle to maneuver into locker and the door to swing open without hitting high spots such as concrete or asphalt raised by roots. If desired, for grouping of units, chalk a line for straight edge with which to work. A preferred site would be concrete although asphalt can be used. Site should be flat although it does not necessarily have to be level.

STEP 1: FRAMES AND WALLS

If your locker doors are pre-numbered you will want to verify they are installed in a sequential order. Place the door frame, with the door open, and end cap approximately 60" apart measuring from flange to flange of both. This will let you slide the walls into position on both the door frame and end cap at the same time.

Once the walls are in place, insert 1/4" x 1" hex head bolts and washers through the predrilled holes in the walls and into the holes in the door frame and end cap. Tighten down the bolts with the nuts, around the door frame, end cap and walls. Only hand tighten the bolts down at this time. This will hold the parts in place in order to do the next steps.

If you are grouping two or more lockers, proceed to Step 2. If not, proceed to Step 3.

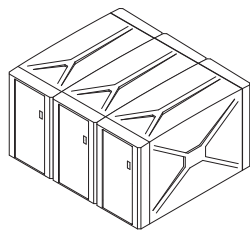

Proceed to Step 2

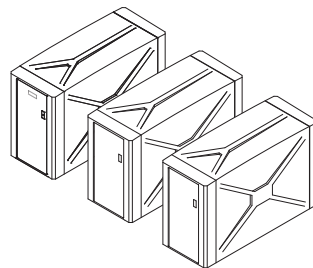

Proceed to Step 3



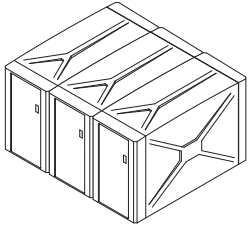

STEP 2: GROUPED UNITS

If you are joining two or more lockers in a group you will now need to follow these instructions. First, install the L-Brackets to the flange of the next door frame using 1/4" x 1" hex head bolts, washers and nuts.

Put the next door frame and L-Bracket beside the existing door frame that was just assembled. Making sure both door frames line up (front to back, top to bottom), drill and bolt the opposite side of the bracket onto the finished side of the wall.

Once the L-Brackets are installed and **HAND TIGHTENED** to the wall, follow Step 1 to attach the second end cap and wall, using the hardware provided.



Please note that there is a difference between the L-Brackets for the "Top" and the "Frame". There will be 3 L-Brackets per interior wall. They will be labeled as shown.

STEP 3: LOCKER TOP

*** Make sure all the walls are assembled before moving onto this step.**

Using two or more people, take the top and place it between the door frame and end cap. Line up all bolt holes for the top, walls, door frame and end cap. Place 1/4" x 1" hex head bolts through pre-drilled holes and attach washer and nut.

Outer surfaces should be even where all parts come together. **Make sure they are even.** You can now tighten bolts installed in Steps 1, 2 and 3.

***When grouping units, the first locker top will be installed per the above instructions. Each additional top will be installed slightly different.** After the next top is tightened down to the door frames, mount the L-Bracket to the top where you would connect the top to the wall, using the 1/4" x 1" hex head bolts through pre-drilled holes and attach washer and nut.

Tighten down L-Bracket to top, and then drill holes through L-Bracket and wall. Using the 1/4" x 1" hex head bolts, tighten the L-Bracket to the wall. Repeat for all add-on units.

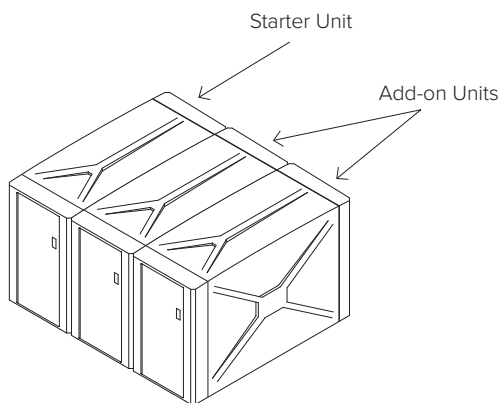

"Y" pattern on top should be as shown.

STEP 4: ANCHORING TO THE GROUND

After the lockers are assembled they will need to be anchored to the ground at all four corners. Included are adjustable anchor brackets to level the units.

Once the locker is in place, loosen the nuts on the anchor bracket. This requires a 7/16" end wrench or socket. After nuts are loosened, slide anchor bracket down, and at the same time using a flat bar, bring locker(s) into a level position and tighten the nuts. Do this for all four corners. This is usually a very slight adjustment. The locker, if necessary, can be raised up to 1".

After locker is level, drill a 3/8" x 3" deep hole through the bracket and into the mounting surface. *Hint: Place a piece of tape around the drill bit 3" from the tip of the bit. Stop drilling once the tape is no longer visible.*

Insert the anchor into the hole and tighten using 1/2" wrench or socket.



Loosen and level



Drill through ground



Place anchor and tighten

If you are assembling and installing any more units, simply repeat Steps 1-4.

TOOLS NEEDED

- Claw hammer
- 7/16" wrench open end
- 7/16" socket (deep style) & ratchet
- 1/2" wrench open end
- 1/2" socket (deep style) & ratchet
- 3/8" electric drill
- 3/8" electric rotary hammer drill
- 1/4" drill bit
- 3/8 hammer drill bit
- Tape measure – minimum 10'
- Extension cord long enough to reach power source & move around locker site
- Generator, or other power source
- Safety glasses and any other equipment specified by the tool manufacturer

Choose location which allows a minimum 4' distance between door face and any obstruction to allow bicycle to maneuver into locker and the door to swing open without hitting high spots such as concrete or asphalt raised by roots. If desired, for grouping of units, chalk a line for straight edge with which to work. A preferred site would be concrete although asphalt can be used. Site should be flat although it does not necessarily have to be level.

STEP 1: FRAMES AND WALLS

If your locker doors are pre-numbered you will want to verify they are installed in a sequential order. Place the door frame, with the door open, and end cap approximately 60" apart measuring from flange to flange of both. This will let you slide the walls into position on both the door frame and end cap at the same time.

Once the walls are in place, insert 1/4" x 1" hex head bolts and washers through the predrilled holes in the walls and into the holes in the door frames. Tighten down the bolts with the nuts, around the door frames and walls. Only hand tighten the bolts down at this time. This will hold the parts in place in order to do the next steps.

If you are grouping two or more lockers, proceed to Step 2. If not, proceed to Step 3.

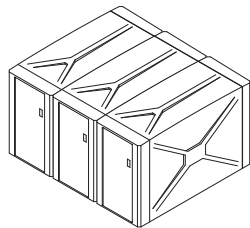

Proceed to Step 2

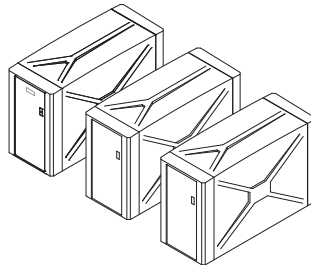

Proceed to Step 3



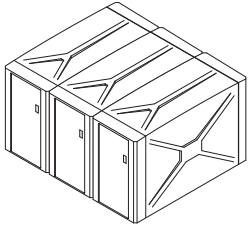

STEP 2: GROUPED UNITS

If you are joining two or more lockers in a group you will now need to follow these instructions. First, install the L-Brackets to the flange of the next door frame using 1/4" x 1" hex head bolts, washers and nuts.

Put the next door frame and L-Bracket beside the existing door frame that was just assembled. Making sure both door frames line up (front to back, top to bottom), drill and bolt the opposite side of the bracket onto the finished side of the wall.

Once the L-Brackets are installed and **HAND TIGHTENED** to the wall, follow Step 1 to attach the second end cap and wall, using the hardware provided.



Please note that there is a difference between the L-Brackets for the "Top" and the "Frame". There will be 3 L-Brackets per interior wall. They will be labeled as shown.

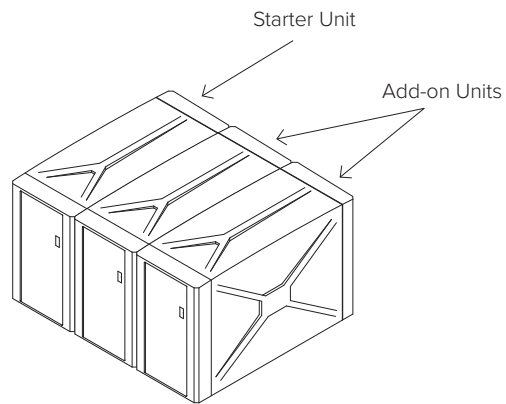
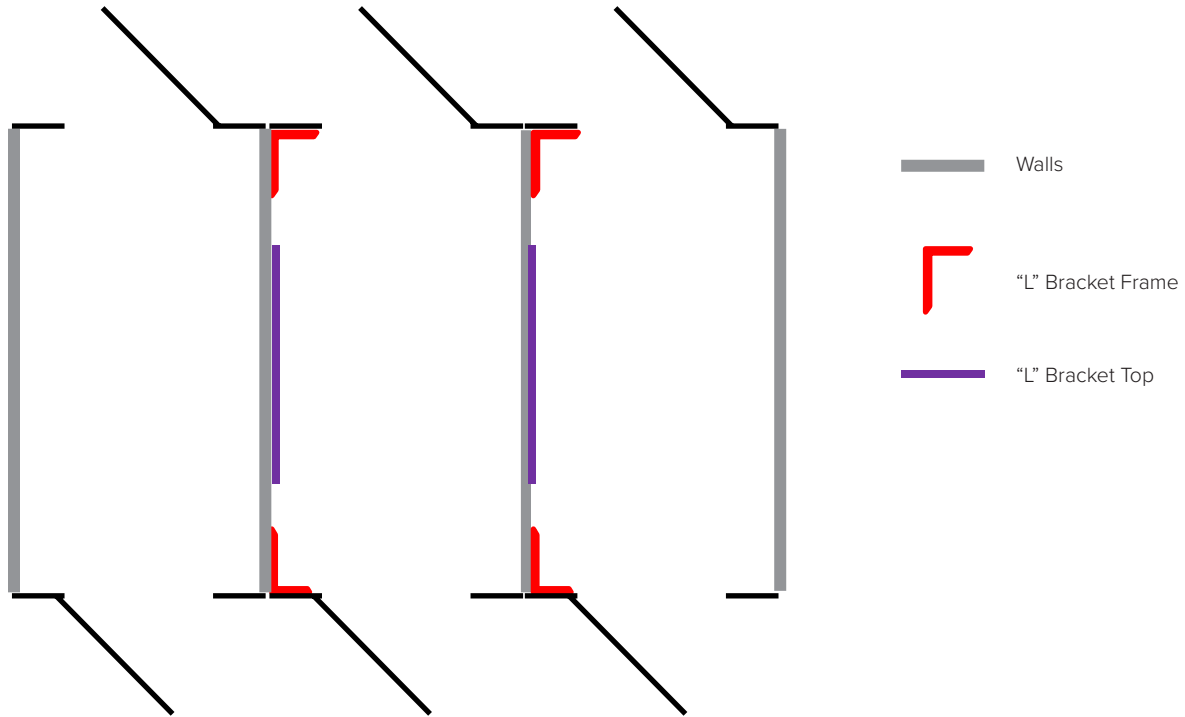

STEP 3: LOCKER TOP

*** Make sure all the walls are assembled before moving onto this step.**

Using two or more people, take the top and place it between the door frame and end cap. Line up all bolt holes for the top, walls, door frame and end cap. Place 1/4" x 1" hex head bolts through pre-drilled holes and attach washer and nut.

Outer surfaces should be even where all parts come together. **Make sure they are even.** You can now tighten bolts installed in Steps 1, 2 and 3.

***When grouping units, the first locker top will be installed per the above instructions. Each additional top will be installed slightly different.** After the next top is tightened down to the door frames, mount the L-Bracket to the top where you would connect the top to the wall, using the 1/4" x 1" hex head bolts through pre-drilled holes and attach washer and nut.

Tighten down L-Bracket to top, and then drill holes through L-Bracket and wall. Using the 1/4" x 1" hex head bolts, tighten the L-Bracket to the wall. Repeat for all add-on units.

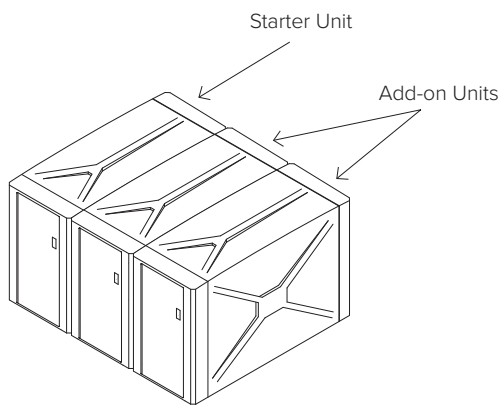

"Y" pattern on top should be as shown.

STEP 4: ANCHORING TO THE GROUND

After the lockers are assembled they will need to be anchored to the ground at all four corners. Included are adjustable anchor brackets to level the units.

Once the locker is in place, loosen the nuts on the anchor bracket. This requires a 7/16" end wrench or socket. After nuts are loosened, slide anchor bracket down, and at the same time using a flat bar, bring locker(s) into a level position and tighten the nuts. Do this for all four corners. This is usually a very slight adjustment. The locker, if necessary, can be raised up to 1".

After locker is level, drill a 3/8" x 3" deep hole through the bracket and into the mounting surface. *Hint: Place a piece of tape around the drill bit 3" from the tip of the bit. Stop drilling once the tape is no longer visible.*

Insert the anchor into the hole and tighten using 1/2" wrench or socket.



Loosen and level



Drill through ground



Place anchor and tighten

If you are assembling and installing any more units, simply repeat Steps 1-4.

STEP 5: INSTALLING DIAGONAL

To install the interior diagonal slide the wall through one of the door frames as shown. (This angle is the easiest way to install the diagonal.) The diagonal wall should be installed onto the left side of the door frame (behind hinge) and must be attached to the angled lip of the door frame.

Once in place, clamp diagonal to the angled lip to hold it place while drilling.

Once clamped, drill two 1/4" holes, 8" from the top and 8" from the bottom of the locker through both the diagonal wall, and the angled lip of the door frame.

Bolt the door frame and diagonal together with 1/4" x 1 1/4" hex head bolts, washers and nuts.

