

ActionFit Traditional

UP265 HURDLE

Parts List		
DESCRIPTION	QTY	PART NUMBER
HURDLE	3	304545
HARDWARE COMPLETE	1	403974
USAGE/WARNING LABEL	1	403867*

Unless Otherwise Specified, All Units of Measure are Each

**Items listed below Hardware Complete line are included with Hardware Complete Number*

Warning: During Installation, Hardware And Small Parts Are Choking Hazards For Young Children. Store Unused Parts Appropriately Until Assembly Is Completed. Once Assembly Is Completed, Remove Any Unused Parts From The Play Environment And Dispose/Save Them In A Secure Location. Any bolt end protruding more than two full threads beyond the face of the nut causes risk of clothing entanglement.

Promptly cut-off flush, file smooth, and treat to prevent corrosion.

Note: Peen Tee-Nuts and Flatwashers to match radius of pipe after assembly is complete.

Note: Loctite (supplied by others) should be used on any non-patch hardware.

SPECIFICATIONS:

U-PIPES: Shall be 1-5/8" O.D. galvanized steel tube with a baked on polyester powder coat finish.

HARDWARE: All nuts, bolts, screws, inserts, and lockwashers used in the assembly of all play equipment, shall be stainless steel, yellow dichromate plated steel, blue-coat plated steel, mechanically galvanized or powder coated/yellow dichromate plated steel. All primary fasteners shall be 300 series stainless steel. Fasteners with yellow dichromate treatment have an electro deposited, 99.9% pure zinc substrate applied from a specially formulated solution sealed with a yellow dichromate top coat designed to work in conjunction with the zinc plating. Yellow dichromate has a 320% longer life to white corrosion and 275% longer to red corrosion than does hot-dip galvanizing.

INSTALLATION INSTRUCTIONS:

NOTE: Read installation instructions thoroughly before starting assembly. Pour concrete only after final assembly is completed. Bracing material is required during assembly.

NOTE: Assembly and leveling times will be greatly reduced if a transit is used to set location and depth of ground holes.

NOTE: Place a brick or equivalent at the bottom of ground holes (where shown), to provide a solid foundation. Allow for this in the hole depth.

STEP 1: Dig holes according to Plan View. **NOTE:** Due to extremes in weather and soil conditions, hole size may have to be increased to meet local conditions.

STEP 2: Level Hurdles using sway bracing.

NOTE: It is recommended that 2" x 4" braces be cut the same lengths as the distance between each set of Hurdles noted on Assembly Drawing. Use the braces between bars to hold distance until concrete is poured and cured.

STEP 3: Pour concrete according to Detail A.

ActionFit Traditional

UP265 HURDLE

MAINTENANCE PROCEDURE:

Periodically check hardware for tightness, and tighten as necessary, also check if the entrapments and protrusions still satisfactory. Always check all metal parts for paint peeling, corrosion and touch up if necessary. Check all parts for cracks, breakage or wear, and immediately put equipment out of service until any faulty parts found are repaired or replaced. Check periodically resilient surfacing for appropriate depth and remove extraneous materials that could cause injury, infection, or disease. Maintain detailed installation, inspection, maintenance, and repair records for each public-use playground equipment.

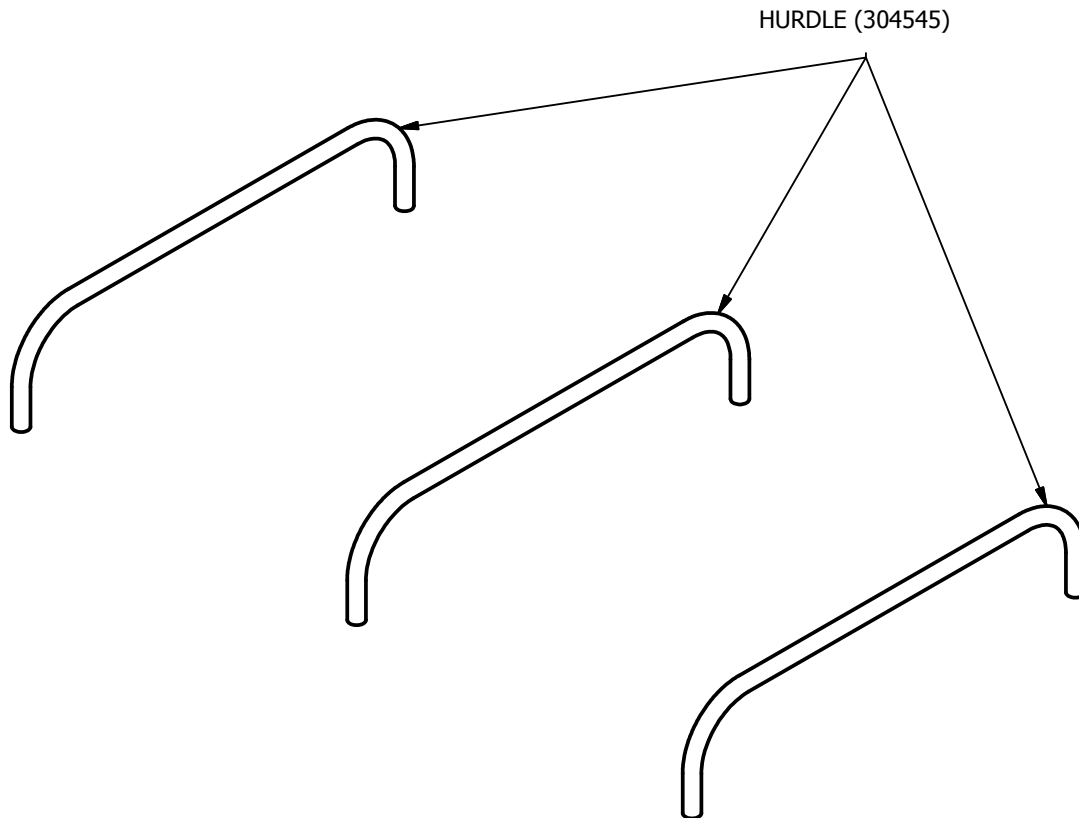

NOTE:
MINIMUM OF ONE USAGE/WARNING LABEL
SIGN POST (UP197) MUST BE USED WITH EACH
HURDLE STATION. SEE SIGN POST
INSTALLATION SHEET FOR INSTALLATION DETAILS.

**SIGN POST MUST BE OUTSIDE MAXIMUM SPACE IN WHICH
THE USER AND EXERCISE EQUIPMENT COMPONENTS
TRAVERSE WHEN THE EQUIPMENT IS OPERATED.**

FINISHED ASSEMBLY

 = INSTALLATION DETAIL

Issued/Revised: 9/30/16



800.458.5872

www.actionfitoutdoors.com

ActionFit Traditional

UP265 HURDLE

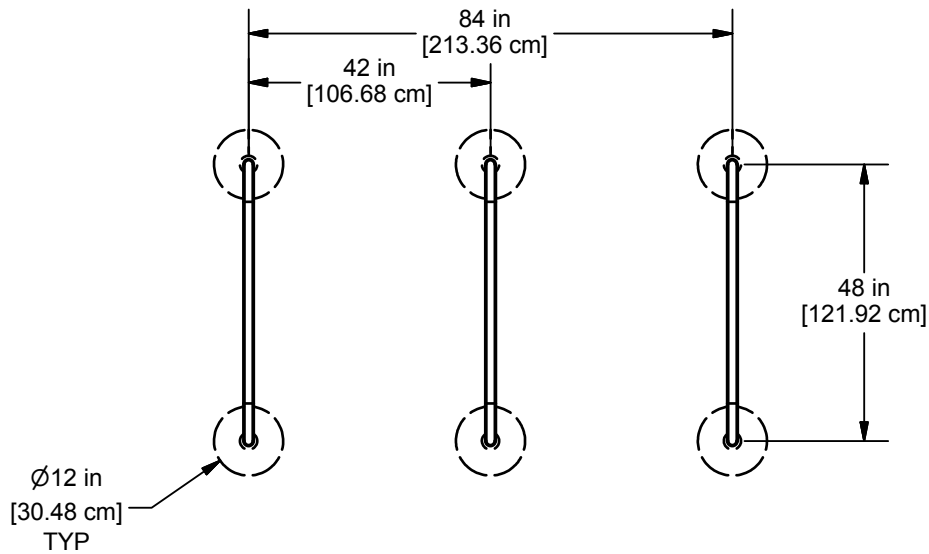

CONCRETE REQUIRED:
0.30 CUBIC YARDS
[0.24 CUBIC METERS]

PLAN VIEW

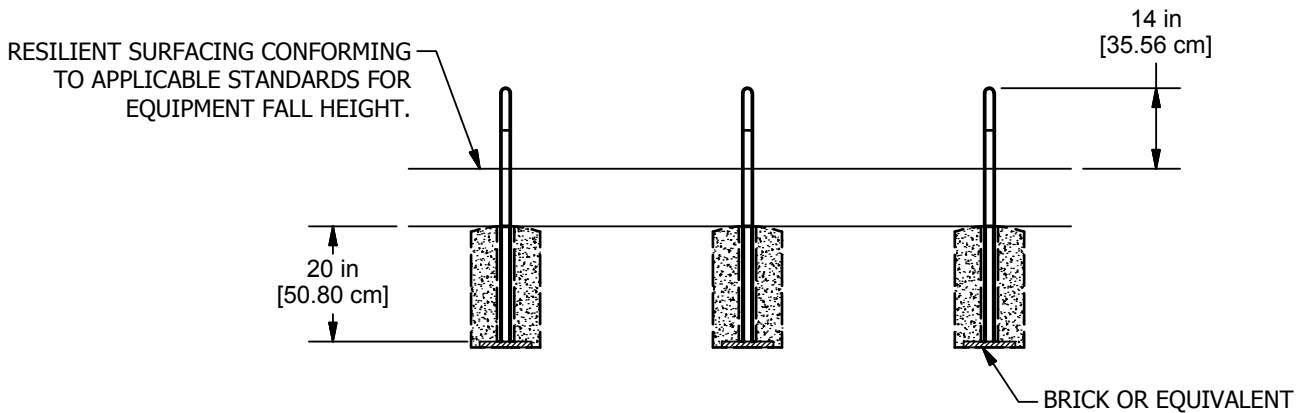

ELEVATION VIEW

Issued/Revised: 9/30/16



800.458.5872

www.actionfitoutdoors.com