

UP262 BODY CURL STATION

Parts List		
DESCRIPTION	QTY	PART NUMBER
BODY CURL BAR	1	147886
LOWER RIGHT SUPPORT	1	147892
LOWER LEFT SUPPORT	1	147894
UPPER RIGHT SUPPORT	1	147897
UPPER LEFT SUPPORT	1	147899
PUNCHED STEEL BENCH ASS'Y	1	160188
HARDWARE COMPLETE	1	403976
1/2" ANCHOR ROD	4	135038*
3/8" HEX NUT	12	804053*
3/8" x 1 1/4" B.H.C.S.	12	811051*
3/8" LOCKWASHER	12	817334*
3/8" FLAT WASHER (1 1/4" O.D.)	16	817424*
USAGE/WARNING LABEL	1	403869*

Unless Otherwise Specified, All Units of Measure are Each

**Items listed below Hardware Complete line are included with Hardware Complete Number*

Warning: During Installation, Hardware And Small Parts Are Choking Hazards For Young Children. Store Unused Parts Appropriately Until Assembly Is Completed. Once Assembly Is Completed, Remove Any Unused Parts From The Play Environment And Dispose/Save Them In A Secure Location. Any bolt end protruding more than two full threads beyond the face of the nut causes risk of clothing entanglement.

Promptly cut-off flush, file smooth, and treat to prevent corrosion.

Note: Peen Tee-Nuts and Flatwashers to match radius of pipe after assembly is complete.

Note: Loctite (supplied by others) should be used on any non-patch hardware.

SPECIFICATIONS:

SUPPORT ASSEMBLIES: Shall be an all-welded construction fabricated of 2-3/8" O.D. standard galvanized pipe, 3/16" x 6" H.R. flat steel formed plate and 3/16" x 1-1/2" H.R. flat steel gusset.

BENCH ASSEMBLY: Shall be fabricated of punched steel metal with a plastisol coating.

BODY CURL BAR ASSEMBLY: Shall be an all-welded construction fabricated of 1-5/16" O.D. galvanized formed handrail, 3/16" x 3" H.R. flat steel handrail plate, and galvanized pipe cap.

FINISH: Leg and Handrail assemblies shall all have a powder coat finish.

HARDWARE: All nuts, bolts, screws, inserts, and lockwashers used in the assembly of all play equipment, shall be stainless steel, yellow dichromate plated steel, blue-coat plated steel, mechanically galvanized or powder coated/yellow dichromate plated steel. All primary fasteners shall be 300 series stainless steel. Fasteners with yellow dichromate treatment have an electro deposited, 99.9% pure zinc substrate applied from a specially formulated solution sealed with a yellow dichromate top coat designed to work in conjunction with the zinc plating. Yellow dichromate has a 320% longer life to white corrosion and 275% longer to red corrosion than does hot-dip galvanizing.

ActionFit Traditional

UP262 BODY CURL STATION

INSTALLATION INSTRUCTIONS:

NOTE: Do not overtighten bolts. To overtighten may cause buckling or dimpling of some parts.

NOTE: Read installation instructions thoroughly before starting assembly. Pour concrete only after final assembly is completed. Bracing material is required during assembly.

NOTE: Assembly and leveling times will be greatly reduced if a transit is used to set location and depth of ground holes.

1. Before starting assembly, review the General Installation Instructions at the beginning of this Installation Guide and the Typical Assembly Details in the back.
2. Determine proper location for Body Curl Station. Refer to Equipment Layout Plan provided and any applicable project site drawings.
3. Dig footings for bench supports and Sign Post. Maintain footing spacing, size and depth as indicated on the ground plan. Allow for depth of desired Finished Surface.
4. Attach four support legs to the bench using 3/8" Hex Nut, 3/8" Lockwasher, 3/8" Flatwasher, and 3/8" x 1 1/4" B.H.C.S. Refer to Detail E06.
5. Attach Body Curl Bar to the bench using 3/8" Hex Nut, 3/8" Lockwasher, 3/8" Flatwasher, and 3/8" x 1 1/4" B.H.C.S. Refer to Detail E05.
6. Position assembled bench in footings; align, plumb, and brace bench in place. Be sure to hold top of concrete footing 10" [25.40cm] down from the Finished Surface. Slope top of concrete for proper drainage.
7. Allow concrete a minimum of 48 hours to cure and harden before using bench.

MAINTENANCE PROCEDURE:

Periodically check hardware for tightness, and tighten as necessary, also check if the entrapments and protrusions still satisfactory. Always check all metal parts for paint peeling, corrosion and touch up if necessary. Check all parts for cracks, breakage or wear, and immediately put equipment out of service until any faulty parts found are repaired or replaced. Check periodically resilient surfacing for appropriate depth and remove extraneous materials that could cause injury, infection, or disease. Maintain detailed installation, inspection, maintenance, and repair records for each public-use playground equipment.

UP262 BODY CURL STATION

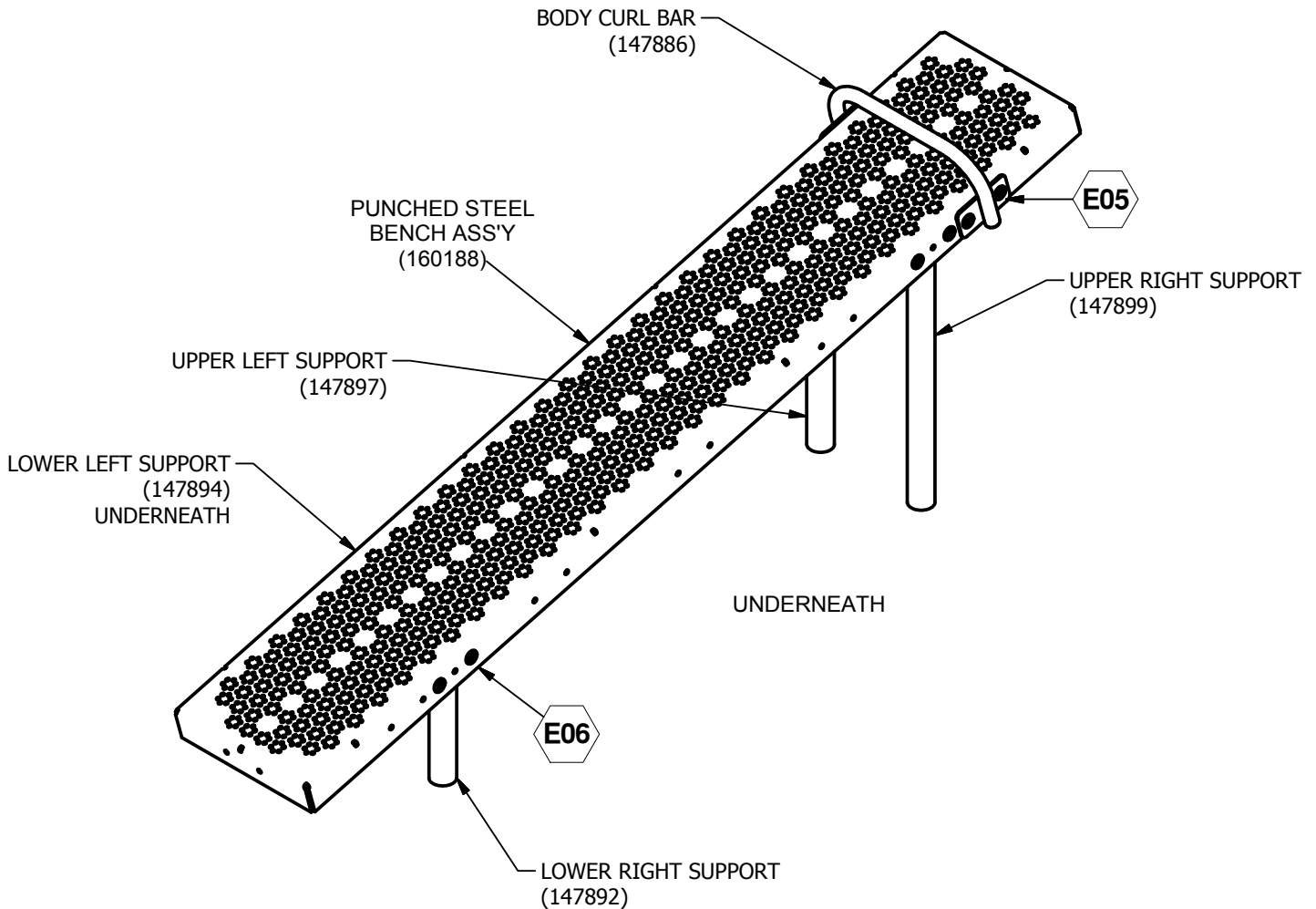

FINISHED ASSEMBLY

NOTE:
 MINIMUM OF ONE USAGE/WARNING LABEL
 SIGN POST (UP197) MUST BE USED WITH EACH
 BODY CURL STATION. SEE SIGN POST
 INSTALLATION SHEET FOR INSTALLATION DETAILS.

**SIGN POST MUST BE OUTSIDE MAXIMUM SPACE IN WHICH
 THE USER AND EXERCISE EQUIPMENT COMPONENTS
 TRAVERSE WHEN THE EQUIPMENT IS OPERATED.**

 = INSTALLATION DETAIL

Issued/Revised: 9/30/16



800.458.5872

www.actionfitoutdoors.com

ActionFit Traditional

UP262 BODY CURL STATION

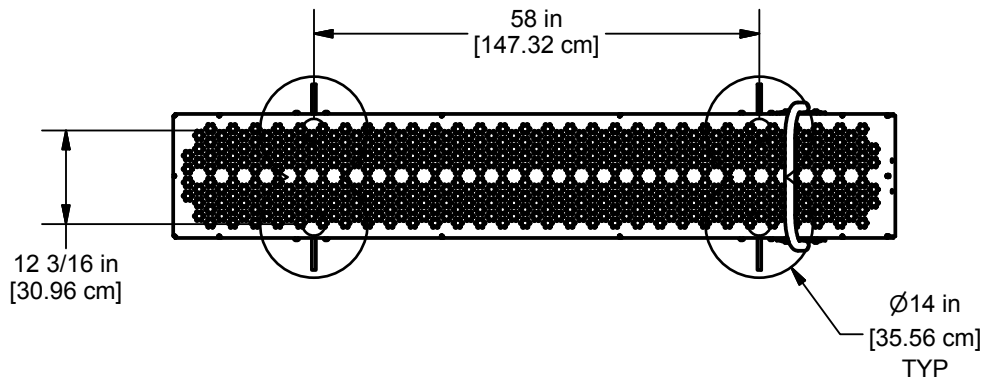

PLAN VIEW

CONCRETE REQUIRED:
0.28 CUBIC YARDS
[0.20 CUBIC METERS]

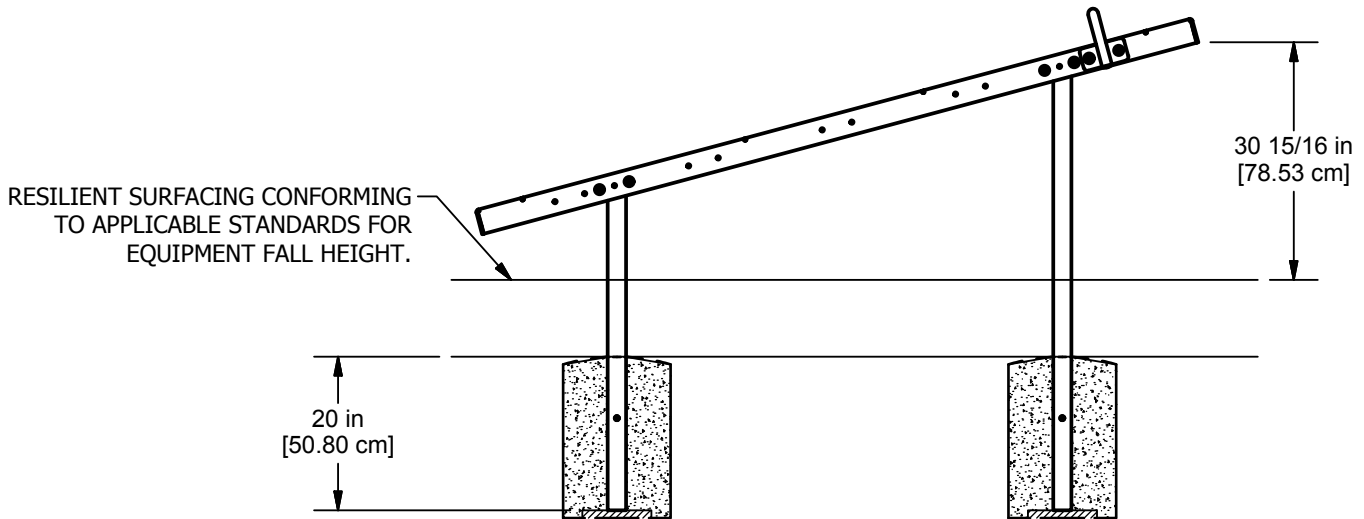

ELEVATION VIEW

Issued/Revised: 9/30/16



800.458.5872

www.actionfitoutdoors.com

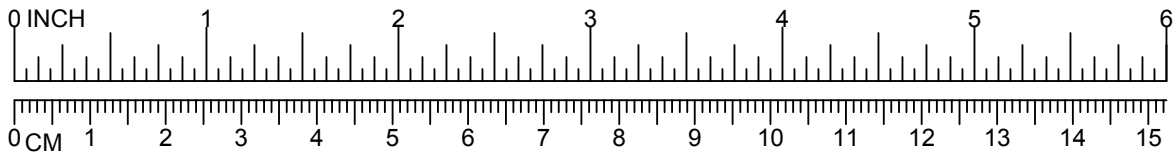

UP262 BODY CURL STATION

