



By **ultra site**
A **PLAYCORE** Company

1-800-458-5872

ISSUED/REVISED: 3/31/20

UP233

ADULT CLIMBING WALL

9'-0" UP233
10'-0" UP234

- = INSTALLATION DETAIL
- = PARTS LIST REFERENCE

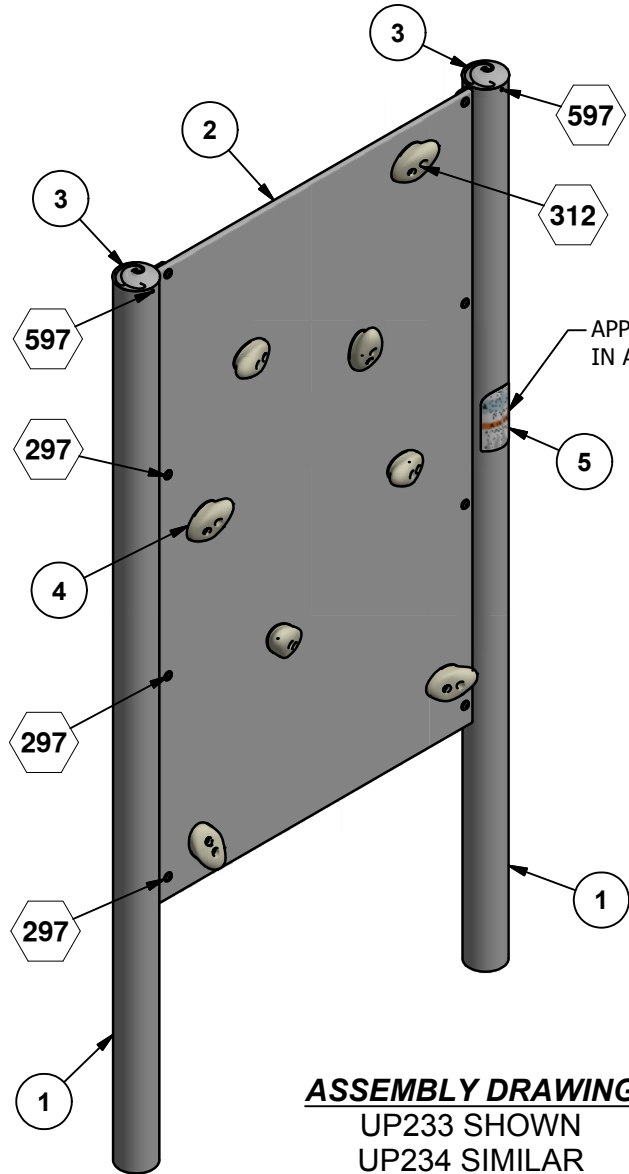

ASSEMBLY DRAWING
UP233 SHOWN
UP234 SIMILAR

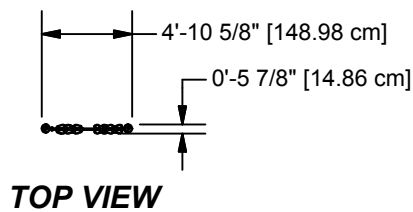

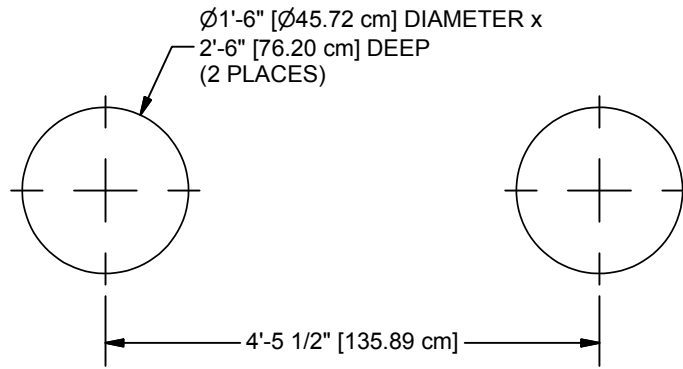

GROUND PLAN

CONCRETE REQUIRED:
 .20 CUBIC YARDS
 [.15 CUBIC METERS]

NOTE: HOLE DEPTHS INDICATED ON ALL GROUND PLANS ARE MEASURED FROM THE FINISHED SURFACE. SEE DETAIL 321. ALL FOOTING DIMENSIONS ARE BASED ON LEVEL FINISHED SURFACE.

Parts List				
REF	DESCRIPTION	UP233	UP234	PART NUMBER
1	UPRIGHT ASS'Y	2	0	204776
1	UPRIGHT ASS'Y	0	2	204780
2	CLIMBING WALL	1	0	204777
2	CLIMBING WALL	0	1	204781
3	SWIRL CAP	2	2	213000
	HARDWARE COMPLETE	1	0	408020
	HARDWARE COMPLETE	0	1	408021
4	CLIMBER HANDHOLD #2	16	20	311376*
	3/16" x 13/32" DRIVE RIVET	4	4	805366*
	5/16" x 2 1/2" P.B.H.C.S. w/PATCH	16	20	812048*
	5/16" FLATWASHER (3/4" O.D.)	16	20	817404*
	5/16" LOCK WASHER	16	20	817330*
	5/16" STAINLESS STEEL BARREL NUT	16	20	804813*
	3/8" x 1" P.B.H.C.S. w/PATCH	8	10	812050*
	3/8" FLAT WASHER (1 1/4" O.D.)	8	10	817424*
	3/8" LOCK WASHER	8	10	817334*
	3/8" BARREL NUT	8	10	804804*
	1/2" FLAT WASHER	8	10	817412*
5	USAGE/WARNING LABEL	1	1	408012*

*Unless Otherwise Specified, All Units of Measure are Each
 * Included in Hardware*

Warning: During Installation, Hardware And Small Parts Are Choking Hazards For Young Children. Store Unused Parts Appropriately Until Assembly Is Completed. Once Assembly Is Completed, Remove Any Unused Parts From The Play Environment And Dispose/Save Them In A Secure Location.

Note: Peen Tee-Nuts and Flatwashers to match radius of pipe after assembly is complete.

Note: Loctite (supplied by others) should be used on any non-patch hardware.

INSTALLATION INSTRUCTIONS

NOTE: Do not overtighten bolts. To overtighten may cause buckling or dimpling of some parts.

NOTE: Read Installation Instructions thoroughly before starting assembly. Pour concrete only after final assembly is complete. Bracing material may be required during assembly.

NOTE: Bracing may be needed to stabilize the Fitness Wall while concrete hardens.

STEP 1: Lay out the ground holes using the Ground Plan.

NOTE: Due to extremes in weather and soil conditions, hole size may have to be increased to meet local conditions.

STEP 2: After digging the ground holes place a brick or equivalent in the bottom of each hole to provide a solid foundation for the climber. See Footing Detail 321.

STEP 3: Attach Swirl Cap to Upright Assembly. See Detail 597.

STEP 4: Attach Climbing Wall to Upright Assemblies. See Detail 297.

STEP 5: Attach Climber Handholds to Climbing Wall. See Detail 312.

SPECIFICATIONS

NOTE: THIS SPECIFICATION BOOKLET SHOULD BE KEPT IN CUSTOMERS FILE FOR FUTURE REFERENCE.

NOTE: Read installation instructions thoroughly before starting assembly. Pour concrete only after final assembly is complete. Bracing material may be required during assembly.

NOTE: Do not overtighten bolts. To overtighten may cause buckling or dimpling of some parts.

NOTE: Do not tighten any nuts, bolts, rods, etc. until the unit is completely assembled

UPRIGHTS ASS'Y: Shall be fabricated from 5" O.D. x .120" (11 Gauge) wall galvanized steel tubing and 3/16" Thick H.R. Steel. Manufactured to ASTM A-500 Section 10 tolerances from cold-formed steel conforming to ASTM A-569. Minimum yield strength shall be 50,000 psi and minimum tensile strength shall be 55,000 psi. The exterior surface is hot dip galvanized, chromate conversion coated, and a clear high performance organic polymer is applied. The inside diameter has 81% minimum zinc rich primer capable of providing excellent rust protection and fabrication characteristics. All coatings are applied inside and out after welding for superior corrosion protection throughout. Exterior surface galvanizing zinc purity is 99% as per ASTM B-6 high grade and special high grade.

HDPE PANEL: Shall be fabricated from 3/4" thick (solid) high density, UV-stabilized and color impregnated polyethylene.

POWDER COAT FINISH: Shall be an electrostatically applied custom formula of TGIC polyester powder. All components will be free of sharp edges and excess weld spatter and shall be cleaned in a four stage solvent / zirconium based bath system (free of iron phosphate), as a rust inhibitor, and a zirconium conversion coating to prevent flash rusting before coating. In addition, all welds shall be protectively coated with ZRP, a zinc rich primer that forms a rust-resistant barrier layer over each weld prior to application of the powder coating. The powder coating shall have a super tough finish with maximum exterior durability and will have superior adhesion characteristics. Typical characteristics are: Two coat process to achieve 3.0 - 5.0 mil thickness and oven cured between 350 degrees Fahrenheit. Pencil Hardness H (ASTM D-3363), Impact (ASTM D-2794- 69), Wedge Bend (ASTM D-522-68), Adhesion (Cross Hatch ASTM D-3359 & Knife Scratch ASTM D-2197), Environmental (Stain Resistance ASTM D-1308, Humidity ASTM D-2247 - 87, Salt Spray ASTM B-117 & Fadometer 300 hrs with no loss of gloss), Over-bake Stability 100% at 350 degrees Fahrenheit for 10 minutes.

HARDWARE: All nuts, bolts, screws, inserts, and lockwashers used in the assembly of all play equipment, shall be stainless steel, yellow dichromate plated steel, blue-coat plated steel, mechanically galvanized or powder coated/yellow dichromate plated steel. All primary fasteners shall be 300 series stainless steel. Fasteners with yellow dichromate treatment have an electro deposited, 99.9% pure zinc substrate applied from a specially formulated solution sealed with a yellow dichromate top coat designed to work in conjunction with the zinc plating. Yellow dichromate has a 320% longer life to white corrosion and 275% longer to red corrosion than does hot-dip galvanizing. NOTE: All weights are based on average comparisons of each part.

SPECIFICATIONS: ULTRASITE® has a policy of continuous improvement and reserves the right to discontinue or change specifications without notice.



IMPORTANT PRODUCT INFORMATION AND SAFETY WARNINGS



- Climbing Walls should be installed on a soft, resilient, energy-absorbing ground surface. NEVER INSTALL PLAY EQUIPMENT ON CONCRETE OR ASPHALT. A fall on a hard surface can result in serious injury to the equipment user.
- ALWAYS FOLLOW INSTALLATION INSTRUCTIONS WHEN ERECTING EQUIPMENT.
- Worn surfaces around equipment should be restored. Concrete footings should never be exposed. Surface depth should comply with installation instructions.
- Equipment should be placed to eliminate conflicting traffic patterns.
- All equipment should be free of rust and repainted whenever necessary to deter rusting.
- All protruding nuts and bolts should be covered; sharp edges on pipes should be capped or removed. Check for bent, broken or severely worn pipe and replace.
- Test overall stability and rigidity of all fitness equipment. Check for proper assembly, installation and ground anchoring.
- Check for and repair damage caused by wear or vandalism, a major factor in injury-causing situations.
- ULTRASITE® PROVIDES ITS CUSTOMERS WITH COMPLETE SPECIFICATION SHEETS AND INSTALLATION INSTRUCTIONS. THE SPECIFICATION SHEET CONTAINS THE LISTING OF EVERY PART USED IN A PIECE OF EQUIPMENT AND SHOULD BE KEPT IN THE CUSTOMER'S FILES FOR ACCURATE REFERENCE WHEN REPLACEMENT PARTS ARE NEEDED.
- Never add components not intended for use with this product.
- Regular checking of all parts, castings, etc. should be made. If a part is broken or worn it should be replaced immediately.
- Proper maintenance of ULTRASITE® equipment requires regular tightening of all bolts, nuts, and set screws.
- Check to be sure all fittings are tight and that the bars and pipes do not move.

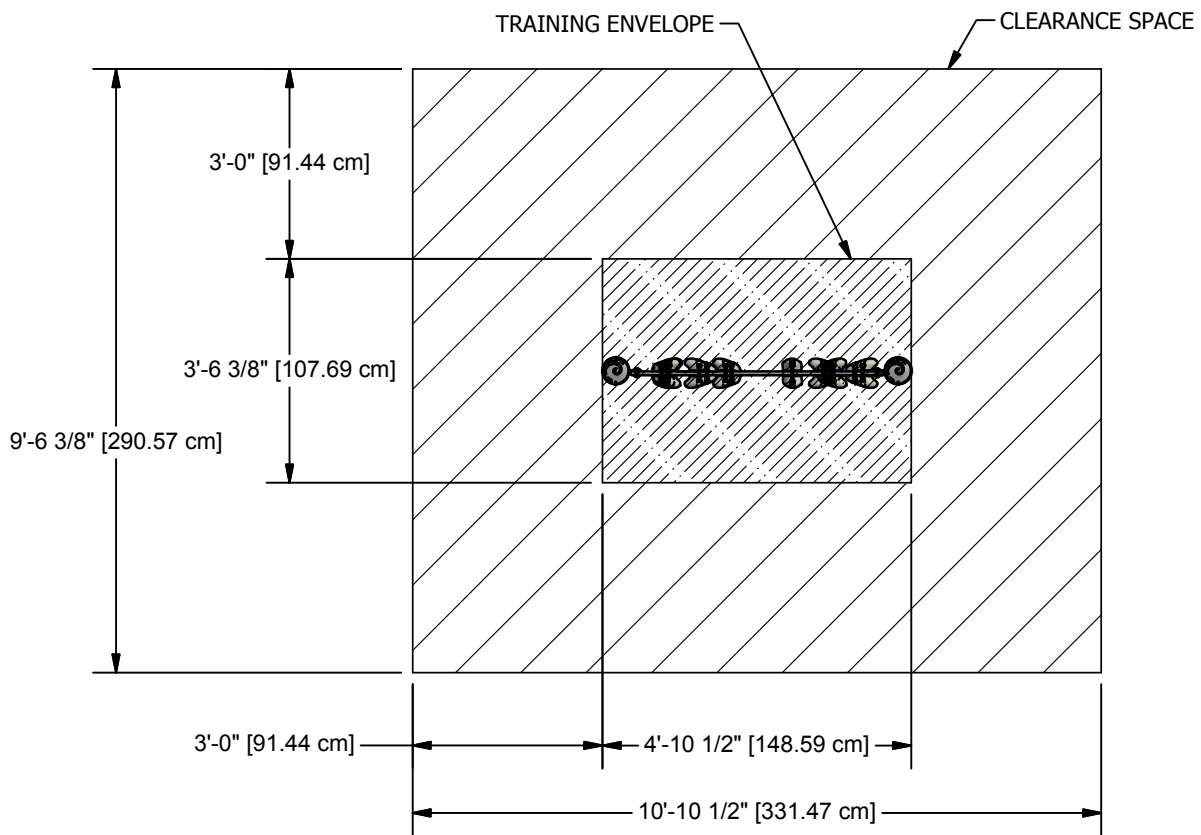

TRAINING ENVELOPE/CLEARANCE SPACE

NOTE: OWNER/OPERATOR SHALL KEEP THE TRAINING ENVELOPE AND CLEARANCE SPACE OF THE OUTDOOR FITNESS EQUIPMENT FREE FROM EXTRANEIOUS MATERIALS THAT COULD CAUSE INJURY, INFECTION OR DISEASE.

DETAILS -for- UP233, UP234

IMPORTANT

TO REDUCE THE RISK OF CLOTHING ENTANGLEMENT IN COMPLIANCE WITH ASTM F1487, ANY BOLT END PROTRUDING MORE THAN TWO FULL THREADS BEYOND THE FACE OF THE NUT SHALL BE CUT-OFF FLUSH, FILED SMOOTH AND TREATED TO PREVENT CORROSION.

NOTE: LOCTITE (SUPPLIED BY OTHERS) SHOULD BE USED ON ALL THREADED HARDWARE.

NOTE: AFTER ASSEMBLY IS COMPLETE, PEEN TEE-NUTS AND FLATWASHERS TO MATCH RADIUS OF PIPE.

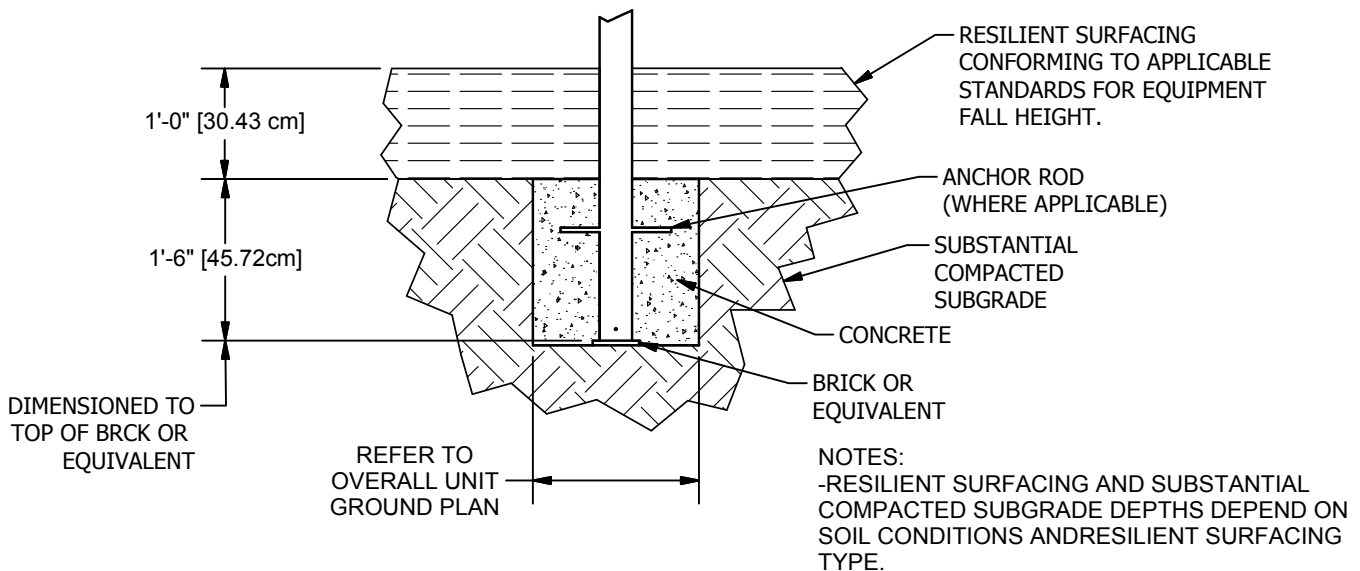
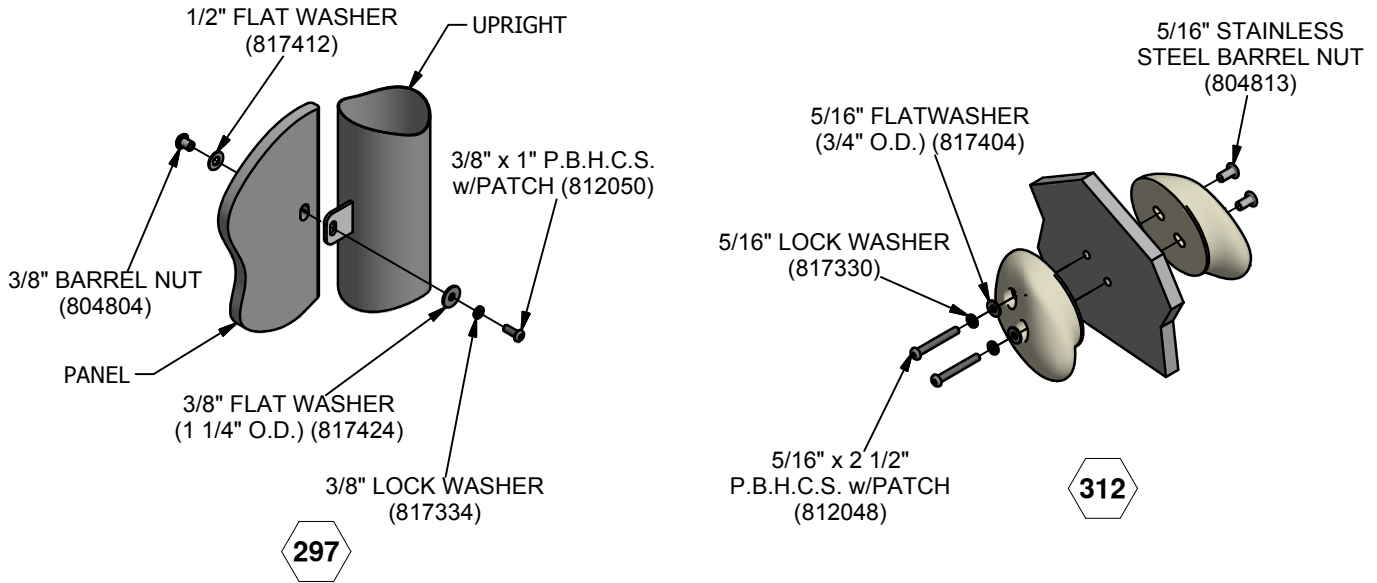
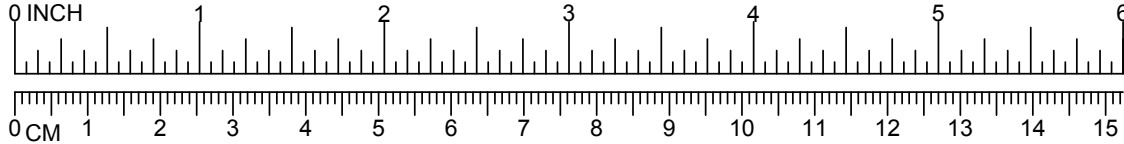

SHOCK ABSORBING PROPERTIES OF SURFACING MATERIALS MAY VARY. IF YOU DETERMINE THAT LESS THAN 1'-0" [30.48cm] OF SURFACING IS REQUIRED, MAKE UP THE DIFFERENCE IN ELEVATION WITH EARTH BEFORE APPLYING SURFACING.

-SLOPED FOOTINGS IS A REQUIREMENT OF EUROPEAN STANDARD EN1176-1 ONLY

-SUGGESTED MINIMUM CONCRETE RATING 3000PSI.

321

DETAILS -for- UP233, UP234

IMPORTANT

TO REDUCE THE RISK OF CLOTHING ENTANGLEMENT IN COMPLIANCE WITH ASTM F1487, ANY BOLT END PROTRUDING MORE THAN TWO FULL THREADS BEYOND THE FACE OF THE NUT SHALL BE CUT-OFF FLUSH, FILED SMOOTH AND TREATED TO PREVENT CORROSION.

NOTE: LOCTITE (SUPPLIED BY OTHERS) SHOULD BE USED ON ALL THREADED HARDWARE.

NOTE: AFTER ASSEMBLY IS COMPLETE, PEEN TEE-NUTS AND FLATWASHERS TO MATCH RADIUS OF PIPE.

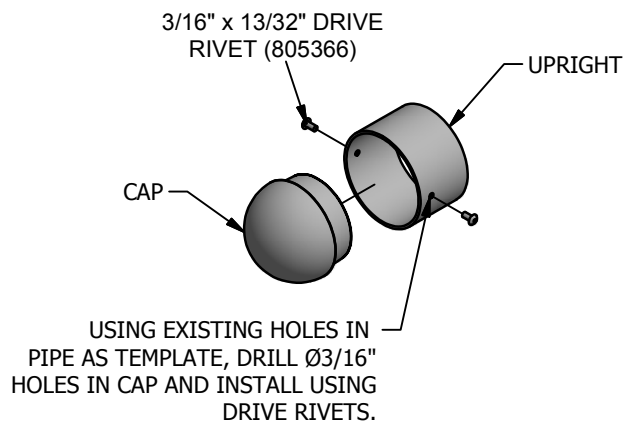
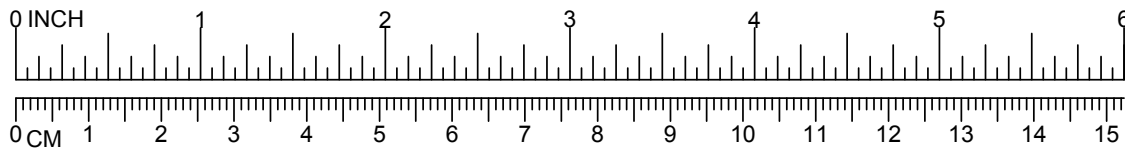

597