



TRAPEZE RACK

-  = INSTALLATION DETAIL
-  = PARTS LIST REFERENCE

AGES 18+

TRAPEZE RACK 13198
TRAPEZE RACK AAB 13198
AAB = ADD-A-BAY

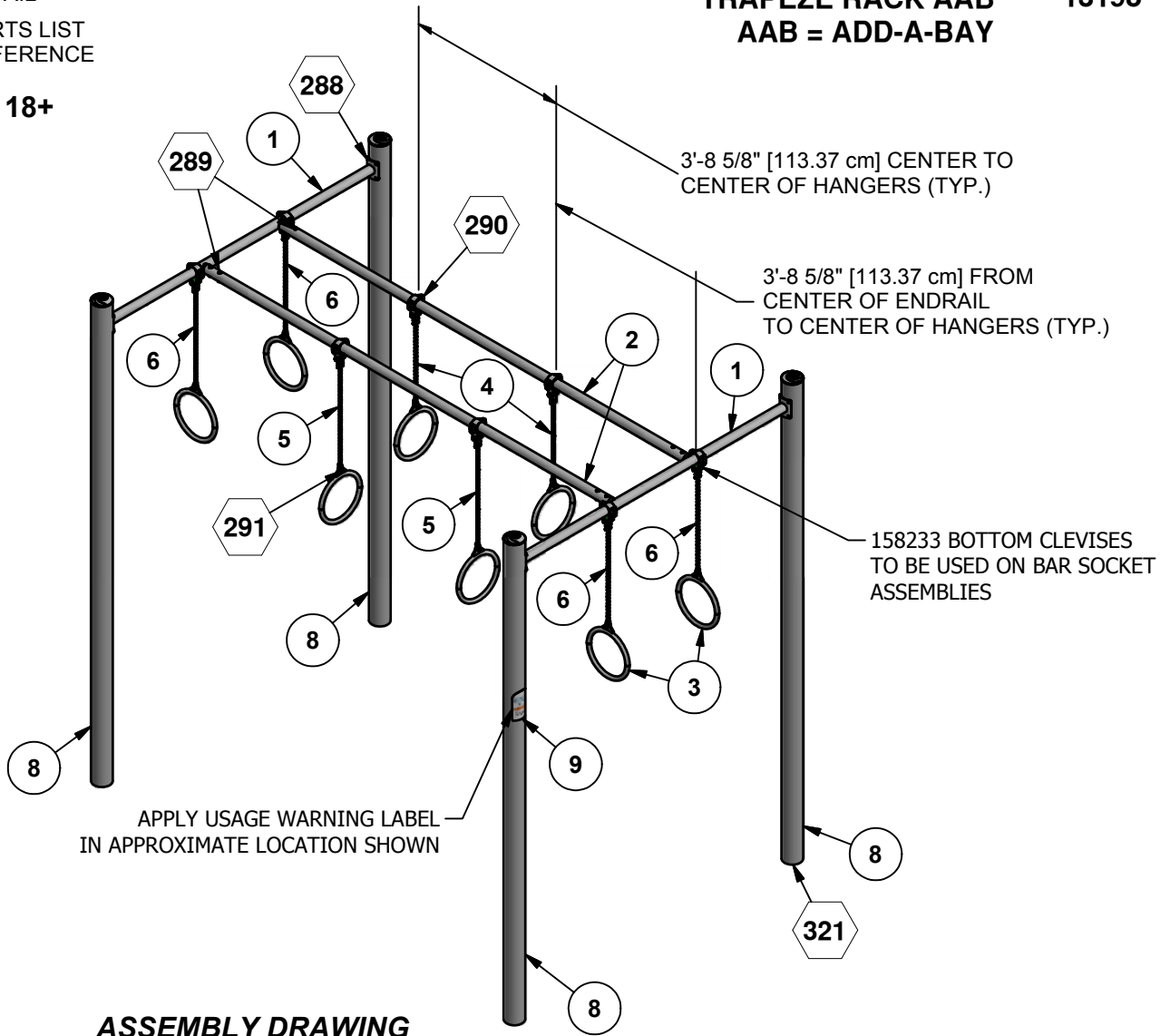

APPLY USAGE WARNING LABEL
IN APPROXIMATE LOCATION SHOWN

ASSEMBLY DRAWING
UP231

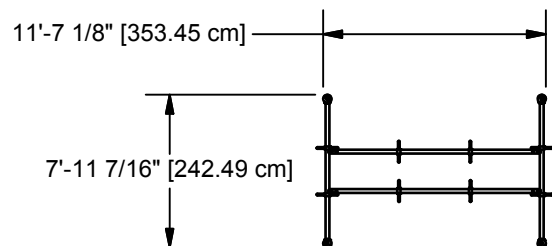

TOP VIEW
UP231

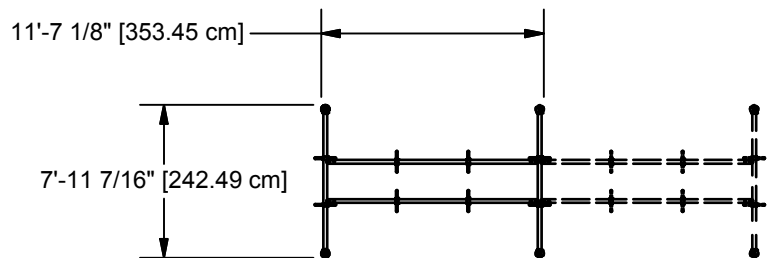
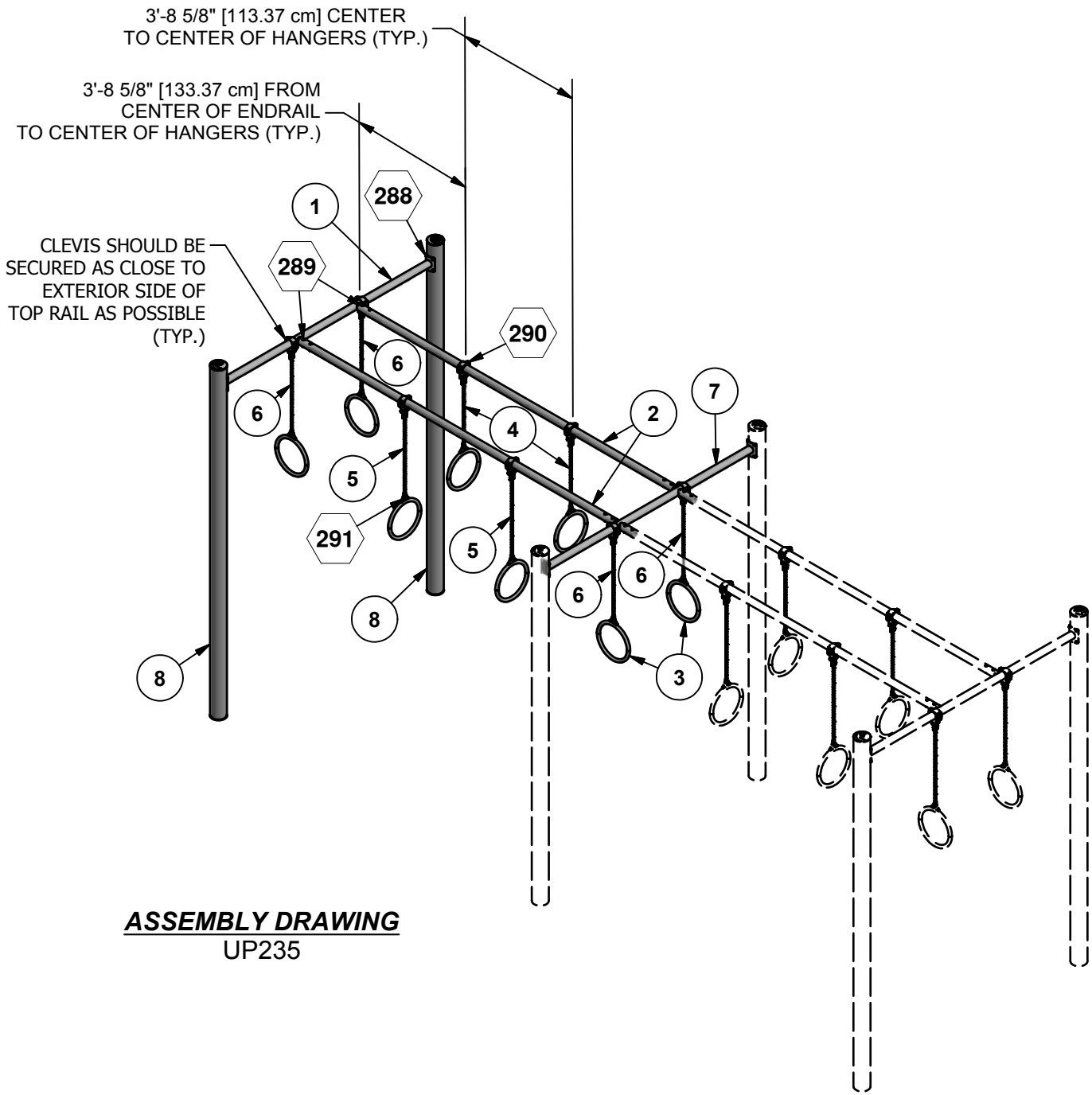

TOP VIEW
UP235

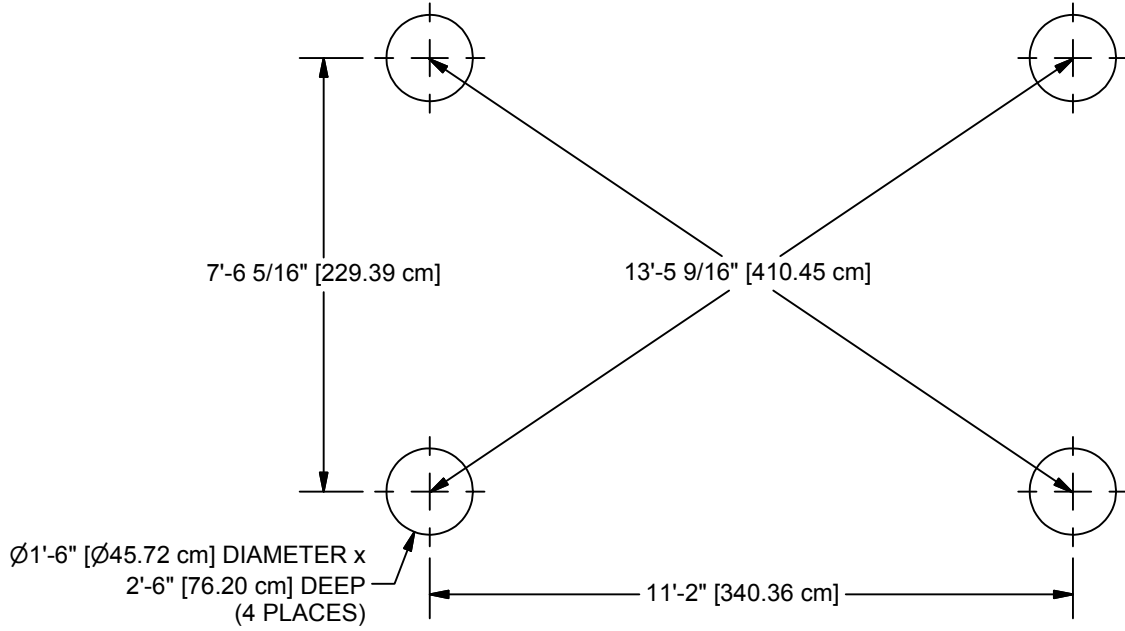

Ø1'-6" [Ø45.72 cm] DIAMETER x
2'-6" [76.20 cm] DEEP
(4 PLACES)

CONCRETE REQUIRED:
.39 CUBIC YARDS
[.30 CUBIC METERS]

GROUND PLAN
UP231

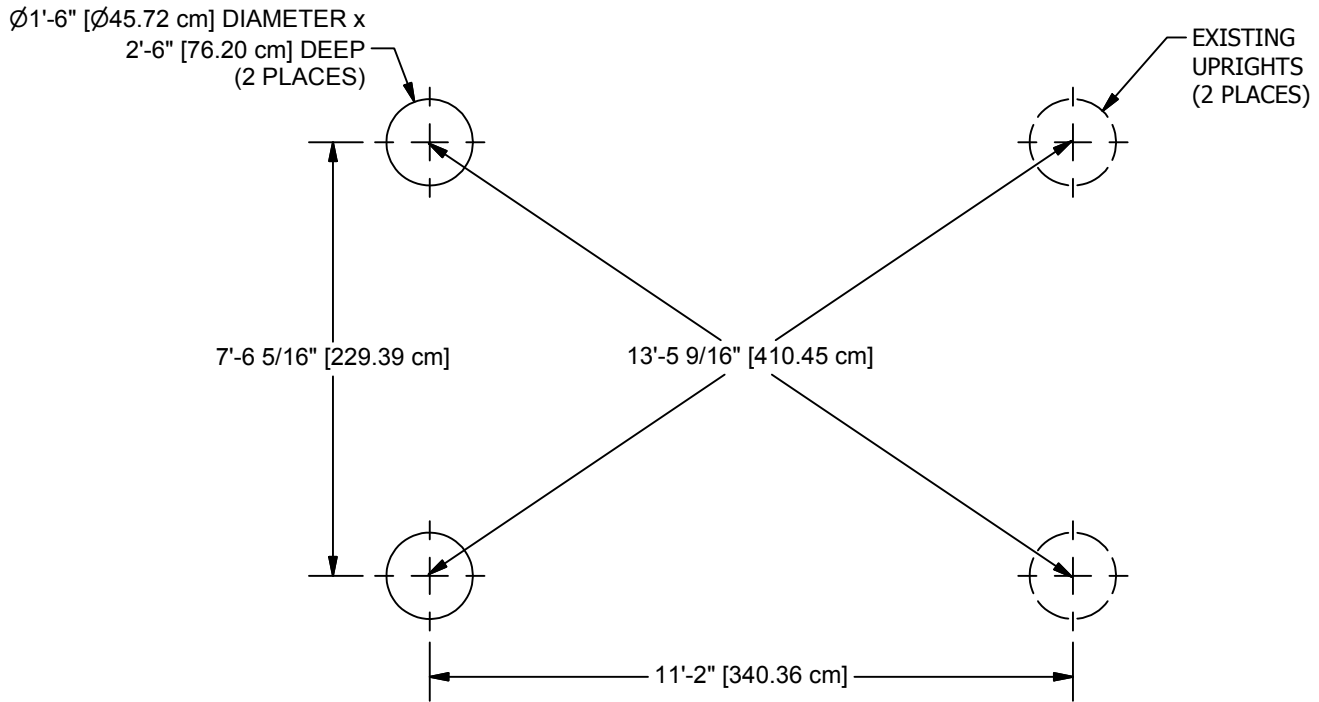

Ø1'-6" [Ø45.72 cm] DIAMETER x
2'-6" [76.20 cm] DEEP
(2 PLACES)

EXISTING
UPRIGHTS
(2 PLACES)

CONCRETE REQUIRED:
.20 CUBIC YARDS
[.15 CUBIC METERS]

GROUND PLAN
UP235

NOTE: HOLE DEPTHS INDICATED ON ALL GROUND PLANS ARE MEASURED FROM THE FINISHED SURFACE. SEE DETAIL 298. ALL FOOTING DIMENSIONS ARE BASED ON LEVEL FINISHED SURFACE.

Parts List				
REF	DESCRIPTION	UP231	UP235	PART NUMBER
1	END RAIL WELD ASS'Y	2	1	213676
2	TOP RAIL	2	2	205775
3	RING WELD ASS'Y	8	8	205764
4	CHAIN 22 11/16"	2	2	204695
5	CHAIN 28 1/4"	2	2	205773
6	CHAIN 26 7/8'	4	4	205772
7	AAB END RAIL WELD ASS'Y	0	1	213679
8	UPRIGHT	4	2	LIT8HW
	TOP CLEVIS (2 3/8")	8	8	158223
	TRAPEZE BOTTOM CLEVIS ASS'Y (2 3/8")	4	4	158227
	BOTTOM CLEVIS ASSEMBLY (2 3/8")	4	4	158233
	HARDWARE COMPLETE	1	0	408022
	HARDWARE COMPLETE	0	1	408023
	3/8" x 1" BUTTON HEAD SHOULDER BOLT	8	8	811226*
	3/8" x 1" P.B.H.C.S. w/PATCH	16	8	812050*
	3/8" x 2" CARRIAGE BOLT	16	16	800256*
	3/8" x 2 1/4" P.B.H.C.S. w/PATCH	8	8	812056*
	3/8" LOCK WASHER	24	16	817334*
	3/8" LOCK NUT	16	16	804353*
	3/8" BARREL NUT	8	8	804804*
	1/2" x 2 1/2" HEX HEAD BOLT	8	8	801200*
	1/2" LOCKWASHER	8	8	817342*
	1/2" HEX NUT	8	8	804055*
	PENDULUM	8	8	157010*
	CLEVIS w/SPECIAL HEAD	8	8	166683*
9	USAGE/WARNING LABEL	1	0	408010*

*Unless Otherwise Specified, All Units of Measure are Each
* Included in Hardware*

Warning: During Installation, Hardware And Small Parts Are Choking Hazards For Young Children. Store Unused Parts Appropriately Until Assembly Is Completed. Once Assembly Is Completed, Remove Any Unused Parts From The Play Environment And Dispose/Save Them In A Secure Location.

Note: Peen Tee-Nuts and Flatwashers to match radius of pipe after assembly is complete.
Note: Loctite (supplied by others) should be used on any non-patch hardware.

INSTALLATION INSTRUCTIONS

NOTE: Do not overtighten bolts. To overtighten may cause buckling or dimpling of some parts.

NOTE: Read Installation Instructions thoroughly before starting assembly. Pour concrete only after final assembly is complete. Bracing material may be required during assembly.

NOTE: Bracing may be needed to stabilize Trapeze Rack and Fitness Sign while concrete hardens.

STEP 1: Lay out the ground holes using the Ground Plan.

NOTE: Due to extremes in weather and soil conditions, hole size may have to be increased to meet local conditions.

STEP 2: After digging the ground holes place a brick or equivalent in the bottom of each hole to provide a solid foundation for the climber. See footing Detail 321.

STEP 3: Attach the Two Top Rails to End Rail Weld Ass'y using Detail 289.

STEP 4: Attach the End Rail Weld Assemblies to the Uprights using Detail 288.

STEP 5: Attach the Swing Hangers to the Top Rail using Detail 290.

STEP 6: Attach the Ring Weld Ass'y using Detail 291.

STEP 7: Level and plumb the Trapeze Rack.

SPECIFICATIONS

END RAIL WELD ASSEMBLY: Shall be fabricated from 2-3/8" O.D. x .134" (10 Gauge) wall galvanized steel tubing and 1/4" Thick H.R. Steel. End Rail Weld Assembly shall be an all weld assembly and shall be coated after fabrication with a custom formula of TGIC polyester powder coating in conformance with the specifications outlined herein.

TOP RAIL: Shall be fabricated from 2-3/8" O.D. x .134" (10 Gauge) wall galvanized steel tubing. Top Rail shall be coated after fabrication with a custom formula of TGIC polyester powder coating in conformance with the specifications outlined herein.

RING WELD ASSEMBLY: Shall be fabricated from 1-1/16" O.D. x .072 (15 Gauge) wall galvanized steel tubing and 3/8" Thick H.R. Steel. Ring Weld Assembly shall be an all weld assembly and shall be coated after fabrication with a custom formula of TGIC polyester powder coating in conformance with the specifications outlined herein.

AAB END RAIL WELD ASSEMBLY: Shall be fabricated from 2-3/8" O.D. x .134" (10 Gauge) wall galvanized steel tubing and 1/4" Thick H.R. Steel. AAB End Rail Weld Assembly shall be an all weld assembly and shall be coated after fabrication with a custom formula of TGIC polyester powder coating in conformance with the specifications outlined herein.

UPRIGHTS: Shall be fabricated from 5" O.D. x .120" (11 Gauge) wall galvanized steel tubing, manufactured to ASTM A-500 Section 10 tolerances from cold-formed steel conforming to ASTM A-569. Minimum yield strength shall be 50,000 psi and minimum tensile strength shall be 55,000 psi. The exterior surface is hot dip galvanized, chromate conversion coated, and a clear high performance organic polymer is applied. The inside diameter has 81% minimum zinc rich primer capable of providing excellent rust protection and fabrication characteristics. All coatings are applied inside and out after welding for superior corrosion protection throughout. Exterior surface galvanizing zinc purity is 99% as per ASTM B-6 high grade and special high grade.

TOP AND BOTTM CLEVIS ASSEMBLY: The swing hanger shall consist of a top clevis, bottom clevis and swing pendulum. The top clevis shall have a non-slip-serrated surface. The swing hangers shall be cast of malleable iron and shall have a galvanized finish. The pendulum shall be attached to the bottom clevis with 1/2" diameter bolts. The top and bottom clevis shall be attached with 3/8" diameter hardware.

POWDER COAT FINISH: Shall be an electrostatically applied custom formula of TGIC polyester powder. All components will be free of sharp edges and excess weld spatter and shall be cleaned in a four stage solvent / zirconium based bath system (free of iron phosphate), as a rust inhibitor, and a zirconium conversion coating to prevent flash rusting before coating. In addition, all welds shall be protectively coated with ZRP, a zinc rich primer that forms a rust-resistant barrier layer over each weld prior to application of the powder coating. The powder coating shall have a super tough finish with maximum exterior durability and will have superior adhesion characteristics. Typical characteristics are: Two coat process to achieve 3.0 - 5.0 mil thickness and oven cured between 350 degrees Fahrenheit. Pencil Hardness H (ASTM D-3363), Impact (ASTM D-2794- 69), Wedge Bend (ASTM D-522-68), Adhesion (Cross Hatch ASTM D-3359 & Knife Scratch ASTM D-2197), Environmental (Stain Resistance ASTM D-1308, Humidity ASTM D-2247 - 87, Salt Spray ASTM B-117 & Fadometer 300 hrs with no loss of gloss), Over-bake Stability 100% at 350 degrees Fahrenheit for 10 minutes.

HARDWARE: All nuts, bolts, screws, inserts, and lockwashers used in the assembly of all play equipment, shall be stainless steel, yellow dichromate plated steel, blue-coat plated steel, mechanically galvanized or powder coated/yellow dichromate plated steel. All primary fasteners shall be 300 series stainless steel. Fasteners with yellow dichromate treatment have an electro deposited, 99.9% pure zinc substrate applied from a specially formulated solution sealed with a yellow dichromate top coat designed to work in conjunction with the zinc plating. Yellow dichromate has a 320% longer life to white corrosion and 275% longer to red corrosion than does hot-dip galvanizing. NOTE: All weights are based on average comparisons of each part.

SPECIFICATIONS: ULTRASITE® has a policy of continuous improvement and reserves the right to discontinue or change specifications without notice.



IMPORTANT PRODUCT INFORMATION AND SAFETY WARNINGS



- Trapeze Rack should be installed on a soft, resilient, energy-absorbing ground surface. NEVER INSTALL PLAY EQUIPMENT ON CONCRETE OR ASPHALT. A fall on a hard surface can result in serious injury to the equipment user.
- ALWAYS FOLLOW INSTALLATION INSTRUCTIONS WHEN ERECTING EQUIPMENT.
- Worn surfaces around equipment should be restored. Concrete footings should never be exposed. Surface depth should comply with installation instructions.
- Equipment should be placed to eliminate conflicting traffic patterns.
- All equipment should be free of rust and repainted whenever necessary to deter rusting.
- All protruding nuts and bolts should be covered; sharp edges on pipes should be capped or removed. Check for bent, broken or severely worn pipe and replace.
- Test overall stability and rigidity of all fitness equipment. Check for proper assembly, installation and ground anchoring.
- Check for and repair damage caused by wear or vandalism, a major factor in injury-causing situations.
- ULTRASITE® PROVIDES ITS CUSTOMERS WITH COMPLETE SPECIFICATION SHEETS AND INSTALLATION INSTRUCTIONS. THE SPECIFICATION SHEET CONTAINS THE LISTING OF EVERY PART USED IN A PIECE OF EQUIPMENT AND SHOULD BE KEPT IN THE CUSTOMER'S FILES FOR ACCURATE REFERENCE WHEN REPLACEMENT PARTS ARE NEEDED.
- Never add components not intended for use with this product.
- Regular checking of all parts, castings, etc. should be made. If a part is broken or worn it should be replaced immediately.
- Proper maintenance of ULTRASITE® equipment requires regular tightening of all bolts, nuts, and set screws.
- Check to be sure all fittings are tight and that the bars and pipes do not move.

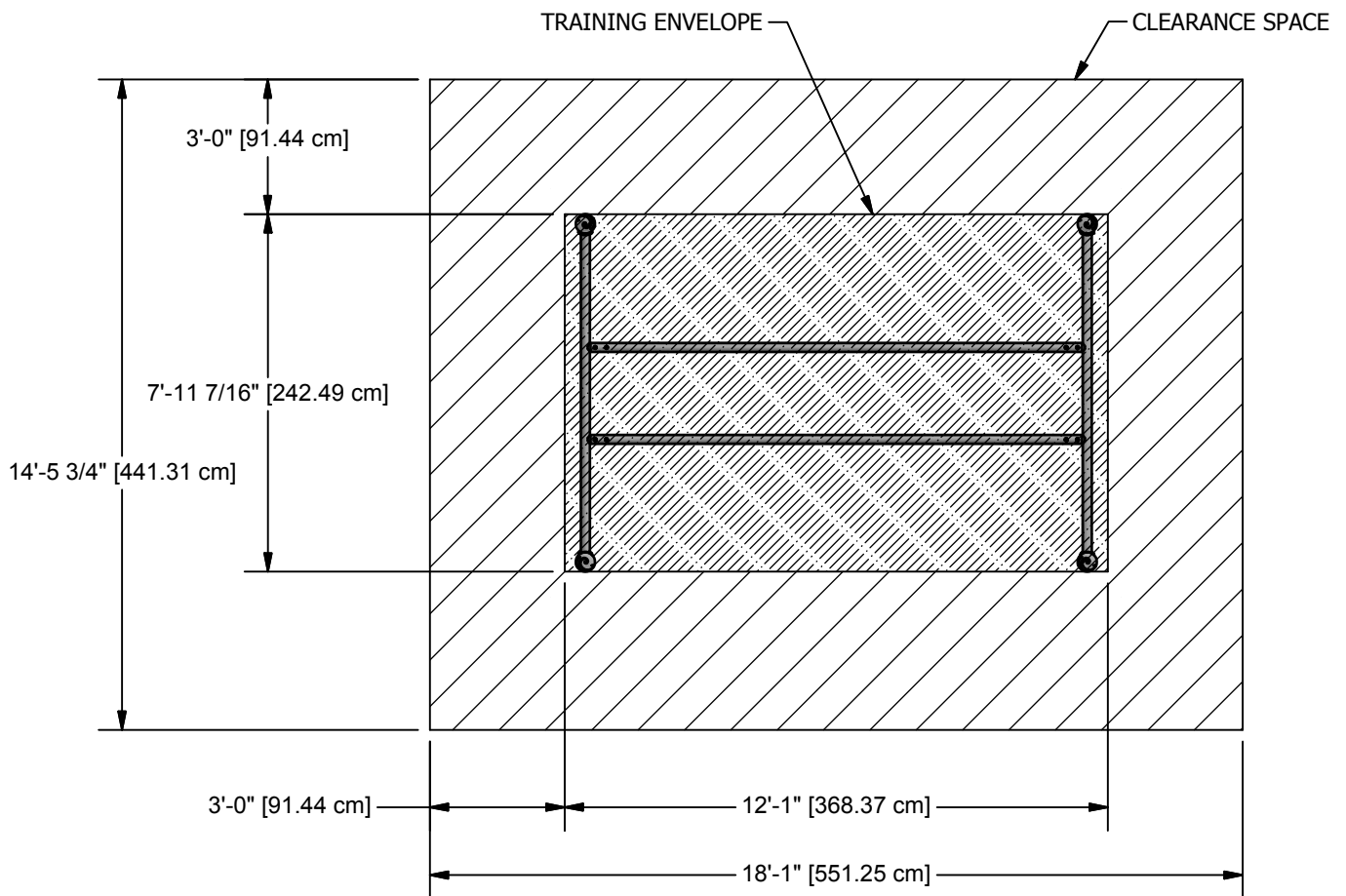

TRAINING ENVELOPE/CLEARANCE SPACE

NOTE: OWNER/OPERATOR SHALL KEEP THE TRAINING ENVELOPE AND CLEARANCE SPACE OF THE OUTDOOR FITNESS EQUIPMENT FREE FROM EXTRANEOUS MATERIALS THAT COULD CAUSE INJURY, INFECTION OR DISEASE.

DETAILS -for- UP231, UP235

IMPORTANT

TO REDUCE THE RISK OF CLOTHING ENTANGLEMENT IN COMPLIANCE WITH ASTM F1487, ANY BOLT END PROTRUDING MORE THAN TWO FULL THREADS BEYOND THE FACE OF THE NUT SHALL BE CUT-OFF FLUSH, FILED SMOOTH AND TREATED TO PREVENT CORROSION.

NOTE: LOCTITE (SUPPLIED BY OTHERS) SHOULD BE USED ON ALL THREADED HARDWARE.

NOTE: AFTER ASSEMBLY IS COMPLETE, PEEN TEE-NUTS AND FLATWASHERS TO MATCH RADIUS OF PIPE.

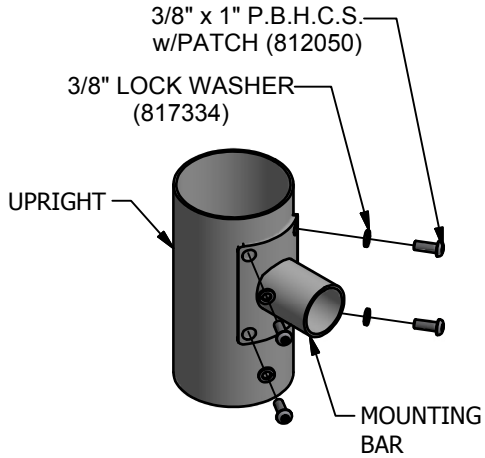
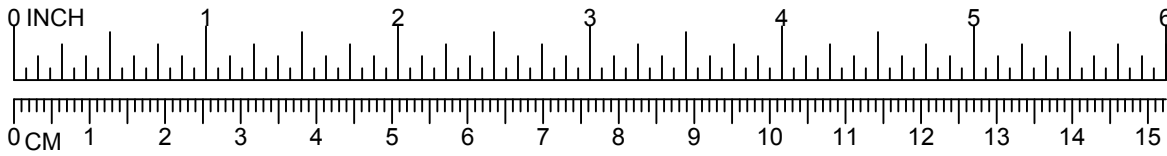

288

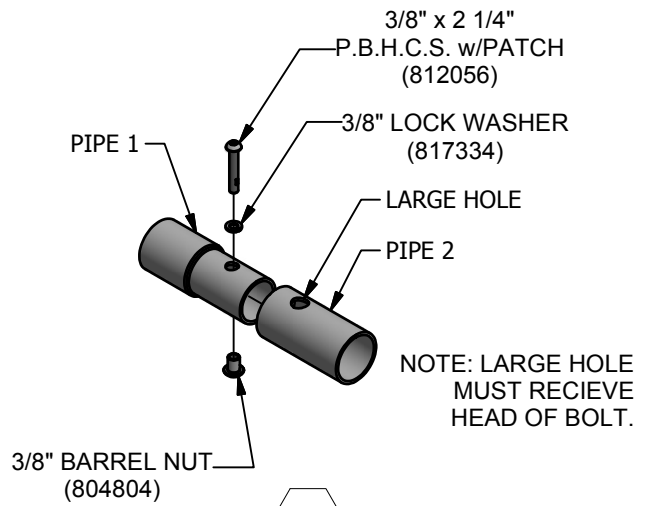

289

DETAILS -for- UP231, UP235

IMPORTANT

TO REDUCE THE RISK OF CLOTHING ENTANGLEMENT IN COMPLIANCE WITH ASTM F1487, ANY BOLT END PROTRUDING MORE THAN TWO FULL THREADS BEYOND THE FACE OF THE NUT SHALL BE CUT-OFF FLUSH, FILED SMOOTH AND TREATED TO PREVENT CORROSION.

NOTE: LOCTITE (SUPPLIED BY OTHERS) SHOULD BE USED ON ALL THREADED HARDWARE.

NOTE: AFTER ASSEMBLY IS COMPLETE, PEEN TEE-NUTS AND FLATWASHERS TO MATCH RADIUS OF PIPE.

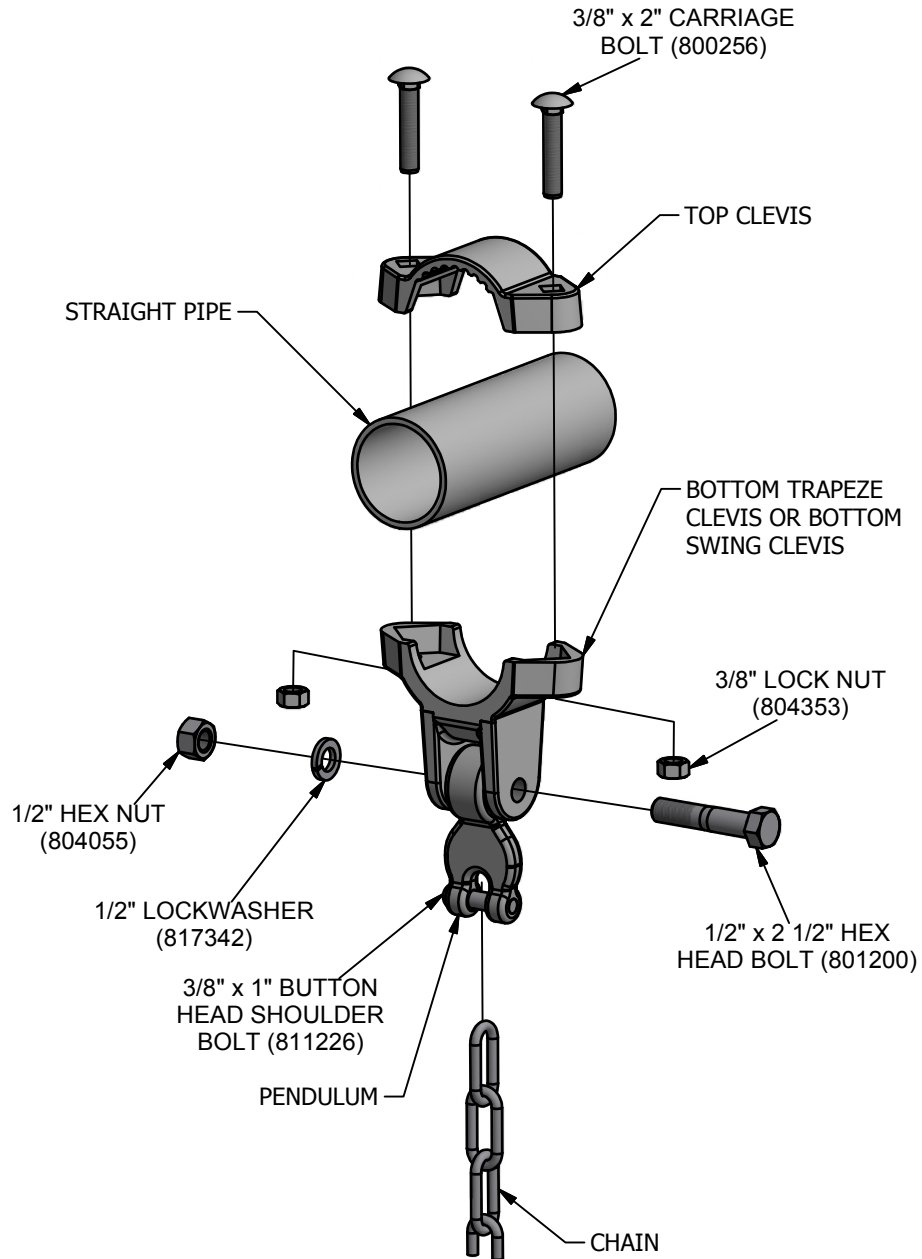
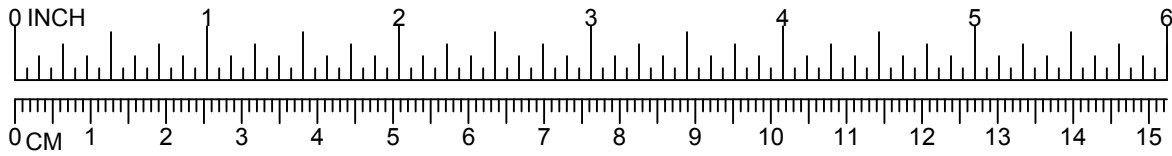

DETAILS -for- UP231, UP235

IMPORTANT

TO REDUCE THE RISK OF CLOTHING ENTANGLEMENT IN COMPLIANCE WITH ASTM F1487, ANY BOLT END PROTRUDING MORE THAN TWO FULL THREADS BEYOND THE FACE OF THE NUT SHALL BE CUT-OFF FLUSH, FILED SMOOTH AND TREATED TO PREVENT CORROSION.

NOTE: LOCTITE (SUPPLIED BY OTHERS) SHOULD BE USED ON ALL THREADED HARDWARE.

NOTE: AFTER ASSEMBLY IS COMPLETE, PEEN TEE-NUTS AND FLATWASHERS TO MATCH RADIUS OF PIPE.

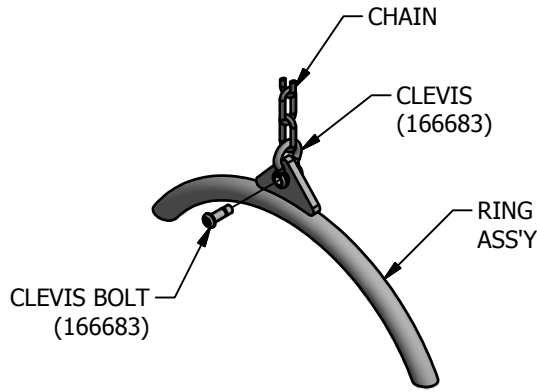
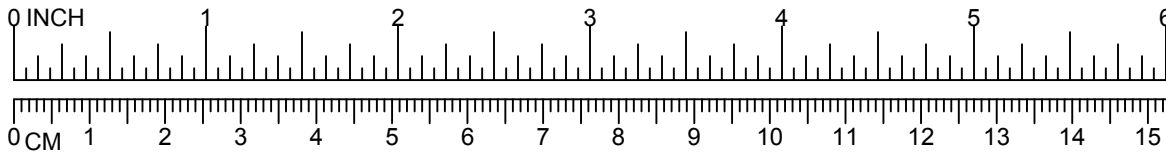

291

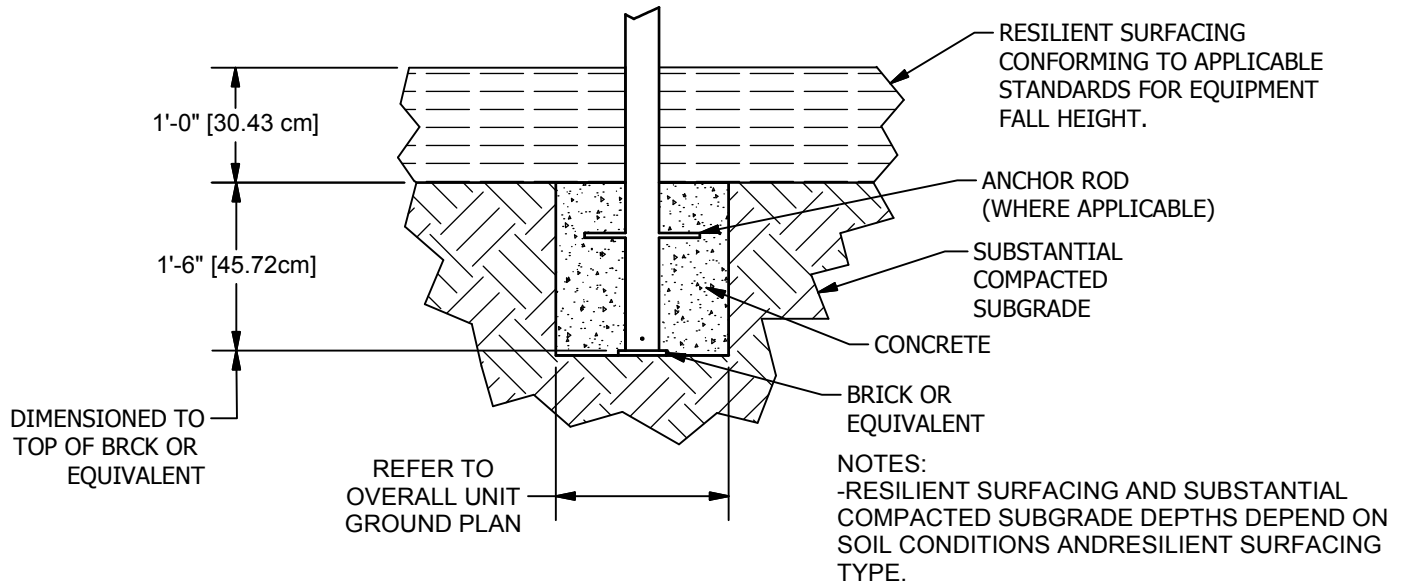

SHOCK ABSORBING PROPERTIES OF SURFACING MATERIALS MAY VARY. IF YOU DETERMINE THAT LESS THAN 1'-0" [30.48cm] OF SURFACING IS REQUIRED, MAKE UP THE DIFFERENCE IN ELEVATION WITH EARTH BEFORE APPLYING SURFACING.

-SLOPED FOOTINGS IS A REQUIREMENT OF EUROPEAN STANDARD EN1176-1 ONLY

-SUGGESTED MINIMUM CONCRETE RATING 3000PSI.

321