



By **ultra site**
A **PLAYCORE** Company

1-800-458-5872

ISSUED/REVISED: 1/23/20

UP221 COMBINATION FITNESS HUB

⬡ = INSTALLATION
DETAIL

○ = PARTS LIST
REFERENCE

INSTALLATION INSTRUCTIONS:

Note: Read installation instructions thoroughly before starting assembly. Bracing material is required during assembly.

Surface Mount: Using Frame Assembly as template, mark hole locations for Wedge Anchors. Refer to Surface Mount Detail.

In-Ground Mount: Prepare ground hole(s) according to In-Ground Mount Detail. Place Uprights in ground holes. Level using sway bracing. Pour concrete according to In-Ground Mount Detail. Allow concrete to cure for a minimum of 7 days.

APPLY USAGE/WARNING LABELS IN APPROXIMATE POSITIONS SHOWN

COMBINATION FITNESS HUB (SURFACE MOUNT) UP221SM COMBINATION FITNESS HUB (IN-GROUND) UP221S

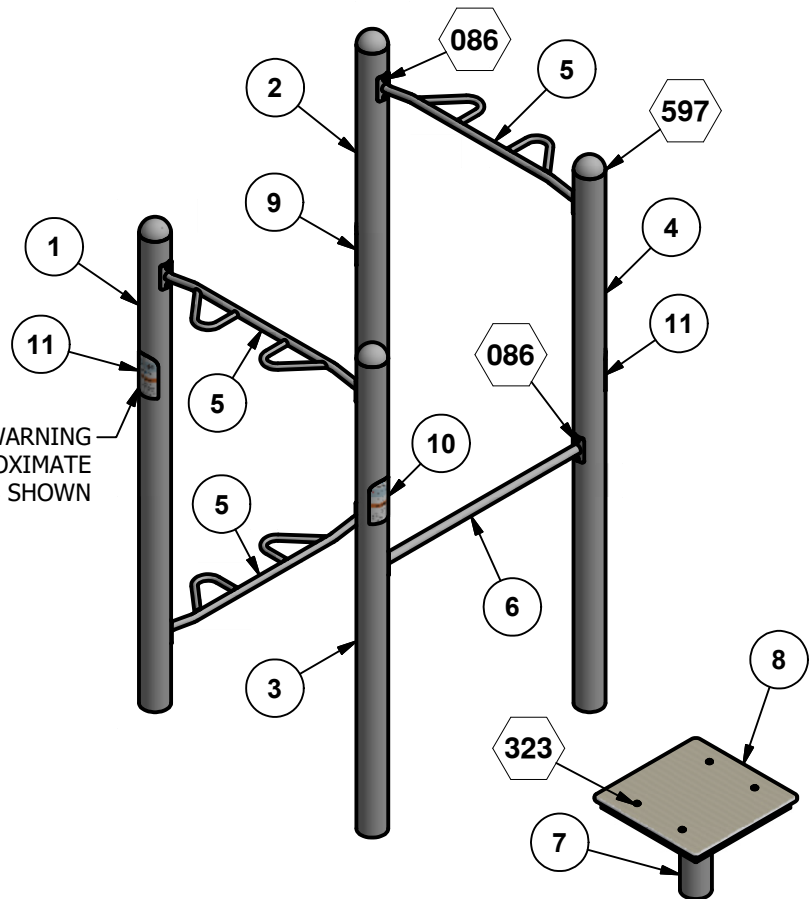

ASSEMBLY DRAWING

NOTE:
CENTER OF UPRIGHTS TO EDGE
OF PLYOMETRIC PLATFORM SHOULD
BE 3'-0" [91.44 cm]

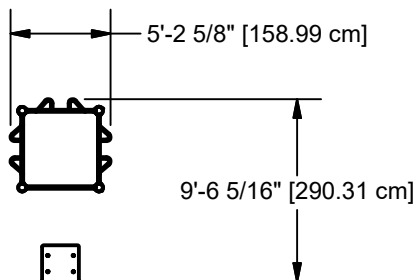

TOP VIEW

Parts List				
REF	DESCRIPTION	UP221S	UP221SM	PART NUMBER
1	UPRIGHT	1	0	LJE5L4
1	UPRIGHT (SURFACE MOUNT)	0	1	216688
2	UPRIGHT	1	0	LJE5L7
2	UPRIGHT (SURFACE MOUNT)	0	1	216689
3	UPRIGHT	1	0	LJE5L5
3	UPRIGHT (SURFACE MOUNT)	0	1	216690
4	UPRIGHT	1	0	LJE5L6
4	UPRIGHT (SURFACE MOUNT)	0	1	216691
5	CHIN UP BAR	3	3	212604
6	RUNG	1	1	212686
7	18" PLYOMETRIC FRAME	1	0	212625
7	18" PLYOMETRIC FRAME (SURFACE MOUNT)	0	1	212627
8	TOP COVER	1	1	403362
	DOME CAP	0	4	212628
	HARDWARE COMPLETE	1	0	218589
	HARDWARE COMPLETE	0	1	218590
	3/8" BARREL NUT	4	4	804804*
	3/8" FLAT WASHER	20	20	817410*
	3/8" LOCK WASHER	20	20	817334*
	3/8" x 3/4" P.B.H.C.S. w/PATCH	4	4	812052*
	1/2" ANCHOR ROD	1	0	135038*
	3/8" x 1" P.B.H.C.S. w/PATCH	16	16	812050*
	3/4" x 4 1/4" WEDGE ANCHOR	0	20	206358*
	3/4" LOCK WASHER	0	20	817354*
	3/16" x 13/32" RIVET	0	8	805366*
9	USAGE/WARNING LABEL	1	1	218583*
10	USAGE/WARNING LABEL	1	1	218584*
11	USAGE/WARNING LABEL	2	2	218585*

Unless Otherwise Specified, All Units of Measure are Each
* Included in Hardware

Warning: During Installation, Hardware And Small Parts Are Choking Hazards For Young Children. Store Unused Parts Appropriately Until Assembly Is Completed. Once Assembly Is Completed, Remove Any Unused Parts From The Play Environment And Dispose/Save Them In A Secure Location.

Note: Peen Tee-Nuts and Flatwashers to match radius of pipe after assembly is complete.

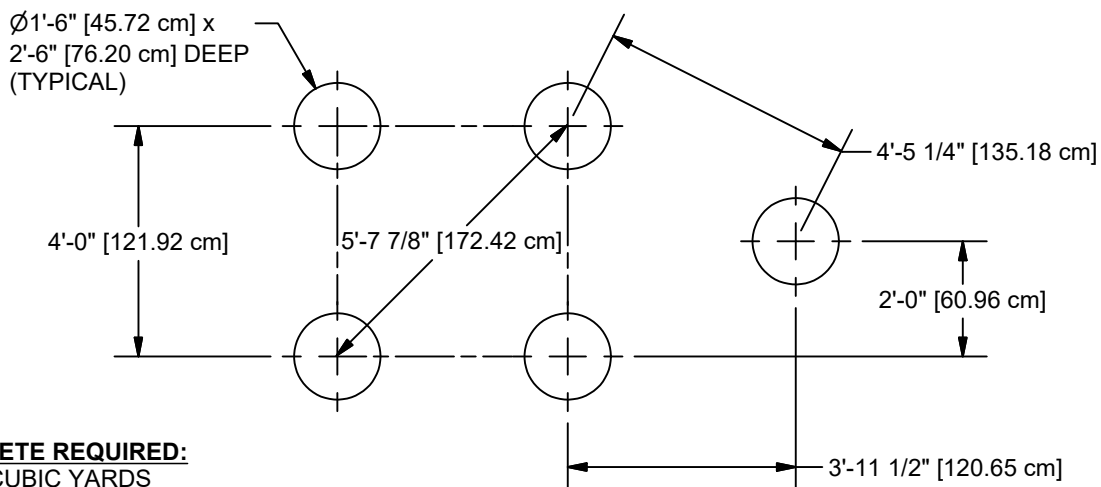

CONCRETE REQUIRED:
.49 CUBIC YARDS
[.38 CUBIC METERS]

GROUND PLAN

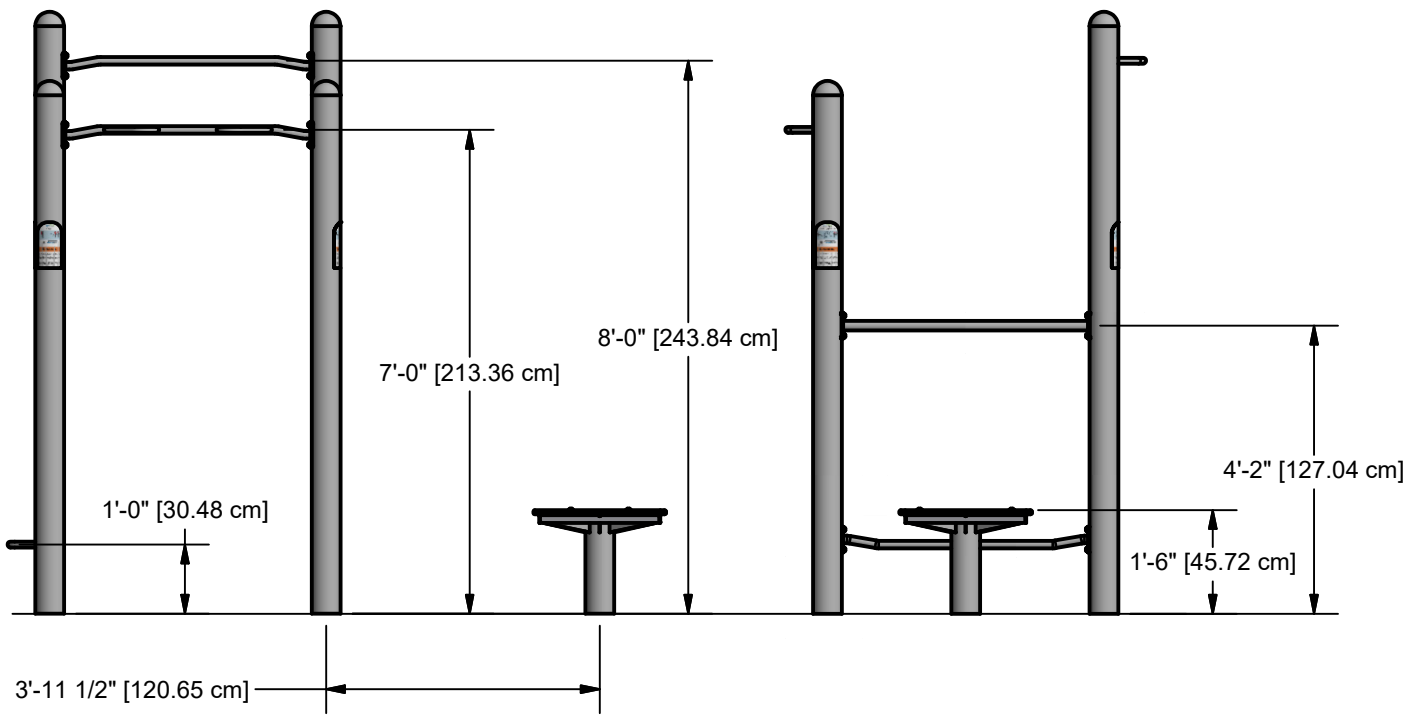

FRONT & SIDE ELEVATION VIEWS

SPECIFICATIONS

NOTE: THIS INSTALLATION BOOKET SHOULD BE KEPT IN CUSTOMER'S FILE FOR FUTURE REFERENCE.

NOTE: Read installation instructions thoroughly before starting assembly. Pour concrete only after final assembly is complete. Bracing material may be required during assembly.

NOTE: Do not overtighten bolts. To overtighten may cause buckling or dimpling of some parts.

NOTE: Do not tighten any nuts, bolts, rods, etc. until the unit is completely assembled.

UPRIGHTS: Shall be fabricated from 5" O.D. x .120" (11 Gauge) wall galvanized steel tubing. Uprights shall be coated after fabrication with a custom formula of TGIC polyester powder coating in conformance with the specifications outlined herein.

UPRIGHTS (SURFACE MOUNT): Shall be fabricated from 5" O.D. x .120" (11 Gauge) wall galvanized steel tubing and 1/2" Thick H.R. Steel. Uprights shall be an all weld assembly and shall be coated after fabrication with a custom formula of TGIC polyester powder coating in conformance with the specifications outlined herein.

CHIN UP BAR: Shall be fabricated from 1-5/16" O.D. x .109" (12 Gauge) wall galvanized steel tubing, 1-1/16" O.D. x .072" (15 Gauge) wall galvanized steel tubing, and 1/4" Thick H.R. Steel. Chin Up Bar shall be an all weld assembly and shall be coated after fabrication with a custom formula of TGIC polyester powder coating in conformance with the specifications outlined herein.

RUNG: Shall be fabricated from 1-5/8" O.D. x .109" (12 gauge) wall galvanized steel tubing and 1/4" Thick H.R. Steel. Rung shall be an all weld assembly and shall be coated after fabrication with a custom formula of TGIC polyester powder coating in conformance with the specifications outlined herein.

18" PLYOMETRIC FRAME: Shall be fabricated from 5" O.D. x .120" (11 Gauge) wall galvanized steel tubing and 12 Gauge Thick H.R. Steel. 18" Plyometric Frame shall be an all weld assembly and shall be coated after fabrication with a custom formula of TGIC polyester powder coating in conformance with the specifications outlined herein.

18" PLYOMETRIC FRAME (SURFACE MOUNT): Shall be fabricated from 5" O.D. x .120" (11 Gauge) wall galvanized steel tubing, 12 Gauge Thick H.R. Steel, and 1/2" Thick H.R. Steel. 18" Plyometric Frame shall be an all weld assembly and shall be coated after fabrication with a custom formula of TGIC polyester powder coating in conformance with the specifications outlined herein.

TOP COVER: Shall be made from 3/4" Thick (solid) high density, UV-stabilized and color impregnated polyethylene.

POWDER COAT FINISH: Shall be an electrostatically applied custom formula of TGIC polyester powder. All components will be free of sharp edges and excess weld spatter and shall be cleaned in a four stage solvent / zirconium based bath system (free of iron phosphate), as a rust inhibitor, and a zirconium conversion coating to prevent flash rusting before coating. In addition, all welds shall be protectively coated with ZRP, a zinc rich primer that forms a rust-resistant barrier layer over each weld prior to application of the powder coating. The powder coating shall have a super tough finish with maximum exterior durability and will have superior adhesion characteristics. Typical characteristics are: Two coat process to achieve 3.0 - 5.0 mil thickness and oven cured between 350 degrees Fahrenheit. Pencil Hardness H (ASTM D-3363), Impact (ASTM D-2794- 69), Wedge Bend (ASTM D-522-68), Adhesion (Cross Hatch ASTM D-3359 & Knife Scratch ASTM D-2197), Environmental (Stain Resistance ASTM D-1308, Humidity ASTM D-2247 - 87, Salt Spray ASTM B-117 & Fadometer 300 hrs with no loss of gloss), Over-bake Stability 100% at 350 degrees Fahrenheit for 10 minutes.

HARDWARE: All nuts, bolts, screws, inserts, and lockwashers used in the assembly of all play equipment, shall be stainless steel, yellow dichromate plated steel, blue-coat plated steel, mechanically galvanized or powder coated/yellow dichromate plated steel. All primary fasteners shall be 300 series stainless steel. Fasteners with yellow dichromate treatment have an electro deposited, 99.9% pure zinc substrate applied from a specially formulated solution sealed with a yellow dichromate top coat designed to work in conjunction with the zinc plating Yellow dichromate has a 320% longer life to white corrosion and 275% longer to red corrosion than does hot-dip galvanizing.

SPECIFICATIONS: ULTRASITE has a policy of continuous improvement and reserves the right to discontinue or change specifications without notice.



IMPORTANT PRODUCT INFORMATION AND SAFETY WARNINGS



- Installation over a hard surface such as concrete, asphalt, or packed earth may result in serious injury or death from fails. Especially all elevated upper-body strength building equipment.
- ALWAYS FOLLOW INSTALLATION INSTRUCTIONS WHEN ERECTING EQUIPMENT.
- Worn surfaces around equipment should be restored. Concrete footings should never be exposed. Surface depth should comply with installation instructions.
- Equipment should be placed to eliminate conflicting traffic patterns.
- All equipment should be free of rust and repainted whenever necessary to deter rusting.
- All protruding nuts and bolts should be covered; sharp edges on pipes should be capped or removed. Check for bent, broken or severely worn pipe and replace.
- Test overall stability and rigidity of all exercise equipment. Check for proper assembly, installation and ground anchoring.
- Check for and repair damage caused by wear or vandalism, a major factor in injury-causing situations.
- UltraSite® PROVIDES ITS CUSTOMERS WITH COMPLETE SPECIFICATION SHEETS AND INSTALLATION INSTRUCTIONS. THE SPECIFICATION SHEET CONTAINS THE LISTING OF EVERY PART USED IN A PIECE OF EQUIPMENT AND SHOULD BE KEPT IN THE CUSTOMER'S FILES FOR ACCURATE REFERENCE WHEN REPLACEMENT PARTS ARE NEEDED.
- Never add components not intended for use with this product.
- Regular checking of all parts, castings, etc. should be made. If a part is broken or worn it should be replaced immediately.
- Proper maintenance of UltraSite® equipment requires regular tightening of all bolts, nuts, and set screws.
- Check to be sure all fittings are tight and that the bars and pipes do not move.

DETAILS -for- UP221S, UP221SM

IMPORTANT

TO REDUCE THE RISK OF CLOTHING ENTANGLEMENT IN COMPLIANCE WITH ASTM F1487, ANY BOLT END PROTRUDING MORE THAN TWO FULL THREADS BEYOND THE FACE OF THE NUT SHALL BE CUT-OFF FLUSH, FILED SMOOTH AND TREATED TO PREVENT CORROSION.

NOTE: LOCTITE (SUPPLIED BY OTHERS) SHOULD BE USED ON ALL THREADED HARDWARE.

NOTE: AFTER ASSEMBLY IS COMPLETE, PEEN TEE-NUTS AND FLATWASHERS TO MATCH RADIUS OF PIPE.

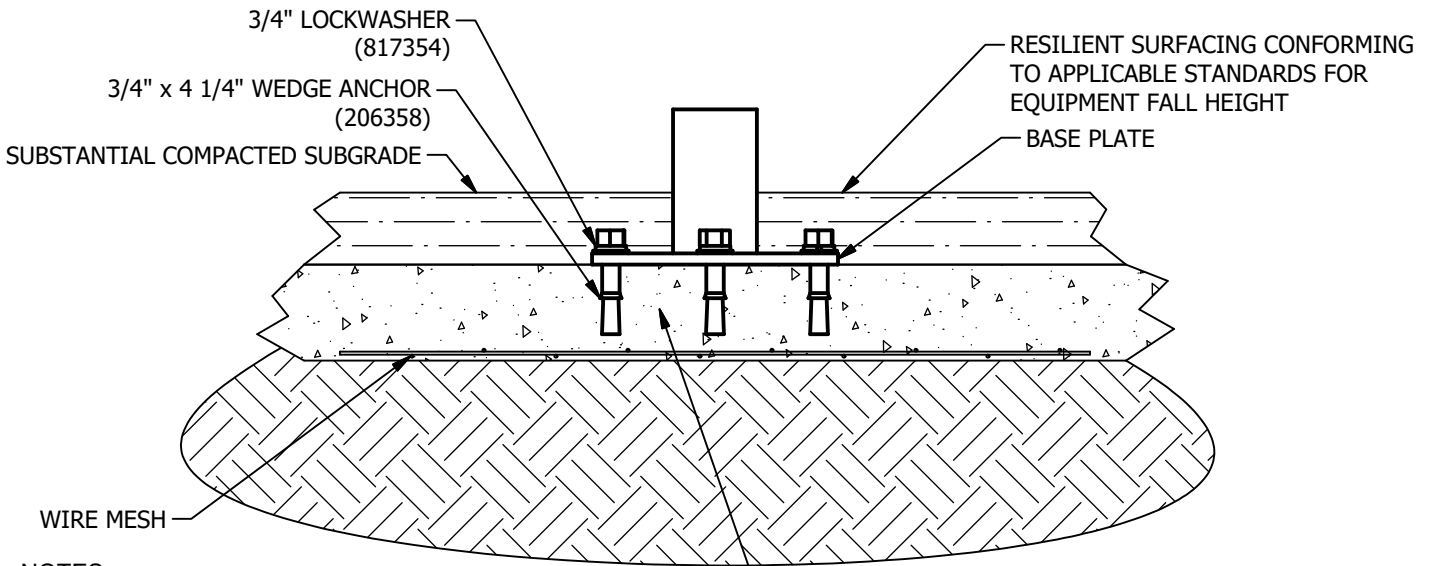
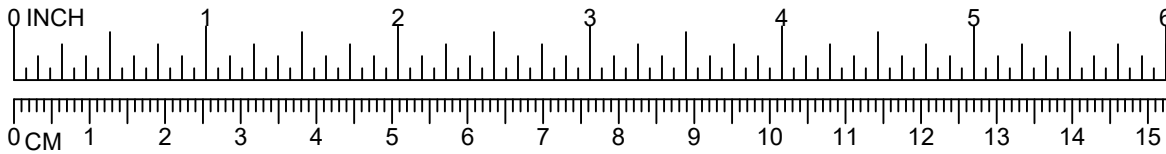

NOTES:

-LOOSE FILL SURFACING NOT RECOMMENDED FOR SURFACE MOUNT.

-RESILIENT SURFACING AND SUBSTANTIAL COMPACTED SUBGRADE DEPTHS DEPEND ON SOIL CONDITIONS AND RESILIENT SURFACING TYPE.

EXISTING CONCRETE MUST BE MINIMUM 3,000 PSI, 4\"/>

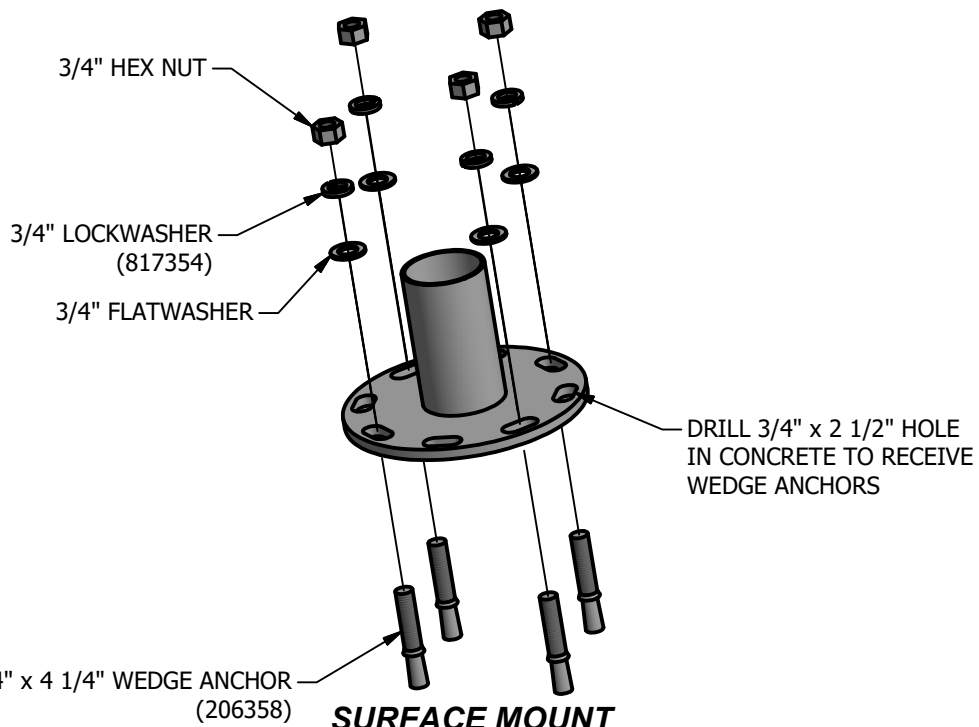

SURFACE MOUNT

DETAILS -for- UP221S, UP221SM

IMPORTANT

TO REDUCE THE RISK OF CLOTHING ENTANGLEMENT IN COMPLIANCE WITH ASTM F1487, ANY BOLT END PROTRUDING MORE THAN TWO FULL THREADS BEYOND THE FACE OF THE NUT SHALL BE CUT-OFF FLUSH, FILED SMOOTH AND TREATED TO PREVENT CORROSION.

NOTE: LOCTITE (SUPPLIED BY OTHERS) SHOULD BE USED ON ALL THREADED HARDWARE.

NOTE: AFTER ASSEMBLY IS COMPLETE, PEEN TEE-NUTS AND FLATWASHERS TO MATCH RADIUS OF PIPE.

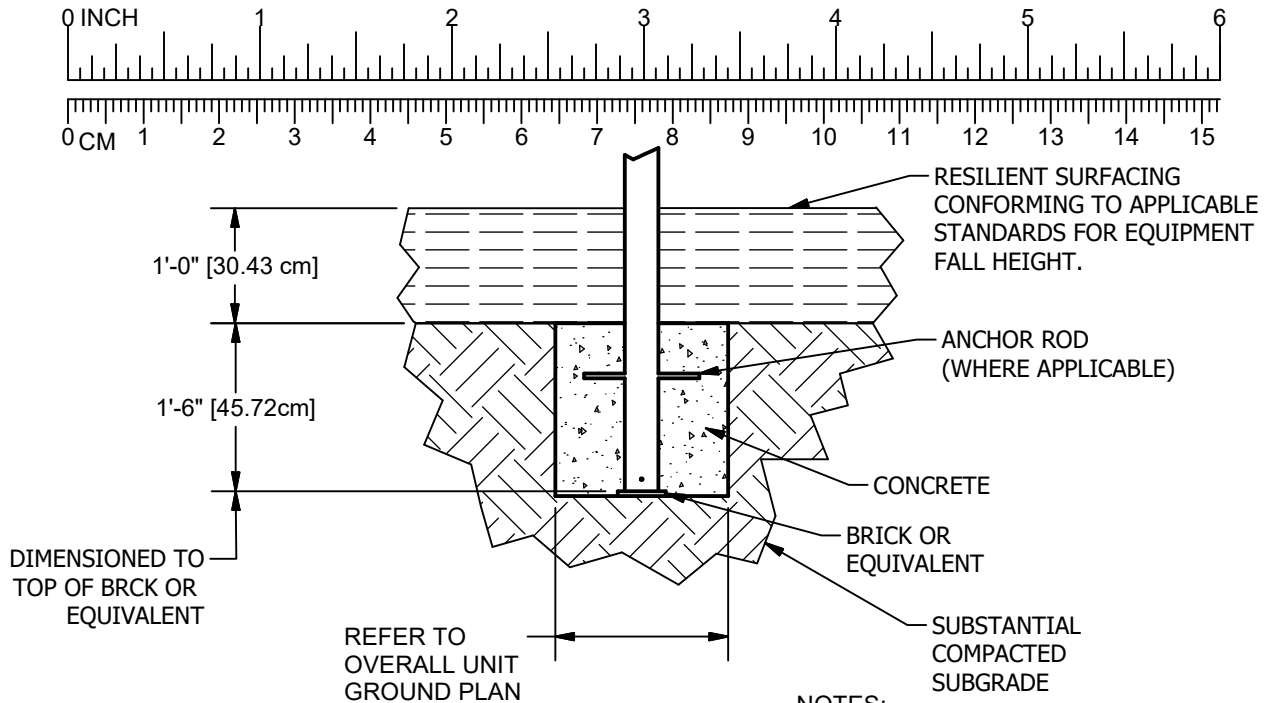

SHOCK ABSORBING PROPERTIES OF SURFACING MATERIALS MAY VARY. IF YOU DETERMINE THAT LESS THAN 1'-0" [30.48cm] OF SURFACING IS REQUIRED, MAKE UP THE DIFFERENCE IN ELEVATION WITH EARTH BEFORE APPLYING SURFACING.

NOTES:

-RESILIENT SURFACING AND SUBSTANTIAL COMPACTED SUBGRADE DEPTHS DEPEND ON SOIL CONDITIONS AND RESILIENT SURFACING TYPE.

-SLOPED FOOTINGS IS A REQUIREMENT OF EUROPEAN STANDARD EN1176-1 ONLY

-SUGGESTED MINIMUM CONCRETE RATING 3000PSI.

IN-GROUND MOUNT

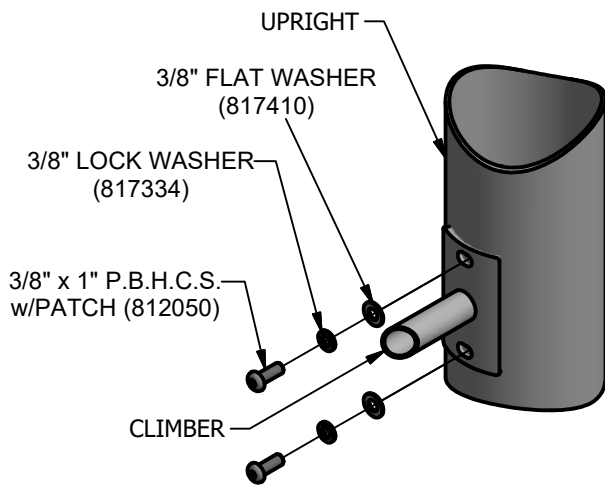

086

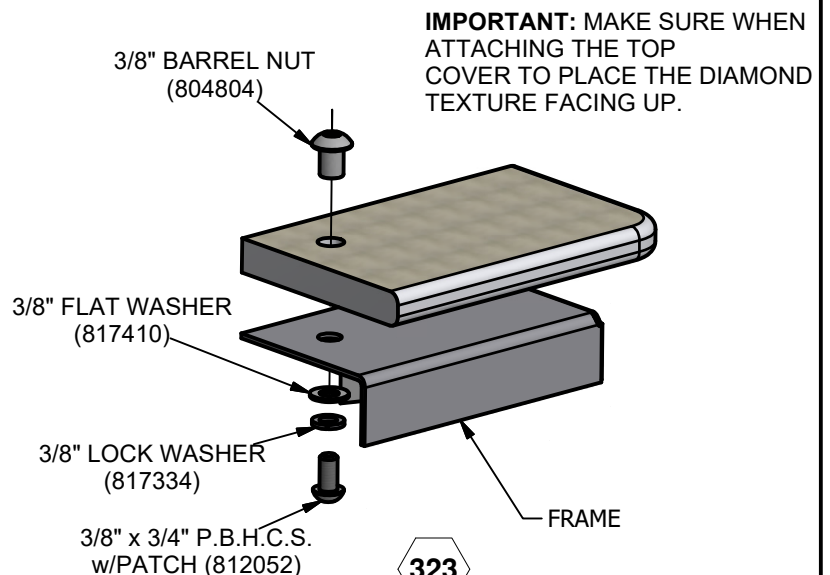

323

DETAILS -for- UP221S, UP221SM

IMPORTANT

TO REDUCE THE RISK OF CLOTHING ENTANGLEMENT IN COMPLIANCE WITH ASTM F1487, ANY BOLT END PROTRUDING MORE THAN TWO FULL THREADS BEYOND THE FACE OF THE NUT SHALL BE CUT-OFF FLUSH, FILED SMOOTH AND TREATED TO PREVENT CORROSION.

NOTE: LOCTITE (SUPPLIED BY OTHERS) SHOULD BE USED ON ALL THREADED HARDWARE.

NOTE: AFTER ASSEMBLY IS COMPLETE, PEEN TEE-NUTS AND FLATWASHERS TO MATCH RADIUS OF PIPE.

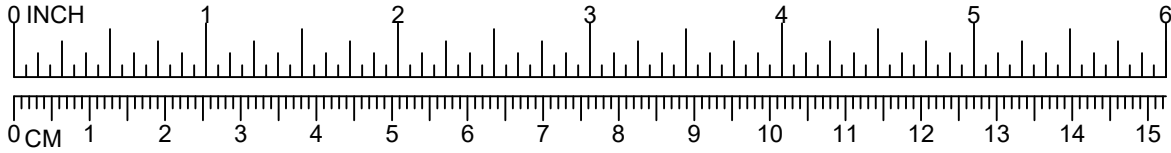

3/16" x 13/32" DRIVE
RIVET (805366)

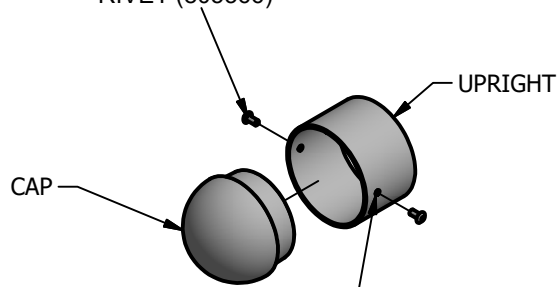

USING EXISTING HOLES IN
PIPE AS TEMPLATE, DRILL Ø3/16"
HOLES IN CAP AND INSTALL USING
DRIVE RIVETS.

597